

Description

The 5P49V6965 is a programmable clock generator intended for high-performance consumer, networking, industrial, computing, and data-communications applications. Configurations may be stored in on-chip One-Time Programmable (OTP) memory or changed using I²C interface. This is Renesas' sixth generation of programmable clock technology (VersaClock 6E).

The frequencies are generated from a single reference clock. The reference clock can come from one of the two redundant clock inputs. A glitchless manual switchover function allows one of the redundant clocks to be selected during normal operation.

Two select pins allow up to four different configurations to be programmed and accessible using processor GPIOs or bootstrapping. The different selections may be used for different operating modes (full function, partial function, partial power-down), regional standards (US, Japan, Europe) or system production margin testing. The device may be configured to use one of two I²C addresses to allow multiple devices to be used in a system.

Typical Applications

- Ethernet switch/router
- PCI Express 1.0 / 2.0 / 3.0 / 4.0 Spread Spectrum on
- PCI Express 1.0 / 2.0 / 3.0 / 4.0 / 5.0 Spread Spectrum off
- Broadcast video/audio timing
- Multi-function printer
- Processor and FPGA clocking
- Any-frequency clock conversion
- MSAN/DSLAM/PON
- Fiber Channel, SAN
- Telecom line cards
- Laser distance sensing

Block Diagram

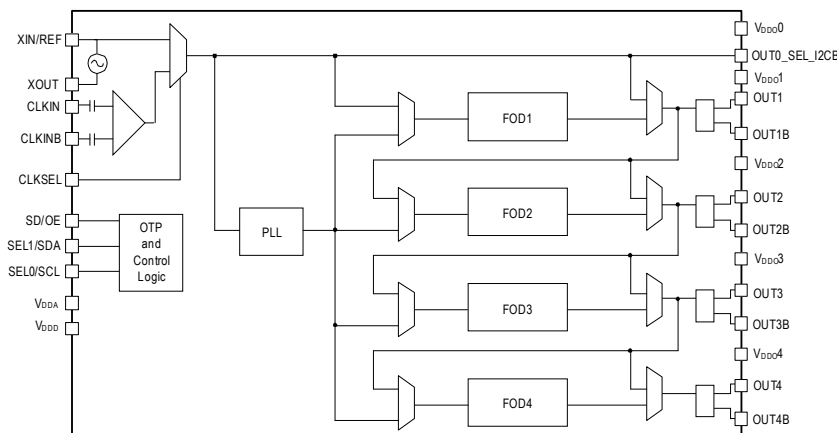

Features

- Flexible 1.8V, 2.5V, 3.3V power-rails
- High-performance, low phase noise PLL, < 0.5ps RMS typical phase jitter on outputs
- Four banks of internal OTP memory
 - In-system or factory programmable
 - 2 select pins accessible with processor GPIOs or bootstrapping
- I²C serial programming interface
 - 0xD0 or 0xD4 I2C address options allows multiple devices configured in a same system
- Reference LVCMOS output clock
- Four universal output pairs individually configurable:
 - Differential (LVPECL, LVDS or HCSL)
 - 2 single-ended (2 LVCMOS in-phase or 180 degrees out of phase)
 - I/O V_{DD}s can be mixed and matched, supporting 1.8V (LVDS and LVCMOS), 2.5V, or 3.3V
- Output frequency ranges:
 - LVCMOS clock outputs: 1kHz to 200MHz
 - LVDS, LVPECL, HCSL differential clock outputs: 1kHz to 350MHz
- Redundant clock inputs with manual switchover
- Programmable output enable or power-down mode
- Available in 4 × 4 mm 24-VFQFPN package
- -40° to +85°C industrial temperature operation

Contents

Description	1
Typical Applications	1
Features	1
Block Diagram	1
Pin Assignments	3
Pin Descriptions	3
Absolute Maximum Ratings	5
Thermal Characteristics	5
Recommended Operating Conditions	5
Electrical Characteristics	6
I2C Bus Characteristics	11
Test Loads	12
Jitter Performance Characteristics	13
PCI Express Jitter Performance and Specification	14
Features and Functional Blocks	16
Device Startup and Power-On-Reset	16
Reference Clock and Selection	16
Manual Switchover	16
Internal Crystal Oscillator (XIN/REF)	17
Programmable Loop Filter	18
Fractional Output Dividers (FOD)	18
Output Drivers	18
SD/OE Pin Function	19
I2C Operation	19
Typical Application Circuits	20
Input – Driving the XIN/REF or CLKIN	21
Output – Single-ended or Differential Clock Terminations	23
Package Outline Drawings	26
Marking Diagram	26
Ordering Information	26
Revision History	27

Pin Assignments

Figure 1. Pin Assignments for 4 x 4 mm 24-VFQFPN Package – Top View

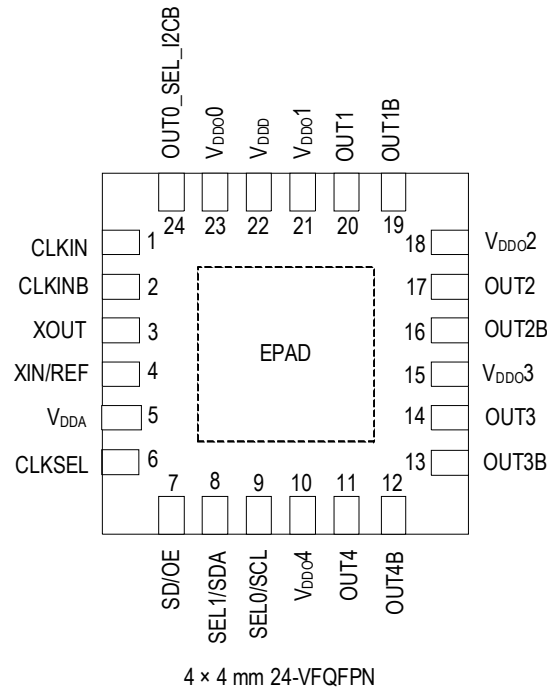

Pin Descriptions

Table 1. Pin Descriptions

Number	Name	Type		Description
1	CLKIN	Input	Internal Pull-down	Differential clock input. Weak 100kΩ internal pull-down.
2	CLKINB	Input	Internal Pull-down	Complementary differential clock input. Weak 100kΩ internal pull-down.
3	XOUT	Output		Crystal oscillator interface output.
4	XIN/REF	Input		Crystal oscillator interface input, or single-ended LVCMOS clock input. Input voltage needs to be below 1.2V. Refer to the section Driving XIN/REF with a CMOS Driver .
5	V _{DDA}	Power		Analog functions power supply pin. Connect to 1.8V to 3.3V. V _{DDA} and V _{DD0} should have the same voltage applied.
6	CLKSEL	Input	Internal Pull-down	Input clock select. Selects the active input reference source in manual switchover mode. 0 = XIN/REF, XOUT (default). 1 = CLKIN, CLKINB. See Table 20. Input Clock Select for more details.
7	SD/OE	Input	Internal Pull-down	Enables/disables the outputs (OE) or powers down the chip (SD).
8	SEL1/SDA	Input	Internal Pull-down	Configuration select pin, or I ² C SDA input as selected by OUT0_SEL_I2CB. Weak internal pull-down resistor.
9	SEL0/SCL	Input	Internal Pull-down	Configuration select pin, or I ² C SCL input as selected by OUT0_SEL_I2CB. Weak internal pull-down resistor.

Table 1. Pin Descriptions (Cont.)

Number	Name	Type		Description
10	V _{DDO4}	Power		Output power supply. Connect to 1.8 to 3.3V. Sets output voltage levels for OUT4/OUT4B.
11	OUT4	Output		Output clock 4. Refer to the Output Drivers section for more details.
12	OUT4B	Output		Complementary output clock 4. Refer to the Output Drivers section for more details.
13	OUT3B	Output		Complementary output clock 3. Refer to the Output Drivers section for more details.
14	OUT3	Output		Output clock 3. Refer to the Output Drivers section for more details.
15	V _{DDO3}	Power		Output power supply. Connect to 1.8 to 3.3V. Sets output voltage levels for OUT3/OUT3B.
16	OUT2B	Output		Complementary output clock 2. Refer to the Output Drivers section for more details.
17	OUT2	Output		Output clock 2. Refer to the Output Drivers section for more details.
18	V _{DDO2}	Power		Output power supply. Connect to 1.8 to 3.3V. Sets output voltage levels for OUT2/OUT2B.
19	OUT1B	Output		Complementary output clock 1. Refer to the Output Drivers section for more details.
20	OUT1	Output		Output clock 1. Refer to the Output Drivers section for more details.
21	V _{DDO1}	Power		Output power supply. Connect to 1.8 to 3.3V. Sets output voltage levels for OUT1/OUT1B.
22	V _{DDD}	Power		Digital functions power supply pin. Connect to 1.8 to 3.3V. V _{DDA} and V _{DDD} should have the same voltage applied.
23	V _{DDO0}	Power		Power supply pin for OUT0_SEL_I2CB. Connect to 1.8 to 3.3V. Sets output voltage levels for OUT0.
24	OUT0_SEL_I2CB	Input/ Output	Internal Pull-down	Latched input/LVCMOS output. At power-up, the voltage at the pin OUT0_SEL_I2CB is latched by the part and used to select the state of pins 8 and 9. If a weak pull-up (10kΩ) is placed on OUT0_SEL_I2CB, pins 8 and 9 will be configured as hardware select pins, SEL1 and SEL0. If a weak pull-down (10kΩ) is placed on OUT0_SEL_I2CB or it is left floating, pins 8 and 9 will act as the SDA and SCL pins of an I ² C interface. After power-up, the pin acts as an LVCMOS reference output.
25	GND	GND		Connect to ground pad.

Absolute Maximum Ratings

The absolute maximum ratings are stress ratings only. Stresses greater than those listed below can cause permanent damage to the device. Functional operation of the device at absolute maximum ratings is not implied. Exposure to absolute maximum rating conditions may affect device reliability.

Table 2. Absolute Maximum Ratings

Item	Rating
Supply Voltage, V_{DDA} , V_{DDD} , V_{DDO}	3.6V.
XIN/REF Input	1.2V.
CLKIN, CLKINB Input	V_{DDO0} , 1.2V voltage swing.
I ² C Loading Current	10mA.
Storage Temperature, T_{STG}	-65°C to 150°C.
Junction Temperature	125°C
ESD Human Body Model	2000V.

Thermal Characteristics

Table 3. Thermal Characteristics

Symbol	Parameter	Value	Unit
θ_{JA}	Theta J_A . Junction to air thermal impedance (0mps).	42	°C/W
θ_{JB}	Theta J_B . Junction to board thermal impedance (0mps).	2.35	°C/W
θ_{JC}	Theta J_C . Junction to case thermal impedance (0mps).	41.8	°C/W

Recommended Operating Conditions

Table 4. Recommended Operating Conditions

Symbol	Parameter	Minimum	Typical	Maximum	Unit
V_{DDOX}	Power supply voltage for supporting 1.8V outputs.	1.71	1.8	1.89	V
	Power supply voltage for supporting 2.5V outputs.	2.375	2.5	2.625	V
	Power supply voltage for supporting 3.3V outputs.	3.135	3.3	3.465	V
V_{DDD}	Power supply voltage for core logic functions.	1.71	-	3.465	V
V_{DDA}	Analog power supply voltage. Use filtered analog power supply.	1.71	-	3.465	V
T_{PU}	Power ramp time for all V_{DDs} to reach 90% of V_{DD} .	0.05	-	50	ms
T_A	Operating temperature, ambient.	-40	-	85	°C
C_L	Maximum load capacitance (3.3V LVCMOS only).	-	-	15	pF

Electrical Characteristics

Table 5. Current Consumption

$V_{DDA}, V_{DDD}, V_{DDO0} = 3.3V \pm 5\%, 2.5V \pm 5\%, 1.8V \pm 5\%$, $T_A = -40^\circ C$ to $+85^\circ C$.

Symbol	Parameter	Conditions	Minimum	Typical	Maximum	Unit
I_{DDCORE}^1	Core Supply Current	100MHz on all outputs, 25MHz REFCLK.	-	33	42	mA
I_{DDOx}	Output Buffer Supply Current	LVPECL, 350MHz, 3.3V V_{DDOx}^2 .	-	45	58	mA
		LVPECL, 350MHz, 2.5V V_{DDOx}^2 .	-	36	47	mA
		LVDS, 350MHz, 3.3V V_{DDOx}^2 .	-	26	32	mA
		LVDS, 350MHz, 2.5V V_{DDOx}^2 .	-	25	30	mA
		LVDS, 350MHz, 1.8V V_{DDOx}^2 .	-	22	27	mA
		HCSL, 250MHz, 3.3V V_{DDOx}^2 .	-	39	48	mA
		HCSL, 250MHz, 2.5V V_{DDOx}^2 .	-	37	46	mA
		LVC MOS, 50MHz, 3.3V, $V_{DDOx}^{2,3}$.	-	22	27	mA
		LVC MOS, 50MHz, 2.5V, $V_{DDOx}^{2,3}$.	-	20	24	mA
		LVC MOS, 50MHz, 1.8V, $V_{DDOx}^{2,3}$.	-	17	21	mA
		LVC MOS, 200MHz, 3.3V $V_{DDOx}^{2,3}$.	-	43	56	mA
		LVC MOS, 200MHz, 2.5V $V_{DDOx}^{2,3}$.	-	33	43	mA
		LVC MOS, 200MHz, 1.8V $V_{DDOx}^{2,3}$.	-	24	31	mA
I_{DDPD}	Power Down Current	SD asserted, I ² C programming.	-	10	12	mA

¹ $I_{DDCORE} = I_{DDA} + I_{DDD}$.

² Measured into a 5" 50Ω trace. See Test Loads section for more details.

³ Single CMOS driver active.

Table 6. AC Timing Characteristics

V_{DDA} , V_{DDD} , V_{DDO0} = 3.3V \pm 5%, 2.5V \pm 5%, 1.8V \pm 5%, T_A = -40°C to +85°C unless stated otherwise.

Symbol	Parameter	Conditions	Minimum	Typical	Maximum	Unit
F_{IN}^1	Input Frequency	Input frequency limit (crystal).	8	-	40	MHz
		Input frequency limit (CLKIN,CLKINB).	1	-	350	MHz
		Input frequency limit (single-ended over XIN).	1	-	200	MHz
F_{OUT}^2	Output Frequency	Single-ended clock output limit (LVCMOS), individual FOD mode.	1	-	200	MHz
		Differential clock output limit (LVPECL/LVDS/HCSL), individual FOD mode.	1	-	350	
		Single-ended clock output limit (LVCMOS), cascaded FOD mode, output 2–4.	0.001	-	200	
		Differential clock output limit (LVPECL/LVDS/HCSL), cascaded FOD mode, output 2–4.	0.001	-	350	
f_{VCO}	VCO Operating Frequency Range		2500	-	2900	MHz
T_{DC}^3	Output Duty Cycle	Measured at $V_{DD}/2$, all outputs except reference output, V_{DDOX} = 2.5V or 3.3V.	45	50	55	%
		Measured at $V_{DD}/2$, all outputs except reference output, V_{DDOX} = 1.8V	40	50	60	%
		Measured at $V_{DD}/2$, reference output OUT0 (5MHz–150.1MHz) with 50% duty cycle input.	40	50	60	%
		Measured at $V_{DD}/2$, reference output OUT0 (150.1MHz–200MHz) with 50% duty cycle input.	30	50	70	%
T_{SKEW}	Output Skew	Skew between the same frequencies, with outputs using the same driver format and phase delay set to 0ns.	-	75	-	ps
$T_{STARTUP}^{4,5}$	Startup Time	Measured after all V_{DD} s have risen above 90% of their target value ⁶ .	-	-	30	ms
		PLL lock time from shutdown mode.	-	3	4	ms

¹ Practical lower frequency is determined by loop filter settings.

² A slew rate of 2.75V/ns or greater should be selected for output frequencies of 100MHz or higher.

³ Duty cycle is only guaranteed at maximum slew rate settings.

⁴ Actual PLL lock time depends on the loop configuration.

⁵ Includes loading the configuration bits from EPROM to PLL registers. It does not include EPROM programming/write time.

⁶ Power-up with temperature calibration enabled; contact Renesas if shorter lock-time is required in system.

Table 7. General Input Characteristics

$V_{DDA}, V_{DDD}, V_{DDO0} = 3.3V \pm 5\%, 2.5V \pm 5\%, 1.8V \pm 5\%$, $T_A = -40^\circ C$ to $+85^\circ C$ unless stated otherwise.

Symbol	Parameter	Conditions	Minimum	Typical	Maximum	Unit
C_{IN}	Input Capacitance	CLKIN,CLKINB,CLKSEL,SD/OE,SEL1/SD A, SEL0/SCL.	-	3	7	pF
R_{PD}	Pull-down Resistor	CLKSEL, SD/OE, SEL1/SDA, SEL0/SCL, CLKIN, CLKINB, OUT0_SEL_I2CB.	100	-	300	kΩ
V_{IH}	Input High Voltage	CLKSEL, SD/OE.	$0.7 \times V_{DDD}$	-	$V_{DDD} + 0.3$	V
V_{IL}	Input Low Voltage	CLKSEL, SD/OE.	GND - 0.3	-	$0.3 \times V_{DDD}$	V
V_{IH}	Input High Voltage	OUT0_SEL_I2CB.	1.7	-	$V_{DDO0} + 0.3$	V
V_{IL}	Input Low Voltage	OUT0_SEL_I2CB.	GND - 0.3	-	0.4	V
V_{IH}	Input High Voltage	XIN/REF.	0.8	-	1.2	V
V_{IL}	Input Low Voltage	XIN/REF.	GND - 0.3	-	0.4	V
T_R/T_F	Input Rise/Fall Time	CLKSEL, SD/OE, SEL1/SDA, SEL0/SCL.	-	-	300	ns

Table 8. CLKIN Electrical Characteristics

$V_{DDA}, V_{DDD}, V_{DDO0} = 3.3V \pm 5\%, 2.5V \pm 5\%, 1.8V \pm 5\%$, $T_A = -40^\circ C$ to $+85^\circ C$ unless stated otherwise.

Symbol	Parameter	Conditions	Minimum	Typical	Maximum	Unit
V_{SWING}	Input Amplitude – CLKIN, CLKINB	Peak to peak value, single-ended.	200	-	1200	mV
dv/dt	Input Slew Rate – CLKIN, CLKINB	Measured differentially.	0.4	-	8	V/ns
I_{IL}	Input Leakage Low Current	$V_{IN} = GND$.	-5	-	5	μA
I_{IH}	Input Leakage High Current	$V_{IN} = 1.7V$.	-	-	20	μA
DC_{IN}	Input Duty Cycle	Measurement from differential waveform.	45	-	55	%

Table 9. Electrical Characteristics – CMOS Outputs

$V_{DDA}, V_{DDD}, V_{DDO0} = 3.3V \pm 5\%, 2.5V \pm 5\%, 1.8V \pm 5\%$, $T_A = -40^\circ C$ to $+85^\circ C$ unless stated otherwise.

Symbol	Parameter	Conditions	Minimum	Typical	Maximum	Unit
V_{OH}	Output High Voltage	$I_{OH} = -15mA$ (3.3V), $-12mA$ (2.5V).	$0.7 \times V_{DDO}$	-	V_{DDO}	V
		$I_{OH} = -8mA$ (1.8V).	$0.7 \times V_{DDO}$	-	V_{DDO}	V
V_{OL}	Output Low Voltage	$I_{OL} = 15mA$ (3.3V), $12mA$ (2.5V), $8mA$ (1.8V).	-	-	0.45	V
R_{OUT}	Output Driver Impedance	CMOS output driver.	-	17	-	Ω
T_{SR}	Slew Rate, SLEW[1:0] = 00	Single-ended 3.3V LVCMOS output clock rise and fall time, 20% to 80% of V_{DDO} (output load = 5pF) $V_{DDOX} = 3.3V$.	1.0	2.2	-	V/ns
	Slew Rate, SLEW[1:0] = 01		1.2	2.3	-	
	Slew Rate, SLEW[1:0] = 10		1.3	2.4	-	
	Slew Rate, SLEW[1:0] = 11		1.7	2.7	-	
	Slew Rate, SLEW[1:0] = 00	Single-ended 2.5V LVCMOS output clock rise and fall time, 20% to 80% of V_{DDO} (output load = 5pF) $V_{DDOX} = 2.5V$.	0.6	1.3	-	
	Slew Rate, SLEW[1:0] = 01		0.7	1.4	-	
	Slew Rate, SLEW[1:0] = 10		0.6	1.4	-	
	Slew Rate, SLEW[1:0] = 11		1.0	1.7	-	
	Slew Rate, SLEW[1:0] = 00	Single-ended 1.8V LVCMOS output clock rise and fall time, 20% to 80% of V_{DDO} (output load = 5pF) $V_{DD} = 1.8V$.	0.3	0.7	-	
	Slew Rate, SLEW[1:0] = 01		0.4	0.8	-	
	Slew Rate, SLEW[1:0] = 10		0.4	0.9	-	
	Slew Rate, SLEW[1:0] = 11		0.7	1.2	-	
I_{OZDD}	Output Leakage Current (OUT1–4)	Tri-state outputs.	-	-	5	μA
	Output Leakage Current (OUT0)	Tri-state outputs.	-	-	30	μA

Table 10. Electrical Characteristics – LVDS Outputs

$V_{DDA}, V_{DDD}, V_{DDO0} = 3.3V \pm 5\%, 2.5V \pm 5\%, 1.8V \pm 5\%$, $T_A = -40^\circ C$ to $+85^\circ C$ unless stated otherwise.

Symbol	Parameter	Minimum	Typical	Maximum	Unit
$V_{OT (+)}$	Differential Output Voltage for the TRUE Binary State	247	-	454	mV
$V_{OT (-)}$	Differential Output Voltage for the FALSE Binary State	-454	-	-247	mV
ΔV_{OT}	Change in V_{OT} between Complimentary Output States	-	-	50	mV
V_{OS}	Output Common Mode Voltage (Offset Voltage) at 3.3 V $\pm 5\%$, 2.5V $\pm 5\%$	1.125	1.25	1.375	V
	Output Common Mode Voltage (Offset Voltage) at 1.8V $\pm 5\%$	0.8	0.875	0.96	V
ΔV_{OS}	Change in V_{OS} between Complimentary Output States	-	-	50	mV
I_{OS}	Outputs Short Circuit Current, V_{OUT+} or $V_{OUT-} = 0V$ or V_{DDO}	-	9	24	mA
I_{OSD}	Differential Outputs Short Circuit Current, $V_{OUT+} = V_{OUT-}$	-	6	12	mA
T_R	LVDS rise time 20%–80%	-	300	-	ps
T_F	LVDS fall time 80%–20%	-	300	-	ps

Table 11. Electrical Characteristics – LVPECL Outputs

V_{DDA} , V_{DDD} , V_{DDO0} = 3.3V ±5%, 2.5V ±5%, T_A = -40°C to +85°C unless stated otherwise.

Symbol	Parameter	Minimum	Typical	Maximum	Unit
V_{OH}	Output Voltage High, Terminated through 50Ω tied to V_{DD} - 2V	$V_{DDO} - 1.19$	-	$V_{DDO} - 0.69$	V
V_{OL}	Output Voltage Low, Terminated through 50Ω tied to V_{DD} - 2V	$V_{DDO} - 1.94$	-	$V_{DDO} - 1.4$	V
V_{SWING}	Peak-to-Peak Differential Output Voltage Swing	1.1	-	2	V
T_R	LVPECL rise time 20%–80%	-	400	-	ps
T_F	LVPECL fall time 80%–20%	-	400	-	ps

Table 12. Electrical Characteristics – HCSL Outputs ¹

V_{DDA} , V_{DDD} , V_{DDO0} = 3.3V ±5%, 2.5V ±5%, T_A = -40°C to +85°C unless stated otherwise.

Symbol	Parameter	Conditions	Minimum	Typical	Maximum	Unit
dV/dt	Slew Rate	Scope averaging on ^{2,3} .	1	-	4	V/ns
ΔdV/dt	Slew Rate Matching	Scope averaging on ^{2,3} .	-	-	20	%
V_{MAX}	Maximum Voltage	Measurement on single-ended signal using absolute value (scope averaging off).	-	-	1150	mV
V_{MIN}	Minimum Voltage		-300	-	-	mV
V_{SWING}	Voltage Swing	Scope averaging off ^{2,6} .	300	-	-	mV
V_{CROSS}	Crossing Voltage Value	Scope averaging off ^{4,6} .	250	-	550	mV
Δ V_{CROSS}	Crossing Voltage Variation	Scope averaging off ⁵ .	-	-	140	mV

¹ Guaranteed by design and characterization. Not 100% tested in production.

² Measured from differential waveform.

³ Slew rate is measured through the V_{SWING} voltage range centered around differential 0V. This results in a ±150mV window around differential 0V.

⁴ V_{CROSS} is defined as voltage where Clock = Clock# measured on a component test board and only applies to the differential rising edge (i.e. Clock rising and Clock# falling).

⁵ The total variation of all V_{CROSS} measurements in any particular system. Note that this is a subset of V_{CROSS} min/max (V_{CROSS} absolute) allowed. The intent is to limit V_{CROSS} induced modulation by setting Δ V_{CROSS} to be smaller than V_{CROSS} absolute.

⁶ Measured from single-ended waveform.

Table 13. Spread Spectrum Generation Specifications

Symbol	Parameter	Conditions	Minimum	Typical	Maximum	Unit
f_{SSOUT}	Spread Frequency	Output frequency range for spread spectrum.	5	-	300	MHz
f_{MOD}	Mod Frequency	Modulation frequency.	30 to 63			kHz
f_{SPREAD}	Spread Value	Amount of spread value (programmable)–center spread.	±0.1% to ±2.5%			% f_{OUT}
		Amount of spread value (programmable)–down spread.	-0.2% to -5%			

I²C Bus Characteristics

Table 14. I²C Bus (SCL/SDA) DC Characteristics

Symbol	Parameter	Conditions	Minimum	Typical	Maximum	Unit
V _{IH}	Input High Level	For SEL1/SDA pin and SEL0/SCL pin.	0.7 x V _{DDD}	-	-	V
V _{IL}	Input Low Level	For SEL1/SDA pin and SEL0/SCL pin.	-	-	0.3 x V _{DDD}	V
V _{HYS}	Hysteresis of Inputs		0.05 x V _{DDD}	-		V
I _{IN}	Input Leakage Current		-1	-	36	μA
V _{OL}	Output Low Voltage	I _{OL} = 3mA.	-	-	0.45	V

Table 15. I²C Bus (SCL/SDA) AC Characteristics

Symbol	Parameter	Conditions	Minimum	Typical	Maximum	Unit
F _{SCLK}	Serial Clock Frequency (SCL)	-	10	-	400	kHz
t _{BUF}	Bus Free Time between Stop and Start	-	1.3	-	-	μs
t _{SU:START}	Setup Time, Start	-	0.6	-	-	μs
t _{HD:START}	Hold Time, Start	-	0.6	-	-	μs
t _{SU:DATA}	Setup Time, Data Input (SDA)	-	0.1	-	-	μs
t _{HD:DATA}	Hold Time, Data Input (SDA) ¹	-	0	-	-	μs
t _{OVD}	Output Data Valid from Clock	-	-	-	0.9	μs
C _B	Capacitive Load for Each Bus Line	-	-	-	400	pF
t _R	Rise Time, Data and Clock (SDA, SCL)	-	20 + 0.1 x C _B	-	300	ns
t _F	Fall Time, Data and Clock (SDA, SCL)	-	20 + 0.1 x C _B	-	300	ns
t _{HIGH}	High Time, Clock (SCL)	-	0.6	-	-	μs
t _{LOW}	Low Time, Clock (SCL)	-	1.3	-	-	μs
t _{SU:STOP}	Setup Time, Stop	-	0.6	-	-	μs

¹ A device must internally provide a hold time of at least 300ns for the SDA signal (referred to the V_{IH(MIN)} of the SCL signal) to bridge the undefined region of the falling edge of SCL.

² I²C inputs are 3.3V tolerant.

Test Loads

Figure 2. LVCMOS Test Load

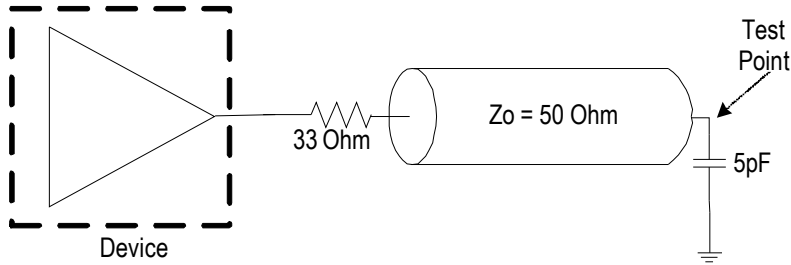

Figure 3. HCSL Test Load

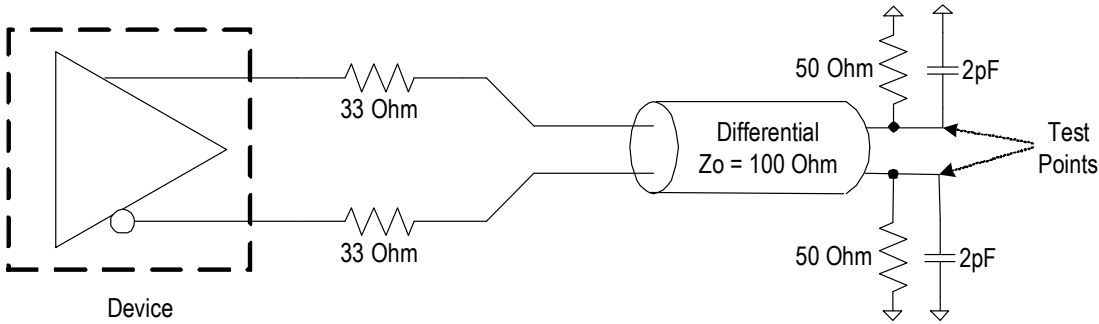

Figure 4. LVDS Test Load

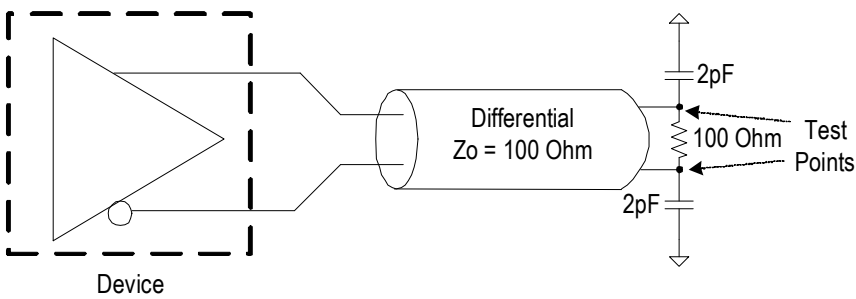
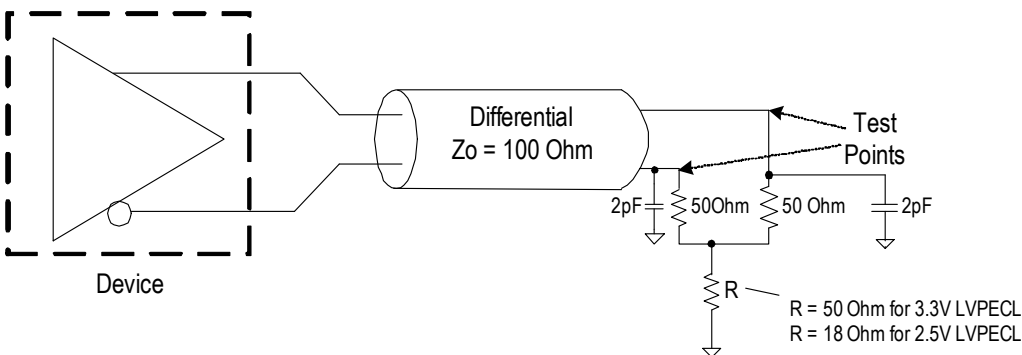
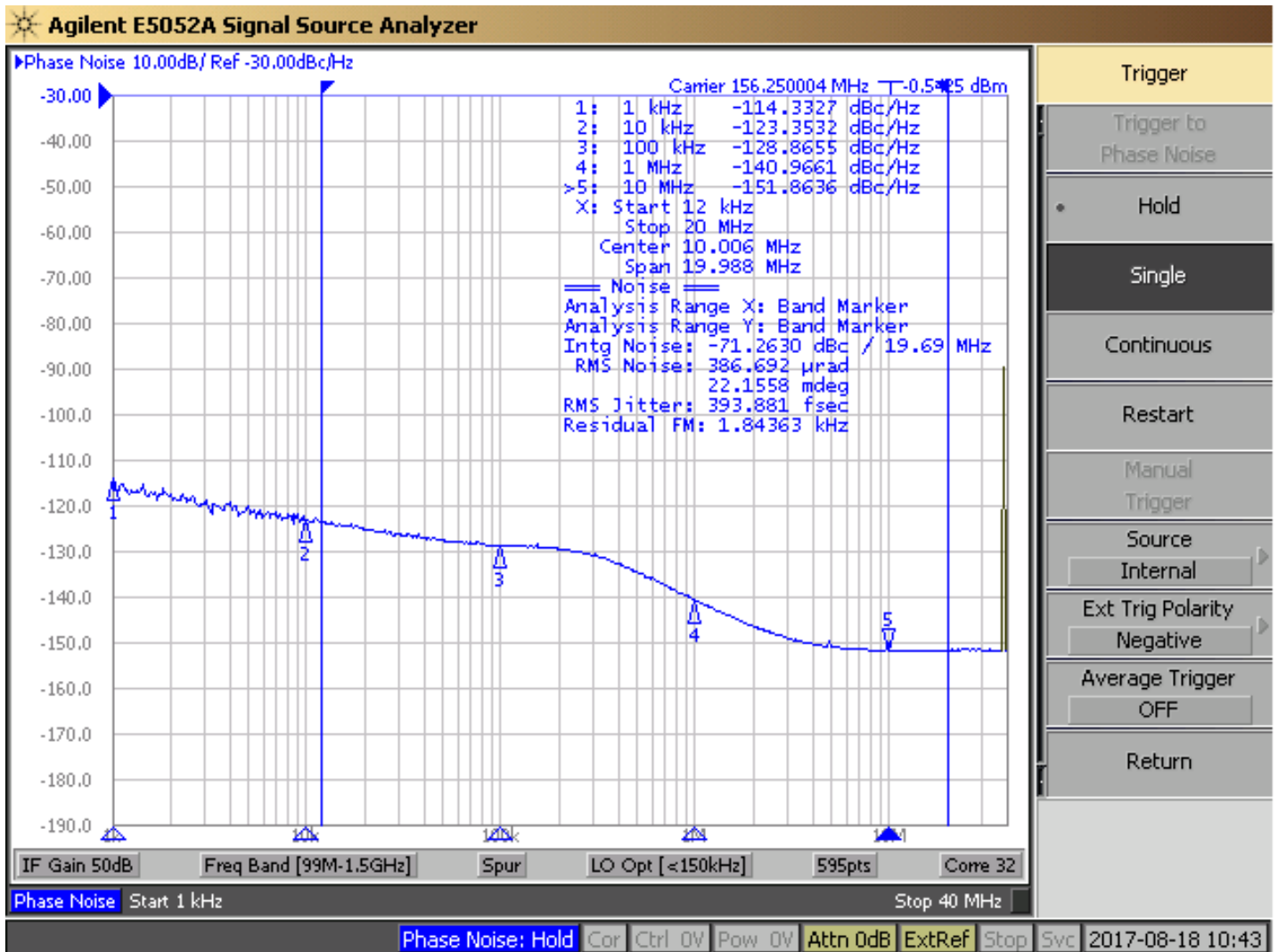

Figure 5. LVPECL Test Load



Jitter Performance Characteristics

Figure 6. Typical Phase Jitter Plot at 156.25MHz



Note: Measured with OUT2 = 156.25MHz on, 39.625MHz input.

Table 16. Jitter Performance ^{1,2}

Symbol	Parameter	Conditions	Minimum	Typical	Maximum	Unit
J _{CY-CY}	Cycle to Cycle Jitter	LVC MOS 3.3V ±5%, -40°C–90°C.	-	5	30	ps
		All differential outputs 3.3V ±5%, -40°C–90°C.	-	25	35	ps
J _{PK-PK}	Period Jitter	LVC MOS 3.3V ±5%, -40°C–90°C.	-	28	40	ps
		All differential outputs 3.3V ±5%, -40°C–90°C.	-	4	30	ps
J _{RMS}	RMS Phase Jitter (12kHz–20MHz)	LVC MOS 3.3V ±5%, -40°C–90°C.	-	0.3	-	ps
		All differential outputs 3.3V ±5%, -40°C–90°C.	-	0.5	-	ps

¹ Measured with 25MHz crystal input.

² Configured with OUT0 = 25MHz–LVC MOS; OUT1 = 100MHz–HCSL; OUT2 = 125MHz–LVDS; OUT3 = 156.25MHz–LVPECL.

PCI Express Jitter Performance and Specification

Table 17. PCI Express Jitter Performance (Spread Spectrum = Off)

Parameter	Symbol	Conditions	Minimum	Typical	Maximum	Limit	Unit	Notes
PCIe Phase Jitter (Common Clocked Architectures)	$t_{jphPCIeG1-CC}$	PCIe Gen1 (2.5 GT/s) SSC = OFF	-	4	-	86	ps (p-p)	1,2
	$t_{jphPCIeG2-CC}$	PCIe Gen2 Lo Band (5.0 GT/s) SSC = OFF	-	0.05	-	3	ps (RMS)	1,2
		PCIe Gen2 Hi Band (5.0 GT/s) SSC = OFF	-	0.22	-	3.1	ps (RMS)	1,2
	$t_{jphPCIeG3-CC}$	PCIe Gen3 (8.0 GT/s) SSC = OFF	-	0.12	-	1	ps (RMS)	1,2
	$t_{jphPCIeG4-CC}$	PCIe Gen4 (16.0 GT/s) SSC = OFF	-	0.12	-	0.5	ps (RMS)	1,2,3,4
	$t_{jphPCIeG5-CC}$	PCIe Gen5 (32.0 GT/s) SSC = OFF	-	0.05	-	0.15	ps (RMS)	1,2,3,5
PCIe Phase Jitter (SRNS Architectures)	$t_{jphPCIeG1-SRNS}$	PCIe Gen1 (2.5 GT/s) SSC = OFF	-	0.3	-	N/A	ps (p-p)	1,2,6
	$t_{jphPCIeG2-SRNS}$	PCIe Gen2 (5.0 GT/s) SSC = OFF	-	0.26	-		ps (RMS)	1,2,6
	$t_{jphPCIeG3-SRNS}$	PCIe Gen3 (8.0 GT/s) SSC = OFF	-	0.07	-		ps (RMS)	1,2,6
	$t_{jphPCIeG4-SRNS}$	PCIe Gen4 (16.0 GT/s) SSC = OFF	-	0.07	-		ps (RMS)	1,2,6
	$t_{jphPCIeG5-SRNS}$	PCIe Gen5 (32.0 GT/s) SSC = OFF	-	0.07	-		ps (RMS)	1,2,6

¹ The Refclk jitter is measured after applying the filter functions found in PCI Express Base Specification 5.0, Revision 1.0. See the **Test Loads** section of the data sheet for the exact measurement setup. The worst case results for each data rate are summarized in this table.

² Jitter measurements shall be made with a capture of at least 100,000 clock cycles captured by a real-time oscilloscope (RTO) with a sample rate of 20GS/s or greater. Broadband oscilloscope noise must be minimized in the measurement. The measured PP jitter is used (no extrapolation) for RTO measurements. Alternately, jitter measurements may be used with a Phase Noise Analyzer (PNA) extending (flat) and integrating and folding the frequency content up to an offset from the carrier frequency of at least 200MHz (at 300MHz absolute frequency) below the Nyquist frequency. For PNA measurements for the 2.5GT/s data rate, the RMS jitter is converted to peak to peak jitter using a multiplication factor of 8.83. In the case where real-time oscilloscope and PNA measurements have both been done and produce different results, the RTO result must be used.

³ SSC spurs from the fundamental and harmonics are removed up to a cutoff frequency of 2MHz taking care to minimize removal of any non-SSC content.

⁴ Note that 0.7ps RMS is to be used in channel simulations to account for additional noise in a real system.

⁵ Note that 0.25ps RMS is to be used in channel simulations to account for additional noise in a real system.

⁶ While the PCI Express Base Specification 5.0, Revision 1.0 provides the filters necessary to calculate SRIS jitter values, it does not provide specification limits, hence the n/a in the Limit column. SRIS values are informative only. In general, a clock operating in an SRIS system must be twice as good as a clock operating in a Common Clock system. For RMS values, twice as good is equivalent to dividing the CC value by Ö2.

Table 18. PCI Express Jitter Performance (Spread Spectrum = On)

Parameter	Symbol	Conditions	Minimum	Typical	Maximum	Limit	Unit	Notes
PCIe Phase Jitter (Common Clocked Architectures)	$t_{jphPCIeG1-CC}$	PCIe Gen 1 (2.5 GT/s) SSC \leq -0.5%	-	16	-	86	ps (p-p)	1,2
	$t_{jphPCIeG2-CC}$	PCIe Gen 2 Lo Band (5.0 GT/s) SSC \leq -0.5%	-	0.02	-	3	ps (RMS)	1,2
		PCIe Gen 2 Hi Band (5.0 GT/s) SSC \leq -0.5%	-	0.92	-	3.1	ps (RMS)	1,2
	$t_{jphPCIeG3-CC}$	PCIe Gen 3 (8.0 GT/s) SSC \leq -0.5%	-	0.37	-	1	ps (RMS)	1,2
	$t_{jphPCIeG4-CC}$	PCIe Gen 4 (16.0 GT/s) SSC \leq -0.5%	-	0.37	-	0.5	ps (RMS)	1,2,3,4
	$t_{jphPCIeG5-CC}$	PCIe Gen 5 (32.0 GT/s) SSC \leq -0.5%	-	N/A	-	0.15	ps (RMS)	1,2,3,5
PCIe Phase Jitter (SRIS Architectures)	$t_{jphPCIeG1-SRIS}$	PCIe Gen 1 (2.5 GT/s) SSC \leq -0.3%	-	14	-	N/A	ps (p-p)	1,2,6
	$t_{jphPCIeG2-SRIS}$	PCIe Gen 2 (5.0 GT/s) SSC \leq -0.3%	-	1.4	-		ps (RMS)	1,2,6
	$t_{jphPCIeG3-SRIS}$	PCIe Gen 3 (8.0 GT/s) SSC \leq -0.3%	-	0.42	-		ps (RMS)	1,2,6
	$t_{jphPCIeG4-SRIS}$	PCIe Gen 4 (16.0 GT/s) SSC \leq -0.3%	-	0.36	-		ps (RMS)	1,2,6
	$t_{jphPCIeG5-SRIS}$	PCIe Gen 5 (32.0 GT/s) SSC \leq -0.3%	-	N/A	-		ps (RMS)	1,2,6

¹ The Refclk jitter is measured after applying the filter functions found in PCI Express Base Specification 5.0, Revision 1.0. See the [Test Loads](#) section of the data sheet for the exact measurement setup. The worst case results for each data rate are summarized in this table.

² Jitter measurements shall be made with a capture of at least 100,000 clock cycles captured by a real-time oscilloscope (RTO) with a sample rate of 20GS/s or greater. Broadband oscilloscope noise must be minimized in the measurement. The measured PP jitter is used (no extrapolation) for RTO measurements. Alternately, jitter measurements may be used with a Phase Noise Analyzer (PNA) extending (flat) and integrating and folding the frequency content up to an offset from the carrier frequency of at least 200MHz (at 300MHz absolute frequency) below the Nyquist frequency. For PNA measurements for the 2.5GT/s data rate, the RMS jitter is converted to peak to peak jitter using a multiplication factor of 8.83. In the case where real-time oscilloscope and PNA measurements have both been done and produce different results, the RTO result must be used.

³ SSC spurs from the fundamental and harmonics are removed up to a cutoff frequency of 2MHz taking care to minimize removal of any non-SSC content.

⁴ Note that 0.7ps RMS is to be used in channel simulations to account for additional noise in a real system.

⁵ Note that 0.25ps RMS is to be used in channel simulations to account for additional noise in a real system.

⁶ While the PCI Express Base Specification 5.0, Revision 1.0 provides the filters necessary to calculate SRIS jitter values, it does not provide specification limits, hence the n/a in the Limit column. SRIS values are informative only. In general, a clock operating in an SRIS system must be twice as good as a clock operating in a Common Clock system. For RMS values, twice as good is equivalent to dividing the CC value by Ö2.

Features and Functional Blocks

Device Startup and Power-On-Reset

The device has an internal power-up reset (POR) circuit. All V_{DDs} must be connected to desired supply voltage to trigger POR.

User can define specific default configurations through internal One-Time-Programmable (OTP) memory. Either customer or factory can program the default configuration. Please refer to [VersaClock 6E Family Register Descriptions and Programming Guide](#) for details or contact Renesas if a specific factory-programmed default configuration is required.

Device will identify which of the 2 modes to operate in by the state of `OUT0_SEL_I2CB` pin at POR. Both of the 2 modes default configurations can be programmed as stated above.

- Software Mode (I²C):** `OUT0_SEL_I2CB` is low at POR. I²C interface will be open to users for in-system programming, overriding device default configurations at any time.
- Hardware Select Mode:** `OUT0_SEL_I2CB` is high at POR. Device has been programmed to load OTP at power-up (`REG0[7]=1`). The device will load internal registers according to [Table 19. Power-up Behavior](#).

Internal OTP memory can support up to 4 configurations, selectable by `SEL0/SEL1` pins.

At POR, logic levels at `SEL0` and `SEL1` pins must be settled, resulting the selected configuration to be loaded at power up.

After the first 10ms of operation, the levels of the `SELx` pins can be changed, either to low or to the same level as V_{DD0}/V_{DDA} . The `SELx` pins must be driven with a digital signal of < 300ns rise/fall time and only a single pin can be changed at a time. After a pin level change, the device must not be interrupted for at least 1ms so that the new values have time to load and take effect.

Table 19. Power-up Behavior

OUT0_SEL_I2CB at POR	SEL1	SEL0	I ² C Access	REG0:7	Config
1	0	0	No	0	0
1	0	1	No	0	1
1	1	0	No	0	2
1	1	1	No	0	3
0	X	X	Yes	1	I ² C defaults
0	X	X	Yes	0	0

Reference Clock and Selection

The device supports up to two clock inputs.

- Crystal input, can be driven by a single-ended clock.
- Clock input (`CLKIN`, `CLKINB`), a fully differential input that only accepts a reference clock. A single-ended clock can also drive it on `CLKIN`.

Figure 7. Clock Input Diagram, Internal Logic

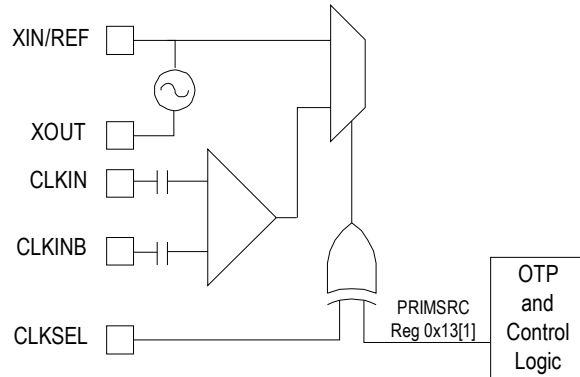

Manual Switchover

The `CLKSEL` pin selects the input clock between either `XTAL/REF` or (`CLKIN`, `CLKINB`).

`CLKSEL` polarity can be changed by I²C programming (Byte `0x13[1]`) as shown in the table below.

0 = `XIN/REF`, `XOUT` (default); 1 = `CLKIN`, `CLKINB`.

Table 20. Input Clock Select

PRIMSRC	CLKSEL	Source
0	0	XIN/REF
0	1	CLKIN, CLKINB
1	0	CLKIN, CLKINB
1	1	XIN/REF

When `SM[1:0]` is "0x", the redundant inputs are in manual switchover mode. In this mode, `CLKSEL` pin is used to switch between the primary and secondary clock sources. The `PRIMSRC` bit determines the primary and secondary clock source setting. During the switchover, no glitches will occur at the output of the device, although there may be frequency and phase drift, depending on the exact phase and frequency relationship between the primary and secondary clocks.

Internal Crystal Oscillator (XIN/REF)

Choosing Crystals

A crystal manufacturer will calibrate its crystals to the nominal frequency with a certain load capacitance value. When the oscillator load capacitance matches the crystal load capacitance, the oscillation frequency will be accurate. When the oscillator load capacitance is lower than the crystal load capacitance, the oscillation frequency will be higher than nominal and vice versa so for an accurate oscillation frequency you need to make sure to match the oscillator load capacitance with the crystal load capacitance.

Tuning the Crystal Load Capacitor

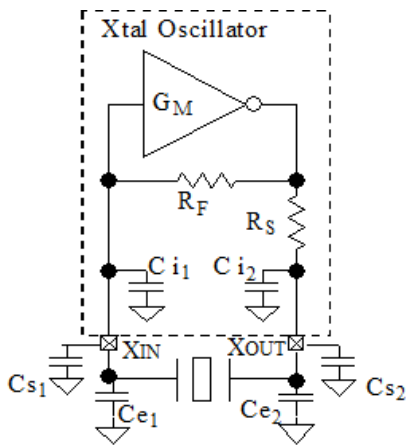

Cs1 and Cs2 are stray capacitances at each crystal pin and typical values are between 1pF and 3pF.

Ce1 and Ce2 are additional external capacitors, increasing the load capacitance reduces the oscillator gain so please consult the factory when adding Ce1 and/or Ce2 to avoid crystal startup issues. Ci1 and Ci2 are integrated programmable load capacitors, one at XIN and one at XOUT. Ci1 and Ci2.

The value of each capacitor is composed of a fixed capacitance amount plus a variable capacitance amount set with the XTAL[5:0] register.

Table 22. Recommended Crystal Characteristics

Parameter	Minimum	Typical	Maximum	Unit
Mode of Oscillation	Fundamental			
Frequency	8	25	40	MHz
Equivalent Series Resistance (ESR)	-	10	100	Ω
Shunt Capacitance	-	-	7	pF
Load Capacitance (CL) at <= 25MHz	6	8	12	pF
Load Capacitance (CL) > 25MHz to 40MHz	6	-	8	pF
Maximum Crystal Drive Level	-	-	100	μW

Ci1 and Ci2 are commonly programmed to be the same value. Adjustment of the crystal tuning capacitors allows maximum flexibility to accommodate crystals from various manufacturers. The range of tuning capacitor values available are in accordance with the following table.

Ci1/Ci2 starts at 9pF with setting 000000b and can be increased up to 25pF with setting 111111b. The step per bit is 0.5pF.

Table 21. XTAL[5:0] Tuning Capacitor

Parameter	Bits	Step (pF)	Minimum (pF)	Maximum (pF)
XTAL	6	0.5	9	25

You can write the following equation for this capacitance:

$$C_i = 9pF + 0.5pF \times XTAL[5:0]$$

$$C_{XIN} = C_{i1} + C_{s1} + C_{e1}$$

$$C_{XOUT} = C_{i2} + C_{s2} + C_{e2}$$

The final load capacitance of the crystal:

$$C_L = C_{XIN} \times C_{XOUT} / (C_{XIN} + C_{XOUT})$$

It is recommended to set the same value for capacitors the same at each crystal pin, meaning:

$$C_{XIN} = C_{XOUT}$$

Example 1: The crystal load capacitance is specified as 8pF and the stray capacitance at each crystal pin is Cs = 1.5pF. Assuming equal capacitance value at XIN and XOUT, the equation is as follows:

$$8pF = (9pF + 0.5pF \times XTAL[5:0] + 1.5pF) / 2$$

$$\text{So, } XTAL[5:0] = 11 \text{ (decimal).}$$

Example 2: The crystal load capacitance is specified as 12pF and the stray capacitance Cs is unknown. Footprints for external capacitors Ce are added and a worst case Cs of 5pF is used. For now we use Cs + Ce = 5pF and the right value for Ce can be determined later to make 5pF together with Cs.

$$12pF = (9pF + 0.5pF \times XTAL[5:0] + 5pF) / 2$$

$$\text{So, } XTAL[5:0] = 20 \text{ (decimal).}$$

Programmable Loop Filter

The device PLL loop bandwidth range depends on the input reference frequency (Fref).

Table 23. Loop Filter Settings

Input Reference Frequency (MHz)	Loop Bandwidth Minimum (kHz)	Loop Bandwidth Maximum (kHz)
1	40	126
350	300	1000

Fractional Output Dividers (FOD)

The device has 4 fractional output dividers (FOD). Each of the FODs are comprised of a 12-bit integer counter, and a 24-bit fractional counter. The output divider can operate in integer divide only mode for improved performance, or utilize the fractional counters to generate a clock frequency accurate to 50ppb.

FOD has the following features:

Individual Spread Spectrum Modulation

The output clock frequencies can be modulated to spread energy across a broader range of frequencies, lowering system EMI.

Each divider has individual spread ability. Spread modulation independent of output frequency, a triangle wave modulation between 30 and 63kHz.

Spread spectrum can be applied to any output clock, any clock frequency, and any spread amount from $\pm 0.25\%$ to $\pm 2.5\%$ center-spread and -0.5% to -5% down-spread.

Bypass Mode

Bypass mode (divide by 1) to allow the output to behave as a buffered copy from the input or another FOD.

Cascaded Mode

As shown in the block diagram, FODs can be cascaded for lower output frequency.

For example, user currently has OUT1 running at 12.288MHz and needs another 48kHz output. The user can cascade FOD2 by taking input from OUT1, with a divide ratio of 256. In this way, OUT 2 is running at 48kHz while in alignment with 12.288MHz on OUT1.

Dividers Alignment

Each output divider block has a synchronizing pulse to provide startup alignment between outputs dividers. This allows alignment of outputs for low skew performance.

When device is at hardware select mode outputs will be automatically aligned at POR. The same synchronization reset is also triggered when switching between configurations with the SEL0/1 pins. This ensures that the outputs remain aligned in every configuration.

When using software mode I²C to reprogram an output divider during operation, alignment can be lost. Alignment can be restored by manually triggering the reset through I²C.

The outputs are aligned on the falling edges of each output by default. Rising edge alignment can also be achieved by utilizing the programmable skew feature to delay the faster clock by 180 degrees. The programmable skew feature also allows for fine tuning of the alignment.

Programmable Skew

The device has the ability to skew outputs by quadrature values. The skew on each output can be adjusted from 0 to 360 degrees. Skew is adjusted in units equal to 1/32 of the VCO period. So, for 100MHz output and a 2800MHz VCO, you can select how many 11.161ps units you want added to your skew (resulting in units of 0.402 degrees). For example, 0, 0.402, 0.804, 1.206, 1.408, and so on. The granularity of the skew adjustment is always dependent on the VCO period and the output period.

Output Drivers

The device output drivers support the following features individually:

- 2.5V or 3.3V voltage level for HCSL/LVPECL operation
- 1.8V, 2.5V or 3.3V voltage levels for CMOS/LVDS operation
- CMOS supports 4 operating modes:
 - CMOSD: OUTx and OUTxB 180 degrees out of phase
 - CMOSX2: OUTx and OUTxB phase-aligned
 - CMOS1: only OUTx pin is on
 - CMOS2: only OUTxB pin is on

When a given output is configured to at CMOSD or CMOSX2, then all previously described configuration and control apply equally to both pins.

- Independent output enable/disabled by register bits. When disabled, an output can be either in a logic 1 state or Hi-Z.

The following options are used to disable outputs:

1. Output turned off by I²C.
2. Output turned off by SD/OE pin.
3. Output unused, which means is turned off regardless of OE pin status.

SD/OE Pin Function

SD/OE pin can be programmed as following functions:

1. OE output enable (low active).
2. OE output enable (high active).
3. Global shutdown (low active).
4. Global shutdown (high active).

Output behavior when disabled is also programmable. User will have the option to choose output driver behavior when it's off:

1. OUTx pin high, OUTxB pin low. (Controlled by SD/OE pin).
2. OUTx/OUTxB Hi-Z (Controlled by SD/OE pin).
3. OUTx pin high, OUTxB pin low. (Configured through I²C).
4. OUTx/OUTxB Hi-Z (Configured by I²C).

The user has the option to disable the output with either I²C or SD/OE pin. Refer to [VersaClock 6E Family Register Descriptions and Programming Guide](#) for details.

I²C Operation

The device acts as a slave device on the I²C bus using one of the two I²C addresses (0xD0 or 0xD4) to allow multiple devices to be used in the system. The interface accepts byte-oriented block write and block read operations.

Address bytes(2 bytes) specify the register address of the byte position of the first register to write or read.

Data bytes (registers) are accessed in sequential order from the lowest to the highest byte (most significant bit first).

Read and write block transfers can be stopped after any complete byte transfer. During a write operation, data will not be moved into the registers until the STOP bit is received, at which point, all data received in the block write will be written simultaneously.

For full electrical I²C compliance, use external pull-up resistors for SDATA and SCLK.

Figure 8. I²C R/W Sequence

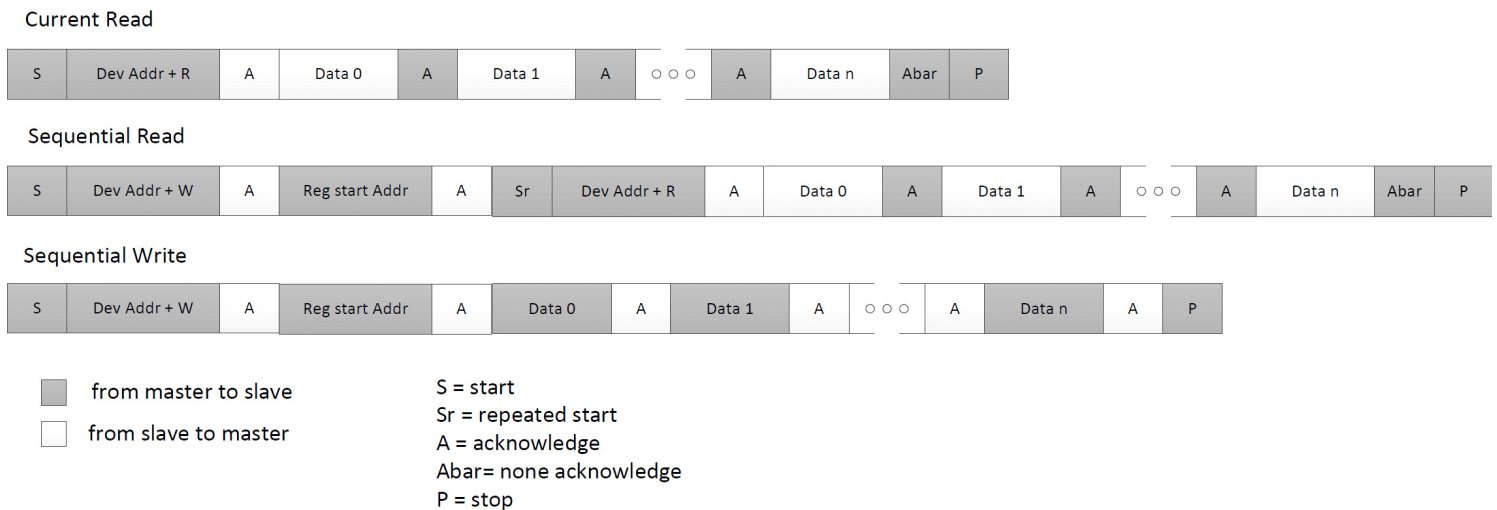

Typical Application Circuits

Figure 9. Application Circuit Example

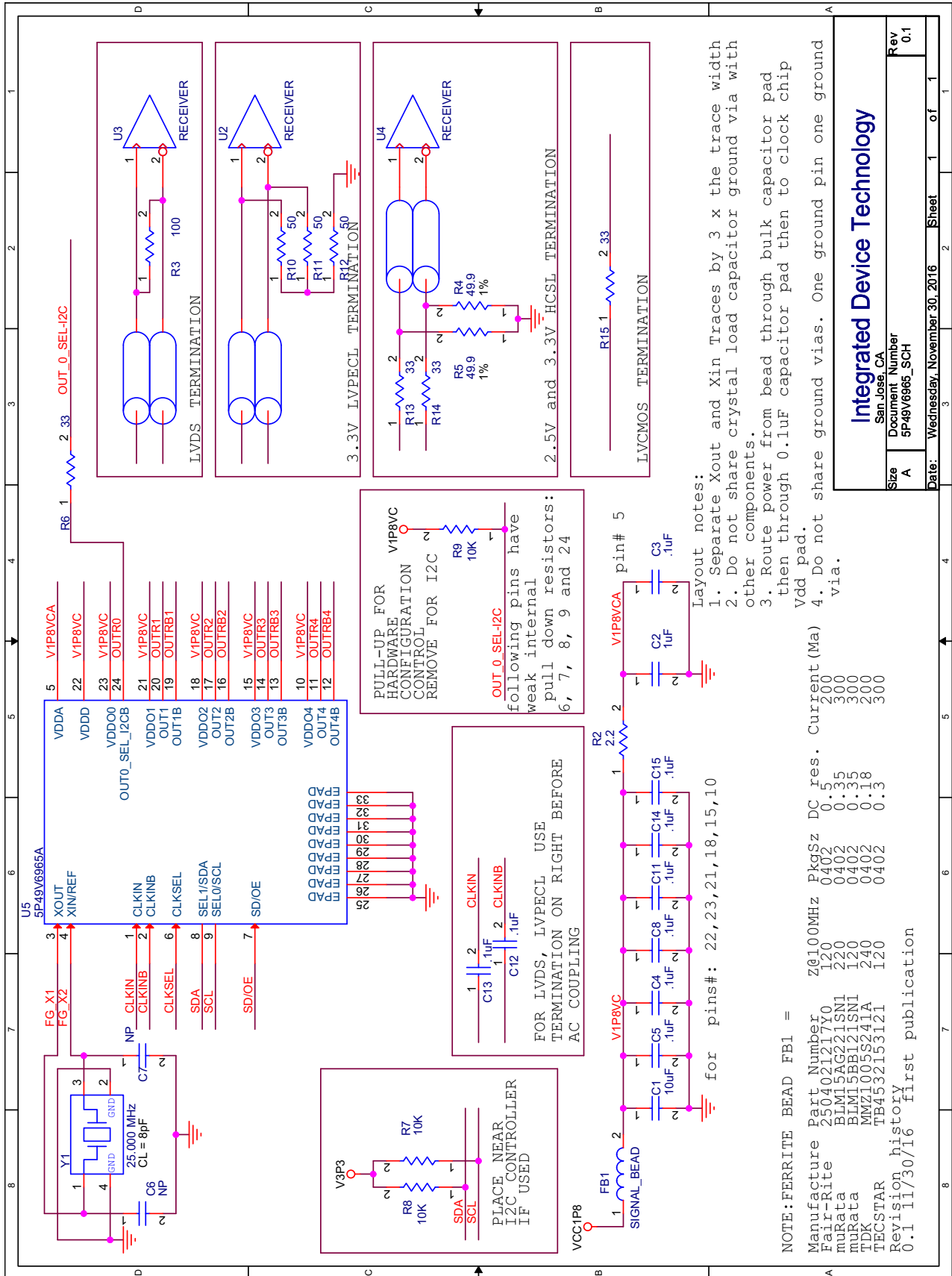

Size	A	Document Number	5P49V6965_SCH
Date:	Wednesday, November 30, 2016	Sheet	1 of 1
Integrated Device Technology		San Jose, CA	
Rev	0.1		

Input – Driving the XIN/REF or CLKIN

Driving XIN/REF with a CMOS Driver

In some cases, it is encouraged to have XIN/REF driven by a clock input for reasons like better SNR, multiple input select with device CLKIN, etc. The XIN/REF pin is able to take an input when its amplitude is between 500mV and 1.2V and the slew rate more than 0.2V/ns.

The XIN/REF input can be overdriven by an LVCMOS driver or by one side of a differential driver through an AC coupling capacitor. The XOUT pin can be left floating.

Figure 10. Overdriving XIN with a CMOS Driver

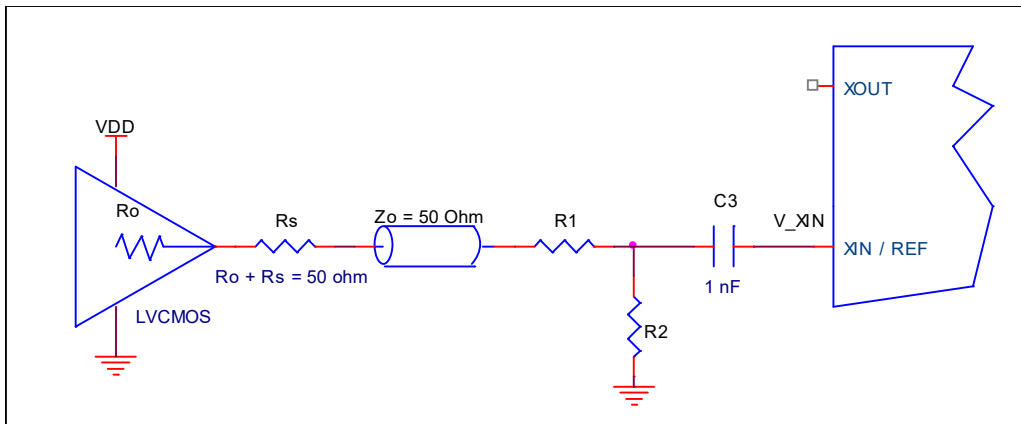

Table 24. Nominal Voltage Divider Values for Overdriving XIN with Single-ended Driver

LVCMOS Diver V_{DD}	$R_o + R_s$	R_1	R_2	V_{XIN} (peak)	$R_o+R_s+R_1+R_2$
3.3	50.0	130	75	0.97	255
2.5	50.0	100	100	1.00	250
1.8	50.0	62	130	0.97	242

Driving XIN with an LVPECL Driver

Figure 11 shows an example of the interface diagram for a +3.3V LVPECL driver. This is a standard LVPECL termination with one side of the driver feeding the XIN/REF input. It is recommended that all components in the schematics be placed in the layout; though some components might not be used, they can be utilized for debugging purposes. The datasheet specifications are characterized and guaranteed by using a quartz crystal as the input. If the driver is 2.5V LVPECL, the only change necessary is to use the appropriate value of R3.

Figure 11. Overdriving XIN with an LVPECL Driver

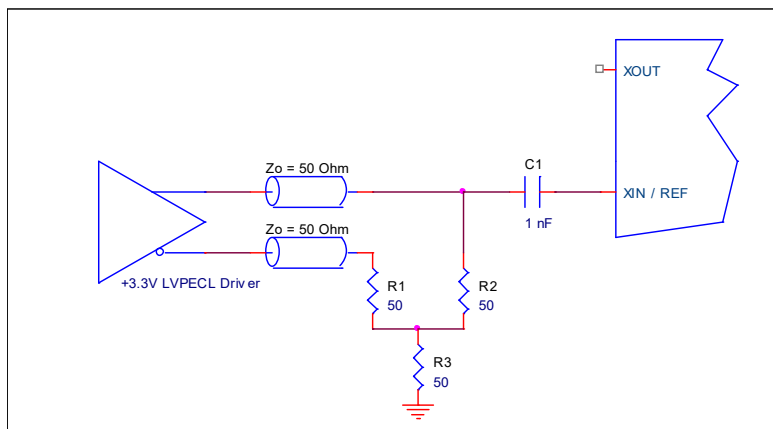

Wiring the CLKIN Pin to Accept Single-ended Inputs

CLKIN cannot take a signal larger than 1.2V pk-pk due to the 1.2V regulated input inside. However, it is internally AC coupled so it is able to accept both LVDS and LVPECL input signals.

Occasionally, it is desired to have CLKIN to take CMOS levels. Below is an example showing how this can be achieved.

This configuration has three properties:

1. Total output impedance of R_o and R_s matches the 50Ω transmission line impedance.
2. V_{rx} voltage is generated at the CLKIN which maintains the LVCMOS driver voltage level across the transmission line for best S/N.
3. R_1 – R_2 voltage divider values ensure that V_{rx} p-p at CLKIN is less than the maximum value of 1.2V.

Figure 12. Recommended Schematic for Driving CLKIN with LVCMOS Driver

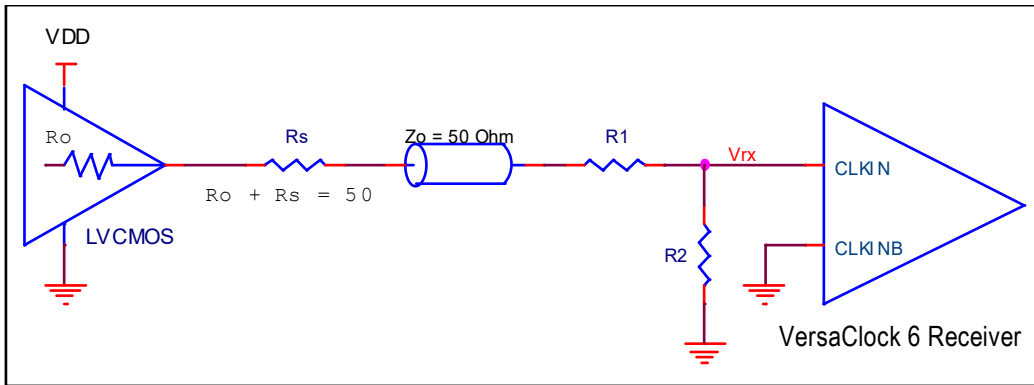

Table 25 shows resistor values that ensure the maximum drive level for the CLKIN port is not exceeded for all combinations of 5% tolerance on the driver V_{DD} , V_{DD00} and 5% resistor tolerances. The values of the resistors can be adjusted to reduce the loading for slower and weaker LVCMOS driver by increasing the impedance of the R_1 – R_2 divider. To better assist this assessment, the total load ($R_o + R_s + R_1 + R_2$) on the driver is included in the table.

Table 25. Nominal Voltage Divider Values for Overdriving CLKIN with Single-ended Driver

LVCMOS Diver V_{DD}	$R_o + R_s$	R_1	R_2	V_{rx} (peak)	$R_o+R_s+R_1+R_2$
3.3	50.0	130	75	0.97	255
2.5	50.0	100	100	1.00	250
1.8	50.0	62	130	0.97	242

Driving CLKIN with Differential Clock

CLKIN/CLKINB will accept DC coupled HCSL/LVPECL/LVDS signals.

Figure 13. CLKIN, CLKINB Input Driven by an HCSL Driver

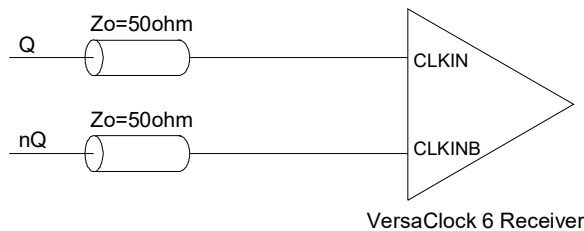

Output – Single-ended or Differential Clock Terminations

LVDS Termination

For a general LVDS interface, the recommended value for the termination impedance (Z_T) is between 90Ω and 132Ω . The actual value should be selected to match the differential impedance (Z_0) of your transmission line. A typical point-to-point LVDS design uses a 100Ω parallel resistor at the receiver and a 100Ω differential transmission-line environment. In order to avoid any transmission-line reflection issues, the components should be surface mounted and must be placed as close to the receiver as possible. The standard termination schematic as shown in figure [Standard Termination](#) or the termination of figure [Optional Termination](#) can be used, which uses a center tap capacitance to help filter common mode noise. The capacitor value should be approximately 50pF . In addition, since these outputs are LVDS compatible, the input receiver's amplitude and common-mode input range should be verified for compatibility with the Renesas LVDS output. If using a non-standard termination, it is recommended to contact Renesas and confirm that the termination will function as intended.

Figure 14. Standard and Optional Terminations

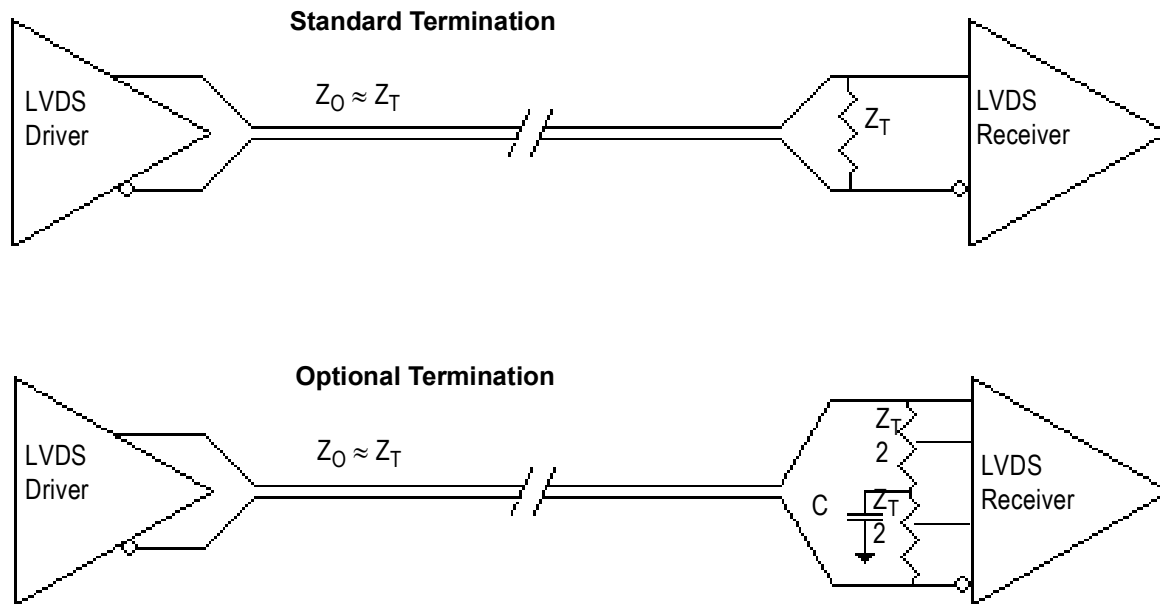

LVPECL Termination

The clock layout topology shown below is a typical termination for LVPECL outputs.

The differential outputs generate ECL/LVPECL compatible outputs. Therefore, terminating resistors (DC current path to ground) or current sources must be used for functionality. These outputs are designed to drive 50Ω transmission lines. Matched impedance techniques should be used to maximize operating frequency and minimize signal distortion.

For $V_{DDO} = 2.5V$, the $V_{DDO} - 2V$ is very close to ground level. The R3 in 2.5V LVPECL output termination can be eliminated and the termination is shown in [Figure 17](#), 2.5V LVPECL Output Termination.

Figure 15. 3.3V LVPECL Output Termination (1)

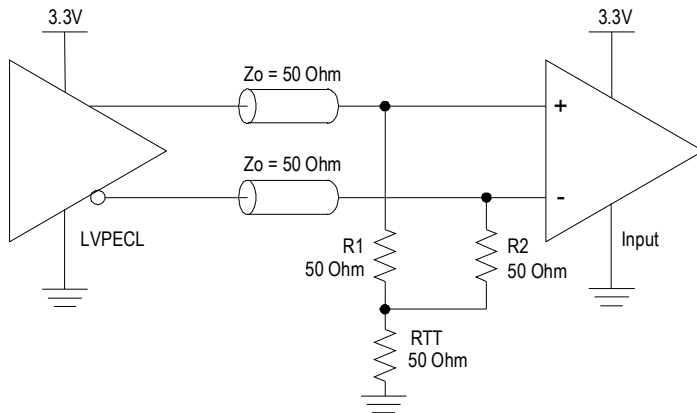

Figure 16. 3.3V LVPECL Output Termination (2)

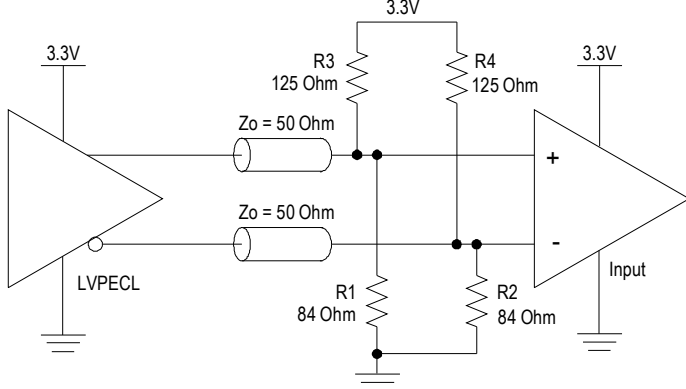

Figure 17. 2.5V LVPECL Output Termination

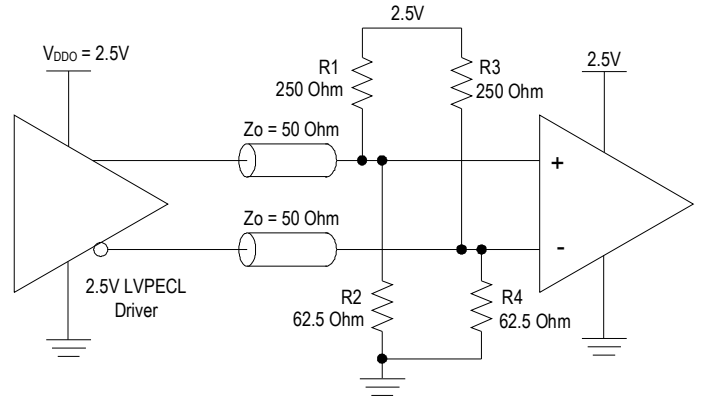

Figure 18. 2.5V LVPECL Driver Termination (1)

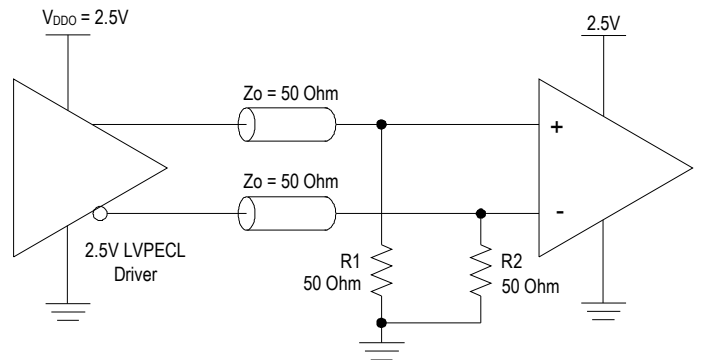
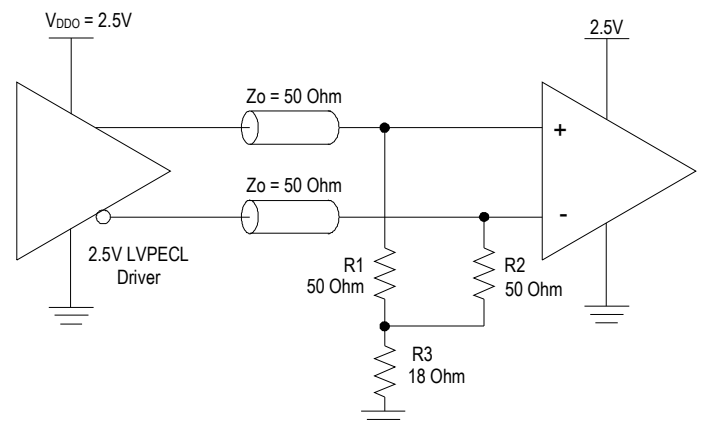

Figure 19. 2.5V LVPECL Driver Termination (2)



HCSL Termination

HCSL termination scheme applies to both 3.3V and 2.5V V_{DDO} .

Figure 20. HCSL Receiver Terminated

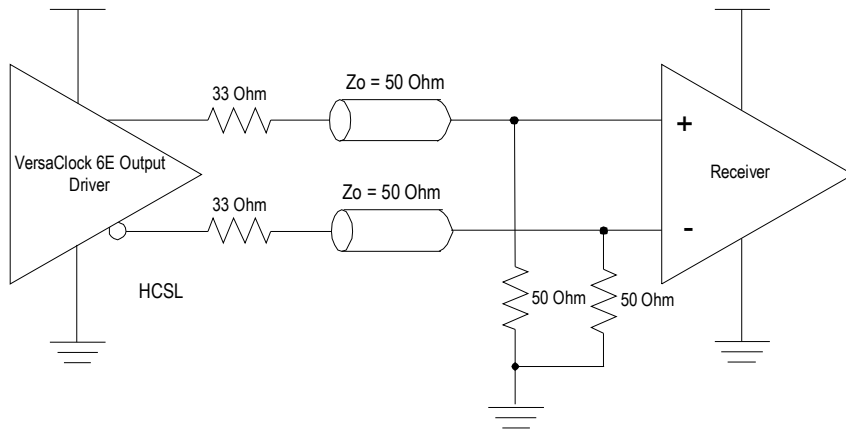
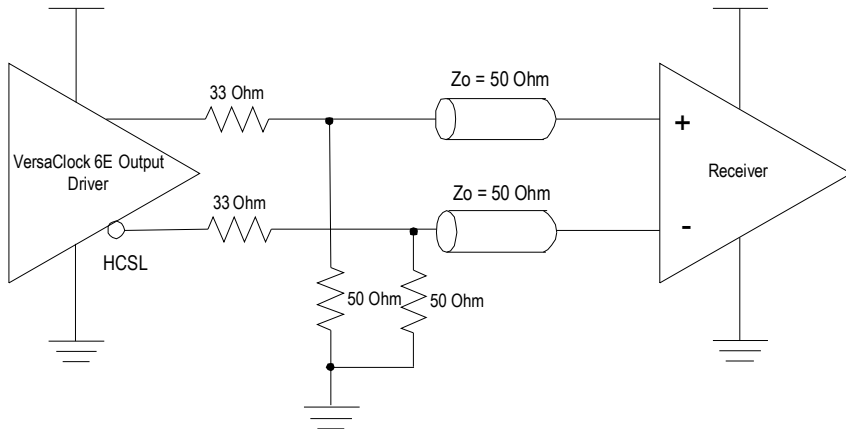

Figure 21. HCSL Source Terminated



LVC MOS Termination

Each output pair can be configured as a standalone CMOS or dual-CMOS output driver. CMOS driver termination example is shown below.

CMOS1 - Single CMOS active on OUTx pin.

CMOS2 - Single CMOS active on OUTxB pin.

CMOSD - Dual CMOS outputs active on both OUTx and OUTxB pins, 180 degrees out of phase.

CMOSX2 - Dual CMOS outputs active on both OUTx and OUTxB pins, in-phase.

Figure 22. LVC MOS Termination

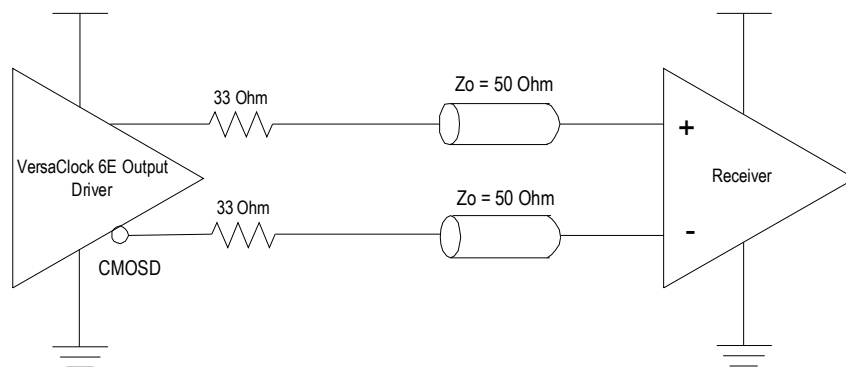

Package Outline Drawings

The package outline drawings are located at the end of this document and are accessible from the Renesas website (see [Ordering Information](#) for POD links). The package information is the most current data available and is subject to change without revision of this document.

Marking Diagram

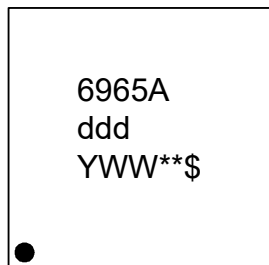

- Line 1: truncated part number.
- Line 2: “ddd” denotes dash code.
- Line 3:
 - “YWW” is the last digit of the year and week that the part was assembled.
 - “**” denotes sequential lot number.
 - “\$” denotes mark code.

Ordering Information

Orderable	Package	Carrier Type	Temperature Range
5P49V6965AdddNLGI	4 × 4 mm, 0.5mm pitch 24-VFQFPN	Tray	-40° to +85°C
5P49V6965AdddNLGI8	4 × 4 mm, 0.5mm pitch 24-VFQFPN	Tape and Reel	-40° to +85°C
5P49V6965A000NLGI	4 × 4 mm, 0.5mm pitch 24-VFQFPN	Tray	-40° to +85°C
5P49V6965A000NLGI8	4 × 4 mm, 0.5mm pitch 24-VFQFPN	Tape and Reel	-40° to +85°C

¹ “ddd” denotes factory programmed configurations based on required settings. Contact factory for factory programming.

² “000” denotes un-programmed parts for user customization.

Revision History

Revision Date	Description of Change
April 17, 2024	Updated 1.8V V_{OH} to $0.7 \times V_{DDO}$ from $0.5 \times V_{DDO}$ in Table 9 .
January 25, 2022	Updated descriptive text in Output – Single-ended or Differential Clock Terminations, LVDS Termination section.
July 6, 2021	<ul style="list-style-type: none"> ▪ Updated “non-standard termination” descriptive text in section LVDS Termination. ▪ Updated Package Outline Drawings section.
August 20, 2020	Updated the slew rate terminology in section Driving XIN/REF with a CMOS Driver .
September 18, 2019	<ul style="list-style-type: none"> ▪ Updated Absolute Maximum Ratings table. ▪ Updated PCI Express Jitter Performance tables (Table 17 and Table 18). ▪ Updated Electrical Characteristics tables (Table 9, Table 11, and Table 14).
June 19, 2019	<ul style="list-style-type: none"> ▪ PCIe specification updated. ▪ Added recommended power ramp time. ▪ Expanded spread spectrum value range. ▪ I2C tolerant voltage footnote changed to 3.3V. ▪ LVDS Termination section allows AC-coupling for LVDS signals.
August 31, 2018	Updated schematics for Driving XIN/REF with a CMOS Driver and Driving XIN with an LVPECL Driver .
March 15, 2018	<ul style="list-style-type: none"> ▪ Updated absolute maximum ratings for supply voltage to 3.6V. ▪ Updated typical and maximum values in Current Consumption table. ▪ Minor updates to AC Timing Characteristics, Electrical Characteristics – CMOS Outputs, and Electrical Characteristics – LVDS Outputs tables.
November 6, 2017	Initial release.

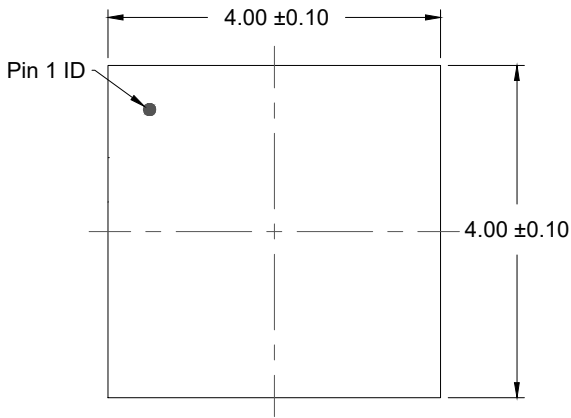

TOP VIEW

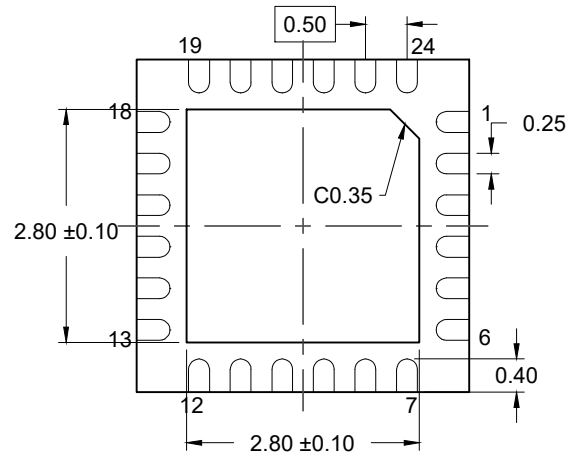

BOTTOM VIEW

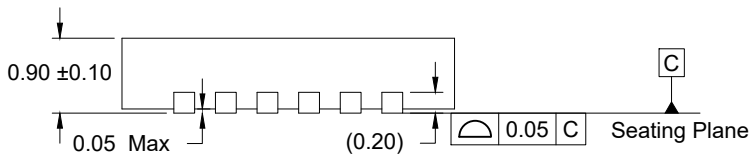

SIDE VIEW

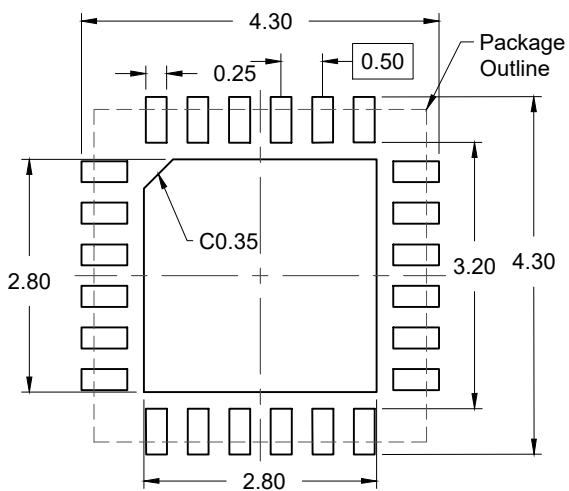

RECOMMENDED LAND PATTERN
(PCB Top View, NSMD Design)

NOTES:

1. JEDEC compatible.
2. All dimensions are in mm and angles are in degrees.
3. Use ± 0.05 mm for the non-toleranced dimensions.
4. Numbers in () are for references only.

