

Contents

1. Introduction.....	2
2. Switch Fabric and Receiver Signal Polarity Inversion	2
2.1 Meeting Processing Requirements via the Switch Fabric and Post-CORDIC Polarity Inversion.....	3
2.1.1 Switch Fabric.....	3
2.1.2 Polarity Inversion	3
2.1.3 Cordic and Spatial Angle Expansion	3
3. Linear Mode Operation.....	5
3.1 SPA Characteristics.....	5
3.2 Configuration Examples using the ZMID5203 Inductive Arc Application Module	6
3.2.1 Output Mode Selection	6
3.2.2 Definition of Target Movements.....	7
3.2.3 SPA Characteristic Graphs.....	8
4. Glossary	10
5. Revision History.....	10

List of Figures

Figure 1. Functional Block Diagram of the Switch Fabric and Polarity Inversion.....	2
Figure 2. Expansion in Rectangular Coordinates	3
Figure 3. Expansion in Polar Coordinates	4
Figure 4. GUI Configure Tab	5
Figure 5. EEPROM Memory Values – ZMID5203 Example for the Linear Output Mode Settings	6
Figure 6. Example Target Start and End Positions for the ZMID520xMARC13003 Arc Application Module.....	7
Figure 7. SPA Monotonic Characteristic.....	8
Figure 8. SPA with Non-monotonic Characteristic (with “Jump”).....	9

List of Tables

Table 1. Combinations Permitted for Configuration Bits in Register 09 _{HEX}	6
Table 2. Valid Configuration Bits Combinations with Resulting Slope.....	9

1. Introduction

This document describes the procedures for configuring IDT's ZMID520x Inductive Position Sensor ICs as needed to achieve a monotonic output characteristic over the target position swing when operating in Linear Output Mode. This includes instructions for setting up the switch fabric, which routes the signal from the coils to the next signal processing stage, and for setting up the receiver signal polarity in order to start measurements with the device in user applications using the Linear Output Mode.

This application note provides an explanation, from the trigonometric point of view, of the application of the available settings (section 2) and then illustrates the impact of the settings on the ZMID520x output behavior (section 3).

The steps provided here are required when configuring a new device in a user application. These procedures can also be applied to any of the ZMID520x application modules provided by IDT if default settings must be modified.

Recommendation: Read the following documents before using this document.

- ZMID520x Datasheet: <https://www.idt.com/document/dst/zmid520x-datasheet>
- ZMID520x User Guide for Getting Started: <https://www.idt.com/document/man/zmid520x-user-guide-getting-started>
- ZMID520x Evaluation Kit User Manual: <https://www.idt.com/document/man/zmid520x-evaluation-kit-user-manual-application-modules>

2. Switch Fabric and Receiver Signal Polarity Inversion

This section provides a basic description of the ZMID520x switch fabric and receiver signal polarity inversion functionality.

The input signal generated by the coils (R1 and R2) is sampled by the internal ADC and fed to the switch fabric. The switch fabric allows routing the sampled signal to the Xsine and Ycosine internal lines (Figure 1). The switch fabric allows swapping either the amplitude or the polarity of each input (R1 input after ADC, R2 input after ADC).

The ZMID520x offers design freedom via internal routing and differential input signal polarity swapping features so that the PCB can be designed with the R1 and R2 coil terminals connected to the ZMID520x's receiver input pins with either polarity.

For applications using the ZMID520x in the Linear Output Mode, these functionalities allow the user to achieve a monotonic output characteristic over the target position swing (start to end of travel range and vice versa). Signals configured with the "swap_rc_pol" and "swap_rc_amp" bits control this functionality as shown in Figure 1. See section 3.1 regarding constraints on the combinations of these bits. The "invppr1/2" signal is used for setting the CORDIC angle in the proper quadrant (polar coordinates; see section 2.1.3).

Figure 1. Functional Block Diagram of the Switch Fabric and Polarity Inversion

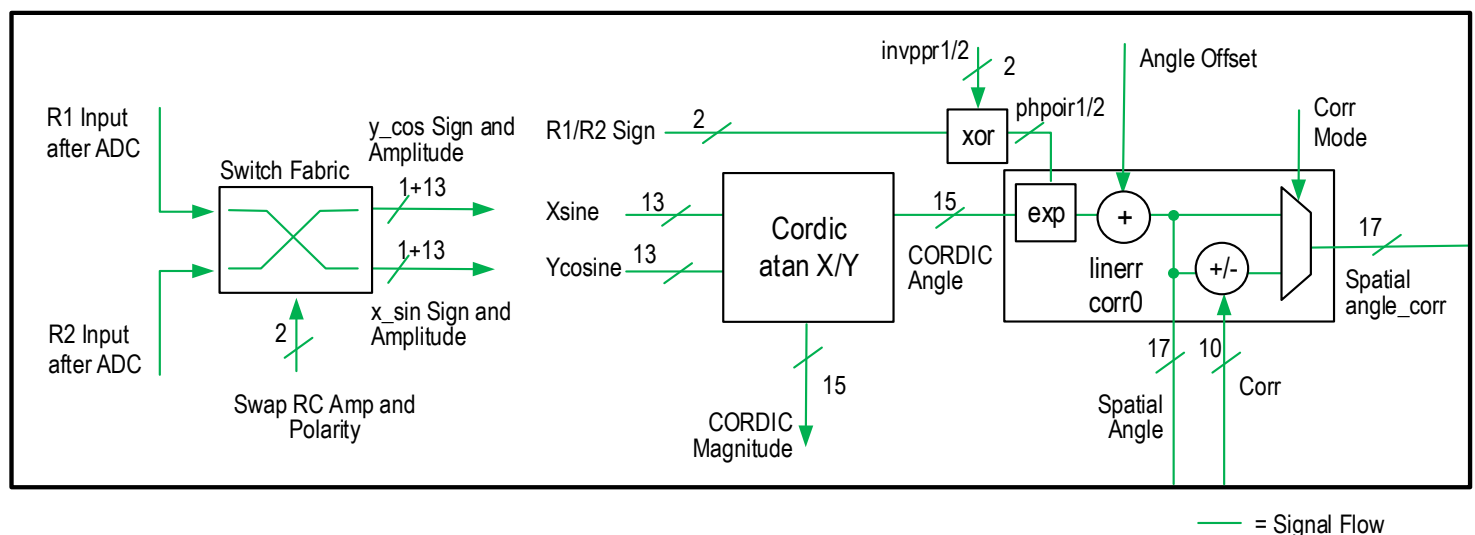

2.1 Meeting Processing Requirements via the Switch Fabric and Post-CORDIC Polarity Inversion

2.1.1 Switch Fabric

The switch fabric defines which receivers are the numerator and denominator for the atan (CORDIC) calculation: atan (R1/R2) or atan(R2/R1).

2.1.2 Polarity Inversion

The individual inversion of the receiver signal polarity allows varying the expansion of the spatial angle (SPA) from a 0 to 90° range (output of the CORDIC block) to a 0 to 360° range.

Three different scenarios are possible:

- Denominator of the atan is sign inverted: The output has a 90° shift.
- Inverted sign of both receivers: This corresponds to a shift of 180° in the coordinate system.
- Numerator of the atan is sign inverted: The output has a 270° shift.

2.1.3 Cordic and Spatial Angle Expansion

The CORDIC (Coordinate to Rotation Digital Computer) block converts rectangular coordinates (sin, cos) into polar coordinates (angle, magnitude). A graphical representation of the CORDIC operation is provided in Figure 2 and Figure 3.

Figure 2. Expansion in Rectangular Coordinates

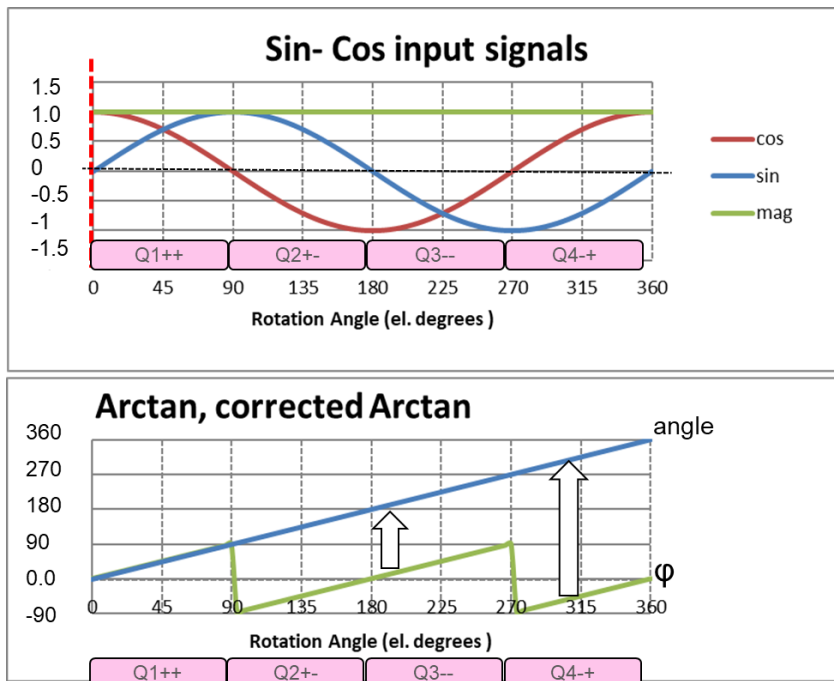
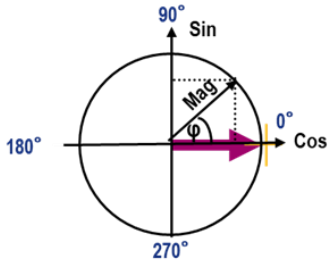

Figure 3. Expansion in Polar Coordinates



$$\tan(\varphi) = \frac{a \times \sin(\varphi)}{a \times \cos(\varphi)}$$

$$\arctan\left(\frac{a \times \sin(\varphi)}{a \times \cos(\varphi)}\right) = \arctan(\tan(\varphi)) = \varphi$$

Q1: angle = φ

Q2,Q3: angle = $\varphi + 180$

Q4: angle = $\varphi + 360$

$$\text{Mag} = \sqrt{(a \times \sin(\varphi))^2 + (a \times \cos(\varphi))^2}$$

3. Linear Mode Operation

For an overview on the Linear Mode operation, refer to the following documents (see section 1 for document links):

- ZMID520x Evaluation Kit User Manual
- ZMID520x-User-Guide-Getting-Started

3.1 SPA Characteristics

The SPA is the angle value calculated by the CORDIC processor block, expanded to a 360° range (see Figure 2). This is the angle value before the calibration and linear error correction. To achieve a monotonic characteristic for the sensor output, proper selections must be made for the “swap_rc_pol” and “swap_rc_amp” bits in register 09_{HEX} and the “invppr1/2” bit in register 09_{HEX}.

An example is provided below using the ZMID5203 Inductive Arc Application Module described in the ZMID520xMARC13003 Arc Application Module User Manual available at the following link: <https://www.idt.com/document/man/zmid520xmarc-application-module-user-manual>

Figure 4 shows the GUI tab with the configuration bits to be used in the configuration.

Figure 4. GUI Configure Tab

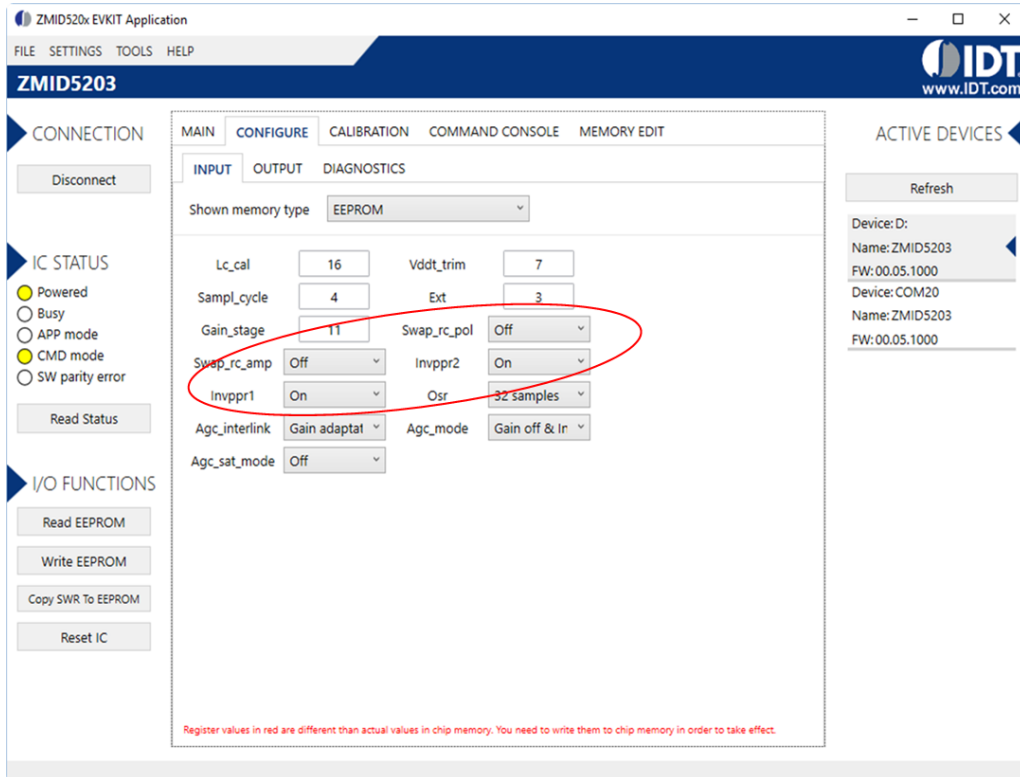

For application purposes, the “Swap_rc_pol” and “Swap_rc_amp” entry fields must have the same values: either both “On” or both “Off”; i.e., bits set to 00_{BIN} or 11_{BIN} in register 09_{HEX} (see Table 1). The remaining combinations are intended for test purposes only. The combinations permitted for the “swap_rc_pol” and “swap_rc_amp” bits and the “invppr1/2” bits are listed in the Table 1.

Table 1. Combinations Permitted for Configuration Bits in Register 09_{HEX}

Configuration #	swap_rc_pol (Bit 3)	swap_rc_amp (Bit 2)	invppr2 (Bit 1)	invppr1 (Bit 0)
1	off	off	off	off
2	off	off	on	off
3	off	off	off	on
4	off	off	on	on
5	on	on	off	off
6	on	on	on	off
7	on	on	off	on
8	on	on	on	on

3.2 Configuration Examples using the ZMID5203 Inductive Arc Application Module

3.2.1 Output Mode Selection

Use the Linear Output Mode. Set the following register values as shown in Figure 5: register 00_{HEX} = 2400_{HEX}; register 01_{HEX} = 0400_{HEX}; and registers 02_{HEX} through 09_{HEX} = 0000_{HEX}.

Figure 5. EEPROM Memory Values – ZMID5203 Example for the Linear Output Mode Settings

Set these standard values for registers 00_{HEX} to 09_{HEX}. Remaining register values might differ.

Write new values to the ZMID520x EEPROM.

EEPROM	0	1	2	3	4	5	6	7
0h	2400	0400	0000	0000	0000	0000	0000	0000
8h	0000	0000	0803	B107	0836	0255	BFFF	0000
10h	0000	00C2						

SWR	0	1	2	3	4	5	6	7
0h	2400	0400	0000	0000	0000	0000	0000	0000
8h	0000	0000	0803	B107	0836	0255	BFFF	
10h		00C2		0360	000F	0011	3D69	002D
18h	9EB4	9EB4	9EB4	0001				

3.2.2 Definition of Target Movements

Figure 6 identifies the start and the end positions for the target movement. The definitions of the start and the end positions are arbitrary, and the two points can be swapped.

Figure 6. Example Target Start and End Positions for the ZMID520xMARC13003 Arc Application Module

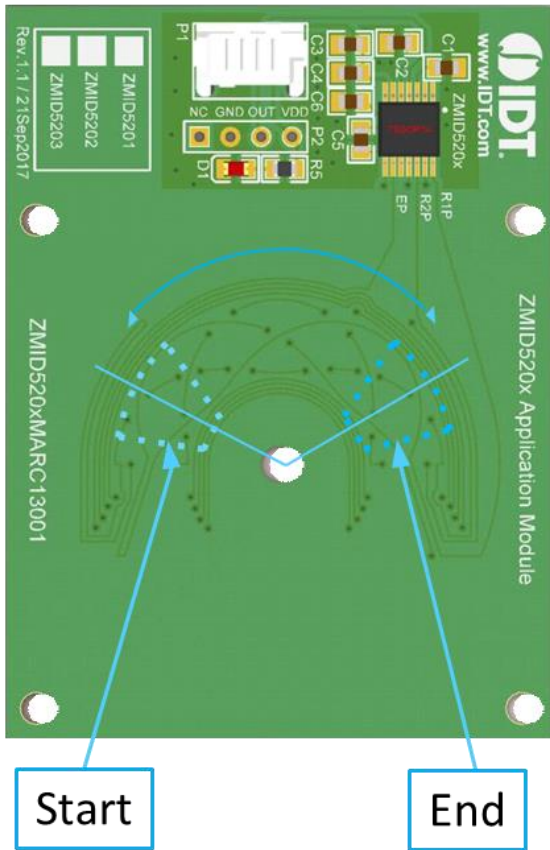

3.2.3 SPA Characteristic Graphs

Figure 7 and Figure 8 show the effects of the GUI settings for the configuration bits per configurations 7 and 8 respectively as given in Table 1.

Figure 7. SPA Monotonic Characteristic



Figure 8. SPA with Non-monotonic Characteristic (with “Jump”)



In both cases the target has been moved from the start to the end position as per Figure 6.

Figure 8 shows a SPA (and hence POS1) that does not have a monotonic characteristic (note the “jump”), which prevents acquiring the actual target position. In Figure 7, the SPA (hence POS1) has a monotonic characteristic allowing the identification the position of the target.

When the target moves from the start to end positions (see Figure 6), a complete analysis of the SPA characteristic for each configuration combination listed in Table 1 gives the results summarized in Table 2, which includes the output slope for POS1: positive, negative, or NA (with “jump”). In Table 2, the pink shading indicates the two configuration bits sets that result in a monotonic output: configurations #2 and #4. The abbreviation “n.a.” in the “Slope” column indicates that the slope does not have a constant sign.

Table 2. Valid Configuration Bits Combinations with Resulting Slope

Config #	swap_rc_pol	swap_rc_amp	invppr1	invppr2	Slope Sign
1	off	off	off	off	n.a.
2	off	off	off	on	positive
3	off	off	on	off	n.a.
4	off	off	on	on	negative
5	on	on	off	off	n.a.
6	on	on	off	on	n.a.
7	on	on	on	off	n.a.
8	on	on	on	on	n.a.

Configuration #2 allows the user to have a positive output slope moving the target from the start position to the end position. Configuration #4 has a negative output for the same target movement.

These considerations have general validity and apply to both linear and arc sensors when Linear Output Mode is selected.

4. Glossary

Acronym	Definition
ADC	Analog Digital Converter
SPA	Spatial Angle (register)
POS1	Position 1 (register)

5. Revision History

Revision Date	Description of Change
March 7, 2019	Initial release.

IMPORTANT NOTICE AND DISCLAIMER

RENESAS ELECTRONICS CORPORATION AND ITS SUBSIDIARIES (“RENESAS”) PROVIDES TECHNICAL SPECIFICATIONS AND RELIABILITY DATA (INCLUDING DATASHEETS), DESIGN RESOURCES (INCLUDING REFERENCE DESIGNS), APPLICATION OR OTHER DESIGN ADVICE, WEB TOOLS, SAFETY INFORMATION, AND OTHER RESOURCES “AS IS” AND WITH ALL FAULTS, AND DISCLAIMS ALL WARRANTIES, EXPRESS OR IMPLIED, INCLUDING, WITHOUT LIMITATION, ANY IMPLIED WARRANTIES OF MERCHANTABILITY, FITNESS FOR A PARTICULAR PURPOSE, OR NON-INFRINGEMENT OF THIRD-PARTY INTELLECTUAL PROPERTY RIGHTS.

These resources are intended for developers who are designing with Renesas products. You are solely responsible for (1) selecting the appropriate products for your application, (2) designing, validating, and testing your application, and (3) ensuring your application meets applicable standards, and any other safety, security, or other requirements. These resources are subject to change without notice. Renesas grants you permission to use these resources only to develop an application that uses Renesas products. Other reproduction or use of these resources is strictly prohibited. No license is granted to any other Renesas intellectual property or to any third-party intellectual property. Renesas disclaims responsibility for, and you will fully indemnify Renesas and its representatives against, any claims, damages, costs, losses, or liabilities arising from your use of these resources. Renesas' products are provided only subject to Renesas' Terms and Conditions of Sale or other applicable terms agreed to in writing. No use of any Renesas resources expands or otherwise alters any applicable warranties or warranty disclaimers for these products.

(Disclaimer Rev.1.01)

Corporate Headquarters

TOYOSU FORESIA, 3-2-24 Toyosu,
Koto-ku, Tokyo 135-0061, Japan
www.renesas.com

Trademarks

Renesas and the Renesas logo are trademarks of Renesas Electronics Corporation. All trademarks and registered trademarks are the property of their respective owners.

Contact Information

For further information on a product, technology, the most up-to-date version of a document, or your nearest sales office, please visit www.renesas.com/contact-us/.