

RA2E3 Group

Software Project Migration Example to RA2E3 from RA2E1

Introduction

This application note describes how to migrate an existing project for the RA2E1 MCU using Renesas Flexible Software Package (FSP) to the RA2E3 MCU.

Please obtain the sample project “[r01an7156xx0100-ra2e1-to-ra2e3-software-migration.zip](#)” from our website in advance.

Required Resources

Hardware

- Renesas RA Kit FPB-RA2E3 (for RA2E3 MCU (Device: R7FA2E3073CFL))
- USB-TTL Serial Converter Cable
- Jumper wires

Development Tools and Software

- e² studio IDE version 2023-10
- Renesas Flexible Software Package (FSP) version v5.0.0
- GCC ARM Embedded Toolchain version 12.2.1.20230214
- SEGGER J-Link RTT viewer version 7.92j
- Terminal Software Tera Term

Refer to the Website and Support section to find the link to the Renesas FSP GitHub web site and find the package installer `setup_fsp_v5_0_0_e2s_v2023-10.exe/.AppImage` there. Items except Tera Term can be installed using the installer.

Contents

1. Project Migration Flow	3
2. System Overview of Sample Project	4
2.1 Project Summary	4
2.2 Hardware configuration	4
3. Example of Project Migration	5
3.1 Import migration source project.....	5
3.2 Change Device	6
3.3 Edit Pin Configuration.....	7
3.4 Edit Stacks.....	8
3.5 Edit BSP and Clocks	9
3.6 Generate Project Content.....	9
3.7 Edit user application code	10
3.8 Build.....	10
4. Check the operation of the sample project.....	10
4.1 Hardware Setting.....	10
4.2 Download the program to the RA2E3 MCU	11
4.3 J-Link RTT Viewer Connection.....	12
4.4 Tera Term Connection	13
4.5 Running the project	14
5. Website and Support	15
Revision History.....	16

1. Project Migration Flow

This chapter describes the general migration flow for a project using FSP.

For hardware differences between RA2E1 MCU and RA2E3 MCU, refer to **Migration Guide from RA2E1 to RA2E3 (R01AN7011)** and consider the hardware configuration in advance.

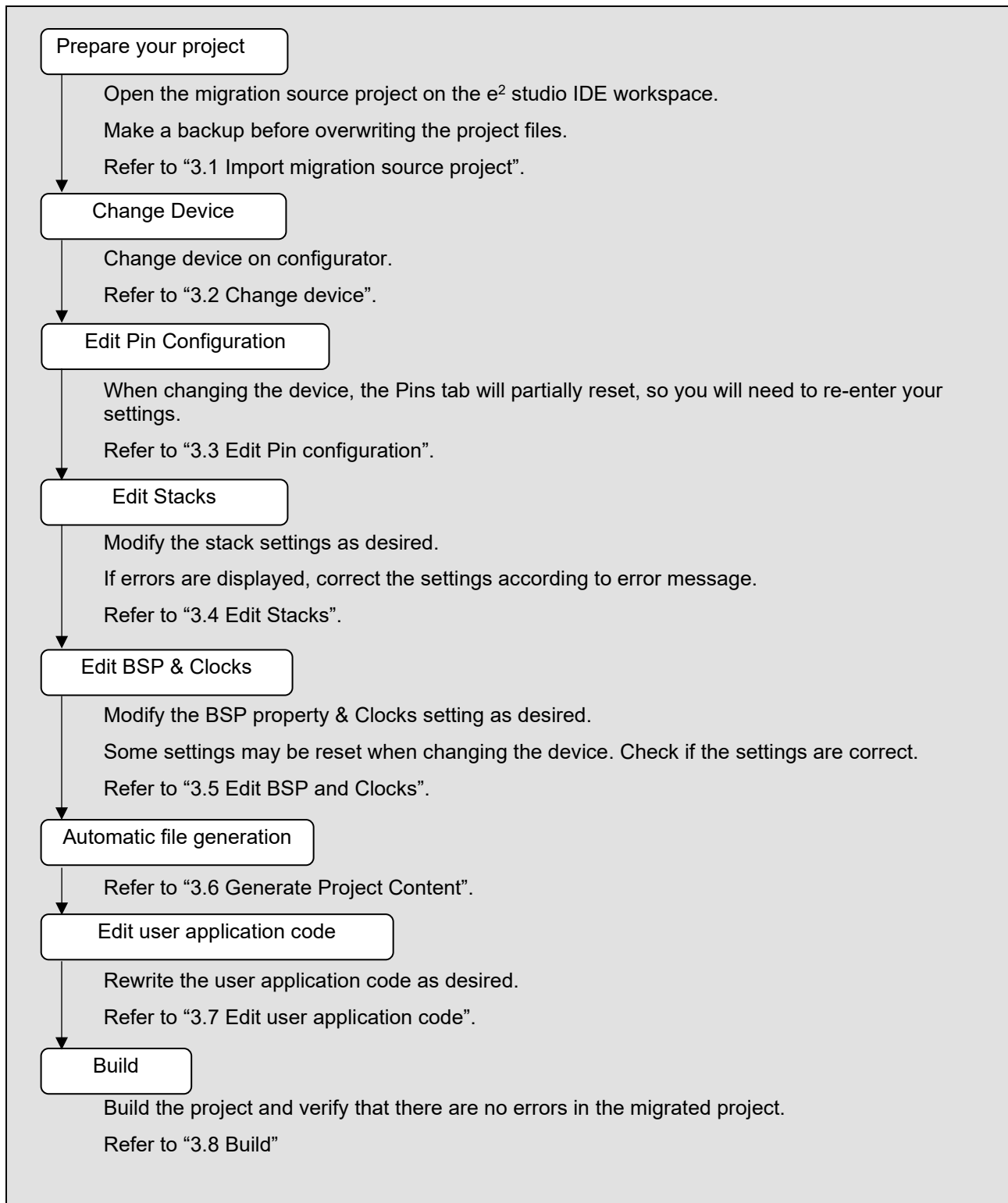

Figure 1. Migration Flow

2. System Overview of Sample Project

2.1 Project Summary

This section provides an operation overview of the pre-migration project and the post-migration project used in this application note. This program is created based on the SCI UART project of RA family Example Project published on our website.

The behavior of the application program before and after migration is the same. Via UART communication, the duty cycle of the PWM, which controls the LED brightness is adjusted from the terminal software Tera Term.

The flow of the project is shown below:

- ① Wait for data to be entered from Tera Term.
- ② When a number 1~100 is received, the brightness of the LED will be changed according to the value.
- ③ Send a message requesting the next data to Tera Term, and return to ①.

Note: if data other than number 1~100 is received from Tera Term, the LED brightness will not change. Send a message requesting current data to Tera Term, and return to ①.

Note: If a communication error occurs, the program will stop. In that case, reset the MCU.

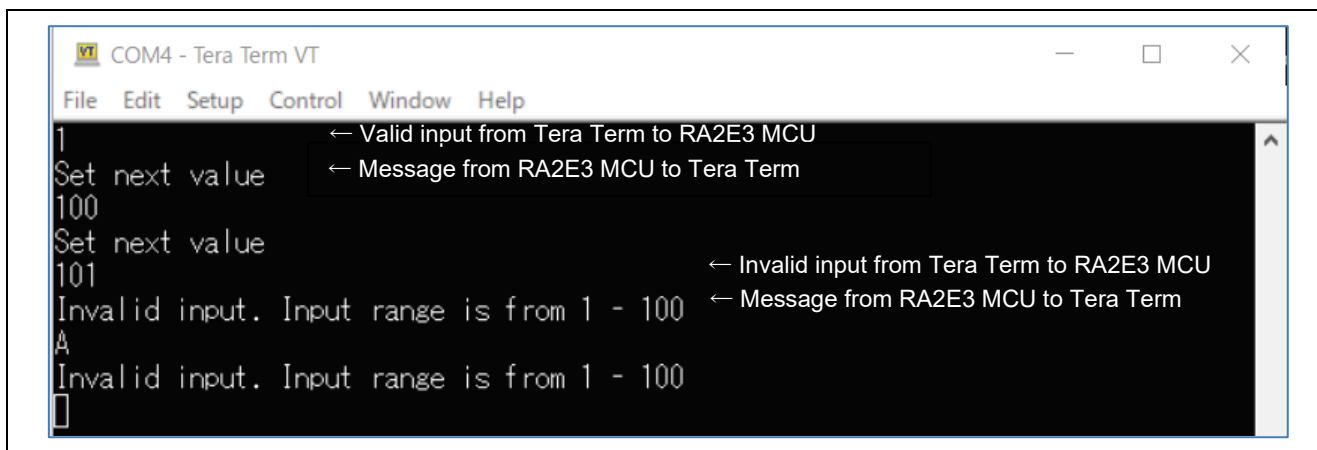

Figure 2. Communication between RA2E3 MCU and Tera Term

2.2 Hardware configuration

Table 1 shows the hardware configuration for this project.

Table 1. Hardware Configuration

	Pre-migration project	Post-migration project
MCU Group	RA2E1	RA2E3
Device package	R7FA2E1A92DFM · LQFP64pin	R7FA2E3073CFL · LQFP48pin
External oscillator (MOSC SOSC)	Not used	Not used
GPT channel Output terminal	GPT channel 0 GTIOC0B : P212	GPT channel 0 GTIOC0B : P212
SCI channel Output/ Input terminal	SCI channel 0 RXD : P410 · TXD : P411	SCI channel 0 RXD : P100 · TXD : P101

In the pre-migration project, SCI0 pins P410 and P411 are used for UART communication. These pins are not present on the destination device, the RA2E3 MCU. Therefore, in this project, the RXD pin is changed to P100 and the TXD pin is changed to P101 when migrating the project.

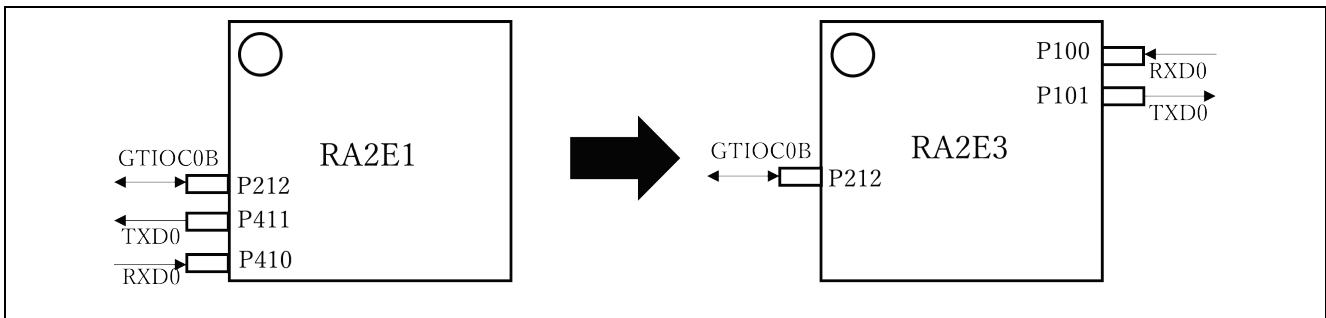

Figure 3. Pin Composition

3. Example of Project Migration

3.1 Import Migration Source Project

Import the sample project “r01an7156xx0100-ra2e1-to-ra2e3-software-migration.zip” into your destination workspace.

1. Start the e² studio IDE.
 Select **File**> **Import** to display the project import screen.
 Select **General** > **Existing Projects into Workspace**, click **Next**, and proceed to the next screen.
2. Check **Select archive file**, select the downloaded sample project from **Browse...**, and click **Finish**.

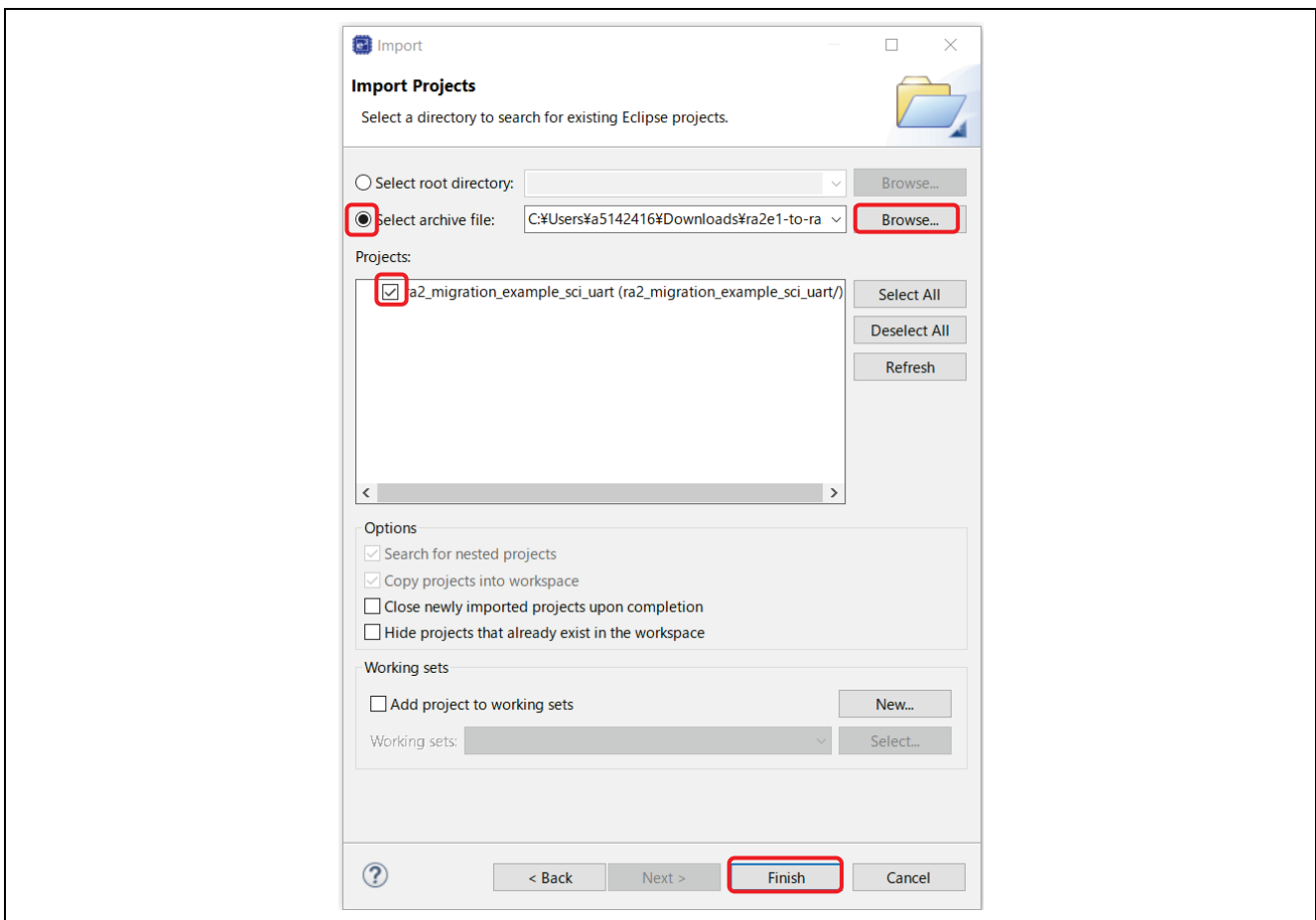

Figure 4. Importing the Project

3. Verify that the sample project has been imported into your workspace and is visible in the Project Explorer.

3.2 Change Device

Change the device selection to RA2E3 MCU.

1. Expand the project and launch the configurator by double-clicking "configuration.xml".

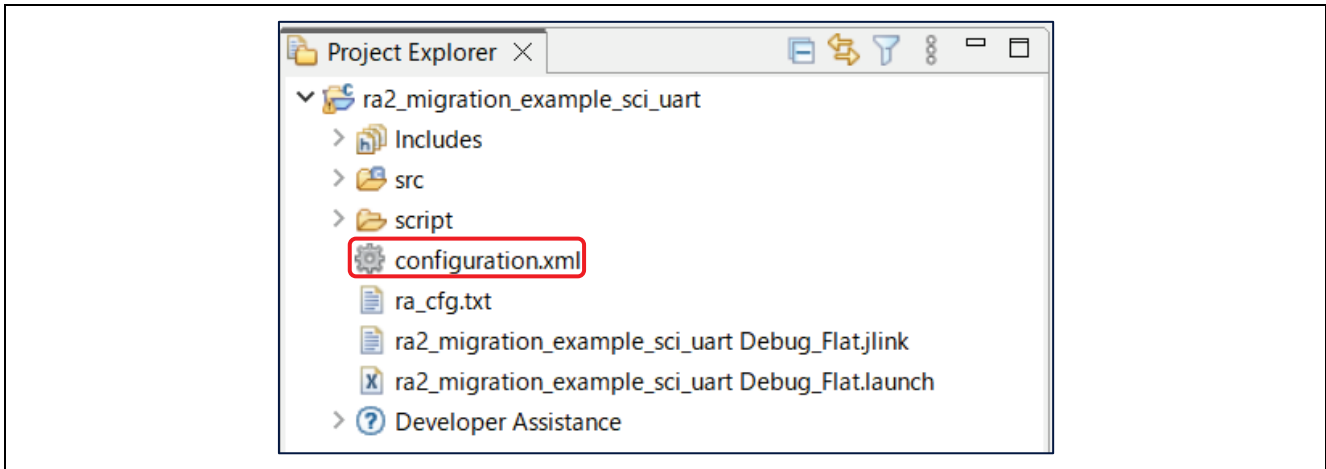

Figure 5. Project Deployment

2. Select the BSP tab and change the Device to RA2E3 MCU.
 Click ... to select the product model number from the device group and the number of pins.
 Here, select R7FA2E3073CFL from RA2 > RA2E3 > RA2E3 – 48 Pin and press OK.

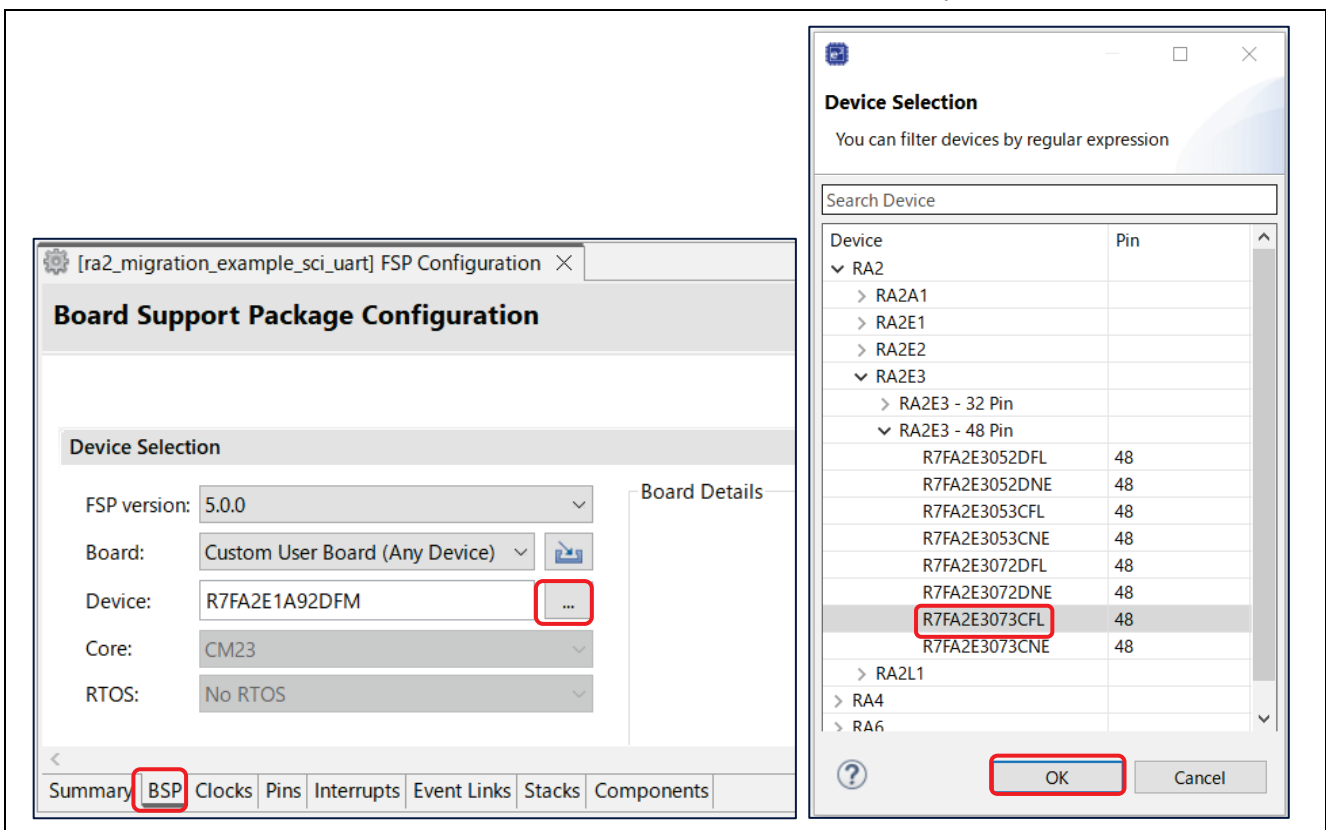

Figure 6. Changing the Device

3.3 Edit Pin Configuration

Modify the pin configuration on the Pins tab depending on the hardware configuration change. In this project, a new pin configuration `R7FA2E3073CFL.pincfg` will be enabled and the pins for the MCU are assigned.

1. Select the Pins tab.

Even after changing the device, a pin configuration `R7FA2E1A92DFM.pincfg` of the source project is selected.

Uncheck **Generate data** to switch to the pin configuration `R7FA2E3073CFL.pincfg`.

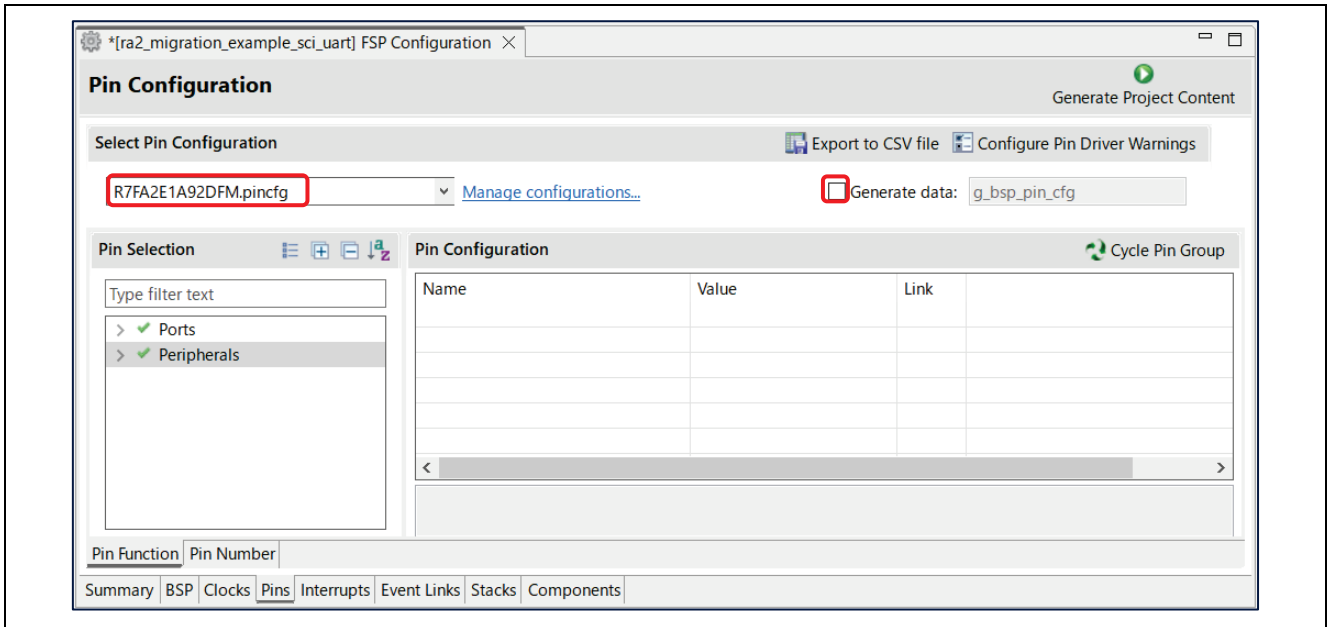

Figure 7. Changing the Pin Configuration (1)

2. Select the pin configuration `R7FA2E3073CFL.pincfg` from the pull-down list.

Check **Generate data** and enter a data variable name “`g_bsp_pin_cfg`” of the pin configuration data in the text field on the right.

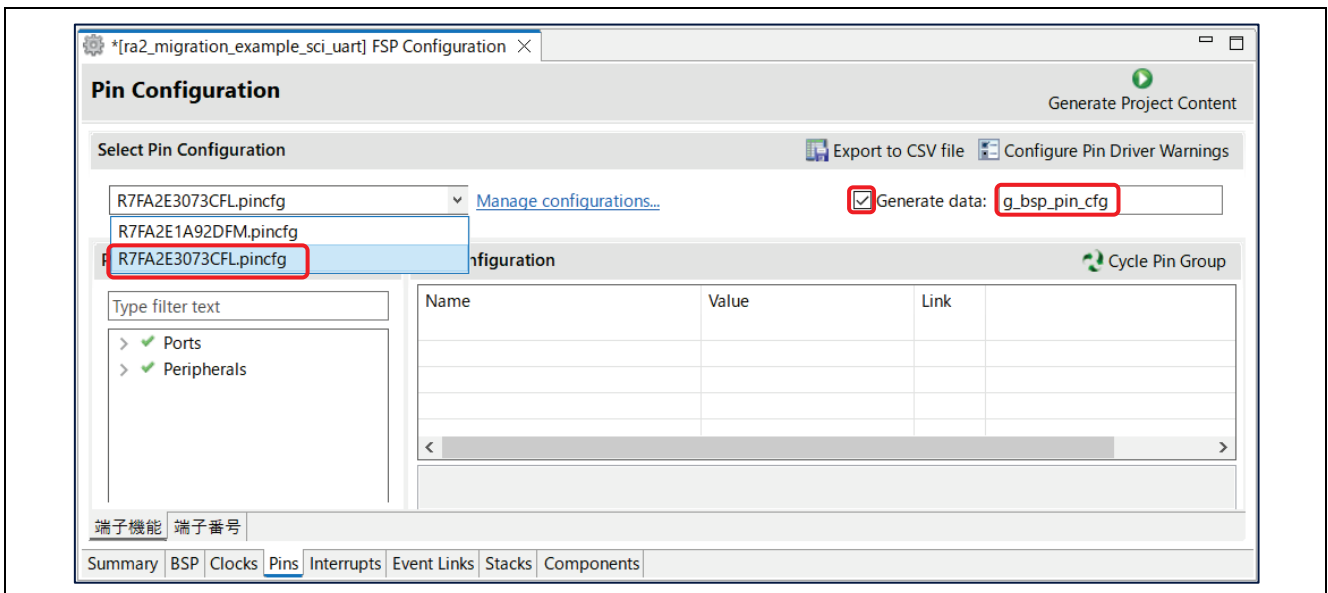

Figure 8. Changing the Pin Configuration (2)

3. Edit the pin configuration of the SCI module.
 Click **Peripherals > Connectivity:SCI** and select **SCI0**.
 Change the Operation Mode to Asynchronous UART.
 After changing the mode, assign P100 to RXD0 and P101 to TXD0.

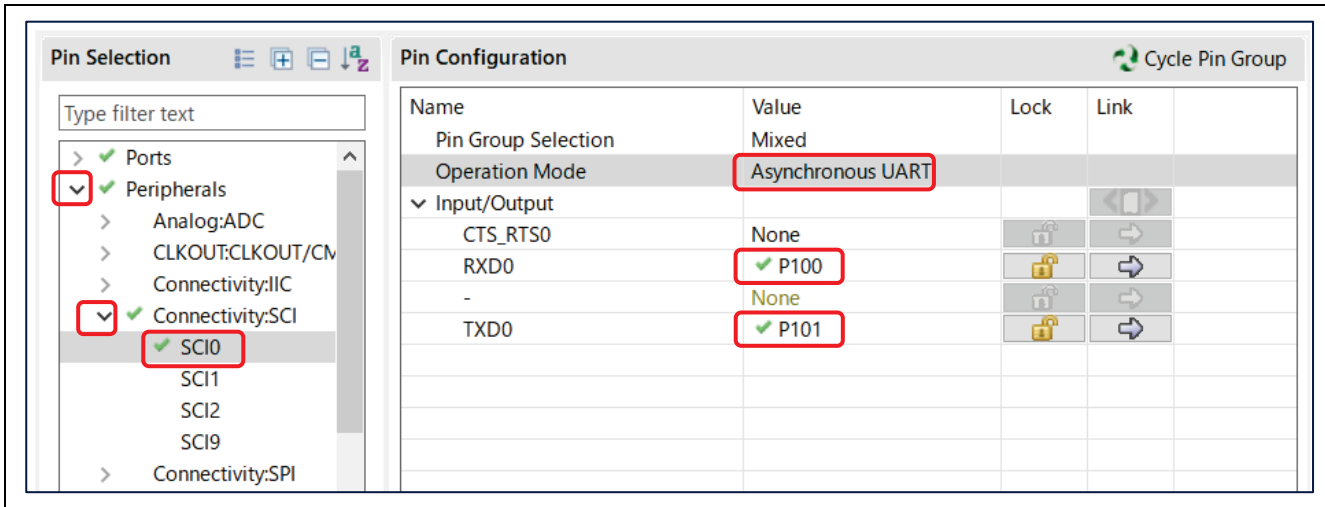

Figure 9. SCI Module Pin Setting

4. Edit the pin configuration of the GPT module.
 Click **Peripherals > Timers:GPT** and select **GPT0**.
 Change the Operation Mode to GTIOCA or GTIOCB and assign P212 to GTIOC0B.

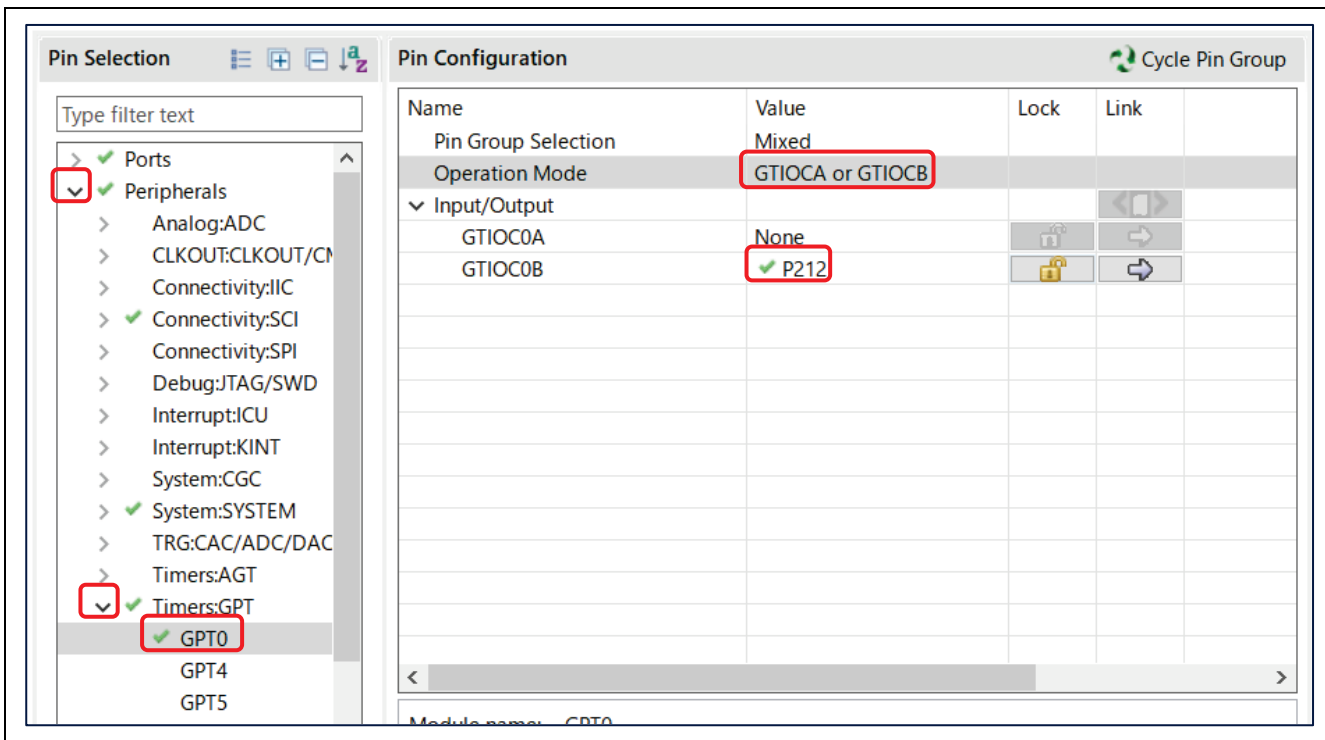

Figure 10. GPT Module Pin Setting

3.4 Edit Stacks

Select the Stacks tab and verify that no errors have occurred.

This project does not edit stack setting.

3.5 Edit BSP and Clocks

Some **BSP** property & **Clocks** settings may be reset when changing the device.

Please verify that these settings are set up as expected.

1. Select the **BSP** tab and verify its properties.

This project has no difference before and after changing the device. So, no need to edit the BSP properties.

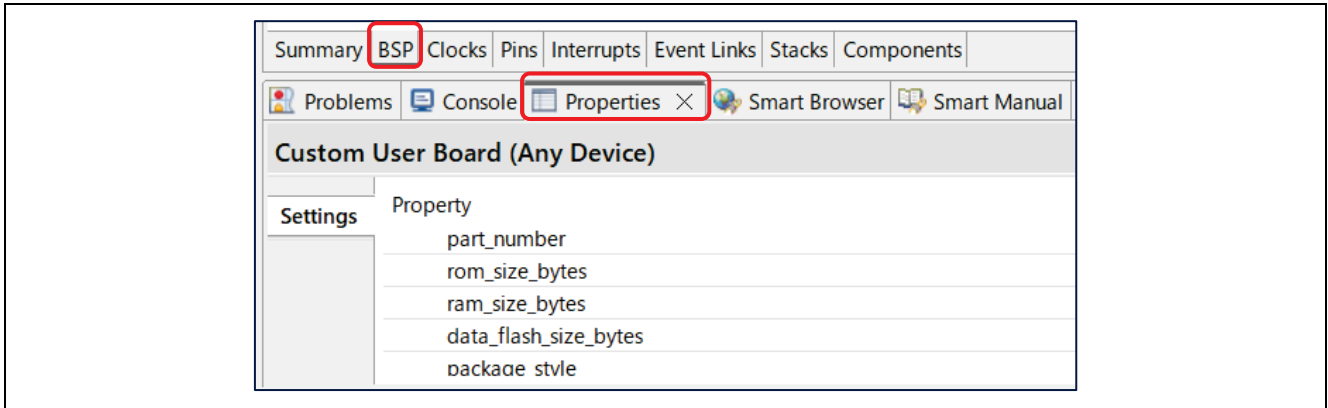

Figure 11. BSP Property Setting

2. Select and verify the **Clocks** tab.

This project has no difference before and after changing the device. So, no need to edit the clocks.

3.6 Generate Project Content

1. Save your changes and click **Generate Project Content**.

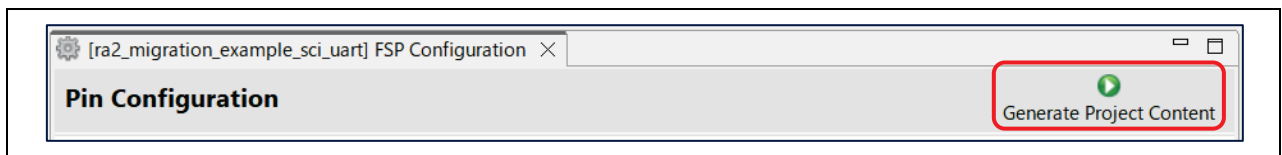

Figure 12. Automatic File Generation

2. Confirm that the following four directories have been created in the project.

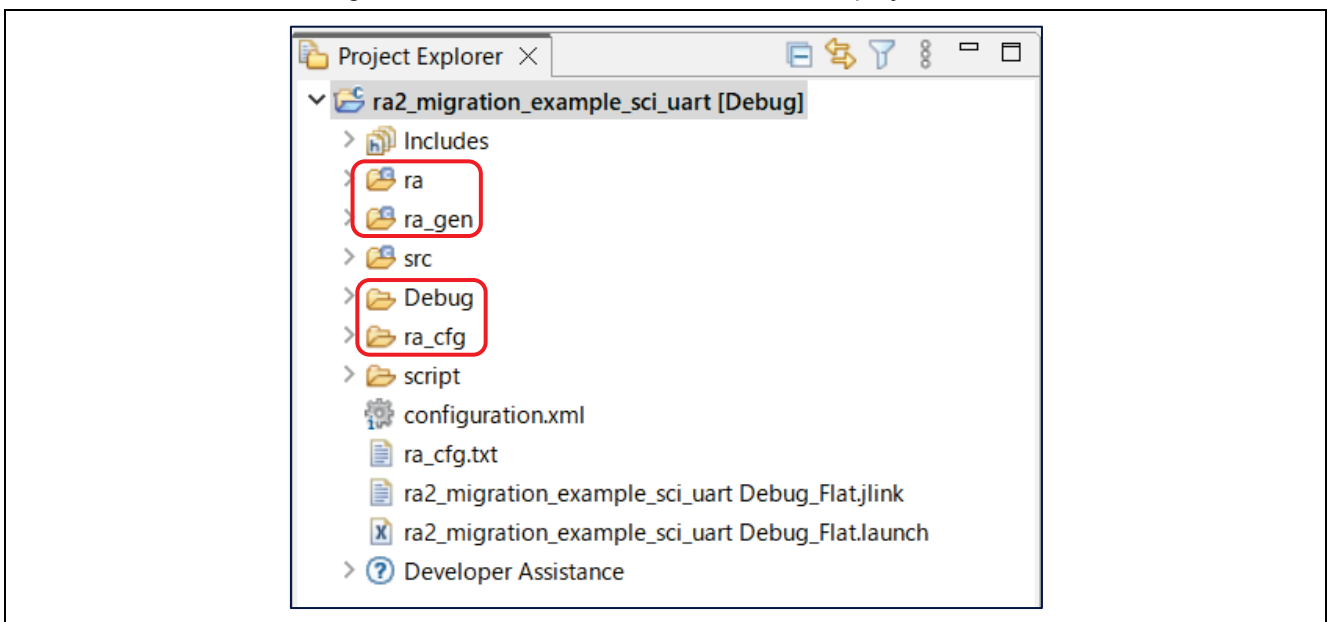



Figure 13. Generated Files

3.7 Edit User Application Code

There is no need to edit user application code in this project.

3.8 Build

In the Project Explorer, right-click on the project name and press **Build Project**.

Alternatively, you can also build from the build icon  on the top left of the toolbar.

Verify that the build is complete and there are no errors.

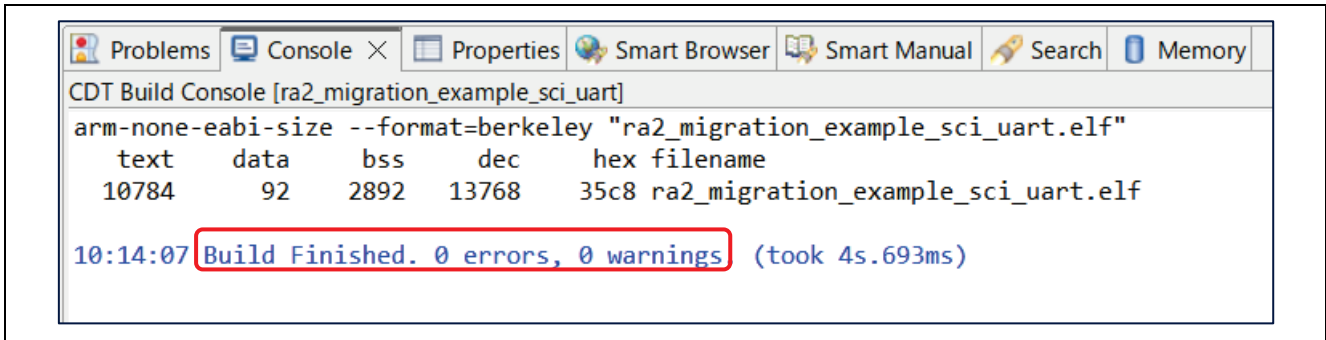

Figure 14. Project Build Results

4. Check the Operation of the Sample Project

4.1 Hardware Setting

1. Connect with jumper wires as shown below:
 - A. RXD P100 (FPB-RA2E3 Pmod1-3) <---> TXD Pin of USB-TTL Serial Converter Cable
 - B. TXD P101 (FPB-RA2E3 Pmod1-2) <---> RXD Pin of USB-TTL Serial Converter Cable
 - C. GND (FPB-RA2E3) <---> GND Pin of USB-TTL Serial Converter Cable
 - D. GTIOC0B P212 (FPB-RA2E3 Pmod2-2) <---> P914(FPB-RA2E3 Pmod1-9, connected to onboard LED2)
2. Connect the USB-TTL Serial Converter Cable to the host PC.

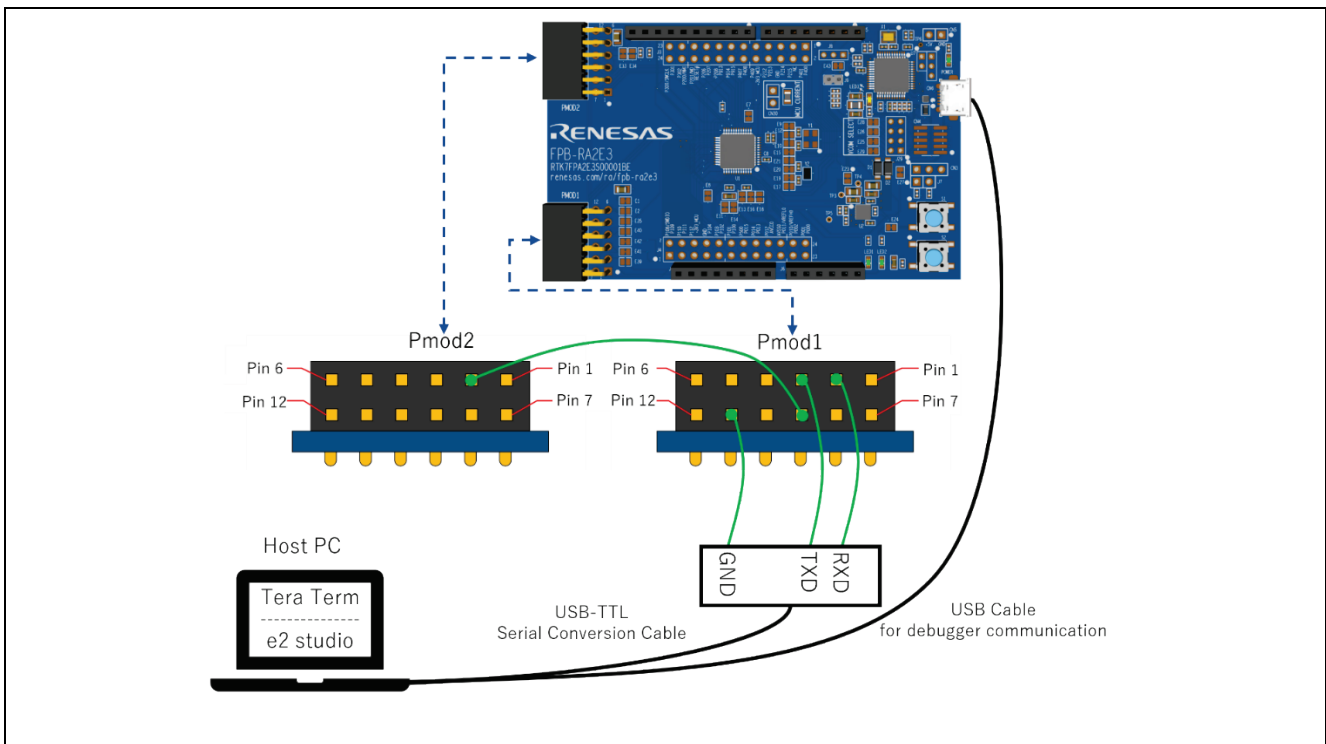

Figure 15. Hardware Setting

4.2 Download the Program to the RA2E3 MCU

1. Make sure FPB-RA2E3 kit is connected to the host PC with a USB cable.
2. In the Project Explorer on the e² studio IDE, right-click the project name and select **Debug As > Debug Configurations**.

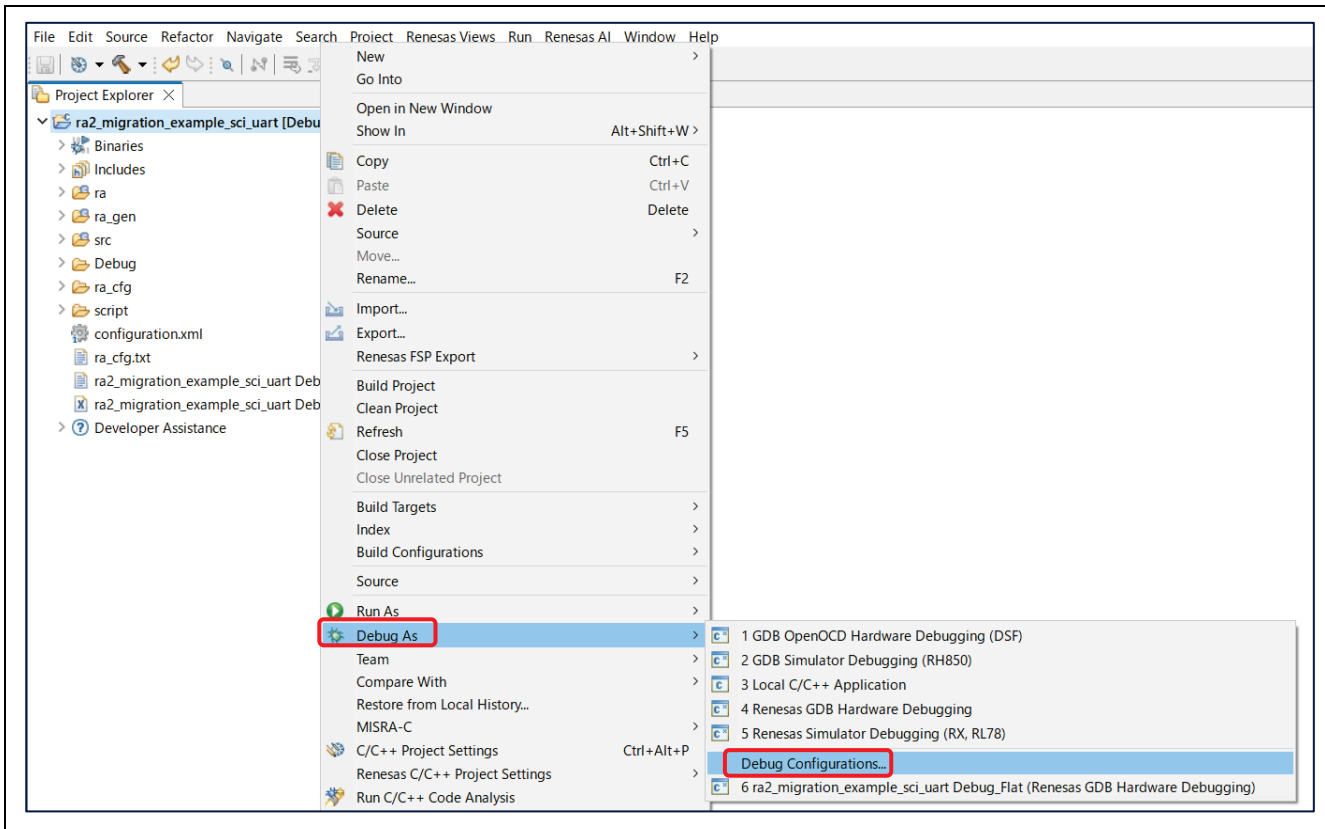

Figure 16. Project Download (1)

3. Open **Renesas GDB Hardware Debugging** and select the migrated project. Select Debugger, verify that the Debug hardware is J-Link ARM and the Target Device is R7FA2E307, then press Debug.

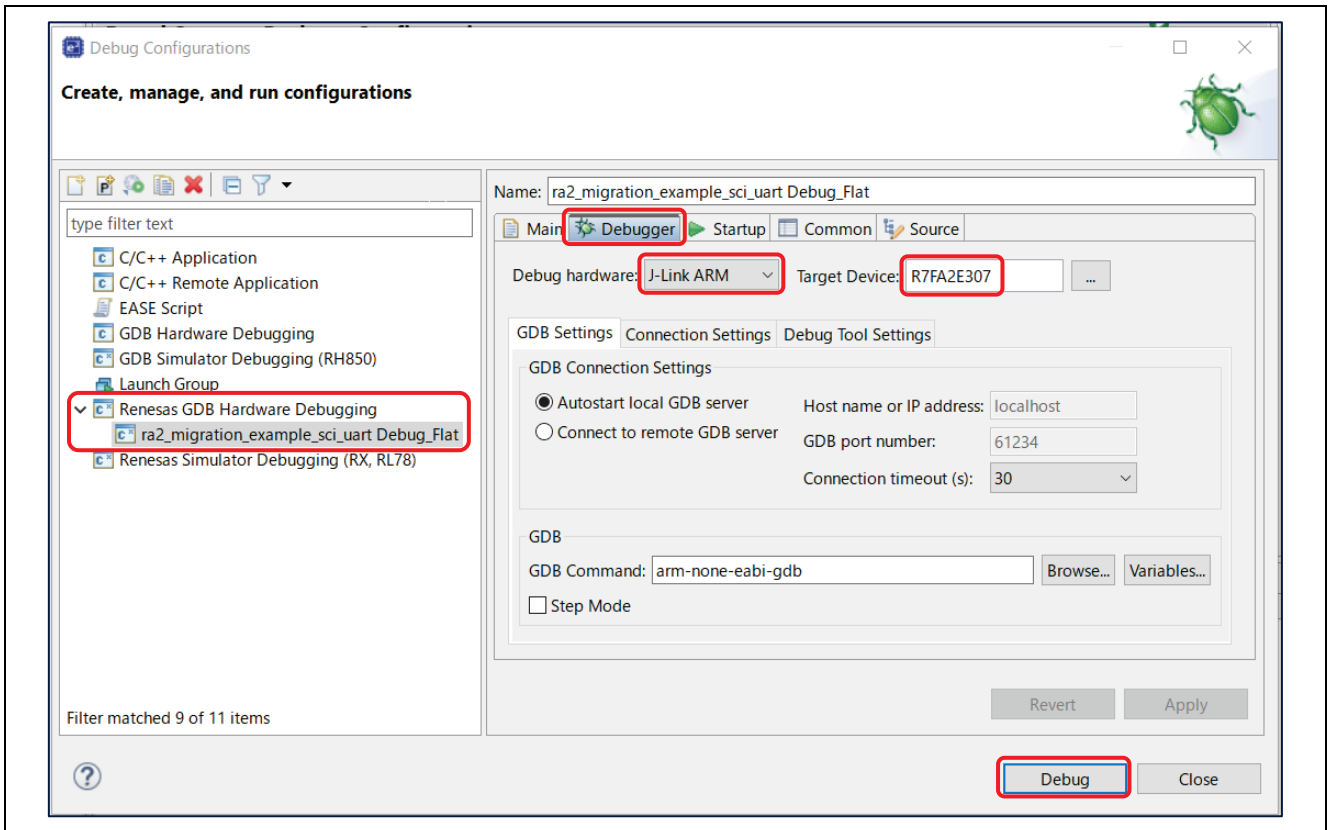

Figure 17. Project Download (2)

4.3 J-Link RTT Viewer Connection

Launch J-Link RTT Viewer. After startup, the Configuration screen is displayed.

In the Connection to J-Link setting, select **Existing Session** and check the **Auto Reconnect** box.

In the RTT Control Block setting, check the **Auto Detection** box and press **OK**.

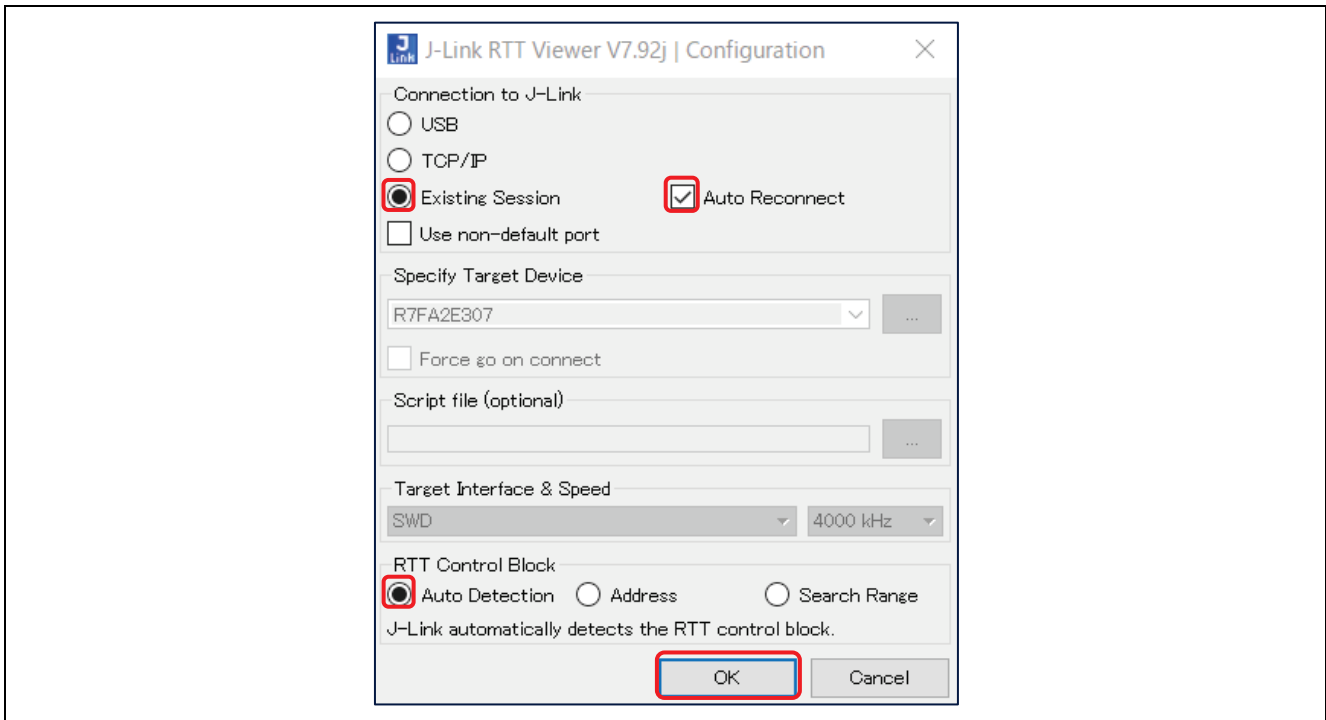

Figure 18. J-Link RTT Viewer Configuration

4.4 Tera Term Connection

1. Launch Tera Term. After startup, the settings screen will be displayed.

Check **Serial**, select the port to which the USB-TTL serial conversion cable is connected, and press **OK**.

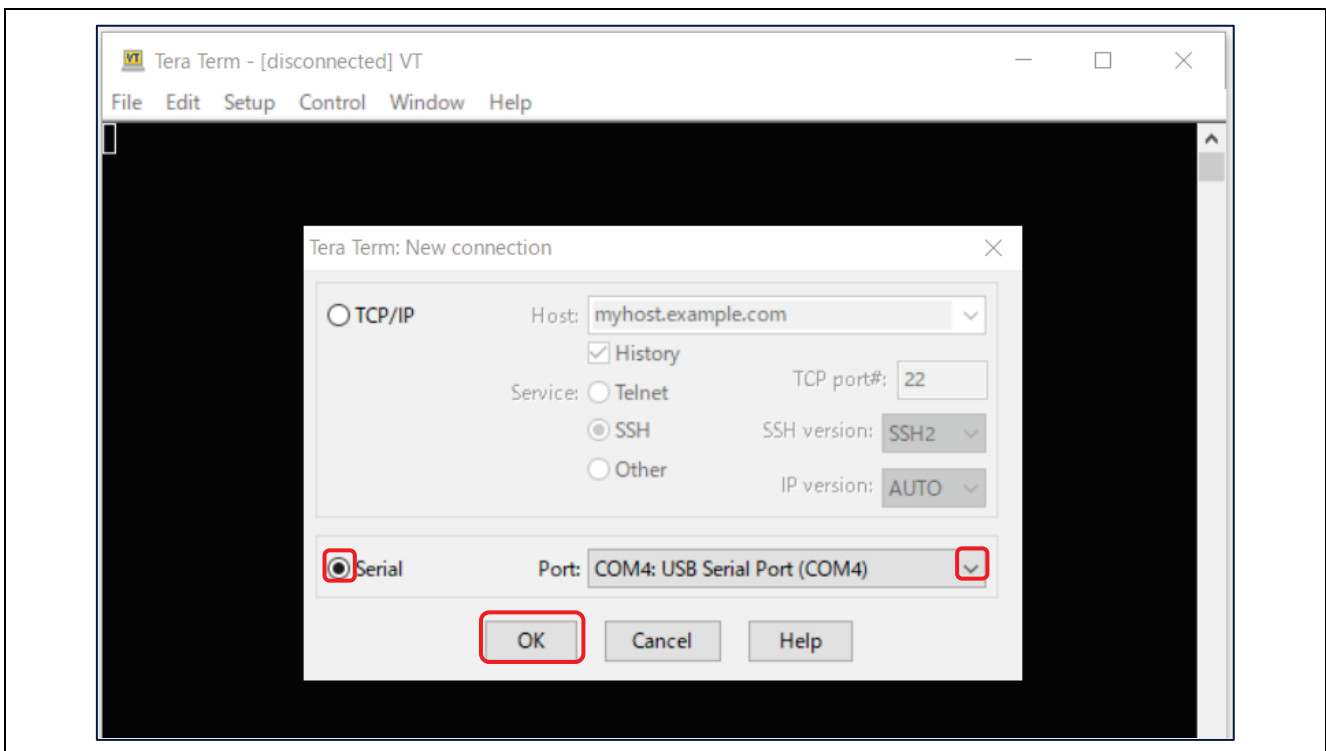

Figure 19. Tera Term connection Setting

2. Select **Setup > Serial port...** to open the screen for Serial port setup and connection. Set the speed to 115200 and press **New setting**.

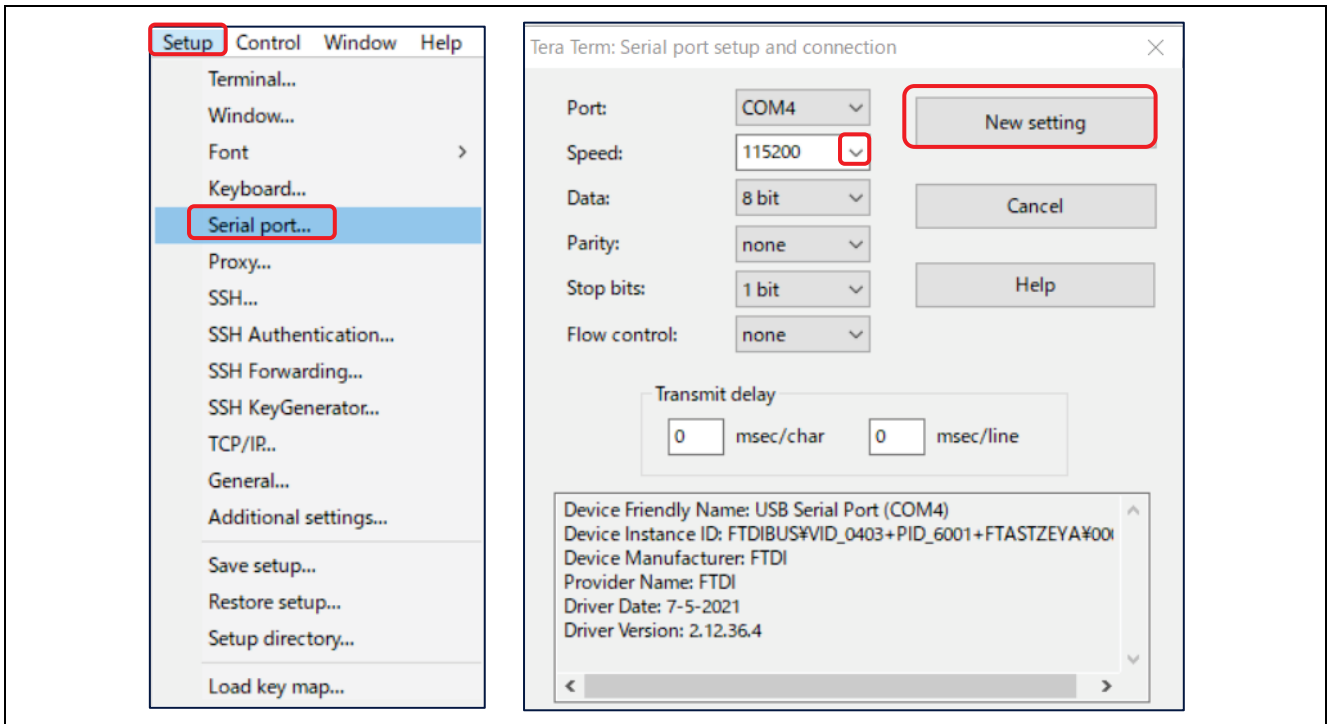

Figure 20. Tera Term Serial Port Setting

3. Select **Setup > Terminal** to open the screen for Terminal setup.
Check the **Local echo** box and press **OK**.

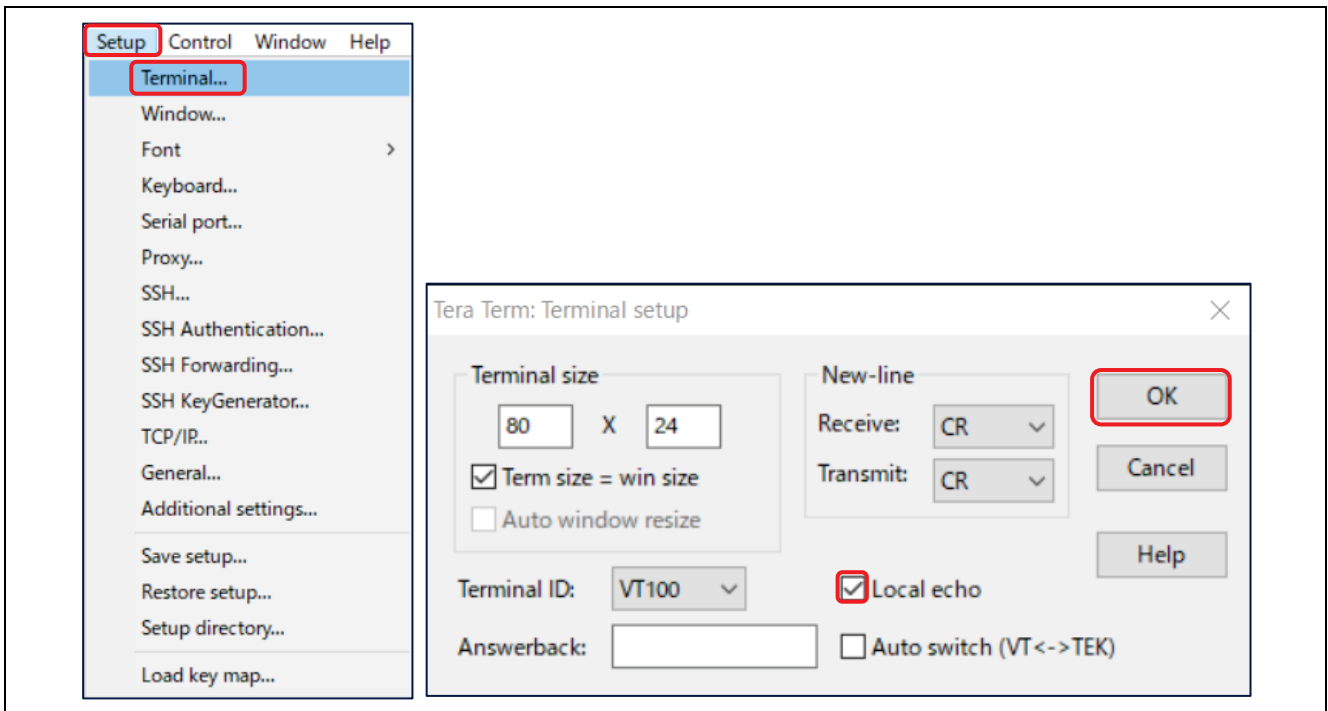



Figure 21. Tera Term Terminal Setting

4.5 Running the Project

Press the resume icon  twice in the e² studio IDE to run the program.

Verify that the program is running as described in section 2.1.

Website and Support

Visit the following URLs to learn about the RA family of microcontrollers, download tools and documentation, and get support.

RA Product Information	renesas.com/ra
Flexible Software Package (FSP)	renesas.com/ra/fsp
RA Product Support Forum	renesas.com/ra/forum
Renesas Support	renesas.com/support

Revision History

Rev.	Date	Description	
		Page	Summary
1.00	Nov.27.23	-	First release

General Precautions in the Handling of Microprocessing Unit and Microcontroller Unit Products

The following usage notes are applicable to all Microprocessing unit and Microcontroller unit products from Renesas. For detailed usage notes on the products covered by this document, refer to the relevant sections of the document as well as any technical updates that have been issued for the products.

1. Precaution against Electrostatic Discharge (ESD)

A strong electrical field, when exposed to a CMOS device, can cause destruction of the gate oxide and ultimately degrade the device operation. Steps must be taken to stop the generation of static electricity as much as possible, and quickly dissipate it when it occurs. Environmental control must be adequate. When it is dry, a humidifier should be used. This is recommended to avoid using insulators that can easily build up static electricity. Semiconductor devices must be stored and transported in an anti-static container, static shielding bag or conductive material. All test and measurement tools including work benches and floors must be grounded. The operator must also be grounded using a wrist strap. Semiconductor devices must not be touched with bare hands. Similar precautions must be taken for printed circuit boards with mounted semiconductor devices.

2. Processing at power-on

The state of the product is undefined at the time when power is supplied. The states of internal circuits in the LSI are indeterminate and the states of register settings and pins are undefined at the time when power is supplied. In a finished product where the reset signal is applied to the external reset pin, the states of pins are not guaranteed from the time when power is supplied until the reset process is completed. In a similar way, the states of pins in a product that is reset by an on-chip power-on reset function are not guaranteed from the time when power is supplied until the power reaches the level at which resetting is specified.

3. Input of signal during power-off state

Do not input signals or an I/O pull-up power supply while the device is powered off. The current injection that results from input of such a signal or I/O pull-up power supply may cause malfunction and the abnormal current that passes in the device at this time may cause degradation of internal elements. Follow the guideline for input signal during power-off state as described in your product documentation.

4. Handling of unused pins

Handle unused pins in accordance with the directions given under handling of unused pins in the manual. The input pins of CMOS products are generally in the high-impedance state. In operation with an unused pin in the open-circuit state, extra electromagnetic noise is induced in the vicinity of the LSI, an associated shoot-through current flows internally, and malfunctions occur due to the false recognition of the pin state as an input signal become possible.

5. Clock signals

After applying a reset, only release the reset line after the operating clock signal becomes stable. When switching the clock signal during program execution, wait until the target clock signal is stabilized. When the clock signal is generated with an external resonator or from an external oscillator during a reset, ensure that the reset line is only released after full stabilization of the clock signal. Additionally, when switching to a clock signal produced with an external resonator or by an external oscillator while program execution is in progress, wait until the target clock signal is stable.

6. Voltage application waveform at input pin

Waveform distortion due to input noise or a reflected wave may cause malfunction. If the input of the CMOS device stays in the area between V_{IL} (Max.) and V_{IH} (Min.) due to noise, for example, the device may malfunction. Take care to prevent chattering noise from entering the device when the input level is fixed, and also in the transition period when the input level passes through the area between V_{IL} (Max.) and V_{IH} (Min.).

7. Prohibition of access to reserved addresses

Access to reserved addresses is prohibited. The reserved addresses are provided for possible future expansion of functions. Do not access these addresses as the correct operation of the LSI is not guaranteed.

8. Differences between products

Before changing from one product to another, for example to a product with a different part number, confirm that the change will not lead to problems. The characteristics of a microprocessing unit or microcontroller unit products in the same group but having a different part number might differ in terms of internal memory capacity, layout pattern, and other factors, which can affect the ranges of electrical characteristics, such as characteristic values, operating margins, immunity to noise, and amount of radiated noise. When changing to a product with a different part number, implement a system-evaluation test for the given product.

Notice

1. Descriptions of circuits, software and other related information in this document are provided only to illustrate the operation of semiconductor products and application examples. You are fully responsible for the incorporation or any other use of the circuits, software, and information in the design of your product or system. Renesas Electronics disclaims any and all liability for any losses and damages incurred by you or third parties arising from the use of these circuits, software, or information.
2. Renesas Electronics hereby expressly disclaims any warranties against and liability for infringement or any other claims involving patents, copyrights, or other intellectual property rights of third parties, by or arising from the use of Renesas Electronics products or technical information described in this document, including but not limited to, the product data, drawings, charts, programs, algorithms, and application examples.
3. No license, express, implied or otherwise, is granted hereby under any patents, copyrights or other intellectual property rights of Renesas Electronics or others.
4. You shall be responsible for determining what licenses are required from any third parties, and obtaining such licenses for the lawful import, export, manufacture, sales, utilization, distribution or other disposal of any products incorporating Renesas Electronics products, if required.
5. You shall not alter, modify, copy, or reverse engineer any Renesas Electronics product, whether in whole or in part. Renesas Electronics disclaims any and all liability for any losses or damages incurred by you or third parties arising from such alteration, modification, copying or reverse engineering.
6. Renesas Electronics products are classified according to the following two quality grades: "Standard" and "High Quality". The intended applications for each Renesas Electronics product depends on the product's quality grade, as indicated below.
 - "Standard": Computers; office equipment; communications equipment; test and measurement equipment; audio and visual equipment; home electronic appliances; machine tools; personal electronic equipment; industrial robots; etc.
 - "High Quality": Transportation equipment (automobiles, trains, ships, etc.); traffic control (traffic lights); large-scale communication equipment; key financial terminal systems; safety control equipment; etc.Unless expressly designated as a high reliability product or a product for harsh environments in a Renesas Electronics data sheet or other Renesas Electronics document, Renesas Electronics products are not intended or authorized for use in products or systems that may pose a direct threat to human life or bodily injury (artificial life support devices or systems; surgical implantations; etc.), or may cause serious property damage (space system; undersea repeaters; nuclear power control systems; aircraft control systems; key plant systems; military equipment; etc.). Renesas Electronics disclaims any and all liability for any damages or losses incurred by you or any third parties arising from the use of any Renesas Electronics product that is inconsistent with any Renesas Electronics data sheet, user's manual or other Renesas Electronics document.
7. No semiconductor product is absolutely secure. Notwithstanding any security measures or features that may be implemented in Renesas Electronics hardware or software products, Renesas Electronics shall have absolutely no liability arising out of any vulnerability or security breach, including but not limited to any unauthorized access to or use of a Renesas Electronics product or a system that uses a Renesas Electronics product. RENESAS ELECTRONICS DOES NOT WARRANT OR GUARANTEE THAT RENESAS ELECTRONICS PRODUCTS, OR ANY SYSTEMS CREATED USING RENESAS ELECTRONICS PRODUCTS WILL BE INVULNERABLE OR FREE FROM CORRUPTION, ATTACK, VIRUSES, INTERFERENCE, HACKING, DATA LOSS OR THEFT, OR OTHER SECURITY INTRUSION ("Vulnerability Issues"). RENESAS ELECTRONICS DISCLAIMS ANY AND ALL RESPONSIBILITY OR LIABILITY ARISING FROM OR RELATED TO ANY VULNERABILITY ISSUES. FURTHERMORE, TO THE EXTENT PERMITTED BY APPLICABLE LAW, RENESAS ELECTRONICS DISCLAIMS ANY AND ALL WARRANTIES, EXPRESS OR IMPLIED, WITH RESPECT TO THIS DOCUMENT AND ANY RELATED OR ACCOMPANYING SOFTWARE OR HARDWARE, INCLUDING BUT NOT LIMITED TO THE IMPLIED WARRANTIES OF MERCHANTABILITY, OR FITNESS FOR A PARTICULAR PURPOSE.
8. When using Renesas Electronics products, refer to the latest product information (data sheets, user's manuals, application notes, "General Notes for Handling and Using Semiconductor Devices" in the reliability handbook, etc.), and ensure that usage conditions are within the ranges specified by Renesas Electronics with respect to maximum ratings, operating power supply voltage range, heat dissipation characteristics, installation, etc. Renesas Electronics disclaims any and all liability for any malfunctions, failure or accident arising out of the use of Renesas Electronics products outside of such specified ranges.
9. Although Renesas Electronics endeavors to improve the quality and reliability of Renesas Electronics products, semiconductor products have specific characteristics, such as the occurrence of failure at a certain rate and malfunctions under certain use conditions. Unless designated as a high reliability product or a product for harsh environments in a Renesas Electronics data sheet or other Renesas Electronics document, Renesas Electronics products are not subject to radiation resistance design. You are responsible for implementing safety measures to guard against the possibility of bodily injury, injury or damage caused by fire, and/or danger to the public in the event of a failure or malfunction of Renesas Electronics products, such as safety design for hardware and software, including but not limited to redundancy, fire control and malfunction prevention, appropriate treatment for aging degradation or any other appropriate measures. Because the evaluation of microcomputer software alone is very difficult and impractical, you are responsible for evaluating the safety of the final products or systems manufactured by you.
10. Please contact a Renesas Electronics sales office for details as to environmental matters such as the environmental compatibility of each Renesas Electronics product. You are responsible for carefully and sufficiently investigating applicable laws and regulations that regulate the inclusion or use of controlled substances, including without limitation, the EU RoHS Directive, and using Renesas Electronics products in compliance with all these applicable laws and regulations. Renesas Electronics disclaims any and all liability for damages or losses occurring as a result of your noncompliance with applicable laws and regulations.
11. Renesas Electronics products and technologies shall not be used for or incorporated into any products or systems whose manufacture, use, or sale is prohibited under any applicable domestic or foreign laws or regulations. You shall comply with any applicable export control laws and regulations promulgated and administered by the governments of any countries asserting jurisdiction over the parties or transactions.
12. It is the responsibility of the buyer or distributor of Renesas Electronics products, or any other party who distributes, disposes of, or otherwise sells or transfers the product to a third party, to notify such third party in advance of the contents and conditions set forth in this document.
13. This document shall not be reprinted, reproduced or duplicated in any form, in whole or in part, without prior written consent of Renesas Electronics.
14. Please contact a Renesas Electronics sales office if you have any questions regarding the information contained in this document or Renesas Electronics products.

(Note1) "Renesas Electronics" as used in this document means Renesas Electronics Corporation and also includes its directly or indirectly controlled subsidiaries.

(Note2) "Renesas Electronics product(s)" means any product developed or manufactured by or for Renesas Electronics.

(Rev.5.0-1 October 2020)

Corporate Headquarters

TOYOSU FORESIA, 3-2-24 Toyosu,
Koto-ku, Tokyo 135-0061, Japan
www.renesas.com

Trademarks

Renesas and the Renesas logo are trademarks of Renesas Electronics Corporation. All trademarks and registered trademarks are the property of their respective owners.

Contact information

For further information on a product, technology, the most up-to-date version of a document, or your nearest sales office, please visit:
www.renesas.com/contact/.