

RX23E-A Group

Usage of Low Power Function for sensor measurement

Summary

This document describes a method to reduce power consumption by combining low power consumption functions and intermittent operation. The RX23E-A is an MCU that integrates an analog front end (AFE) and a CPU on a single chip. The 24-bit Δ - Σ A/D converter (DSAD) mounted on the AFE section has a low power mode in addition to a normal mode. The CPU has a deep sleep mode and a software standby mode. Combining these low power consumption functions of the RX23E-A with intermittent operation makes it possible to support low power applications. In this document, we actually measured the current consumption using an RSSK board and a sample program that implements low power consumption functions and intermittent operation.

For the AFE section, current consumption is reduced by stopping the AFE module during standby. For the CPU section, current consumption is reduced by minimizing CPU operation time by switching to software standby mode during standby and deep sleep mode during A/D conversion. Converted into power, this is equivalent to 0.005mW for the AFE section and 0.002mW for the CPU section, for a total of 0.007mW. The RMS noise during measurement was 4.642 μ Vrms (20.04bit), confirming that noise performance was obtained.

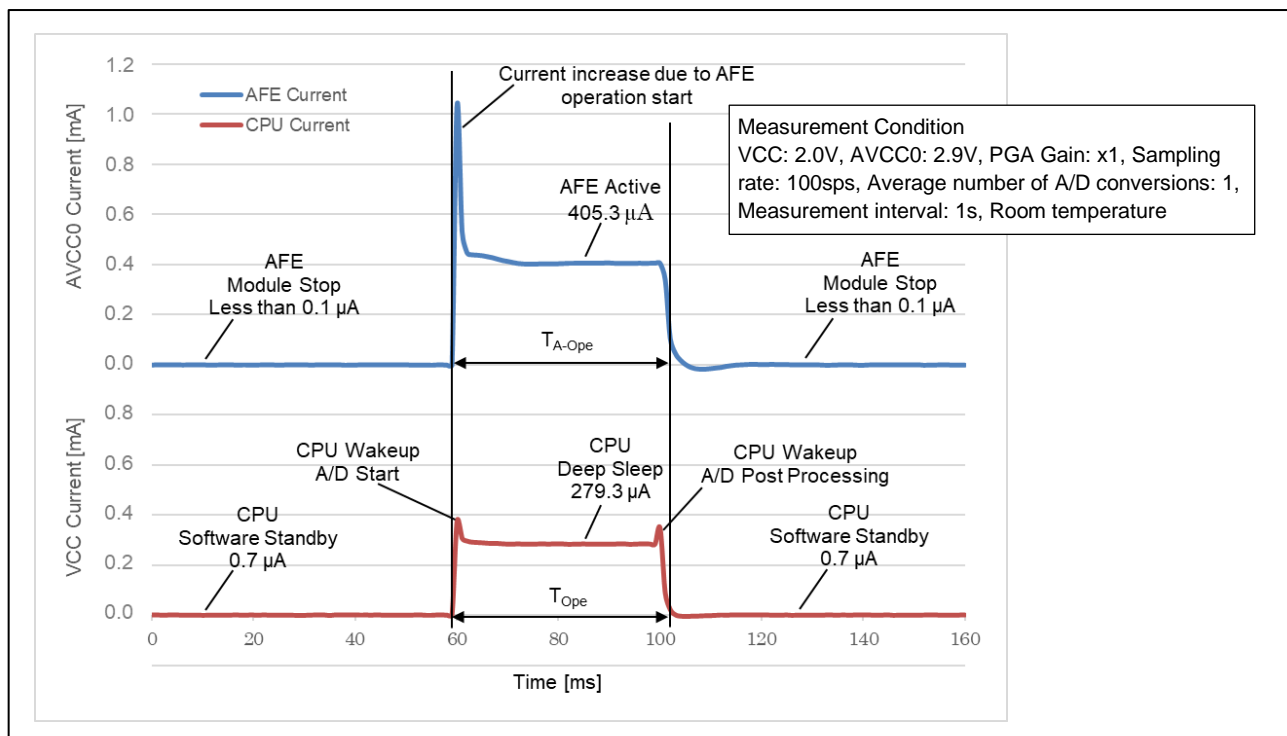

Current consumption measurement example

Target applications

Battery-powered wireless and portable instruments

- Temperature sensor, Strain gauge, Gas detector, Liquid analyzer

Target device

RX23E-A (R5F523E6ADFL)

Contents

1. Overview	3
1.1 Application to RX23E-A	5
1.2 How to select measurement trigger	6
1.3 Operating mode and setting values	6
1.3.1 Operable Items in Data Acquisition Mode	7
1.3.2 Operable Items in Measurement Setting Mode	8
1.4 Measurement Procedure	9
2. Environment for Operation Confirmation	10
3. Related Documents	10
4. System Overview	11
4.1 Hardware Configuration	11
4.2 Explanation of Operation	15
4.2.1 Intermittent operation	15
4.2.2 Voltage Measurement	16
5. Sample Program	17
5.1 Overview of Operation	17
5.2 Functions and Settings of MCU Used	19
5.2.1 Voltage Measurement	20
5.2.2 Communication	22
5.2.3 I/O Ports and Interrupt Controller Settings	24
5.2.4 LED and Switch	25
5.3 Measurement Mode	26
5.4 Communication Mode	28
5.5 Program Configuration	30
5.5.1 File configuration	30
5.5.2 Macro Definitions	32
5.5.3 Structures and Unions	33
5.5.4 Functions	34
6. Import a Project	40
6.1 Importing a Project into e ² studio	40
6.2 Importing a Project into CS+	41
7. Measurement Result Using Sample Program	42
7.1 Memory Usage	42
7.1.1 Build Conditions	42
7.1.2 Memory Usage	42
7.1.3 Execution Cycle and Processing Time in Measurement Mode	42
7.2 Evaluation Condition	43
7.3 Evaluation Results	45
Revision History	47

1. Overview

The application assumed to be targeted by this document is a battery-powered wireless portable measuring instrument, which requires both low power consumption performance and measurement accuracy. In such instruments, it is important to keep each power consuming function such as sensors, AFE, and MCU operating at the minimum necessary while keeping the entire system operating efficiently.

One of the methods to reduce power consumption of measuring instruments is intermittent operation. In intermittent operation, the system periodically repeats the operation that stops the MCU and/or AFE, shifts to the low-power consumption state, and resumes only the necessary section to the normal state if necessary. When measuring, the system shifts from the low-power state to the normal state. The state transition is triggered by the interrupt request signal from the on-chip timer or the external input signal. Examples of external input signal sources are host system, RTC, and so on.

Table 1-1 shows an example of a measurement instrument system with intermittent operation. The difference between configuration 1 and 2 is the method to generate the interrupt request signal for intermittent operation, and the others are the same. The system configuration 1 receives the signal from outside of the MCU, and the system configuration 2 uses the MCU on-chip timer.

The method to receive the signal from outside of the MCU (Table 1-1, System configuration 1) requires a host system or RTC outside of the MCU, but it allows flexible operation because it does not use an MCU on-chip timer. On the other hand, the method to use a MCU on-chip timer (Table 1-1, System configuration 2) does not need additional components, but there are some limitations due to the number or performance of the MCU timers.

Table 1-1 Examples of intermittent operation measurement system

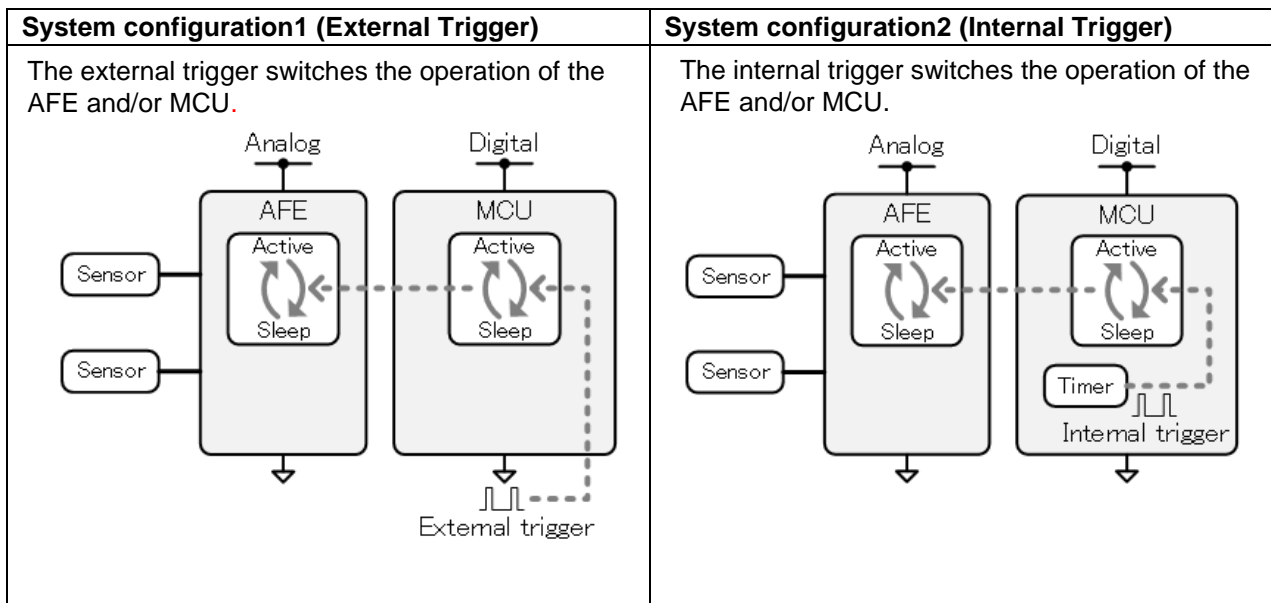

RX23E-A is an MCU with various power-saving functions to implement low-power operation.

Table 1-2 shows examples of the portable battery-powered measurement system with intermittent operation by RX23E-A. As shown in Table 1-2, RX23E-A enables the intermittent measurement system shown in Table 1-1. For details on RX23E-A power-saving functions, low-power timer, and DSAD, refer to the related section in RX23E-A Group User's Manual: Hardware.

- 11. Low Power Consumption
- 26. Low-Power Timer (LPT)
- 34. 24-bit Delta-Sigma A/D Converters (DSADA)

Table 1-2 Examples of intermittent operation measurement system using RX23E-A

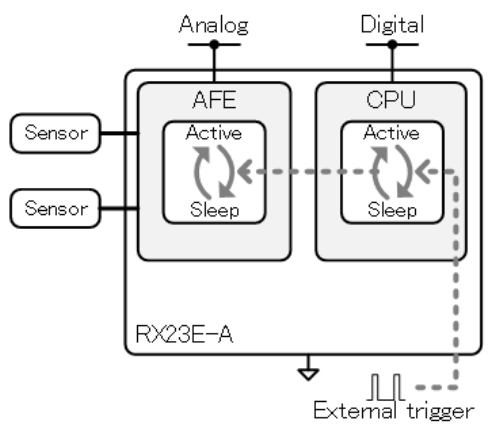
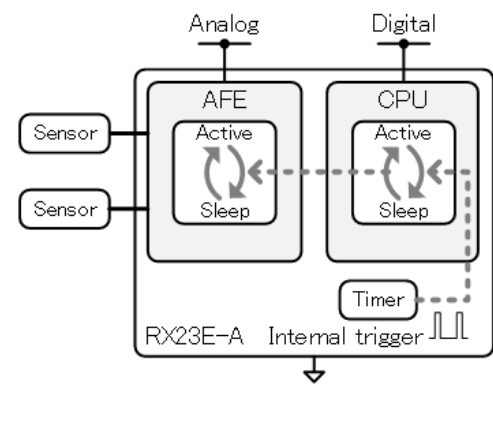
Item	System configuration1 (External Trigger)	System configuration2 (Internal Trigger)
System configuration diagram	<p>The external trigger switches the operation of the AFE and/or CPU.</p> 	<p>The internal trigger switches the operation of the AFE and/or CPU.</p> 
System features	As it should receive the measurement timing externally, additional components (MCU, RTC module, etc.) are required.	As no need to receive the trigger signal externally, no need for external device to generate the measurement interval, nor wiring.
Measurement trigger generation/ Measurement cycle	Optimal components to input measurement trigger externally can be selected based on the product specification. The measurement interval can be set in a wider range (from several hundreds of msec to several years).	It can be generated by the LPT built in RX23E-A. The measurement cycle can be set within the LPT specification (139 sec Max.). For over 139-sec cycle, use a software counter together.
Power consumption	As an external module such as RTC is used, the power consumption is increased by that amount.	To measure at an interval that exceeds the LPT time setting, software counting process is required, and the power consumed by CPU is increased.

1.1 Application to RX23E-A

This document describes an example of using the power-saving functions of RX23E-A and how to perform A/D conversion with intermittent operation. As the RX23E-A power-saving function, the software standby mode and deep sleep mode, module stop function are used. The interrupt request to return from software standby mode to the normal state supports 1. Internal trigger (on-chip timer), and 2. External trigger (external input).

To operate intermittent measurement, the system is in the deep sleep mode during measurement operation, and the system is in the software standby mode when waiting (during low-power operation).

The sample program runs on the RSSK board, and PC tool Program allows users to configure the measurement conditions, perform calibration, and obtain the measurement results. Can store the measurement data up to 4096. Figure 1-1 shows an example of RX23E-A low-power measurement system.

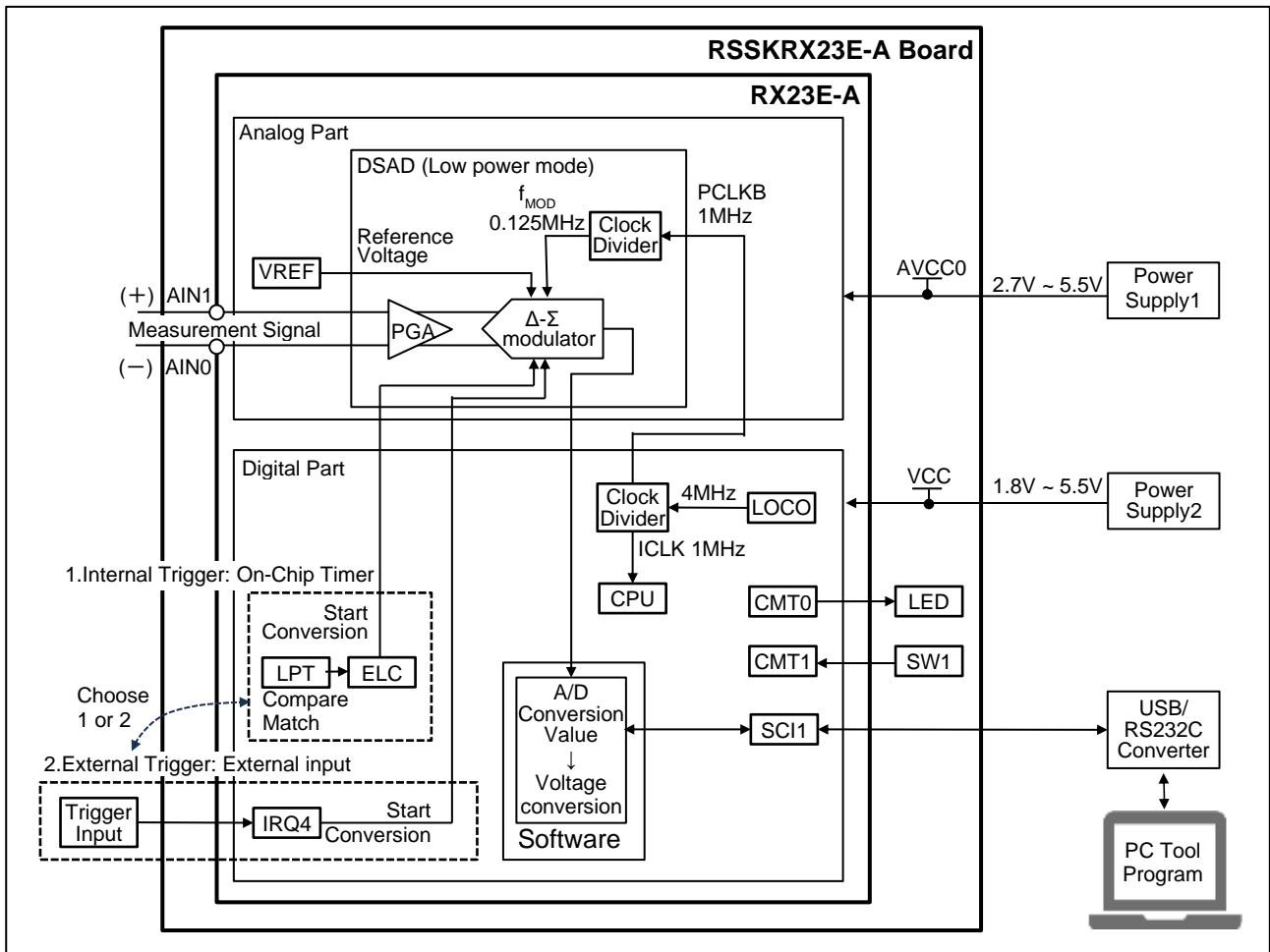

Figure 1-1 Example of RX23E-A low-power measurement system

1.2 How to Select Measurement Trigger

This sample program supports both internal and external triggers. To switch the measurement trigger, compile it under the condition in Table 1-3. After compiling, write the sample program to RX23E-A. Compiled object programs (*.mot files) for each measurement trigger are also included in the sample program set.

Table 1-3 Operable items (macro setting change)

Compile condition		Operation specification
e ² Studio	Internal Trigger: set on-chip timer [Build configuration] -> [Active] -> [Use LPT], and compile	Measurement cycle 1 sec: fix pin PB1 to High 5 min: fix pin PB1 to Low
	External Trigger: set external input [Build configuration] -> [Active] -> [Use IRQ4], and compile	Measurement cycle Depends on the external trigger. A/D measurement is triggered when detecting the external input rising edge.

Note: This system performs A/D conversion at 100SPS (=every 10ms). Settling takes about 40ms, so this system does not assume triggers with the interval less than 40ms.

1.3 Operating Mode and Setting Values

This system has three operating modes. Table 1-4 shows the functions of each mode. The initial setting is No.1 Data acquisition mode, and the modes can be switched as “No.1→No.2→No.3→No.1...” with SW1 of RSSK. In communication mode, you can change settings and obtain measurement data by connecting to a PC using the Windows GUI program PC Tool Program.

Table 1-4 Operating mode

No.	Name		LED1 state	Main operation	PC Tool Program operation TAB
1	Communication mode	Data acquisition mode	Blinking at intervals of 0.25sec	Transmission of measured data (voltage value)	Application TAB
				Alert threshold setting	Application TAB
2		Measurement setting mode	Blinking at intervals of 0.5sec	Register setting	Resisters TAB
				Calibration	Resisters TAB
3	Measurement mode	Measurement mode	OFF	A/D measurement by intermittent operation, voltage conversion	No connection to PC Tool Program

1.3.1 Operable Items in Data Acquisition Mode

Table 1-5 and Figure 1-2 shows the operable items in the data acquisition mode.

Table 1-5 Operable items of Data acquisition mode

Operation target	Item	Operation	
PC Tool Program	Top of the TAB	Connect/Disconnect	Press Connect/Disconnect button.
	Application TAB	Setting of alert threshold for measured voltage	Command Value text box ^{Note} , Set button Setting range: 0-10[V] (Initial value:10[V])
	Application TAB	Get measurement data	Press Run button to get measurement voltage data stored in memory.
	Application TAB	Measurement data output	Lists measurement data. The range of the list can be selected and copied in CSV format.

Note: Due to the specifications of PC Tool Program, the setting value cannot be read when connecting to PC, and the initial value of the sample program is set to 10V.

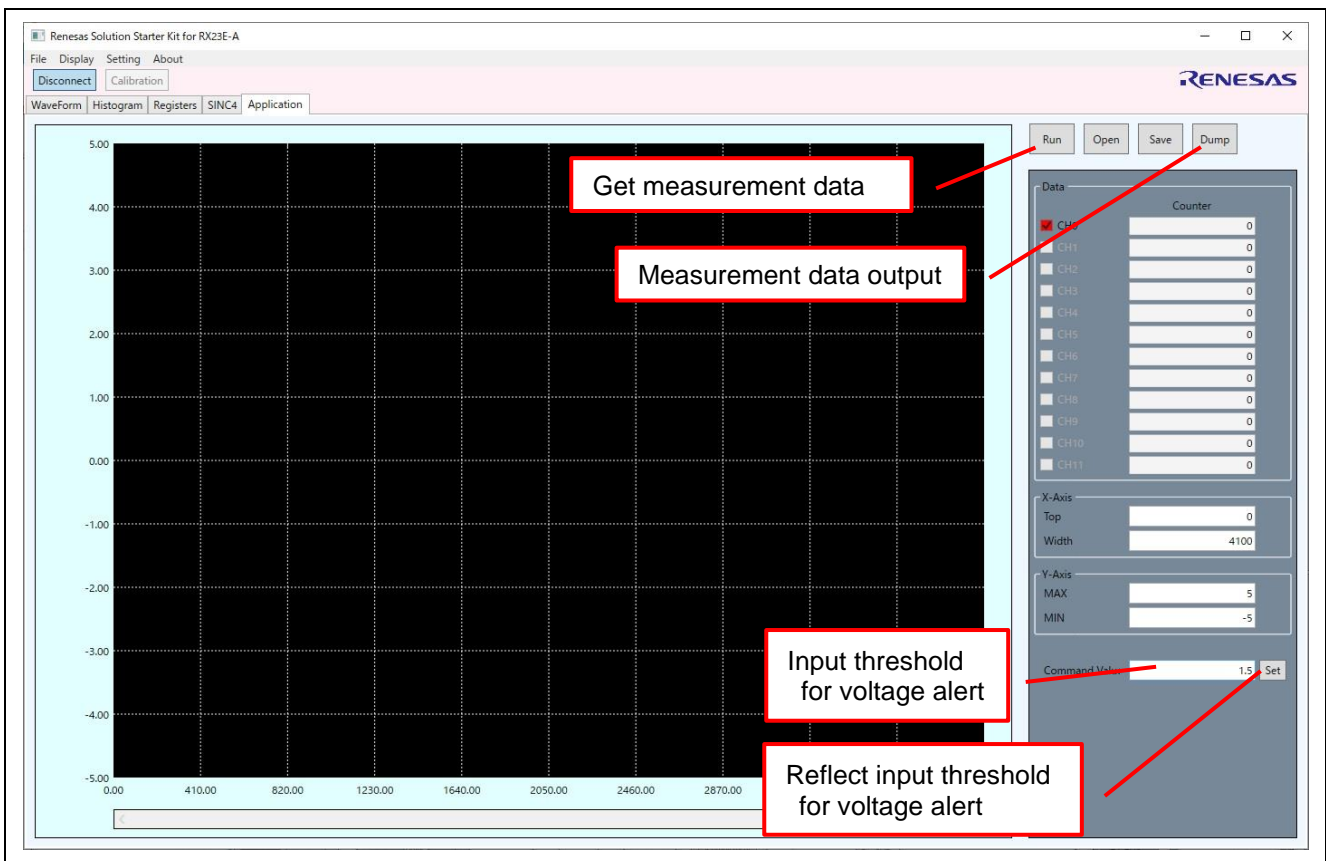

Figure 1-2 PC Tool Program Application TAB

1.3.2 Operable Items in Measurement Setting Mode

Table 1-6 and Figure 1-3, Figure 1-4 show the operable items in the Measurement Setting mode.

Table 1-6 Operable items of Measurement setting mode^{Note2}

Operation target	Item	Operation	
PC Tool Program	Top of the TAB	Connect/Disconnect	Press Connect/Disconnect button
	SINC4 TAB, Registers TAB	DSAD0 averaging count setting	After setting the averaging count on SINC4 TAB, press the Apply button to move to Register TAB, and press the Set button. Initial value: 1 Setting value: 1 or 16
	Registers TAB	AFE power supply mode setting	Select from the DSADLVM pull down list and press the Set button. Initial setting: 2.7V <= AVCC0 Setting: 2.7V <= AVCC0 or 3.6V <= AVCC0
	Registers TAB	DSAD0 PGA gain setting	Select the setting value and press the Set button. Initial value: 1, Setting value: 1 or 128
	Top of the TAB	Calibration ^{Note1}	Press the Calibration button.
	Registers TAB	Calibration correction value setting	After calibration, check the checkmarks on GCR0 and OFCR0 in Register TAB and press the Set button.

Notes: 1. Calibration can be performed when RSSK and the PC are connected AND in Measurement setting mode. For details on calibration, refer to RSSKRX23E-A PC Tool Program Operation Manual. If the power is turned off, the calibration correction value is deleted. When supplying the power again, perform calibration again. When the gain is changed, calibration is required as well. For the calibration condition for this evaluation, refer to 7.2.

2. If you configure settings other than those specified, it may not operate correctly.

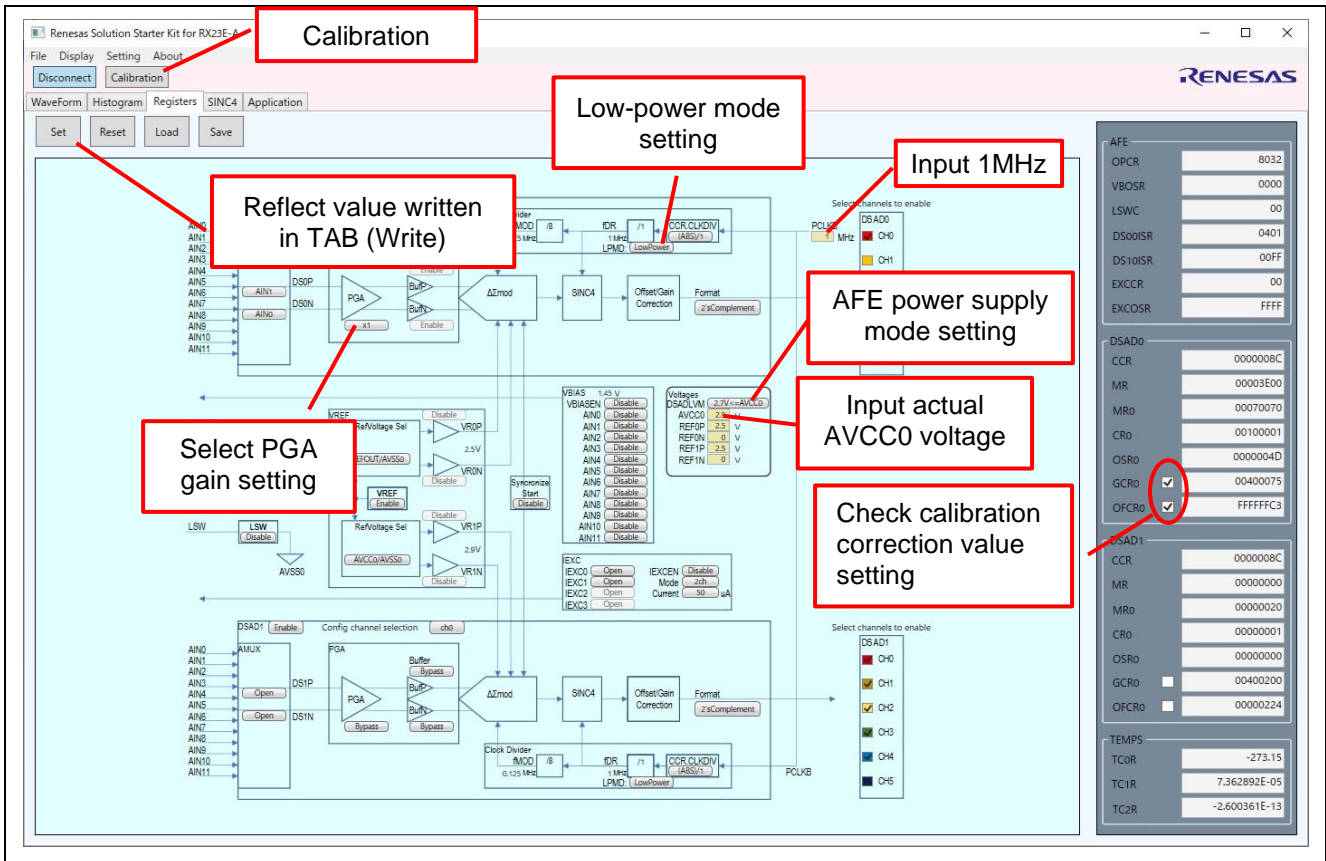

Figure 1-3 PC Tool Program Register TAB



Figure 1-4 PC Tool Program SINC4 TAB

1.4 Measurement Procedure

Table 1-7 shows the measurement procedure of this system.

Table 1-7 Low power measurement system Measurement procedure

No	Item	Description
1	Evaluation preparation	change the RSSK board by referring to 4.1.
2	Power on	Apply power to the RSSK board.
3	Measurement settings	Set AFE and DSAD from PC Tool Program. The configurable values and setting method are described in 1.3.2. Check that the LED is flashing at 1 sec intervals.
4	Calibration	Perform calibration before measurement. It is necessary to set the low-power offset correction value and gain correction value for the DSAD low-power mode. The calibration conditions for the evaluation results in this APN are listed in Table 7-6. For details, please refer to 1.3.2 and the RSSKRX23E-A PC Tool Program Operation Manual. Make sure that the LED is flashing at 1 sec intervals.
5	Measurement	Measure under the conditions set in step 4.
6	Data acquisition	After connecting to the PC Tool Program, you can check the results in the Application tab. For details, see 1.3.1 and the RSSKRX23E-A PC Tool Program Operation Manual. Make sure the LED is flashing at 0.5 sec intervals.

2. Environment for Operation Confirmation

Table 2-1 Environment for Operation Confirmation

Item	Description
Board	RSSKRX23E-A board (RTK0ESXB10C00001BJ)
MCU	RX23E-A (R5F523E6ADFL) Power voltage VCC: 2.0V AVCC0: 2.9V or 5.0V Clock source: LOCO 4MHz Operating frequency (ICLK): 1MHz Peripheral operating frequency (PCLKB): 1MHz DSAD0 modulator clock frequency (f _{MOD}): 0.125MHz DSAD0 operating mode: low-power mode
RS485-USB I/F	AE-UM232R (AKIZUKI DENSHI TSUSHO) VCCIO:2.0V
IDE	e2studio 2024-10 (Renesas Electronics) Renesas Smart Configurator V24.10.0
Tool Chain	Renesas CC-RX V3.06.00
Emulator	Renesas E2 Emulator Lite (RTE0T0002LKCE00000R)
PC Program	Renesas Solution Starter Kit for RX23E-A Ver2.01

Figure 2-1 shows the clock generation circuit of this system. Use LOCO to generate clocks for each operating frequency.

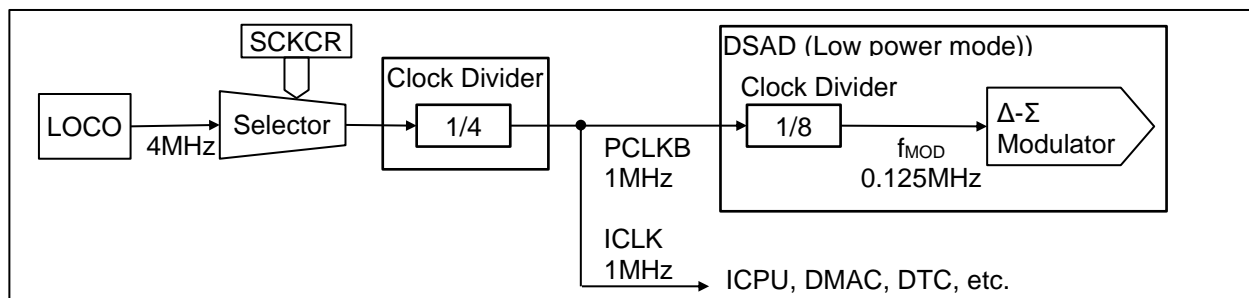

Figure 2-1 Block diagram of clock generation circuit

3. Related Documents

- R01UH0801 RX23E-A Group User’s Manual: Hardware
- R20UT4542 RSSKRX23E-A User's Manual
- R20AN0540 RSSKRX23E-A PC Tool Program Operation Manual

4. System Overview

4.1 Hardware Configuration

The changes made to the RSSKRX23E-A board are shown in Table 4-1. For details on RSSK, refer to RSSKRX23E-A User's Manual.

Table 4-1 Changes made to the RSSKRX23E-A board

Part reference No.	Before change	After change	Why changed
R52, R58, R59, R66, R70, R89, R90, R98, R99	0	DNF ^{Note2}	To shut down the unused ICs power supply
R64, R65, R94	33	DNF	
R95	390	DNF	
R56	3.9k	DNF	
R26 ^{Note1} , R69	10k	DNF	
J2-9, J2-10, J2-11, J2-12, J3-3, J3-4, J3-7, J3-8, J3-9, J3-10, J4-7, J4-9, J5-1, J5-3	DNF	10kΩ	To connect pull-up resistors
R62, R63	DNF	0Ω	J5: for UART pin connection
D1, D3	40V 2A	DNF	To prevent leakage current of negative direction ^{Note 3}

Notes: 1. Remove only when using external input.

2. DNF: Do Not Fit

3. Be careful not to connect the power supply in reverse.

Table 4-2 Unused pin settings

Pin No	Pin name	I/O	Setting
1	AIN10	I	Connect to AVSS0 (Short SO12)
2	AIN11	I	Connect to AVSS0 (Short SO13)
6	P37/XTAL	Hi-Z	Connect to VCC via a resistor (pull up)
8	P36/EXTAL	Hi-Z	Connect to VCC via a resistor (pull up)
12	P35/NMI	Hi-Z	Already connected to VCC via a resistor by initial setting
13	P31/CTS1#	Hi-Z	Already connected to VCC via a resistor by initial setting
17	P17/SCK1/SDA	Hi-Z	Connect to VCC via a resistor (pull up)
18	P16/SMOSI1/SCL	Hi-Z	Connect to VCC via a resistor (pull up)
19	P15/SMISO1/CRXD0	Hi-Z	Connect to VCC via a resistor (pull up)
20	P14/SS1#/CTXD0	Hi-Z	Connect to VCC via a resistor (pull up)
21	PH3	Hi-Z	Connect to VCC via a resistor (pull up)
23	PH1/TXD5	Hi-Z	Connect to VCC via a resistor (pull up)
24	PH0/RXD5	Hi-Z	Connect to VCC via a resistor (pull up)
25	PC7/MTIOC3A	Hi-Z	Connect to VCC via a resistor (pull up)
26	PC6/MTIOC3C	Hi-Z	Connect to VCC via a resistor (pull up)
27	PC5/MTIOC3B	Hi-Z	Connect to VCC via a resistor (pull up)
28	PC4/MTIOC3D	Hi-Z	Connect to VCC via a resistor (pull up)
36	LSW	O	Connect to AVSS0 (Short SO1)
41	AIN2	I	Connect to AVSS0 (Short SO4)
42	AIN3	I	Connect to AVSS0 (Short SO5)
43	AIN4/REF1N	I	Connect to AVSS0 (Short SO6)
44	AIN5/REF1P	I	Connect to AVSS0 (Short SO7)
45	AIN6	I	Connect to AVSS0 (Short SO8)
46	AIN7	I	Connect to AVSS0 (Short SO9)
47	AIN8/IEXC1	I	Connect to AVSS0 (Short SO10)
48	AIN9/IEXC0	I	Connect to AVSS0 (Short SO11)

Table 4-3 RSSKRX23E-A board jumper settings

Function	Circuit ref number	Connection	Setting
External reference selection (REF0N)	JP7	5-6	AVSS0
External reference selection (REF0P)	JP8	5-6	AVCC0
VCC selection	JP14	1-2	V _d
AVCC0 selection	JP15	1-2	V _a

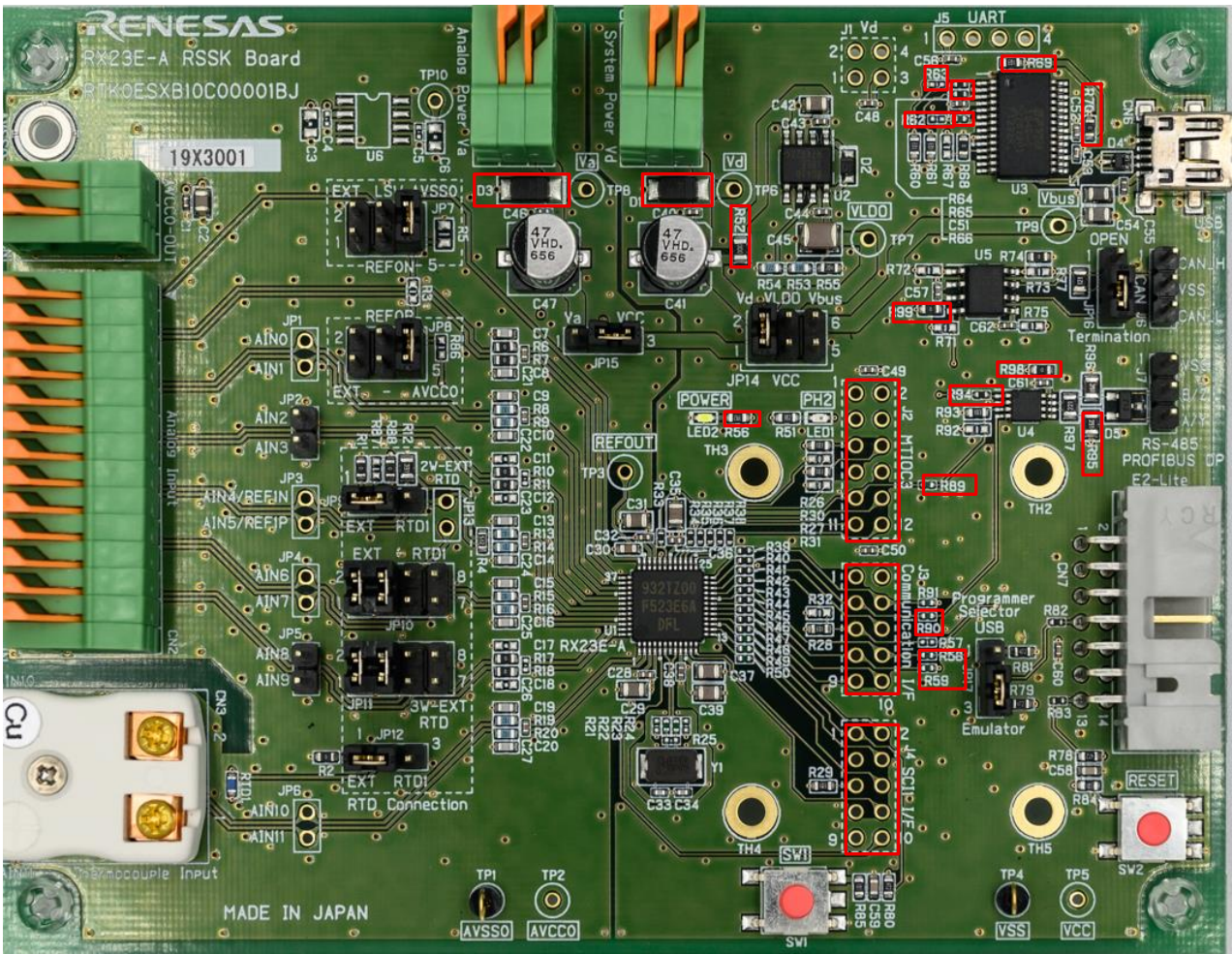

Figure 4-1 RSK RX23E-A board changed part (front side)

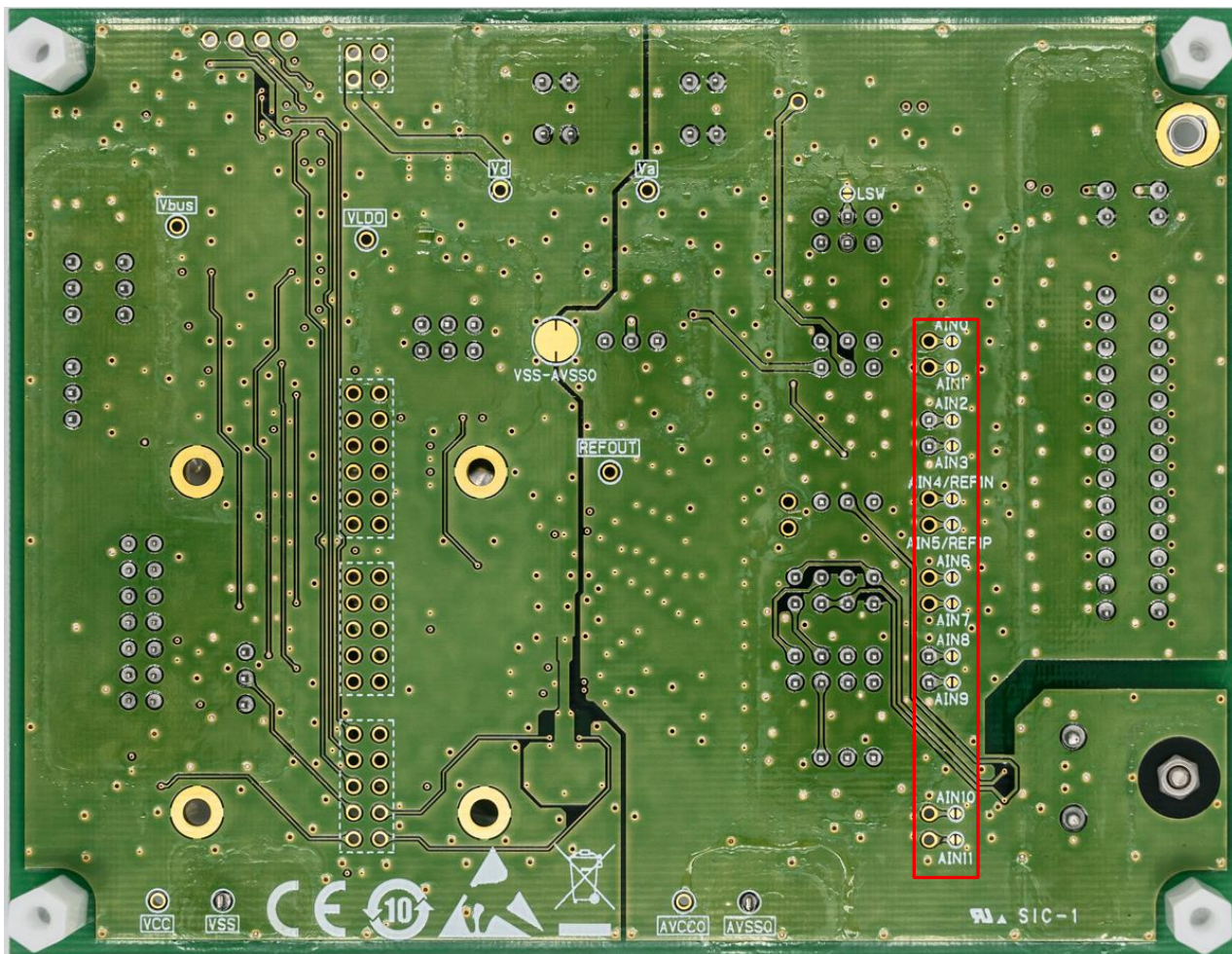

Figure 4-2 RSK RX23E-A board changed part (back side)

4.2 Explanation of Operation

4.2.1 Intermittent Operation

As shown in Table 1-4, this system allows three operating settings. Figure 4-3 shows an image of intermittent operation. The system performs the following three operations periodically for intermittent operation.

1. After the RX23E-A enters the measurement mode, the CPU enters software standby mode.
2. By the interrupt request signal, the CPU returns from the software standby mode to the normal state, starts A/D conversion, and after that, shifts to the deep-sleep mode. While the CPU shifts to deep-sleep mode, the DSAD performs A/D conversion.
3. After completion of A/D conversion, the CPU returns from the deep-sleep mode to the normal state by DSAD conversion completion interrupt (ADI0), obtains the A/D conversion result, and processes the postprocessing. After that, the state goes back to 1.

The interrupt request signal to return from software standby supports 1. On-chip timer and 2. External input.

1. On-chip timer uses the LPT, generating the interrupt request signal by generating ELC interrupt from LPT compare match event. The LPT built in RX23E-A can generate the cycle up to around 139 seconds. If you want to generate for a longer period than LTP can, it is possible by using a CPU software counter together.
2. External input uses the signal applied to PB0 (IRQ4) as the interrupt request signal. RX23E-A keeps waiting in the software standby mode until the interrupt request signal is applied.

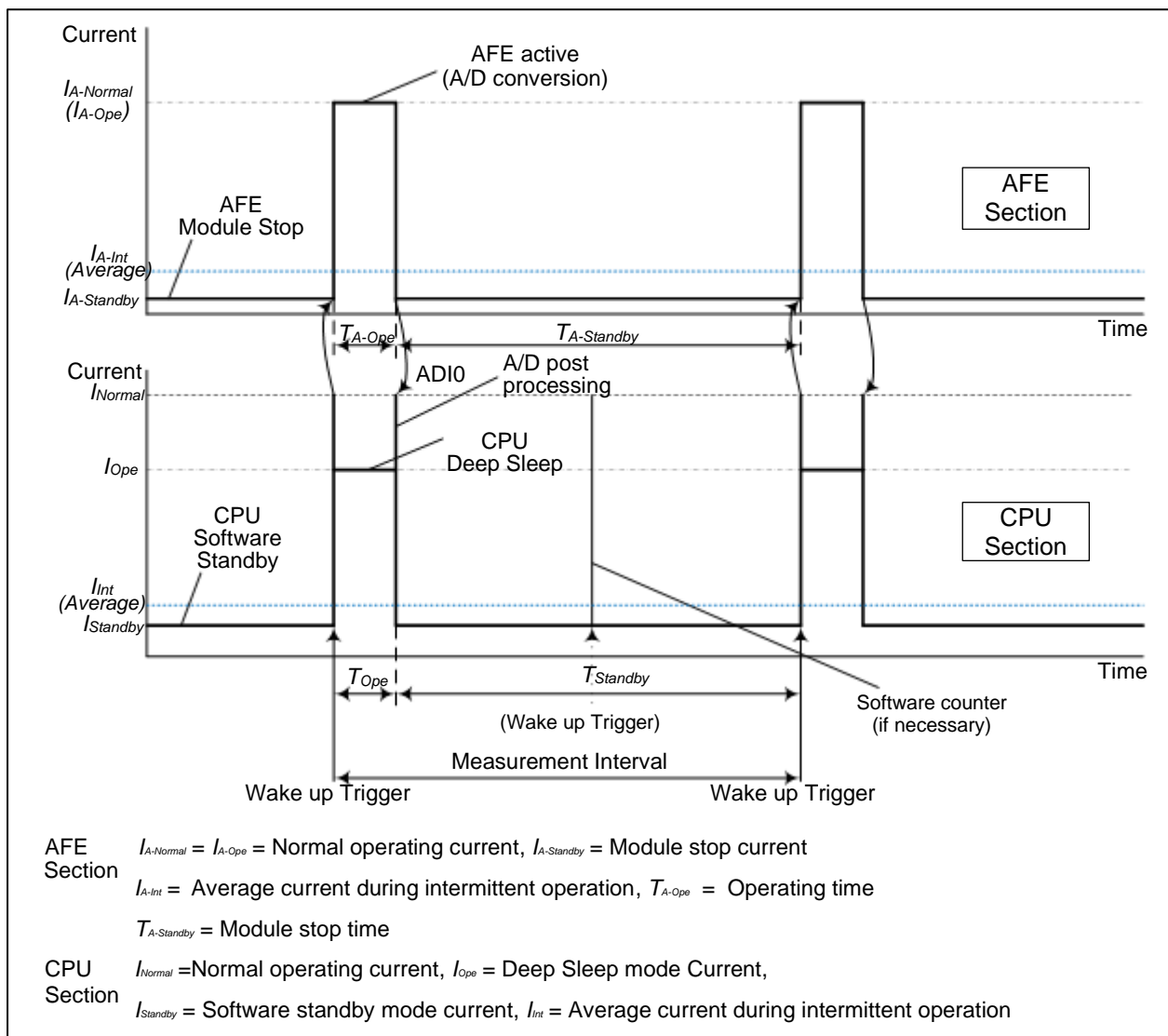

Figure 4-3 Image of intermittent operation

The following describes the operation of the CPU during intermittent operation.

Under the normal operation, the average power consumption W_d is calculated by the following equation, where the operating voltage in the CPU section is V_d and the average current consumption is I_{Normal} .

$$W_d = V_d \cdot I_{Normal}$$

Under the intermittent operation, the average power consumption W_d is calculated by the following equations, where the operating voltage is V_d , and the average current consumption is I_{Int} .

$$I_{Int} = \frac{I_{Ope} \cdot T_{Ope} + I_{Standby} \cdot T_{Standby}}{T_{Ope} + T_{Standby}}$$

$$W_d = V_d \cdot I_{Int}$$

Under the same intermittent operation, the average power consumption is W_a calculated by the following equation, where the operating voltage in the AFE section is V_a , the average current consumption is I_{A-int} .

$$I_{A-Int} = \frac{I_{A-Ope} \cdot T_{A-Ope} + I_{A-Standby} \cdot T_{A-Standby}}{T_{A-Ope} + T_{A-Standby}}$$

$$W_a = V_a \cdot I_{A-Int}$$

The total of average power consumption $W_{Intermittent}$ is as follows:

$$W_{Intermittent} = W_d + W_a$$

Since intermittent operation can reduce the average current consumption (blue line) than normal operation, the power consumption is smaller when operating with the same voltage.

4.2.2 Voltage Measurement

The pin input voltage is calculated from the A/D conversion result. Assuming the PGA setting gain G_{PGA} , the full-scale of A/D conversion 2^{24} , and the DSAD reference voltage V_{REF} , the relation of the input pin voltage V for the A/D conversion result DATA is expressed by the following formula.

$$V = \frac{2 \cdot V_{REF}}{2^{24} \cdot G_{PGA}} \cdot DATA$$

5. Sample Program

5.1 Overview of Operation

Figure 5-1 shows the process flow of this sample program.

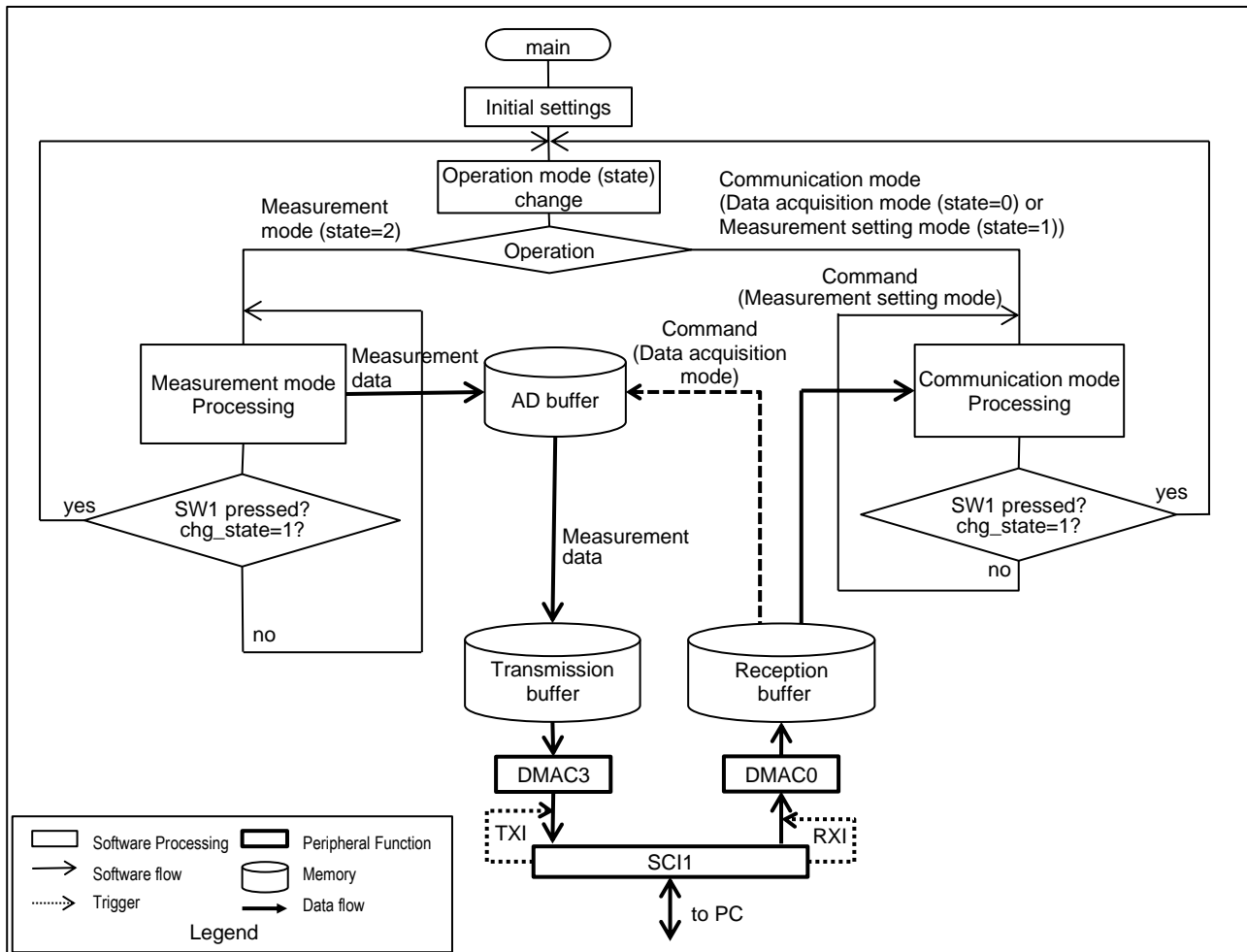

Figure 5-1 General Flow

This system has three operating modes: one measurement mode and two communication modes (data acquisition mode and measurement setting mode). You can change the operation mode by pressing SW1 of RSSK. In the data acquisition mode and measurement setting mode, you can use the PC Tool Program to acquire data or change measurement condition settings.

When using PC Tool Program, it should be connected to RSSKRX23E-A beforehand. For details about how to use PC Tool Program, refer to the Application Note "RSSKRX23E-A PC Tool Program Operation Manual".

DSAD0 and LPT settings in measurement operation are configured with Smart Configurator (SC) and executed at initialization of the program execution (before shifting to the measurement mode).

The following provides an overview of each of the processes.

- Initial setting
- Performs the following initial settings.
 - Operation mode initialization (Default setting: Data acquisition mode)
 - LED1 initial setting
 - SW1 chattering prevention setting (CMT1 setting)

- Measurement mode
 - Measurement mode initial setting
 - A/D Conversion

- Communication mode
 - Communication mode initial setting
 - Received packet processing
 - Packet transmission processing
 - Data packet creation
 - Measurement condition settings (set with PC Tool Program)
 - Measurement data transmission
 - Calibration implementation

5.2 Functions and Settings of MCU Used

Table 5-1 lists the peripheral functions used in this example, and Table 5-2 lists the pins used. Table 5-3 lists the clock settings.

The settings for peripheral functions are generated by using the code generation function of Smart Configurator.

Table 5-1 Peripheral functions used

Peripheral functions	Use
AFE, DSAD0	Input signal A/D conversion
CMT0	Generates LED blinking interval
CMT1	SW1 Chattering suppression
DMAC0	Packet reception from PC Tool Program
DMAC3	Packet transmission to PC Tool Program
ELC	Generates A/D conversion start trigger in combination with LPT
ICU	Interrupt control when switch is pressed (IRQ3) External trigger input to start A/D conversion (IRQ4)
LPT	Generates measurement interval for intermittent operation
PB1	Measurement interval selection (H: 1sec, L: 5min)
PH0	Clears the measurement result buffer (AD buffer) H: Normal, L: Clear
PH2	LED control
SCI1	Communication with PC Tool Program

Table 5-2 Pins used

Pin No.	Pin name	I/O	Use	
			Measurement mode	Communication mode
14	RXD1/P30	I	Hi-Z ^{Note}	Reception data input pin
15	IRQ3/P27	I	SW1 input pin	
16	TXD1/P26	O	Hi-Z	Transmission data output pin
22	PH2	O	LED1 output pin	
24	PH0	I	Hi-Z	Data acquisition mode: Delete the number of measurement data
29	PB1	I	LPT cycle selection, Hi-Z after selection	Hi-Z
31	IRQ4/PB0	I	IRQ4 input pin	Hi-Z
39	AIN0	I	DSAD0 analog input pin (-)	
40	AIN1	I	DSAD0 analog input pin (+)	

Note: Hi-Z : high impedance

Table 5-3 Clock settings

Item	Setting
Clock used	LOCO clock (4MHz)
	IWDT-dedicated low-speed clock (15kHz)
SCKCR (ICLK)	x1/4 (1MHz)
SCKCR (PCLKB)	x1/4 (1MHz)
Low power timer clock (LPTCLK)	15 (kHz)
DSAD0 modulator clock frequency (f _{MOD})	x1/8 (0.125MHz)

5.2.1 Voltage Measurement

DSAD0 is used to measure voltage. When the measurement trigger is the on-chip timer, LPT and ELC are used to return CPU from software standby. The peripheral function settings are shown below.

Table 5-4 DSAD0 settings

Item	Setting	
Analog input channel setting	Channel 0	
Δ - Σ A/D Converter operation voltage setting	2.7V~5.5V	
Δ - Σ A/D Converter operation mode setting	Low-power mode	
Operation clock setting	PCLKB(1MHz)	
Conversion start trigger setting	Start trigger source	Software trigger
Interrupt setting	Enable Δ - Σ A/D conversion completion interrupt (ADIO)	Enabled Priority Level15 (highest)
	Enable Δ - Σ A/D conversion scan completion interrupt (SCANENDIO)	Disabled
Inter-unit synchronized start setting	Enable synchronized start	Not set
Voltage fault and disconnection detection setting	Enable reference voltage fault detection	Not set
	Enable positive input signal voltage fault detection	Not set
	Enable negative input signal voltage fault detection	Not set
Channel 0 Tab		
Analog input setting	Positive input signal	AIN1
	Negative input signal	AIN0
	Reference input	REFOUT/AVSS0
Amplifier setting	Amplifier selection	PGA
	PGA gain setting	x1
Δ - Σ A/D conversion setting	A/D conversion mode	Normal operation
	Data format	Two's complement
	A/D conversion number	1 Exponential operation mode (the number of A/D conversion is from 1 to 8032)
	Oversampling ratio	Other ratio
	OSRm register value	77 1248 (100SPS)
	Set offset calibration value	Not set
	Set gain calibration value	Not set
	Enable averaging data	Not set
Disconnect detection assist setting	Not set	

Table 5-5 LPT settings

Item	Setting	
Low-power timer operation setting	Clock source	IWDT-dedicated on-chip oscillator
	Frequency	1/16, 0.938 (kHz)
Compare match setting	Timer cycle value	60000ms
	Register (LPTPRD)	56249
	Compare value 0	56248

Table 5-6 ELC settings

Item		Setting
Source	Configuration	Config_LPT
	Resource	LPT
	Event	LPT compare match
Destination	Configuration	Config_ELC
	Resource	LPT dedicated interrupt
	Operation	Issue LPT compare match interrupt request
	Priority	Level 15 (highest)
Port group and single-port setting	Setting	Not set

5.2.2 Communication

SCI1, DMAC, and ICU are used for communication with PC Tool Program. The settings for each peripheral function are shown below.

Table 5-7 SCI1 settings

Item		Setting
Start bit edge detection setting		Low level on RXD1 pin
Data length setting		8 bits
Parity setting		None
Stop bit length setting		1 bit
Transfer direction setting		LSB-first
Instant transmission setting	Enable instant transmission	Unchecked
Transfer rate setting	Transfer clock	Internal clock
	Bit rate	31250 (bps)
	Enables bit rate modulation function	Checked
	SCK1 pin function	SCK1 is not used.
Noise filter setting		Not used
Hardware flow control setting		None
Data handling setting	Transmit data handling	Data handled by DMAC
	Receive data handling	Data handled by DMAC
Interrupt setting	Enables reception error interrupt	Not used
	TXI1,RXI1,TEI1,ERI1 priority	Level 15 (highest)
Multiple interrupts setting		Not used
Callback function setting		Not used

Table 5-8 DMAC settings

Item		Setting	
		DMAC0	DMAC3
Transfer setting	Activation source	SCI1(TX11)	SCI1(TX11)
	Activation source flag control	Clear interrupt flag of the activation source	
	Transfer mode	Free running mode	Normal mode
	Transfer data size	8 bits	
	Transfer count / Repeat size / Block size	-	1
	Total transfer size		1 byte
Source address setting	Source address	0x0008A025 Fixed	0x00000000 Incremented (Set at runtime by software)
	Specify the transfer source as extended repeat area	-	Enabled
	Extended repeat area		Lower 12 bits of the address (4K bytes)
	Start address of expanded repeat area		0x00000000 (Set at runtime by software)
	End address of expanded repeat area		0x00000000 (Set at runtime by software)
Destination address setting	Destination address	0x00000000 Incremented (Set at runtime by software)	0x0008A023 Fixed
	Specify the transfer destination as extended repeat area	Enabled	-
	Extended repeat area	Lower 9 bits of the address (512 bytes)	
	Start address of expanded repeat area	0x00000000 (Set at runtime by software)	
	End address of expanded repeat area	0x00000000 (Set at runtime by software)	
Interrupt setting		Not used	

5.2.3 I/O Ports and Interrupt Controller Settings

Table 5-9 I/O Ports settings

Item	Setting		
Port selection	PORT1	PORT2	PORT3
Used port	Apply to all	Apply to all	Apply to all
Setting	Unused GPIO Pull-up: Unchecked CMOS output High-drive output: Unchecked	Unused GPIO Pull-up: Unchecked CMOS output High-drive output: Unchecked	Unused GPIO Pull-up: Unchecked CMOS output High-drive output: Unchecked

Item	Setting		
Port selection	PORTB		PORTC
Used port	PB0	PB1	Apply to all
Setting	Unused GPIO Pull-up: Unchecked CMOS output High-drive output: Unchecked	In Pull-up: Unchecked High-drive output: Unchecked	Unused GPIO Pull-up: Unchecked CMOS output High-drive output: Unchecked

Item	Setting	
Port selection	PORTH	
Used port	PH0, PH1, PH3	PH2
Setting	Unused GPIO Pull-up: Unchecked CMOS output High-drive output: Unchecked	Out CMOS output Output 1: Checked High-drive output: Unchecked

Table 5-10 ICU settings

Item	Setting	
Software interrupt setting	Software interrupt	Unchecked
NMI pin interrupt setting	NMI pin interrupt	Unchecked
IRQ0 setting	IRQ0	Unchecked
IRQ1 setting	IRQ1	Unchecked
IRQ2 setting	IRQ2	Unchecked
IRQ3 setting	IRQ3	Checked
	Detection type	Low level
	Digital filter	PCLK/64
	Priority	Level 15 (highest)
IRQ4 setting	IRQ4	Checked
	Detection type	Rising edge
	Digital filter	No filter
	Priority	Level 15 (highest)
IRQ5 setting	IRQ5	Unchecked
IRQ6 setting	IRQ6	Unchecked
IRQ7 setting	IRQ7	Unchecked

5.2.4 LED and Switch

Use CMT to prevent SW1 chattering and control LED ON/OFF. The following shows the settings for each peripheral function.

Table 5-11 CMT Settings

Item	Setting		
	CMT0	CMT1	
Use	Generates LED1 blinking interval	Prevents SW1 chattering	
Count clock setting	PCLK/8		
Compare match setting	Interval value	250ms	100ms
	Compare match interrupt (CMI0, CMI1)	Checked	
	Enables multiple interrupt (CMI0, CMT1)	Unchecked	
	Priority	Level 15 (highest)	Level 0 (disabled)

5.3 Measurement Mode

Figure 5-2 shows the processing steps of the measurement mode.

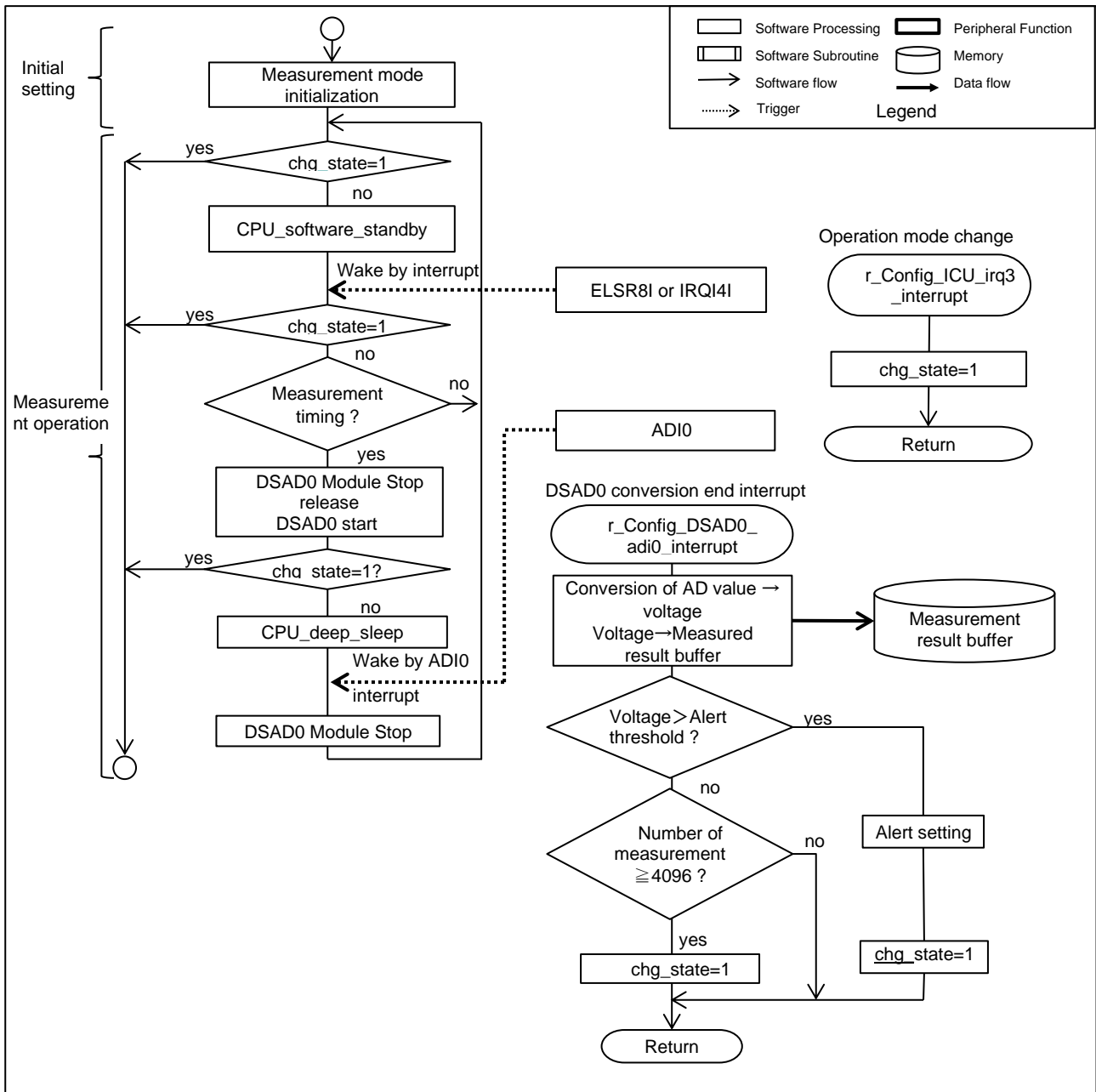

Figure 5-2 Processing steps in measurement mode

The overview of the measurement mode is as follows.

Measurement mode initial setting

— Perform initial settings shown in Table 5-12.

Table 5-12 Measurement mode initial settings

Item	Value	Description
I/O port setting	–	P27(IRQ3) and PB0(IRQ4) ^{Note} : interrupt input All of other I/O ports: input (Hi-Z)
DSAD operation setting	False	Disables DSAD0 and DSAD1 (module stop state)
DMAC0, DMAC3 setting	False	Disables DMAC0 and DMAC3 (module stop state)
SCI1 setting	False	Disables SCI1 (module stop state)
CMT0 setting	False	Disables CMT0 (module stop state)

Note: In case of using external input as a measurement trigger. If using the on-chip timer, this is an input (Hi-Z).

Measurement operation

- After performing the initial setting in the transition to the measurement mode, the CPU keeps software standby until A/D conversion is triggered by the external interrupt (IRQ4I) or the RX23E-A built-in timer LPT interrupt (ELSR8I). When using the LPT, since the LPT cannot generate interrupt directly, use ELSR8I interrupt that is generated by ELC on the LPT compare match event.
- The A/D conversion value is stored in the memory after voltage conversion. If the converted voltage exceeds the threshold voltage set by the user, an alert is displayed (LED is turned on), the system stops measuring and automatically shifts to the Data acquisition mode. In the same way, if the number of measurement data exceeds 4096, the system stops measuring and automatically shifts to the Data acquisition mode. Otherwise, the measurement continues until SW1 is pressed.

5.4 Communication Mode

Figure 5-3 shows the processing steps of the communication mode.

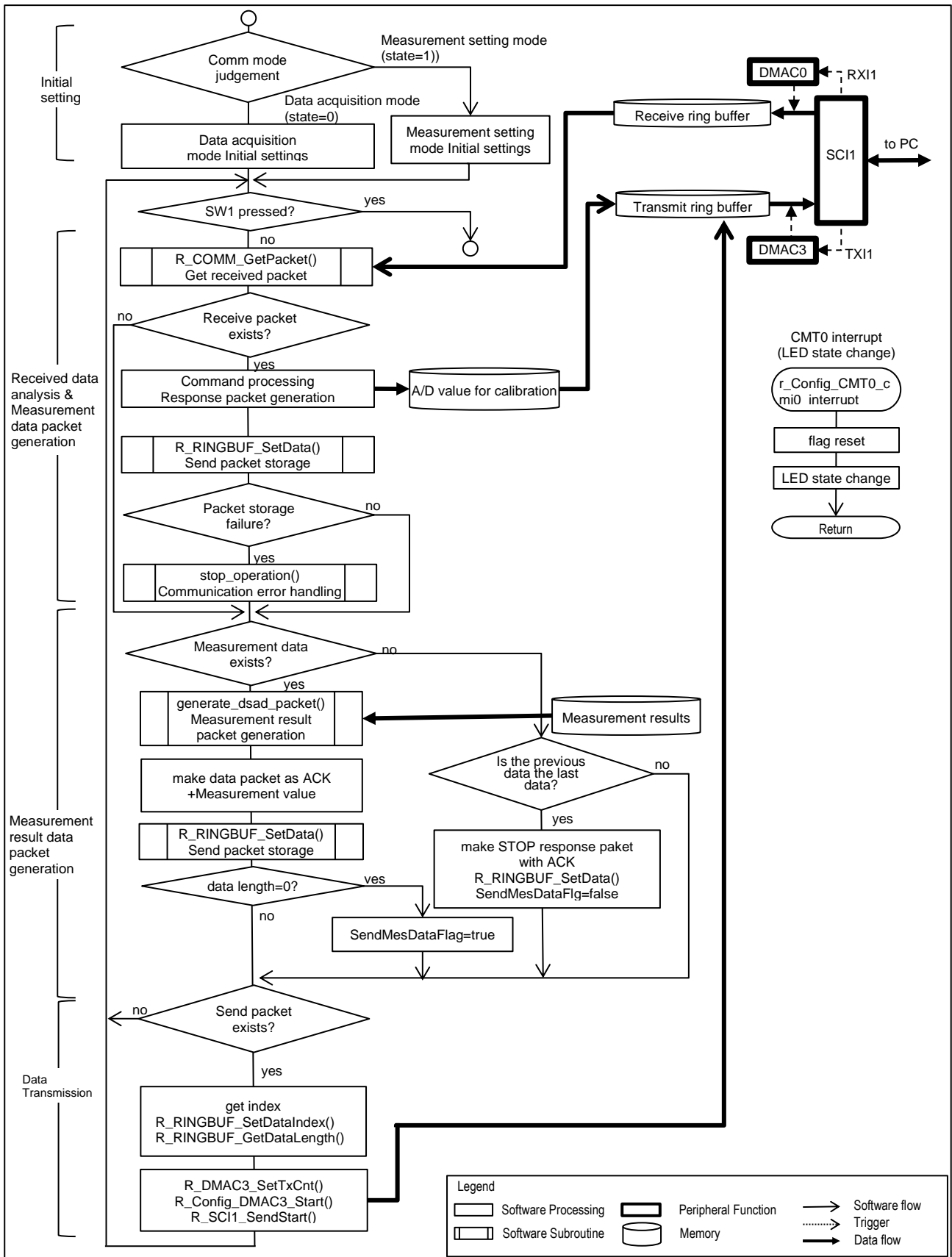

Figure 5-3 Communication mode processing steps

The overview of each process is as follows.

Communication mode initial setting

— Table 5-13 lists the initial setting items in the communication mode.

Table 5-13 Communication mode initial settings

Item	Value	Description
I/O port setting	-	Sets I/O ports for the communication mode P26(TXD1), P30(RXD1), P27(IRQ3), PB0(High impedance), PH2(LED1)
DSAD0 operation setting	True	Enables DSAD0 setting
DSAD0 operation mode and ADI0 setting	False	DSAD0 operation mode: low-power mode Disables ADI0
DMAC0,DMAC3	True	Enables DMAC0 and DMAC3
SCI1 setting	True	Enables SCI1
CMT0 setting	True	Enables CMT0
LED operation setting	State	Used in the communication mode State = 0 or 1 0: Blinking at 250ms interval 1: Blinking at 500ms interval

Receive packet processing

— Obtains a reception packet from the receive ring buffer, analyzes the command, processes accordingly, and stores a response packet in the transmit ring buffer. Table 5-14 lists the commands supported by this program and the processes corresponding to the command. Returns a NAKC for a command that is not supported. If a response packet cannot be stored in the transmit ring buffer, processes a communication error.

Table 5-14 Response packet handled and processed

Command	Operating mode	
	Data acquisition mode (state=0)	Measurement setting mode (state=1)
Negotiation	Measurement value	DSAD value (ch0 only)
Read	AFE, DSAD register values	
Write	-	Sets AFE, DSAD register values
Run	All measured data	Starts DSAD0, A/D value,...A/D value
Stop	Stops sending measurement data	Stops DSAD
Version	Version character string	
User value	Sets an alert threshold value (ALM_THRESH)	-

Measured data packet generation

— If the measured result transmission enabled flag is set AND if there is an update of measured value, creates a transmission packet of measured value and stores it in the transmit ring buffer.

If a response packet cannot be stored in the transmit ring buffer, processes a communication error.

Packet transmission process

— When data is not under transmission and if there is an un-transmitted data in the transmit ring buffer, starts transmission with DMAC3.

Executing calibration

— Executes calibration. Please refer to the RSSKRX23E-A PC Tool Program Operation Manual (R20AN0540EJ0201) for details.

5.5 Program Configuration

5.5.1 File Configuration

Table 5-15 File configuration (1/2)

Item	Description
src	
└smc_gen	Smart Configurator generation
├─Config_CMT0	
│ │ └Config_CMT0.c	
│ │ └Config_CMT0.h	
│ │ └─Config_CMT0_user.c	
├─Config_CMT1	
│ │ └Config_CMT1.c	
│ │ └Config_CMT1.h	
│ │ └─Config_CMT1_user.c	
├─Config_DMAC0	
│ │ └Config_DMAC0.c	
│ │ └Config_DMAC0.h	
│ │ └─Config_DMAC0_user.c	
├─Config_DMAC3	
│ │ └Config_DMAC3.c	
│ │ └Config_DMAC3.h	
│ │ └─Config_DMAC3_user.c	
├─Config_DSAD0	
│ │ └Config_DSAD0.c	
│ │ └Config_DSAD0.h	
│ │ └─Config_DSAD03_user.c	
├─Config_ELC	
│ │ └Config_ELC.c	
│ │ └Config_ELC.h	
│ │ └─Config_ELC_user.c	
├─Config_ICU	
│ │ └Config_ICU.c	
│ │ └Config_ICU.h	
│ │ └─Config_ICU_user.c	
├─Config_LPT	
│ │ └Config_LPT.c	
│ │ └Config_LPT.h	
│ │ └─Config_LPT_user.c	
├─Config_PORT	
│ │ └Config_PORT.c	
│ │ └Config_PORT.h	
│ │ └─Config_PORT_user.c	

Table 5-16 File configuration (2/2)

Item	Description
src	
Config_SCI1	Smart Configurator generation
Config_SCI1.c	
Config_SCI1.h	
Config_SCI1_user.c	
general	
r_bsp	
r_config	
r_pincfg	
r_main.c	
r_communication_control_api.c	Communication control program
r_communication_control_api.h	Communication control API definition
r_ring_buffer_control_api.c	Ring buffer control program
r_ring_buffer_control_api.h	Ring buffer control API definition
r_userdata.h	User definition
HardwareDebug-IRQ4— rx23ea_lowpower_fw_for_rssk.mot	Compiled object file (Measurement trigger: external input)
HardwareDebug-LPT— rx23ea_lowpower_fw_for_rssk.mot	Compiled object file (Measurement trigger: on-chip timer)

5.5.2 Macro Definitions

Table 5-17 main.c setting list

Definition name	Value	Description
D_CMD_THRSH_MIN	0.0F	Voltage alert threshold value (lower limit)
D_CMD_THRSH_MAX	10.0F	Voltage alert threshold value (upper limit)
D_INITIAL_VOLTAGE_ERR_THRESHOLD	10.0F	Voltage alert initial value
D_DSAD_2VREF	5.0F	DSAD0 full-scale voltage (=Vref x 2)
D_DSAD_FULL_ADVAL	16777216.0F	DSAD0 full AD value (= 2 ²⁴)
D_LONG_INT_CNT	5	Minutes count number for long interval
IRQ4EN	-	When defined (default setting), trigger source is LPT. When not defined, trigger source is IRQ4. For how to change, refer to Table 1-3.

Table 5-18 r_userdata.h setting list

Definition name	Value	Description
D_MAX_DATA_CNT	4096	Largest number of stored measurement result

Table 5-19 Config_CMT0.h setting list

Definition name	Value	Description
_F423_CMT0_CMCOR_VALUE	0xF423U	LED blinking interval: 500ms
_7A11_CMT0_CMCOR_VALUE	0x7A11	LED blinking interval: 250ms

Table 5-20 Config_LPT.c and Config_LPT.h setting list

Definition name	Value	Description
_0752_LPT_LPTPRD_VALUE	0x0752	1-sec cycle measurement
_0751_LPT_LPCMR0_VALUE	0x0751	Compare match timer for 1-sec cycle measurement
_DBB9_LPT_LPTPRD_VALUE	0xDBB9	5-min cycle measurement
_DBB8_LPT_LPCMR0_VALUE	0xDBB8	Compare match timer for 5-min cycle measurement

5.5.3 Structures and Unions

Table 5-21 r_userdata.h: enumerated type list

Enum name	e_state_t	
Description	Mode status management	
Member	Name	Description
	E_GETTING_DATA	Data acquisition mode, 0
	E_SET_REGISTERS	Measurement setting mode, 1
	E_MEASUREMENT	Measurement mode, 2
	E_MODE	Limiter

Table 5-22 r_userdata.h: structures list

Structure Type name	st_params_t		
Description	Parameter information		
Member	Type	Name	Description
	e_state_t	state	Operating mode state variables
	uint8_t	chg_state	Status change flag
	uint8_t	lpt_5min	LPT timer use setting flag 0: 1-second measurement, 1: 5-minutes measurement
	uint32_t	lp_cntr	Software counter for 5-minutes measurement
	bool	dsad_average	Average number of A/D conversions
	float	v_conversion_coef	A/D value voltage conversion formula
	float	alm_thresh	Voltage alarm threshold level setting
	bool	alm_err	Alarm occurrence flag True: Alarm occurred False: No abnormality
	bool	send_mes_data_flag	Measurement data transmission flag True: Send data False: Do not send data
Structure Type name	st_mesdata_t		
Description	Measurement data information		
Member	Type	Member	Type
	int32_t	d_number	Measurement data index
	int32_t	sd_index	Send data index
	float	data	Measurement data

5.5.4 Functions

Table 5-23 main.c function

Function name	main			
Description	Main function			
Argument	I/O	Type	Name	Description
	—	void	-	-
Return value	O	void	-	-

Function name	analysis_packet			
Description	Processes command and creates response packet			
Argument	I/O	Type	Name	Description
	I	uint8_t	rcv_pkt[]	Reception packet (receive command)
	O	uint8_t	send_pkt[]	Transmission packet (response packet)
	O	bool	*p_flag	true=DSAD is running, false=DSAD is stopped
Return value	-	static size_t	Number of characters stored in send_pkt	

Function name	generate_dsad_packet			
Description	Generates DSAD data packet			
Argument	I/O	Type	Name	Description
	I	uint8_t	unit	DSAD unit number selection: 0 or 1
	O	uint8_t	send_pkt[]	Generated DSAD data packet
	O	uint32_t	data	A/D conversion result
Return value	-	static size_t	Number of characters stored in send_pkt	

Function name	generate_measurement_packet			
Description	Generates voltage measured value data packet			
Argument	I/O	Type	Name	Description
	O	uint8_t	send_pkt[]	Generated measurement data packet
	I	float	data	Measurement value
Return value	-	static void	Number of characters stored in send_pkt	

Function name	stop_operation			
Description	Stops transmission at transmission error and initializes buffer			
Argument	I/O	Type	Name	Description
	O	st_ring_buf_t	*ary	Pointer to transmission buffer to be set to DMAC3
Return value	-	static void	-	

Function name	cpu_software_standby			
Description	Shifts CPT into software standby mode			
Argument	I/O	Type	Name	Description
	-	void	-	-
Return value	-	void	-	

Function name	cpu_deep_sleep			
Description	Shifts CPT into Deep sleep mode			
Argument	I/O	Type	Name	Description
	-	void	-	
Return value	-	void	-	

Table 5-24 r_communication_control_api.c function

Function name	R_COMM_GetPacket			
Description	Gets character string of specified length from ring buffer			
Argument	I/O	Type	Name	Description
	I	st_ring_buf_t	*r_buf	Pointer to receive ring buffer
	O	uint8_t	r_packet[]	Reception packet
Return value	-	size_t	Number of characters got	

Function name	R_RINGBUF_GetData			
Description	Sets character string of specified length to ring buffer			
Argument	I/O	Type	Name	Description
	O	float	*data	Pointer to voltage measurement value
	I	st_mesdata_t	*st_mdata	Pointer to measurement value structure
Return value	-	bool	true=data exists, false=data not exists	

Table 5-25 r_ring_buffer_control_api.c function

Function name	R_RINGBUF_GetData			
Description	Gets character string of specified length from ring buffer			
Argument	I/O	Type	Name	Description
	I	st_ring_buf_t	*ary	Pointer to ring buffer
	O	uint8_t	data[]	Character strings got
	I	size_t	len	Number of characters to be got
	I	bool	index_update	Enables/disables update the position to get character string (true=enabled)
Return value	-	size_t	Number of characters got	

Function name	R_RINGBUF_SetData			
Description	Sets character string of specified length to ring buffer			
Argument	I/O	Type	Name	Description
	O	st_ring_buf_t	*ary	Pointer to ring buffer
	I	uint8_t	data[]	Character string to be set
	I	size_t	len	Number of characters to be set
Return value	-	size_t	Number of characters set	

Function name	R_RINGBUF_GetDataLength			
Description	Gets number of characters stores in ring buffer			
Argument	I/O	Type	Name	Description
	I	st_ring_buf_t	*ary	Pointer to ring buffer
Return value	-	size_t	Number of characters stored	

Function name	R_RINGBUF_SetDataIndex			
Description	Updates ring buffer index			
Argument	I/O	Type	Name	Description
	I	st_ring_buf_t	*ary	Pointer to ring buffer
	I	uint32_t	value	Index value to be set
	I	uint8_t	select	Setting target: 0=Read index, 1=Write index
Return value	-	uint32_t	Set value	

Function name	R_RINGBUF_InitRcvBuffer			
Description	Initializes transmission/reception ring buffer			
Argument	I/O	Type	Name	Description
	I	st_ring_buf_t	*in_ary	Pointer to receive ring buffer
Return value	-	void	-	

Table 5-26 Config_DMACH0.c function

Function name	R_DMACH0_SetDestAddr			
Description	Sets transfer destination address to DMACH0			
Argument	I/O	Type	Name	Description
	I	void	*p_addr	Destination address
Return value	I	void	-	

Table 5-27 Config_DMACH3.c function

Function name	R_DMACH3_SetSrcAddr			
Description	Sets transfer source address to DMACH3			
Argument	I/O	Type	Name	Description
	I	void	*p_addr	Source address
Return value	-	void	-	

Function name	R_DMACH3_SetTxCnt			
Description	Sets number of transmission characters to DMACH3			
Argument	I/O	Type	Name	Description
	I	uint32_t	cnt	Number of characters to be transferred
Return value	-	void	-	

Function name	R_DMACH_Activate			
Description	Enables/disables (module stop) DMACH0 and DMACH3			
Argument	I/O	Type	Name	Description
	I	bool	flag	True=enabled, false=disabled (module stop)
Return value	-	void	-	

Table 5-28 Config_DSAD0.c function

Function name	R_DSAD0_Start_NoIEN			
Description	Starts DSAD0 operation			
Argument	I/O	Type	Name	Description
	-	void	-	-
Return value	-	void	-	-

Function name	R_DSAD0_GetData			
Description	Returns DSAD0 A/D conversion result			
Argument	I/O	Type	Name	Description
	O	uint32_t	*data	Pointer to A/D conversion result
Return value	-	bool	true=Got A/D conversion result, false=Cannot get.	

Function name	R_DSAD0_LP_Configure			
Description	DSAD0 operating mode and ADI0 enable/disable setting			
Argument	I/O	Type	Name	Description
	I	bool	flag	true=low power, false=communication mode
Return value	-	void	-	-

Table 5-29 Config_DSAD0_user.c function

Function name	R_Config_DSAD0_Create_UserInit			
Description	Initializes the gain correction register and offset correction register (GCR0, OFCR0) of DSAD0 Releases the DSAD1 module stop and initializes the CCR.			
Argument	I/O	Type	Name	Description
	-	void	-	-
Return value	-	void	-	-

Function name	R_DSAD_Activate			
Description	Enables/disables (module stop) DSAD0 and DSAD1			
Argument	I/O	Type	Name	Description
	I	bool	act_flag0	true=DSAD0 enabled, false=disabled (module stop)
Return value	I	bool	act_flag1	true=DSAD1 enabled, false=disabled (module stop)
Return value	-	void	-	-

Function name	r_Config_DSAD0_adi0_interrupt			
Description	Converts DSAD0 A/D conversion result at measurement mode into voltage and stores it in memory (g_mdata)			
Argument	I/O	Type	Name	Description
	-	void	-	-
Return value	-	void	-	-

Table 5-30 Config_ICU_user.c function

Function name	R_Config_ICU_irq3_interrupt			
Description	Changes RSSK operating state			
Argument	I/O	Type	Name	Description
	-	void	-	-
Return value	-	void	-	-

Table 5-31 Config_PORT.c function

Function name	R_PORT_LP_Configure			
Description	Sets I/O port for low-power operation or communication			
Argument	I/O	Type	Name	Description
	l	bool	lp_flag	true=low power, false=communication mode
Return value	-	void	-	-

Table 5-32 Config_CMT0_user.c function

Function name	r_Config_CMT0_cmi0_interrupt			
Description	Blinks LED1			
Argument	I/O	Type	Name	Description
	l	Void	-	-
Return value	-	static void	-	-

Table 5-33 Config_CMT0.c function

Function name	R_Config_CMT0_SetLEDInterval			
Description	Set LED1 blinking interval			
Argument	I/O	Type	Name	Description
	l	uint32_t	state	0=com mode2, 1=com mode1
Return value	-	void	-	-

Function name	R_CMT0_Activate			
Description	Enables/disables (module stop) CMT0			
Argument	I/O	Type	Name	Description
	l	bool	flag	True=enabled, false=disabled (module stop)
Return value	-	void	-	-

Table 5-34 Config_CMT1.c function

Function name	R_CMT1_Activate			
Description	Enables/disables (module stop) CMT1			
Argument	I/O	Type	Name	Description
	l	bool	flag	True=CMT1 is active, false=module stop
Return value	-	void	-	-

Table 5-35 Config_SCI1.c function

Function name	R_SCI1_IsTransferEnd			
Description	Returns transmission completion state of SCI1			
Argument	I/O	Type	Name	Description
	I	void	-	-
Return value	-	bool	true=transmission is completed, false=transmission is not completed	

Function name	R_SCI1_SendStart			
Description	Starts SCI1 transmission			
Argument	I/O	Type	Name	Description
	I	void	-	-
Return value	-	MD_STATUS	Returns MD_OK(0x00)	

Function name	R_SCI1_SendStop			
Description	Stops SCI1 transmission			
Argument	I/O	Type	Name	Description
	I	void	-	-
Return value	-	MD_STATUS	Returns MD_OK(0x00)	

Function name	R_SCI1_ReceiveStart			
Description	Starts SCI1 reception			
Argument	I/O	Type	Name	Description
	I	Void	-	-
Return value	-	MD_STATUS	Returns MD_OK(0x00)	

Function name	R_Config_SCI1_Activate			
Description	Enables or disables (module stop) SCI1			
Argument	I/O	Type	Name	Description
	I	bool	flag	true=enabled, false=disabled (module stop)
Return value	-	void	-	

Table 5-36 Config_LPT.c function

Function name	R_LPT_SetInterval			
Description	Sets LPT cycle to 1 sec or 5 minutes			
Argument	I/O	Type	Name	Description
	I	uint8_t	sec_flag	1: 1sec, 0: 5minutes
	I/O	st_params_t	*params	Pointer to params structure
Return value	-	void	-	

6. Import a Project

After importing the sample project, make sure to confirm build and debugger setting. This chapter shows how to import projects into e² studio and CS+. After the import is completed, check your build and debug settings.

6.1 Importing a Project into e² studio

Follow the steps below to import your project into e² studio. Pictures may be different depending on the version of e² studio to be used)

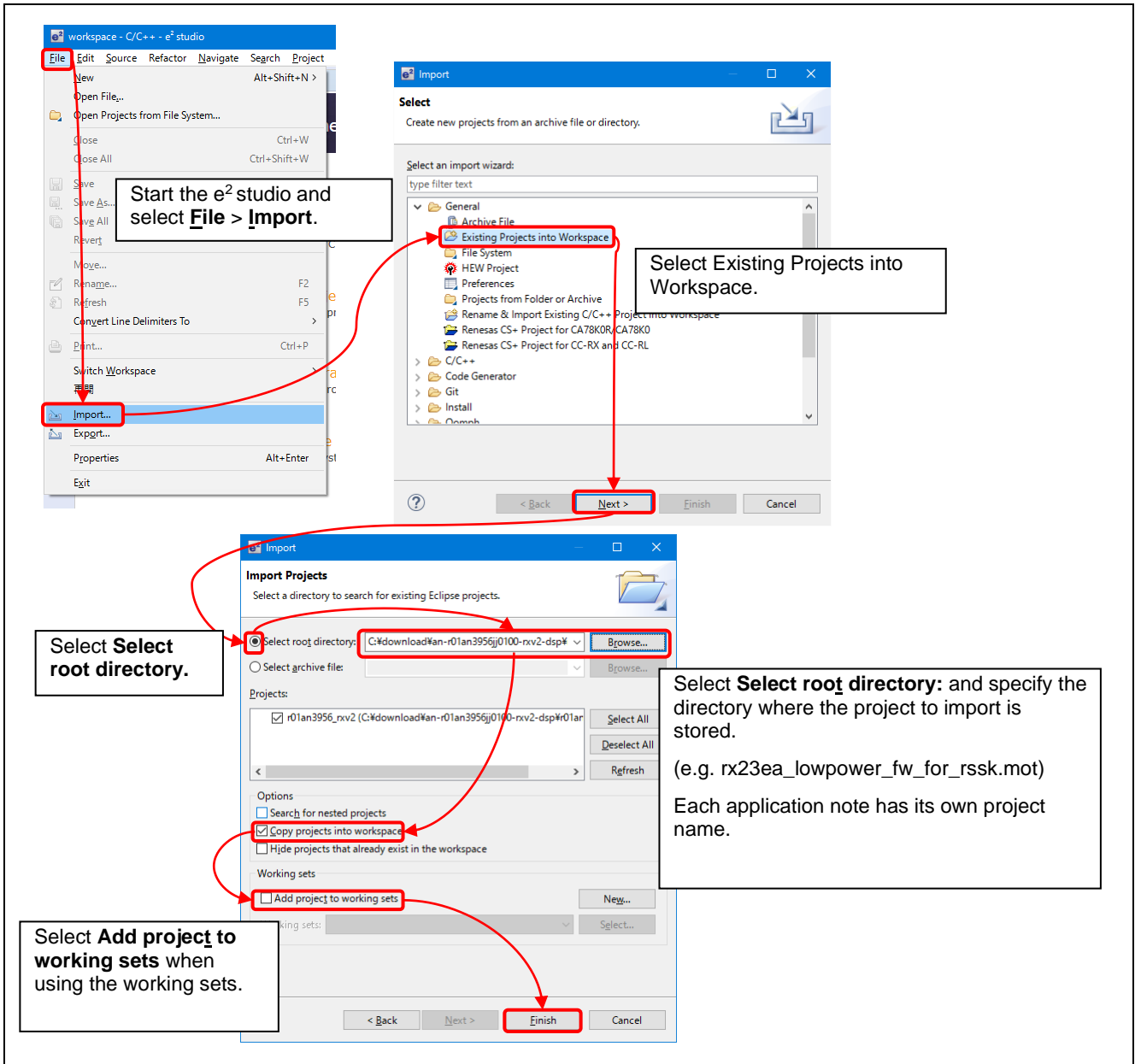

Figure 6-1 Importing a project into e2 studio

6.2 Importing a Project into CS+

Follow the steps below to import your project into CS+. Pictures may be different depending on the version of CS+ to be used.

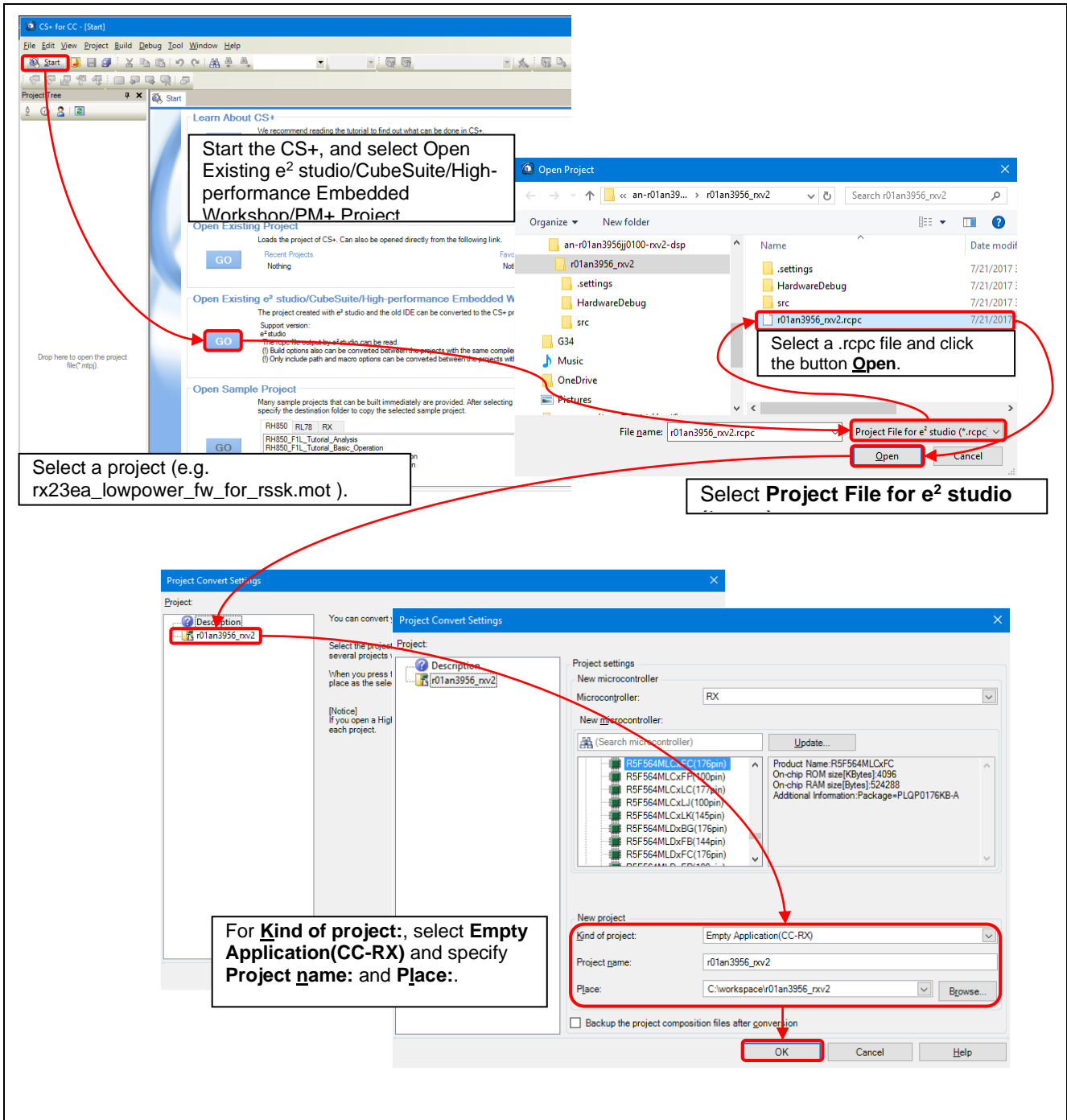

Figure 6-2 Importing a project into CS+

7. Measurement Result Using Sample Program

7.1 Memory Usage

7.1.1 Build Conditions

Table 7-1 shows the build conditions for the sample program.

Table 7-1 Build Conditions

Item	Setting
Compiler	'-isa=rsv2 -include=(include path) -utf8 -nomessage -output=obj -obj_path=\${workspace_loc}/\${ProjName}/\${ConfigName}} -outcode=utf8 -nologo
Linker	-noprelink -output="rx23ea_lowpower_fw_for_rssk.abs" -form=absolute -nomessage -vect=_undefined_interrupt_source_isr -list -nooptimize -rom=D=R,D_1=R_1,D_2=R_2 -cpu=RAM=00000000-00007fff, FIX=00080000-00083fff, FIX=00086000-00087fff, FIX=00088000-0008dfff, FIX=00090000-0009ffff, FIX=000a0000-000bffff, FIX=000c0000-000fffff, ROM=00100000-00101fff, FIX=007fc000-007fc4ff, FIX=007ffc00-007fffff, ROM=fffc0000-ffffffffff -stack -nologo

7.1.2 Memory Usage

The amount of memory usage of sample program is shown in Table 7-2.

Table 7-2 Amount of Memory Usage

Item	Usage amount [Byte]
ROM	32871
Code	14630
Data	18241
RAM	28590 (23626)
Data	23470
Stack	5120 (156)

Note: RAM usage shown in "(")" is calculated from stack usage.

7.1.3 Execution Cycle and Processing Time in Measurement Mode

Table 7-3 shows the numbers of CPU execution cycles and each processing time in the measurement mode of the sample program.

Table 7-3 Number of execution cycles and processing time

ICLK=1MHz

Item	Maximum number of execution cycles (execution time)
Interrupt processing	8 cycles (8μs)
A/D value acquisition processing	10 cycles (10μs)
A/D voltage conversion and result storage processing	12 cycles (12μs)
Buffer overflow and alert judgement processing	22 cycles (22μs)
total	52 cycles (52μs)

7.2 Evaluation Condition

Using the sample program, we evaluated the power consumption and resolution. The configuration of low-power consumption evaluation is shown in Figure 7-1, the equipment used for measurement is shown in Table 7-4, the measurement conditions are shown in Table 7-5 and the calibration conditions are shown in Table 7-6.

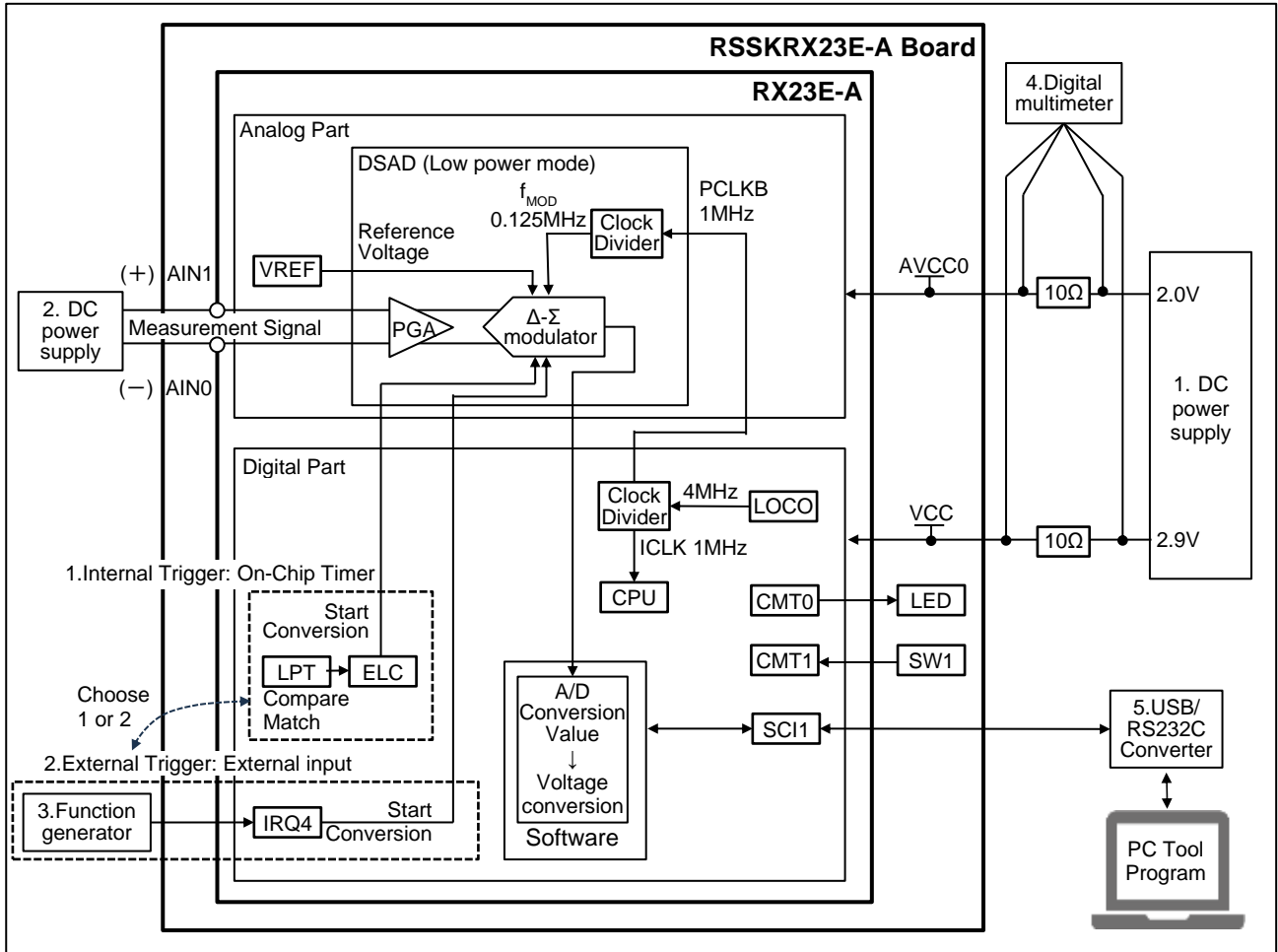

Figure 7-1 RX23E-A configuration of low power consumption evaluation

Table 7-4 List of equipment

No	Equipment	Model	Manufacturer name	Remarks
1	DC power supply	PA14A1	ShibaSoku Co., Ltd.	Power supply for VCC and AVCC0
2	DC power supply	TR6243	ADVANTEST CORPORATION.	Used for calibration
3	Function generator	33120A	Keysight Technologies	Measurement trigger: used for external input
4	Digital multimeter	34465A, 3458A	Keysight Technologies	For current consumption measurement
5	USB-RS232C conversion board	AE-UM232R	AKIZUKI DENSHI TSUSHO CO., LTD.	For connection to PC tool program ^{Note}

Note: The supply voltage of the FT232's VCCIO is changed to 2V using an external LDO to match the system's 2V I/O voltage level.

Table 7-5 Measurement conditions

Items	Settings
Supply Voltage	VCC: 2.0V, AVCC0: 2.9V
Condition	PGA gain: x1, Sampling rate:100sps,Average number of A/D conversions:1, Measurement interval: 1s
Temperature	Room temperature

Table 7-6 Calibration conditions

PGA Gain value	Reference Voltage 1	Reference Voltage 2
1	0.000V	2.400V

7.3 Evaluation Results

In this evaluation, we measured current consumption and the short noise in Table 7-5 condition settings by making short circuit with analog input pins AIN0 and AIN1. The results of current consumption, power consumption and effective resolution in RX23E-A of AFE section and CPU section are shown in Table 7-7, Table 7-8, and Table 7-9. In addition, Figure 7-2 shows a trend graph of current consumption using an external trigger.

For the AFE section, the current consumption is reduced by stopping the AFE module during standby. The stop of the AFE module is achieved by shutting off the power supply and clock supply to the AFE section. At this time, the current flowing through AVCC0 corresponds to the 'AVCC0 power down current'. In this system, we got the result of less than 0.1 μ A in actual measurement. During A/D conversion operation, the operating mode of the DSAD0 is set to low-power mode to reduce current consumption.

For the CPU section, minimizes the CPU operating time and reduces current consumption by shifting to software standby mode during standby, and shifting deep sleep mode during A/D conversion for measurement.

Table 7-7 Current consumption measurement result

	Current consumption [μ A]				
	AFE section		CPU section		
	Module stop	AFE active	Software Standby	Deep sleep	CPU WakeUp
External Input	less than 0.1	405.3	0.7	279.3	550.4
On-Chip Timer	less than 0.1	399.0	0.7	280.8	565.9
Reference	2.2 Max ^{Note1}	DSAD: 380 Typ VREF: 45 Typ Total: 425 Typ ^{Note2}	0.4 Typ ^{Note3}	-	-

Notes: 1. RX23E-A Group User's Manual: Hardware Table 39.15.

2. RX23E-A Group User's Manual: Hardware Table 39.14.

3. RX23E-A Group User's Manual: Hardware Table 39.9.

Table 7-8 Power consumption measurement result

Trigger	AFE section power consumption [mW]	CPU section power consumption [mW]	Total [mW]
External Input	0.005	0.002	0.007
On-Chip Timer	0.005	0.002	0.007

Table 7-9 Effective resolution measurement result

Trigger	RMS noise [μ V _{rms}] (Effective resolution (bits))
External Input	4.642 (20.04)
On-Chip Timer	4.532 (20.07)
Reference	4.794 (20.00) ^{Note}

Note: RX23E-A Group User's Manual: Hardware Table 39.55, Table 39.56.

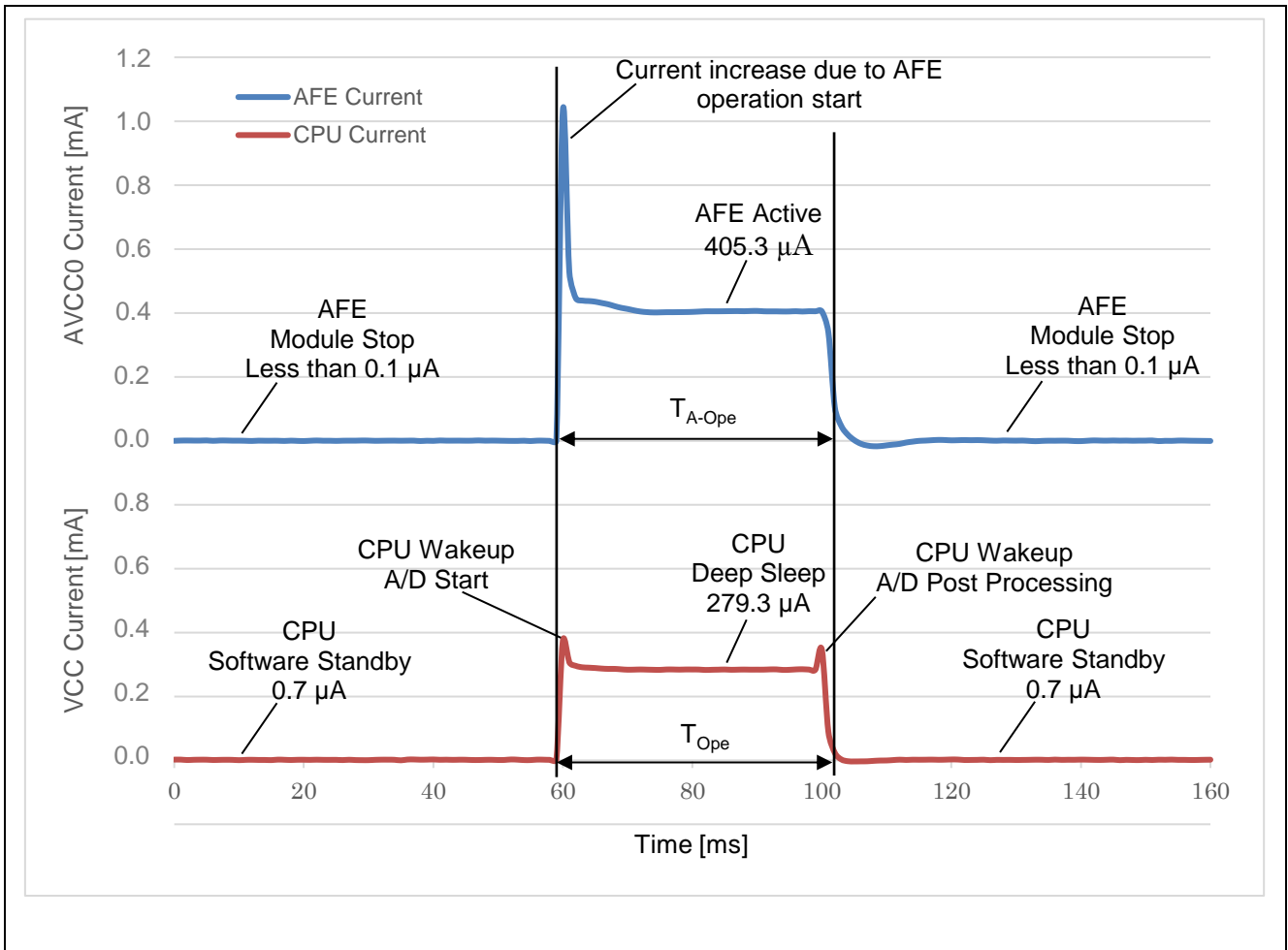

Figure 7-2 Current consumption measurement result (External trigger)

Revision History

Rev.	Date	Description	
		Page	Summary
1.0	Jan.29.25	-	First edition.

General Precautions in the Handling of Microprocessing Unit and Microcontroller Unit Products

The following usage notes are applicable to all Microprocessing unit and Microcontroller unit products from Renesas. For detailed usage notes on the products covered by this document, refer to the relevant sections of the document as well as any technical updates that have been issued for the products.

1. Precaution against Electrostatic Discharge (ESD)

A strong electrical field, when exposed to a CMOS device, can cause destruction of the gate oxide and ultimately degrade the device operation. Steps must be taken to stop the generation of static electricity as much as possible, and quickly dissipate it when it occurs. Environmental control must be adequate. When it is dry, a humidifier should be used. This is recommended to avoid using insulators that can easily build up static electricity.

Semiconductor devices must be stored and transported in an anti-static container, static shielding bag or conductive material. All test and measurement tools including work benches and floors must be grounded. The operator must also be grounded using a wrist strap. Semiconductor devices must not be touched with bare hands. Similar precautions must be taken for printed circuit boards with mounted semiconductor devices.

2. Processing at power-on

The state of the product is undefined at the time when power is supplied. The states of internal circuits in the LSI are indeterminate and the states of register settings and pins are undefined at the time when power is supplied. In a finished product where the reset signal is applied to the external reset pin, the states of pins are not guaranteed from the time when power is supplied until the reset process is completed. In a similar way, the states of pins in a product that is reset by an on-chip power-on reset function are not guaranteed from the time when power is supplied until the power reaches the level at which resetting is specified.

3. Input of signal during power-off state

Do not input signals or an I/O pull-up power supply while the device is powered off. The current injection that results from input of such a signal or I/O pull-up power supply may cause malfunction and the abnormal current that passes in the device at this time may cause degradation of internal elements. Follow the guideline for input signal during power-off state as described in your product documentation.

4. Handling of unused pins

Handle unused pins in accordance with the directions given under handling of unused pins in the manual. The input pins of CMOS products are generally in the high-impedance state. In operation with an unused pin in the open-circuit state, extra electromagnetic noise is induced in the vicinity of the LSI, an associated shoot-through current flows internally, and malfunctions occur due to the false recognition of the pin state as an input signal become possible.

5. Clock signals

After applying a reset, only release the reset line after the operating clock signal becomes stable. When switching the clock signal during program execution, wait until the target clock signal is stabilized. When the clock signal is generated with an external resonator or from an external oscillator during a reset, ensure that the reset line is only released after full stabilization of the clock signal. Additionally, when switching to a clock signal produced with an external resonator or by an external oscillator while program execution is in progress, wait until the target clock signal is stable.

6. Voltage application waveform at input pin

Waveform distortion due to input noise or a reflected wave may cause malfunction. If the input of the CMOS device stays in the area between V_{IL} (Max.) and V_{IH} (Min.) due to noise, for example, the device may malfunction. Take care to prevent chattering noise from entering the device when the input level is fixed, and also in the transition period when the input level passes through the area between V_{IL} (Max.) and V_{IH} (Min.).

7. Prohibition of access to reserved addresses

Access to reserved addresses is prohibited. The reserved addresses are provided for possible future expansion of functions. Do not access these addresses as the correct operation of the LSI is not guaranteed.

8. Differences between products

Before changing from one product to another, for example to a product with a different part number, confirm that the change will not lead to problems. The characteristics of a microprocessing unit or microcontroller unit products in the same group but having a different part number might differ in terms of internal memory capacity, layout pattern, and other factors, which can affect the ranges of electrical characteristics, such as characteristic values, operating margins, immunity to noise, and amount of radiated noise. When changing to a product with a different part number, implement a system-evaluation test for the given product.

Notice

1. Descriptions of circuits, software and other related information in this document are provided only to illustrate the operation of semiconductor products and application examples. You are fully responsible for the incorporation or any other use of the circuits, software, and information in the design of your product or system. Renesas Electronics disclaims any and all liability for any losses and damages incurred by you or third parties arising from the use of these circuits, software, or information.
2. Renesas Electronics hereby expressly disclaims any warranties against and liability for infringement or any other claims involving patents, copyrights, or other intellectual property rights of third parties, by or arising from the use of Renesas Electronics products or technical information described in this document, including but not limited to, the product data, drawings, charts, programs, algorithms, and application examples.
3. No license, express, implied or otherwise, is granted hereby under any patents, copyrights or other intellectual property rights of Renesas Electronics or others.
4. You shall be responsible for determining what licenses are required from any third parties, and obtaining such licenses for the lawful import, export, manufacture, sales, utilization, distribution or other disposal of any products incorporating Renesas Electronics products, if required.
5. You shall not alter, modify, copy, or reverse engineer any Renesas Electronics product, whether in whole or in part. Renesas Electronics disclaims any and all liability for any losses or damages incurred by you or third parties arising from such alteration, modification, copying or reverse engineering.
6. Renesas Electronics products are classified according to the following two quality grades: "Standard" and "High Quality". The intended applications for each Renesas Electronics product depends on the product's quality grade, as indicated below.
 - "Standard": Computers; office equipment; communications equipment; test and measurement equipment; audio and visual equipment; home electronic appliances; machine tools; personal electronic equipment; industrial robots; etc.
 - "High Quality": Transportation equipment (automobiles, trains, ships, etc.); traffic control (traffic lights); large-scale communication equipment; key financial terminal systems; safety control equipment; etc.Unless expressly designated as a high reliability product or a product for harsh environments in a Renesas Electronics data sheet or other Renesas Electronics document, Renesas Electronics products are not intended or authorized for use in products or systems that may pose a direct threat to human life or bodily injury (artificial life support devices or systems; surgical implantations; etc.), or may cause serious property damage (space system; undersea repeaters; nuclear power control systems; aircraft control systems; key plant systems; military equipment; etc.). Renesas Electronics disclaims any and all liability for any damages or losses incurred by you or any third parties arising from the use of any Renesas Electronics product that is inconsistent with any Renesas Electronics data sheet, user's manual or other Renesas Electronics document.
7. No semiconductor product is absolutely secure. Notwithstanding any security measures or features that may be implemented in Renesas Electronics hardware or software products, Renesas Electronics shall have absolutely no liability arising out of any vulnerability or security breach, including but not limited to any unauthorized access to or use of a Renesas Electronics product or a system that uses a Renesas Electronics product. RENESAS ELECTRONICS DOES NOT WARRANT OR GUARANTEE THAT RENESAS ELECTRONICS PRODUCTS, OR ANY SYSTEMS CREATED USING RENESAS ELECTRONICS PRODUCTS WILL BE INVULNERABLE OR FREE FROM CORRUPTION, ATTACK, VIRUSES, INTERFERENCE, HACKING, DATA LOSS OR THEFT, OR OTHER SECURITY INTRUSION ("Vulnerability Issues"). RENESAS ELECTRONICS DISCLAIMS ANY AND ALL RESPONSIBILITY OR LIABILITY ARISING FROM OR RELATED TO ANY VULNERABILITY ISSUES. FURTHERMORE, TO THE EXTENT PERMITTED BY APPLICABLE LAW, RENESAS ELECTRONICS DISCLAIMS ANY AND ALL WARRANTIES, EXPRESS OR IMPLIED, WITH RESPECT TO THIS DOCUMENT AND ANY RELATED OR ACCOMPANYING SOFTWARE OR HARDWARE, INCLUDING BUT NOT LIMITED TO THE IMPLIED WARRANTIES OF MERCHANTABILITY, OR FITNESS FOR A PARTICULAR PURPOSE.
8. When using Renesas Electronics products, refer to the latest product information (data sheets, user's manuals, application notes, "General Notes for Handling and Using Semiconductor Devices" in the reliability handbook, etc.), and ensure that usage conditions are within the ranges specified by Renesas Electronics with respect to maximum ratings, operating power supply voltage range, heat dissipation characteristics, installation, etc. Renesas Electronics disclaims any and all liability for any malfunctions, failure or accident arising out of the use of Renesas Electronics products outside of such specified ranges.
9. Although Renesas Electronics endeavors to improve the quality and reliability of Renesas Electronics products, semiconductor products have specific characteristics, such as the occurrence of failure at a certain rate and malfunctions under certain use conditions. Unless designated as a high reliability product or a product for harsh environments in a Renesas Electronics data sheet or other Renesas Electronics document, Renesas Electronics products are not subject to radiation resistance design. You are responsible for implementing safety measures to guard against the possibility of bodily injury, injury or damage caused by fire, and/or danger to the public in the event of a failure or malfunction of Renesas Electronics products, such as safety design for hardware and software, including but not limited to redundancy, fire control and malfunction prevention, appropriate treatment for aging degradation or any other appropriate measures. Because the evaluation of microcomputer software alone is very difficult and impractical, you are responsible for evaluating the safety of the final products or systems manufactured by you.
10. Please contact a Renesas Electronics sales office for details as to environmental matters such as the environmental compatibility of each Renesas Electronics product. You are responsible for carefully and sufficiently investigating applicable laws and regulations that regulate the inclusion or use of controlled substances, including without limitation, the EU RoHS Directive, and using Renesas Electronics products in compliance with all these applicable laws and regulations. Renesas Electronics disclaims any and all liability for damages or losses occurring as a result of your noncompliance with applicable laws and regulations.
11. Renesas Electronics products and technologies shall not be used for or incorporated into any products or systems whose manufacture, use, or sale is prohibited under any applicable domestic or foreign laws or regulations. You shall comply with any applicable export control laws and regulations promulgated and administered by the governments of any countries asserting jurisdiction over the parties or transactions.
12. It is the responsibility of the buyer or distributor of Renesas Electronics products, or any other party who distributes, disposes of, or otherwise sells or transfers the product to a third party, to notify such third party in advance of the contents and conditions set forth in this document.
13. This document shall not be reprinted, reproduced or duplicated in any form, in whole or in part, without prior written consent of Renesas Electronics.
14. Please contact a Renesas Electronics sales office if you have any questions regarding the information contained in this document or Renesas Electronics products.

(Note1) "Renesas Electronics" as used in this document means Renesas Electronics Corporation and also includes its directly or indirectly controlled subsidiaries.

(Note2) "Renesas Electronics product(s)" means any product developed or manufactured by or for Renesas Electronics.

(Rev.5.0-1 2020.10)

Corporate Headquarters

TOYOSU FORESIA, 3-2-24 Toyosu,
Koto-ku, Tokyo 135-0061, Japan
www.renesas.com

Trademarks

Renesas and the Renesas logo are trademarks of Renesas Electronics Corporation. All trademarks and registered trademarks are the property of their respective owners.

Contact information

For further information on a product, technology, the most up-to-date version of a document, or your nearest sales office, please visit:
www.renesas.com/contact/.