

### RX23E-A Group

### Temperature Measurement Example Using a Thermocouple

#### Summary

This document describes a temperature measurement example with a thermocouple, using RX23E-A.

RX23E-A contains analog front-end (AFE) and 24-bit  $\Delta$ - $\Sigma$  A/D converter (DSAD). Using the programmable gain instrumentation amplifier (referred to as PGA in the remainder of this manual), bias voltage generator (referred to as VBIAS), etc., high-precision A/D conversion is performed on the output of the thermocouple to calculate the temperature.

Temperature measurement was performed with K thermocouple, using Renesas Solution Starter Kit for RX23E-A and sample program included in this document. Error of temperature measurement result is shown below.

Measurement range :	-40°C ~150°C
Board temperature :	-40°C, Room temperature (about 25°C), 85°C
Effective resolution :	19.4bit (57.4nVrms: 1.5m°C equivalent)
Noise free resolution :	16.8bit (335.4nV: 8.6m°C equivalent)

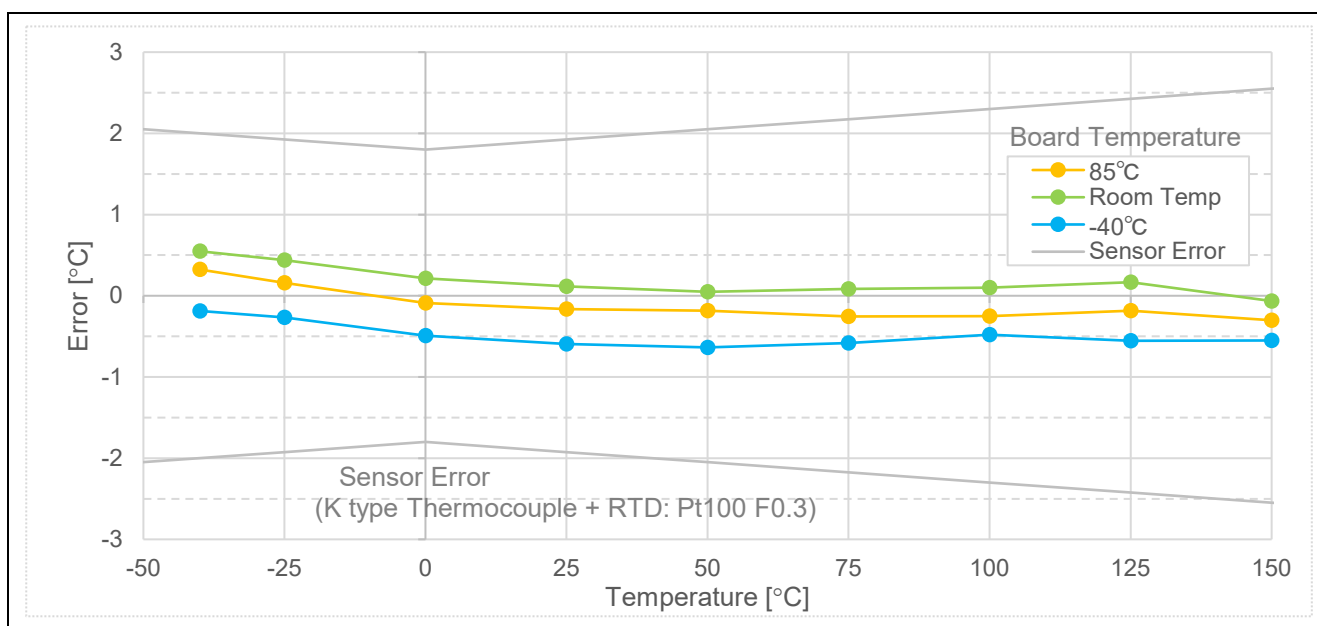

#### Target Device

RX23E-A

## Contents

1. Overview .....	3
2. Related Documents .....	3
3. Environment for Operation Confirmation .....	3
4. Temperature Measurement System .....	4
4.1 Temperature Measurement Using a Thermocouple .....	5
4.1.1 Thermocouple .....	5
4.1.2 Resistance Temperature Detector (RTD) .....	6
4.2 Temperature Calculation Procedure .....	7
4.3 Other Functions .....	9
4.3.1 Calibration .....	9
4.3.2 50Hz/60Hz Noise Reduction .....	9
4.3.3 AIN Chopping .....	9
4.3.4 Linkage with the PC Tool Program .....	9
5. Sample Program .....	10
5.1 Overview of Operation .....	10
5.2 Peripheral Functions and Pins Used .....	11
5.2.1 AFE, DSAD0, and DSAD1 .....	12
5.2.2 SCI1, DMAC0, DMAC3, and CMT0 .....	13
5.2.3 PH2 .....	14
5.3 Communication Control .....	15
5.4 Program Configuration .....	17
5.4.1 File Configuration .....	17
5.4.2 Macro Definitions .....	18
5.4.3 Structure .....	18
5.4.4 Functions .....	18
6. Importing a Project .....	23
6.1 Importing a Project into e <sup>2</sup> studio .....	23
6.2 Importing a Project into CS+ .....	24
7. Measurement Results with Sample Program .....	25
7.1 Memory Usage and Number of Execution Cycle .....	25
7.1.1 Build Conditions .....	25
7.1.2 Memory Usage .....	25
7.1.3 The Number of Execution Cycle .....	25
7.2 Temperature Measurement .....	26
7.2.1 Measurement Condition .....	26
7.2.2 Calibration .....	26
7.2.3 Measurement results .....	27
Revision History .....	28

### 1. Overview

This document explains a temperature measurement example using a thermocouple, with RX23E-A. The sample program runs on the Renesas Solution Starter Kit for RX23E-A (RSSKRX23E-A) board, and the measurement results can be displayed with the PC tool program of RSSKRX23E-A.

In this example, the resistance temperature detector (RTD) mounted on the board is used for reference junction compensation. The temperature measurement system in this example is shown in Figure 1-1.

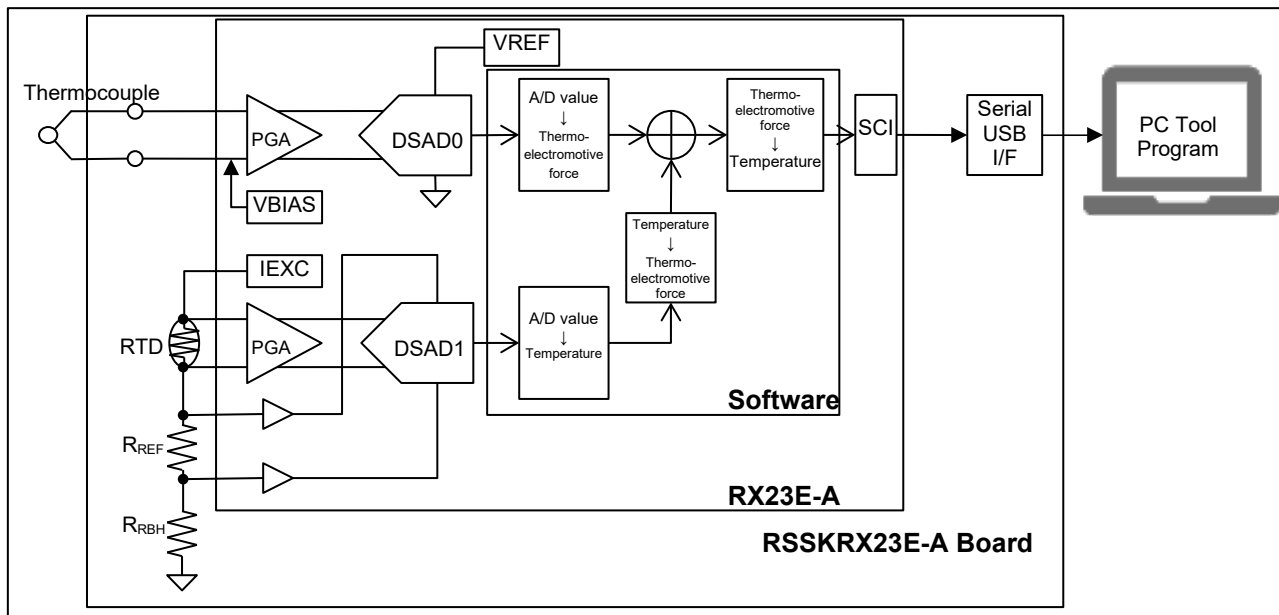

Figure 1-1 Temperature Measurement System Using the RSSKRX23E-A Board and a Thermocouple

### 2. Related Documents

- R01UH0801 RX23E-A Group User's Manual
- R20UT4542 RSSKRX23E-A User's Manual
- R20AN0540 Application Note RSSKRX23E-A PC Tool Program Operation Manual
- R01AN4788 Application Note RX23E-A Group Temperature Measurement Examples Using Resistance Temperature Detectors
- R01AN4799 Application Note RX23E-A Group Effective Use of AFE and DSAD

### 3. Environment for Operation Confirmation

The environment for operation confirmation is given in Table 3-1.

Table 3-1 Environment for Operation Confirmation

Item	Description
Board	RSSKRX23E-A board (RTK0ESXB10C00001BJ)
MCU	RX23E-A (R5F523E6ADFL) Power voltage (VCC, AVCC0): 5V Operating frequency (ICLK): 32MHz Peripheral operating frequency (PCLKB): 32MHz DSAD operating frequency (f <sub>DR</sub> ): 4MHz DSAD modulator clock frequency (f <sub>MOD</sub> ): 0.5MHz
RTD (on board)	Vishay PTS060301B100RP100
Thermocouple	Labfacility Ltd XE-3505-001
IDE	Renesas e <sup>2</sup> studio V7.8.0 Renesas Smart Configurator V2.6.0
Tool Chain	Renesas CC-RX V3.02.00
Emulator	E2 Emulator Lite

### 4. Temperature Measurement System

A block diagram of a hardware system using the RSSKRX23E-A board is shown in Figure 4-1.

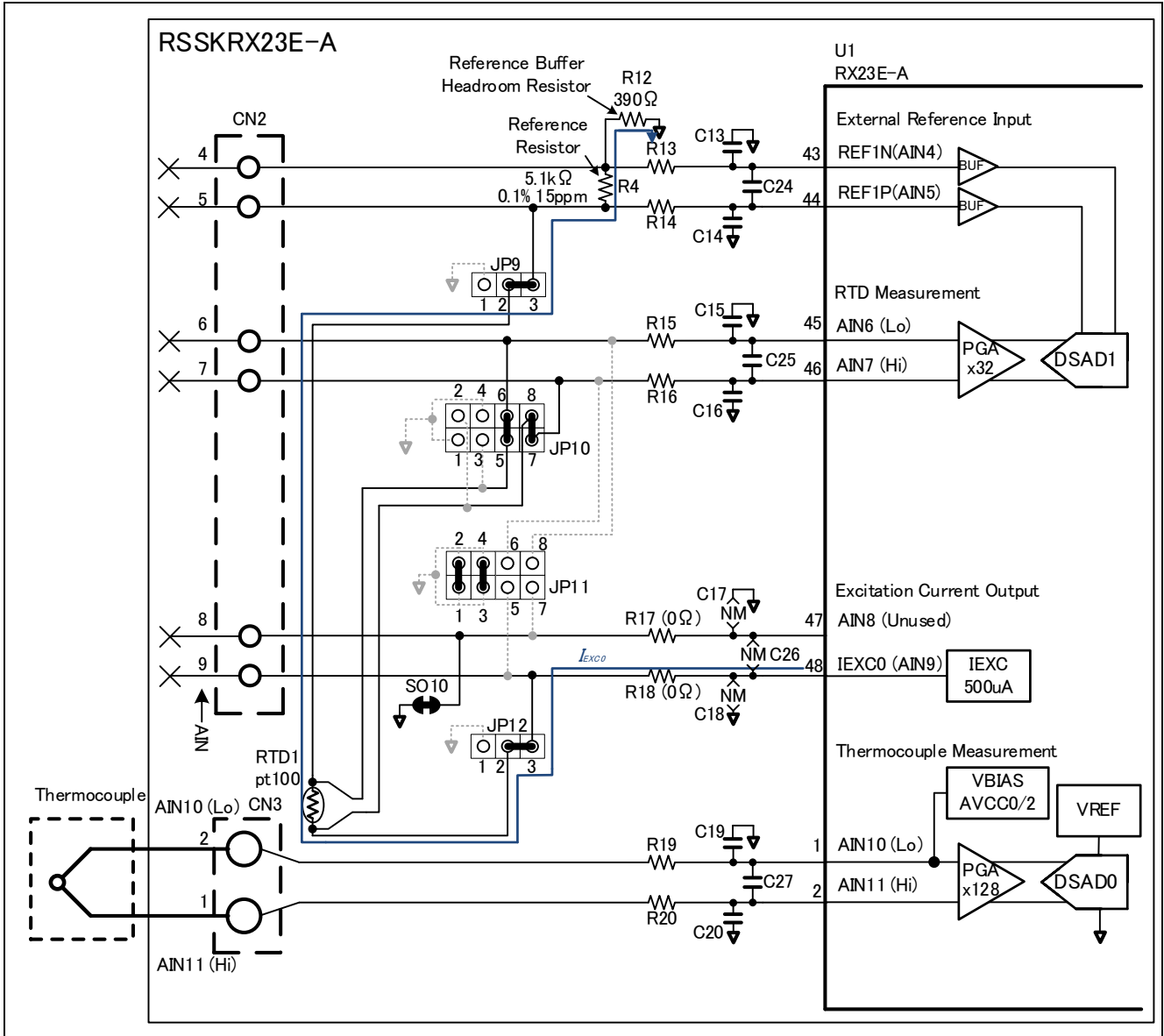

Figure 4-1 Block Diagram of the Hardware System

### 4.1 Temperature Measurement Using a Thermocouple

The thermocouple outputs a voltage (thermoelectromotive force) according to the temperature difference of the temperature measuring junction from the reference junction. In general, the following two techniques are used for conversion from voltage to temperature.

- Cold junction compensation: By setting the reference junction temperature of the thermocouple to 0°C, the thermoelectromotive force is converted to temperature.
- Reference junction compensation: The result of adding the thermoelectromotive force corresponding to the separately measured reference junction temperature to the thermoelectromotive force of the thermocouple is converted to temperature.

In this example, measurement is conducted with reference junction compensation. The reference junction temperature is the temperature measured with the RTD placed near the reference junction of the thermocouple on the RSSKRX23E-A board.

The following describes the thermocouple and the RTD used in this sample.

#### 4.1.1 Thermocouple

The specifications of the thermocouple XE-3583-001 used in this example are listed in Table 4-1 and the temperature vs. output voltage characteristics are shown in Figure 4-2.

Table 4-1 Excerpt of the XE-3505-001 Specifications

Item	Description
Type	K
Tolerance	IEC-584-2 Class 1
Temperature range	-75°C to +250°C
Output voltage range	-2,755uV to 10,153uV (junction reference Temperature: 0°C)

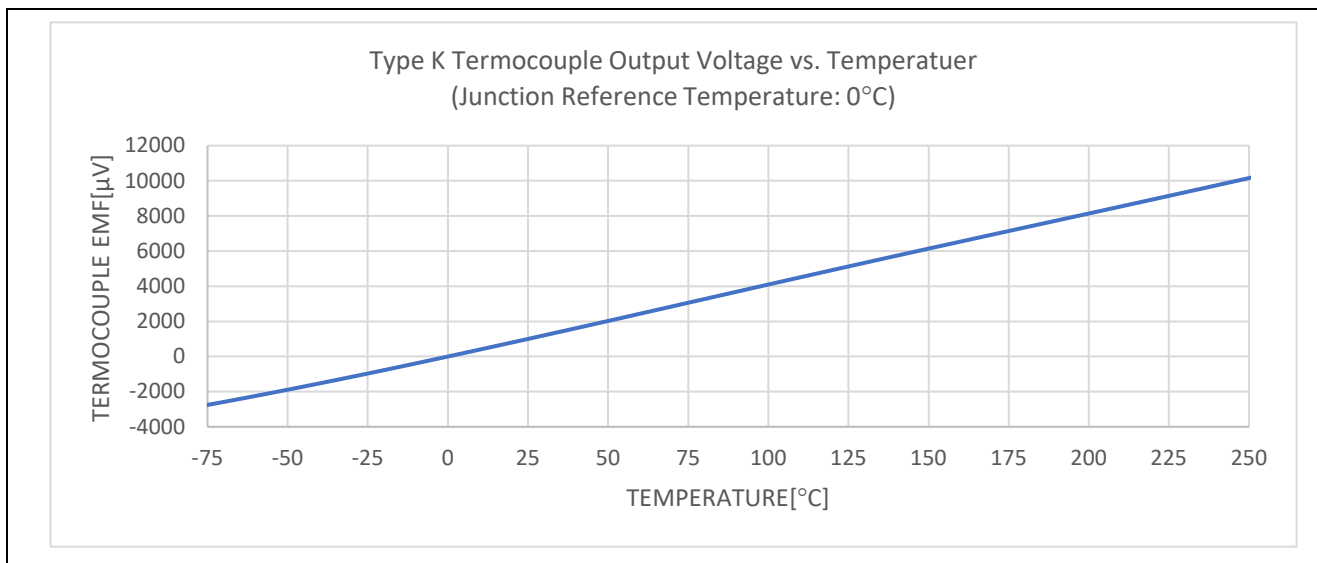

Figure 4-2 Type K Thermocouple Temperature Characteristics (from IEC 60584-1)

The thermocouple outputs positive and negative values as thermoelectromotive force, and is operated by supplying a bias voltage.

The thermocouple has non-linear thermoelectromotive force in relation to temperature, so that thermoelectromotive force is converted to temperature, using a table specifying thermoelectromotive force in relation to temperature. This example refers to the thermocouple reference table type K according to IEC 60584-1, and according to the thermocouple measurement temperature range, uses, in a range of -75°C to 251°C, a thermoelectromotive force table in increments of 1°C.

The thermocouple electromotive force measurement conditions in this example are listed in Table 4-2. If the oversampling ratio is not a power of two, the digital filter of the DSAD generates a gain of x1/2 to x1. The A/D conversion value is treated as having been multiplied by the above-mentioned gain.

Table 4-2 Thermocouple Measurement Conditions

Item	Condition	Remarks
Bias voltage	2.5 V	RX23E-A VBIAS is applied to the Lo side.
DSAD reference voltage $V_{REF0}$	2.5 V	The internal VREF output is used.
PGA gain $G_{PGA0}$	x128	
Oversampling ratio $OSR_0$	50000	A/D conversion value output rate 10 SPS
Digital filter gain $G_{DF0}$	0.677626358	$G_{DF0} = 1/2^{(Ceil(4 \log_2 OSR_0) - 4 \log_2 OSR_0)}$
DSAD output format	2's Complement	

4.1.2 Resistance Temperature Detector (RTD)

In this example, the 4-wire RTD, PTS060301B100RP100, mounted on the RSSKRX23E-A board is used. An excerpt of the PTS060301B100RP100 specifications is given in Table 4-3 and the characteristics of the resistance value in relation to temperature are shown in Figure 4-3.

Table 4-3 Excerpt of the PTS060301B100RP100 Specifications

Item	Description
Tolerance Class	F0.3
Resistance values $R_0$ at 0°C	100Ω
Operating temperature range (Board constraints)	-40°C to +85°C
Register value range (Board constraints)	84.271Ω to 132.803Ω
Measurement current $I_{meas.}$ (DC) <sup>Note</sup>	0.1mA to 0.50mA

Note: Constant current when the self-heating is less than 0.1°C

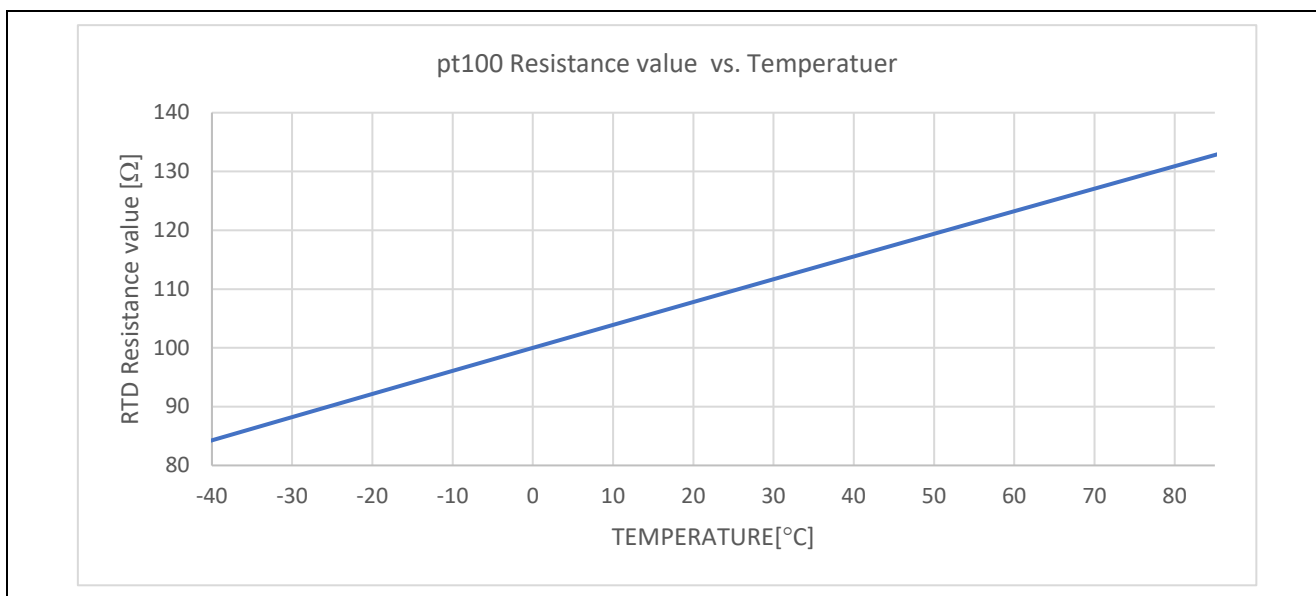

Figure 4-3 pt100 Temperature vs. Resistance Value (from IEC 60751)

This example conducts ratiometric measurement. To the RTD and the reference resistance  $R_{REF}$ , which are connected in series, constant current is applied, and with the voltage applied to  $R_{REF}$  as the reference voltage  $V_{REF1}$ , the voltage of the RTD is A/D converted.

From the A/D conversion value, the resistance value of the RTD is calculated, and the resistance value is converted to temperature. The resistance value of the RTD is non-linear in relation to temperature, so that the resistance value is converted to temperature, using a table specifying the resistance value in relation to temperature. From the Pt100Ω reference resistance value table of IEC 60751, and according to the operating range of RSSKRX23E-A, this example uses, in a range of -40°C to 86°C, a resistance value table in 1°C increments.

The RTD measurement conditions in this example are listed in Table 4-4. If the oversampling ratio is not a power of two, the digital filter of the DSAD generates a gain of x1/2 to x1. The A/D conversion value is treated as having been multiplied by the above-mentioned gain.

Table 4-4 RTD Measurement Conditions

Item	Condition	Remarks
Excitation current $I_{EXC}$	500uA	
PGA gain $G_{PGA1}$	x32	
Reference resistance value $R_{REF}$	5.1kΩ	
DSAD reference voltage $V_{REF1}$	2.55V	The voltage applied to $R_{REF}$ is assumed to be the A/D conversion reference voltage. $V_{REF1} = I_{EXC} \times R_{REF} = 2.55V$ Because of high impedance, a reference voltage buffer is used.
Oversampling ratio $OSR_1$	50000	A/D conversion value output rate 10SPS
Digital filter gain $G_{DF1}$	0.677626358	$G_{DF1} = 1/2^{(Ceil(4 \log_2 OSR_1) - 4 \log_2 OSR_1)}$
DSAD output format	2's Complement	

### 4.2 Temperature Calculation Procedure

The following describes the procedure for calculating temperature from each A/D conversion value, based on Figure 4-4.

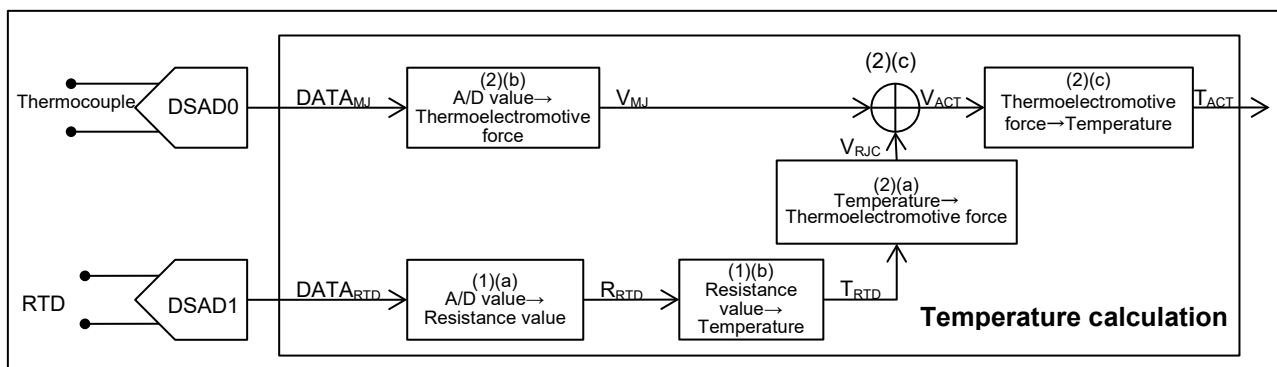

Figure 4-4 Temperature Calculation Procedure

(1) Thermocouple reference junction temperature measurement with the RTD

(a) RTD resistance value calculation

From the A/D conversion value  $DATA_{RTD}$  of the RTD, the resistance value  $R_{RTD}$  of the RTD is determined. Assuming that the set gain of the PGA is  $G_{PGA1}$ , the digital filter gain is  $G_{DF1}$ , the resolution of the DSAD is 24 bits, and the reference resistance value is  $R_{REF}$ ,  $R_{RTD}$  can be calculated with the formula below.

$$R_{RTD} = \frac{2 \cdot R_{REF}}{2^{24} \cdot G_{PGA1} \cdot G_{DF1}} \cdot DATA_{RTD} = \frac{R_{REF}}{2^{23} \cdot G_{PGA1} \cdot G_{DF1}} \cdot DATA_{RTD}$$

(b) Thermocouple reference junction temperature calculation

From the temperature vs. resistance value table for the RTD, the (temperatures, resistance values) before and after the resistance value  $R_{RTD}$  of the RTD are obtained, and from the obtained results, the temperature  $T_{RTD}$  equivalent to the resistance value  $R_{RTD}$  is determined with linear interpolation.

Assuming that the resistance value is R and the temperature is T, from the fact that the ratios of the distances from point a to measurement point c ( $T_{RTD}, R_{RTD}$ ) on the T-axis and the R-axis to the distances between two points a ( $T_1, R_1$ ) and b ( $T_2, R_2$ ) on the T-axis and the R-axis on the obtained table are the same, the relationship can be expressed with the formula below.

$$\frac{R_{RTD} - R_1}{R_2 - R_1} = \frac{T_{RTD} - T_1}{T_2 - T_1} = \alpha$$

The above formula is rearranged so that the temperature  $T_{RTD}$  for the resistance value  $R_{RTD}$  can be calculated with the formula below.

$$T_{RTD} = T_1 + \alpha(T_2 - T_1) = T_1 + \frac{R_{RTD} - R_1}{R_2 - R_1} \cdot (T_2 - T_1)$$

(2) Temperature calculation with thermocouple measurement

(a) Thermocouple reference junction thermoelectromotive force calculation

By assuming that the temperature  $T_{RTD}$  measured with the RTD is the reference junction temperature of the thermocouple, the (temperatures, thermoelectromotive forces) before and after the temperature  $T_{RTD}$  are obtained from the temperature vs. thermoelectromotive force table, and the thermoelectromotive force  $V_{RJC}$  equivalent to  $T_{RTD}$  is determined with linear interpolation.

Assuming that the temperature is  $T$  and the thermoelectromotive force is  $V$ , the thermoelectromotive force  $V_{RJC}$  for  $T_{RTD}$  on the line segment passing through two points  $(T_1, V_1)$  and  $(T_2, V_2)$  from the obtained table can be calculated with the formula below, based on the linear interpolation formula in (1)(b).

$$V_{RJC} = V_1 + \frac{T_{RTD} - T_1}{T_2 - T_1} \cdot (V_2 - V_1)$$

(b) Thermocouple temperature measuring junction thermoelectromotive force calculation

From the A/D conversion value  $DATA_{TC}$  of the thermocouple, the thermoelectromotive force  $V_{MJ}$  of the temperature measuring junction is determined. Assuming that the set gain of the PGA is  $G_{PGA0}$ , the digital filter gain is  $G_{DF0}$ , the full scale of the A/D conversion value is  $2^{24}$ , and the reference voltage of the DSAD is  $V_{REF0}$ , the temperature measuring junction thermoelectromotive force  $V_{MJ}$  can be calculated with the formula below.

$$V_{MJ} = \frac{2 \cdot V_{REF0}}{2^{24} \cdot G_{PGA0} \cdot G_{DF0}} \cdot DATA_{MJ} = \frac{V_{REF0}}{2^{23} \cdot G_{PGA0} \cdot G_{DF0}} \cdot DATA_{MJ}$$

(c) Calculation of the thermocouple thermoelectromotive force for the reference junction temperature 0°C

To the temperature measuring junction thermoelectromotive force  $V_{MJ}$ , the reference junction thermoelectromotive force  $V_{RJC}$  is added to calculate the thermocouple thermoelectromotive force  $V_{ACT}$  for the zero contact.

$$V_{ACT} = V_{MJ} + V_{RJC}$$

(d) Temperature conversion

From the temperature vs. thermoelectromotive force table, the (temperatures, electromotive forces) before and after the thermoelectromotive force  $V_{ACT}$  are obtained, and from the obtained results, the temperature  $T_{ACT}$  equivalent to  $V_{ACT}$  is determined with linear interpolation.

Assuming that the temperature is  $T$  and the thermoelectromotive force is  $V$ , the temperature  $T_{ACT}$  for the thermoelectromotive force  $V_{ACT}$  on the line segment passing through two points  $(T_1, V_1)$  and  $(T_2, V_2)$  from the obtained table can be calculated with the formula below, based on the linear interpolation formula in (1)(b).

$$T_{ACT} = T_1 + \frac{V_{ACT} - V_1}{V_2 - V_1} \cdot (T_2 - T_1)$$



## 4.3 Other Functions

### 4.3.1 Calibration

By increasing the precision of the correspondence between input voltage and A/D conversion value, measurement is improved. The DSAD of RX23E-A can correct the gain and the offset for the A/D conversion value.

For details, refer to "34.3.9 Offset Error/Gain Error Correction Function" in "RX23E-A Group User's Manual: Hardware".

For details about the calibration of temperature measurement with the RTD, refer to the application note, "RX23E-A Group Temperature Measurement Examples Using Resistance Temperature Detectors".

In this example, the gain of the digital filter is treated as being multiplied by the A/D conversion value. the expected value DATA for the A/D conversion value for the input voltage V can be calculated with the formula below, assuming that the set gain of the PGA is  $G_{PGA1}$ , the digital filter gain is  $G_{DF1}$ , the full scale of the A/D conversion value is  $2^{24}$ , and the A/D conversion reference voltage value is  $V_{REF}$ .

$$DATA = \frac{2^{24} \cdot G_{PGA1} \cdot G_{DF1}}{2 \cdot V_{REF}} \cdot V = \frac{2^{23} \cdot G_{PGA1} \cdot G_{DF1}}{V_{REF}} \cdot V$$

### 4.3.2 50Hz/60Hz Noise Reduction

By using the Sinc4 filter of the DSAD, 50Hz/60Hz noise reduction can be performed. In this example, by setting the output rate to 10SPS, 110dB attenuation is performed for  $\pm 1$ Hz at 50Hz/60Hz.

If the output rate is set to a value other than 10SPS, noise reduction is realized by filtering the A/D conversion value with the software.

For details, refer to the application notes, "RX23E-A Group Effective Use of AFE and DSAD".

### 4.3.3 AIN Chopping

If, for example, the offset drift due to temperature changes presents problems, the offset error can be reduced by averaging the results of A/D conversion performed by replacing the polarities of the signal input.

For details, refer to the application notes, "RX23E-A Group Effective Use of AFE and DSAD".

### 4.3.4 Linkage with the PC Tool Program

The sample program can communicate with the PC tool program of RSSKRX23E-A to display temperature measurement results with the PC tool program.

For details about the communication specifications, refer to "RSSKRX23E-A PC Tool Program Operation Manual".

The communication commands supported in this example are listed in Table 4-5.

Table 4-5 Supported Functions

Command	Overview	Remarks
Negotiation	Reads MCU endian information and MCU functions	
Read	Reads registers	
Run	Starts DSAD conversion operation	
Stop	Stops DSAD conversion operation	
TransmissionCh0	Transmits Ch0 data from the MCU	Transmits a temperature [°C] as a physical quantity

5. Sample Program

5.1 Overview of Operation

Figure 5-1 shows the process flow of this sample program.

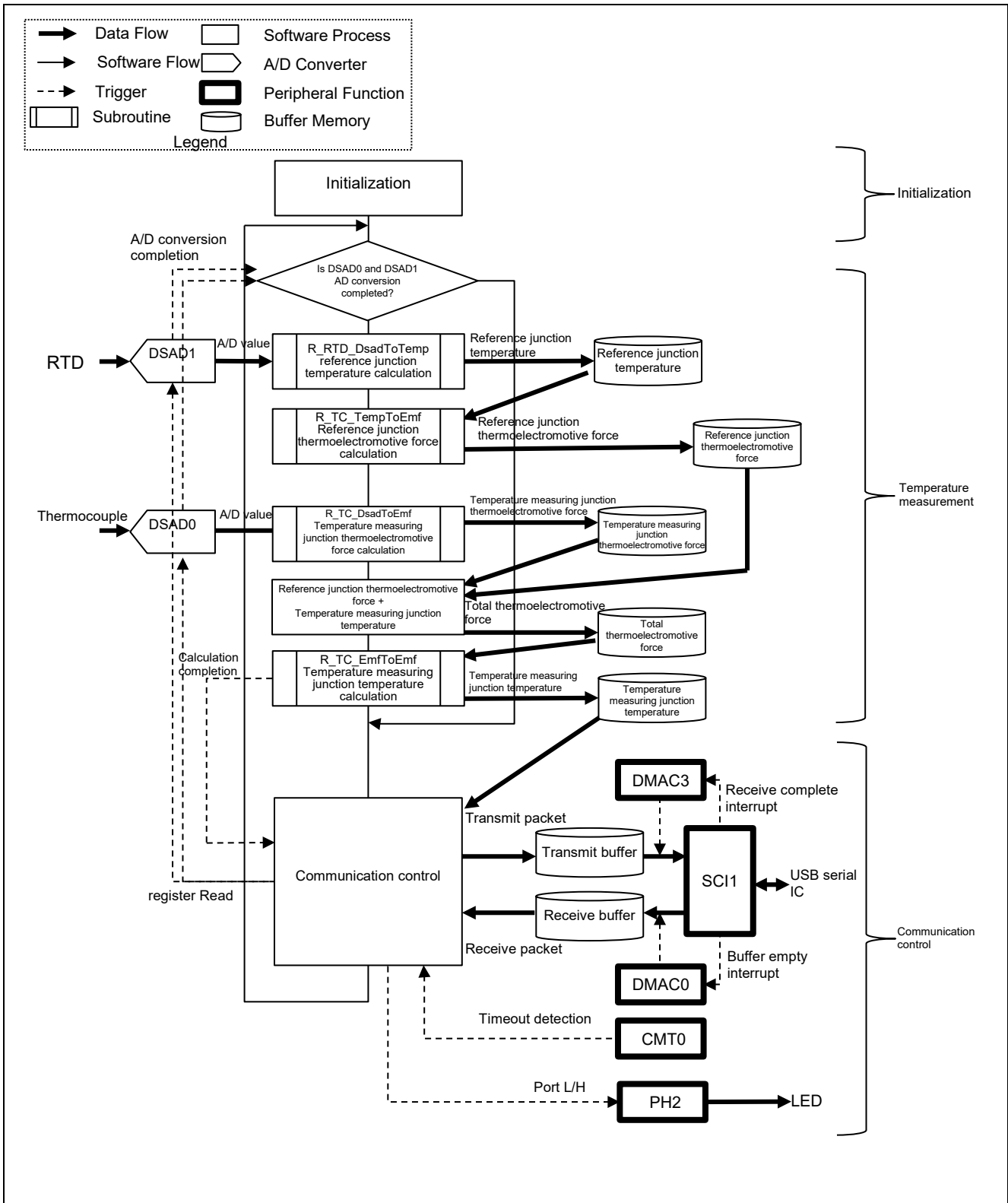

Figure 5-1 Temperature Measurement Process Flow

The following provides an overview of each process.

- Initialization

The following are performed.

- Initialization of DMAC
- If a connection is made to the PC tool program of RSSKRX23E-A, the initialization of the communication buffer and the start of SCI1 operation
- Start of the A/D conversion of DSAD0 and DSAD1

- Temperature measurement

With the end of the AD conversion of both DSAD0 and DSAD1 as a trigger, the temperature is calculated from each A/D conversion value. For details about the temperature calculation procedure, see 4.2.

- Communication control

A process of communication with the PC tool program of RSSKRX23E-A is performed to transmit measured temperature.

While measured temperature is being transmitted, LED1 is ON. For details, see 5.3.

## 5.2 Peripheral Functions and Pins Used

The peripheral functions used in this example are listed in Table 5-1, and the pins used are listed in Table 5-2. The conditions for setting each peripheral function are described together.

The settings for peripheral functions are generated by using the code generation function of Smart Configurator (referred to as SC in the remainder of this manual).

Table 5-1 Peripheral Functions Used

Peripheral function	Use
AFE, DSAD0, DSAD1	Driving of a thermocouple and an RTD and A/D conversion (AFE) of a thermocouple (DSAD0) and A/D conversion of an RTD (DSAD1)
SCI1	UART communication with the PC tool program
DMAC0	Data transfer with a receive complete interrupt of SCI1 as a trigger
DMAC3	Data transfer with a buffer empty interrupt of SCI1 as a trigger
CMT0	Detection of a communication timeout of SCI1
PH2	LED1 ON/OFF control

Table 5-2 Pins Used

Pin name	Input/Output	Use
PH2	Output	LED1 ON/OFF control
P26/TXD1	Output	UART1 transmit pin
P30/RXD1	Input	UART1 receive pin
P31/CTS1#	Input	CTS signal input pin
AIN11	Input	Thermocouple + side input pin
AIN10	Input	Thermocouple - side input pin
AIN9	Output	RTD excitation current output pin
AIN7	Input	RTD + side input pin
AIN6	Input	RTD - side input pin
AIN5/REF1P	Input	RTD measurement DSAD + side reference voltage
AIN4/REF1N	Input	RTD measurement DSAD - side reference voltage

## 5.2.1 AFE, DSAD0, and DSAD1

The conditions for setting AFE, DSAD0, and DSAD1 based on “Table 4-2 Thermocouple Measurement Conditions” and “Table 4-4 RTD Measurement Conditions” are listed in Table 5-3 and Table 5-4.

Table 5-3 DSAD Settings

Item		Setting	
Channel used		DSAD0	DSAD1
Analog input channel setting		<ul style="list-style-type: none"> <li>Channel 0: Valid</li> <li>Channels 1 to 5: Invalid</li> </ul>	
$\Delta\Sigma$ /D operating voltage select		3.6V-5.5V (high precision)	
$\Delta\Sigma$ /D converter operating mode setting		Normal mode	
Operating clock setting		PCLKB/8 (4MHz)	
Start trigger source		Software trigger	
Interrupt setting		Not used	
Inter-unit synchronous start setting		Enable synchronous start	
Abnormal voltage and disconnection detection Setting		Not used	
Channel 0	Analog input setting	<ul style="list-style-type: none"> <li>Positive input signal: AIN11</li> <li>Negative input signal: AIN10</li> <li>Reference voltage: REFOUT/AVSS0</li> </ul>	<ul style="list-style-type: none"> <li>Positive input signal: AIN7</li> <li>Negative input signal: AIN6</li> <li>Reference voltage: REF1P/REF1N</li> <li>Enable + side reference voltage buffer</li> <li>Enable - side reference voltage buffer</li> </ul>
	Amplifier setting	<ul style="list-style-type: none"> <li>Amplifier selection: PGA</li> <li>PGA gain setting: x128</li> </ul>	<ul style="list-style-type: none"> <li>Amplifier selection: PGA</li> <li>PGA gain setting: x32</li> </ul>
	$\Delta\Sigma$ /D conversion setting	<ul style="list-style-type: none"> <li>A/D conversion mode: Normal operation</li> <li>Data format: Two's complement format</li> <li>Number of A/D conversions: 1 in immediate value mode</li> <li>Oversampling ratio: 50000</li> <li>Offset correction: Not set (use of the device default)</li> <li>Gain correction: Not set (use of the device default)</li> <li>Use averaged data: Disabled</li> </ul>	
	Disconnection assist setting	Not permitted	

Table 5-4 AFE Settings

Item	Setting
Bias voltage output setting	<ul style="list-style-type: none"> <li>Bias voltage output enable</li> <li>AIN10: Output VBIAS</li> </ul>
Excitation current setting	<ul style="list-style-type: none"> <li>Excitation current output enable</li> <li>Operating mode: 2 channel output mode</li> <li>Excitation current: 500<math>\mu</math>A</li> <li>IEXC0 output pin: AIN9 pin</li> <li>IEXC0 disconnect detection assist : Disabled</li> <li>IEXC1 output pin: Output disabled</li> <li>IEXC1 disconnect detection assist : Disabled</li> </ul>
low voltage detector setting	Not set
Low-Side Switch Control setting	Not set

## 5.2.2 SCI1, DMAC0, DMAC3, and CMT0

For communication with the PC tool program, SCI1 is used in asynchronous mode. To obtain receive data, DMAC0 is used, and to set transmit data, DMAC3 is used. To detect a communication timeout, CMT0 is used.

The conditions for setting each peripheral function are listed below.

Table 5-5 SCI1 Settings

Item	Setting
Serial communication method	Asynchronous communication
Start bit detection setting	Low level at RXD1 pin
Data bit length	8 bits
Parity setting	Prohibited
Stop bit setting	1 bit
Data transfer direction setting	LSB first
Transfer speed setting	<ul style="list-style-type: none"> <li>• Transfer clock: Internal clock</li> <li>• Bit rate: 3 Mbps</li> <li>• Enable bit rate modulation function</li> <li>• SCK1 pin function: Not use SCK1</li> </ul>
Noise filter setting	Not use noise filter
Hardware flow control setting	CTS1#
Data processing setting	Transmit data processing: Process with DMAC3 Receive data processing: Process with DMAC0
Interrupt setting	Not permit receive error interrupt
Callback function setting	None
Input/output pins	<ul style="list-style-type: none"> <li>• Output: TXD1 (P30)</li> <li>• Input: RXD1 (P26)           : CTS1 (P31)</li> </ul>

Table 5-6 DMAC Settings

Item	Setting	
Channel used	DMAC0	DMAC3
DMA activation source	SCI1 (RXI1)	SCI1 (TXI1)
Activation source flag control	Clear activation source flag	Clear activation source flag
Transfer mode	Free running mode	Normal transfer
Transfer data size	8bit	8bit
Number of transfers/repeat size/block size	-	Set with software
Source address	<ul style="list-style-type: none"> <li>0008 A025h (SCI1.RDR)</li> <li>Address fixing</li> </ul>	<ul style="list-style-type: none"> <li>Set with software</li> <li>Address increment</li> <li>Set an extended repeat area at the destination address.</li> <li>Extended repeat area: Lower 12 bits of the address (4 KB)</li> </ul>
Destination address	<ul style="list-style-type: none"> <li>Set with software</li> <li>Address increment</li> <li>Set an extended repeat area at the destination address.</li> <li>Extended repeat area: Lower 9 bits of the address (512 bytes)</li> </ul>	<ul style="list-style-type: none"> <li>0008 A023h (SCI1.TDR)</li> <li>Address fixing</li> </ul>
Interrupt setting	Not permitted	Not permitted

Table 5-7 CMT0 Settings

Item	Setting
Clock setting	PCLKB/512
Compare match setting	Interval time: 1000ms Compare match interrupt (CMI0) enabled Level 0 (interrupt disabled)

### 5.2.3 PH2

By using PH2, LED1 is turned ON and OFF. While measurement results are being transmitted to the PC tool program, LED1 is ON. The condition for setting PH2 is listed in Table 5-8.

Table 5-8 PH2 Setting

Item	Setting
PORTH	PH2: Output CMOS output Output 1

5.3 Communication Control

Based on the communication specifications of RSSKRX23R-A, processes with the PC tool program are performed.

A flow of communication processes is shown in Figure 5-2.

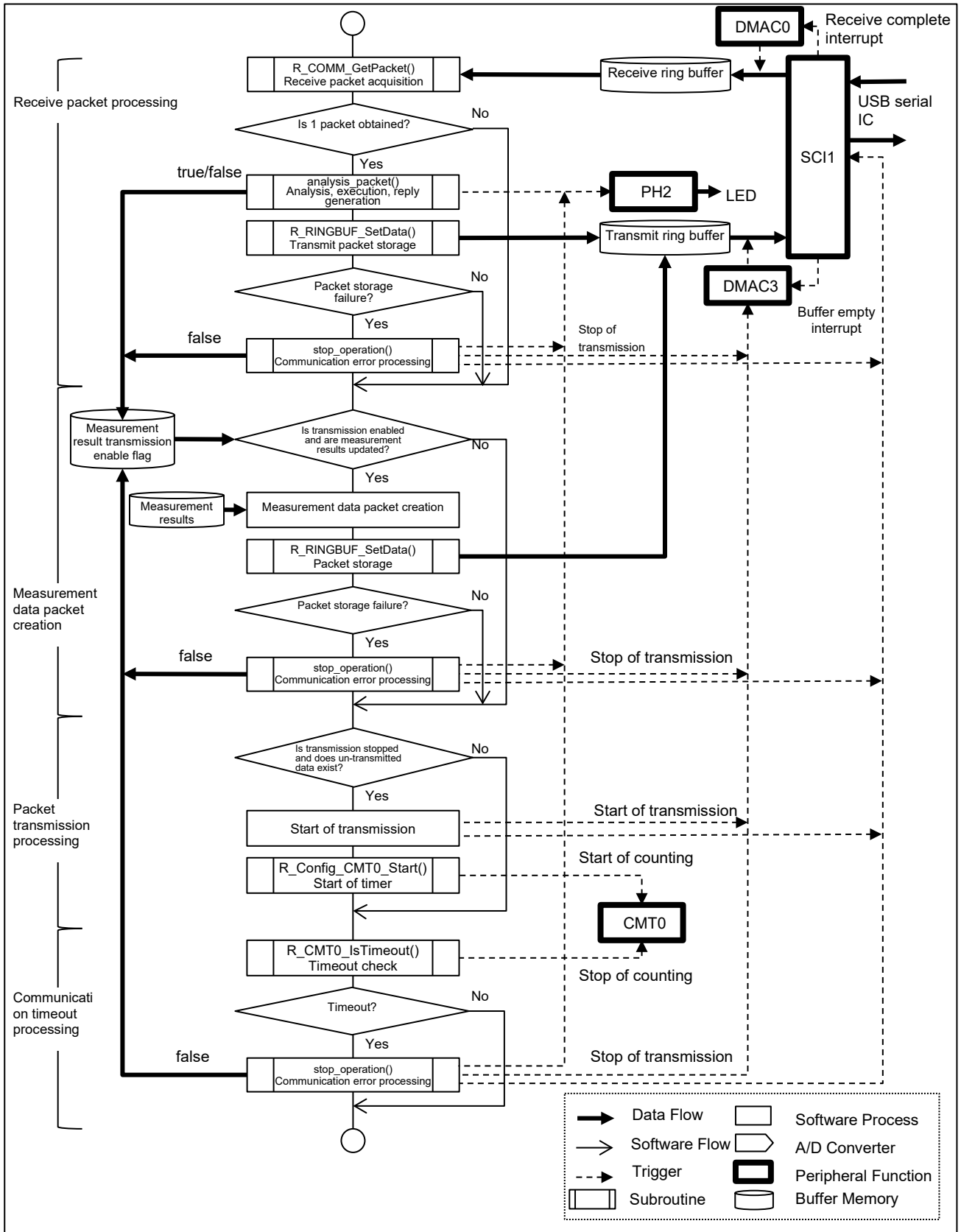

Figure 5-2 Communication Process Flow

The following provides an overview of each process.

- Receive packet processing

Obtains a received packet from the receive ring buffer, and performs processing corresponding to a command in the packet, then creates and stores a reply packet in the transmit ring buffer. Table 5-9 lists the commands supported by this program and the processes corresponding to the commands. For an unsupported command, a NACK is returned.

If the reply packet cannot be stored in the transmit ring buffer, communication error processing is performed.

Table 5-9 Packets and Actions

Command	Process
Negotiation	Return the software status with a reply packet
Read	Return the read value of the specified register with a reply packet
Run	Set the measurement result transmission enable flag and turn LED1 ON
Stop	Clear the measurement result transmission enable flag and turn LED1 OFF

- Measurement data packet creation

If the measurement result transmission enable flag is set and the measurement results are updated, a TransmissionCh0 reply packet is created from the measurement results and is stored in the transmit ring buffer.

If the reply packet cannot be stored in the transmit ring buffer, communication error processing is performed.

- Packet transmission processing

If data is not being transmitted and the transmit ring buffer contains un-transmitted data, transmission starts with DMAC3 and 1-second counting starts with CMT0 for timeout detection.

- Communication timeout processing

If transmission is completed, CMT0 for timeout detection is stopped.

If transmission is in progress, the timer is checked for a compare match, and if a compare match has occurred, this is judged as a timeout. If it is judged as a timeout, communication error processing is performed.

- Communication error processing

If the transmit packet cannot be stored in the transmit ring buffer or a communication timeout occurs, communication is stopped and the following processes are performed to make a reconnection possible.

- Stop SCI1 and DMAC3, which are used for transmission

- Clear the transmit buffer and the temperature data transmission enable flag

Turn LED1 OFF

Each ring buffer used for transmission and reception is for DMAC transmission, therefore, their address is arranged in the alignment adjusted for each buffer size. In this program, section name is declared "B\_DMAM\_REPEAT\_AREA\_1" and arrangement is set based on the largest buffer size.



## 5.4 Program Configuration

## 5.4.1 File Configuration

Table 5-10 File Configuration

Folder name, file name	Description	
src		
└ smc_gen	Smart Configurator generation	
├ general		
├ r_bsp		
├ Config_AFE		
├ Config_CMT0		
├ Config_DMACH0		
├ Config_DMACH3		
├ Config_DSAD0		
├ Config_DSAD1		
├ Config_PORT		
├ Config_SCI1		
└ r_config		
└ r_r_pincfg		
└ r_ring_buffer_control_api.c		Ring buffer control program
└ r_ring_buffer_control_api.h		Ring buffer control API definition
└ r_sensor_common_api.c	Table search, linear interpolation process program	
└ r_sensor_common_api.h	Table search, linear interpolation process API definition	
└ r_thermocouple_api.c	Thermocouple measurement calculation program, temperature vs. thermoelectromotive force table	
└ r_thermocouple_api.h	Thermocouple measurement calculation API definition	
└ r_rtd_api.c	Resistance temperature detector measurement calculation program, temperature vs. resistance value table	
└ r_rtd_api.h	Resistance temperature detector measurement calculation API definition	
└ r_communication_control_api.c	Communication control program	
└ r_communication_control_api.h	Communication control API definition	
└ main.c	Main processing	

## 5.4.2 Macro Definitions

Table 5-11 main.c Definition

Definition name	Type	Initial value	Description
D_PRV_PC_TOOL_USE	bool	1	Communication with the PC tool program is 0: Not used 1: Used

Table 5-12 r\_thermocouple\_api.h: Thermocouple Control Header File Definitions

Definition name	Type	Value	Description
D_TC_PGA_GAIN	float	128.0F	Gain of PGA for thermocouple measurement $G_{PGA0}$ [x]
D_TC_CODE_FS	uint32_t	8388608	$2^{23}$
D_TC_REFOUT	float	2.5F	REFOUT voltage $V_{REF0}$ [V]
D_TC_DF_GAIN	float	0.677626F	Digital filter gain $G_{DF0}$
D_TC_GAIN	float	$D\_TC\_REFOUT / (D\_TC\_CODE\_FS * D\_TC\_PGA\_GAIN * D\_TC\_DF\_GAIN) * 1000000$	Coefficient for conversion from A/D value to thermoelectromotive force [ $\mu$ V] $\frac{V_{REF0}}{2^{23} \cdot G_{PGA0} \cdot G_{DF0}} \cdot 10^6$
D_TC_OFFSET	float	0	Thermoelectromotive force offset [ $\mu$ V]
D_TC_TABLE_SIZE	uint16_t	327	Number of table elements (-75°C to 251°C)
D_TC_TABLE_TOP_TEMPARATURE	float	-75.0F	Top temperature in the table [°C]

Table 5-13 r\_rtd\_api.h: Resistance Temperature Detector Measurement Header File Definitions

Definition name	Type	Value	Description
D_RTD_PGA_GAIN	float	32.0F	Gain of PGA for RTD measurement $G_{PGA1}$ [x]
D_RTD_CODE_FS	uint32_t	8388608	$2^{23}$
D_RTD_RREF	float	5100F	RREF resistance value $R_{REF}$ [ $\Omega$ ]
D_RTD_DF_GAIN	float	0.677626F	Digital filter gain $G_{DF1}$
D_RTD_GAIN	float	$D\_RTD\_RREF / (D\_RTD\_CODE\_FS * D\_RTD\_PGA\_GAIN * D\_RTD\_DF\_GAIN)$	Coefficient for conversion from A/D value to RTD resistance value [ $\Omega$ ] $\frac{R_{REF}}{2^{23} \cdot G_{PGA1} \cdot G_{DF1}}$
D_RTD_OFFSET	float	0	RTD resistance value offset. [ $\Omega$ ]
D_RTD_TABLE_SIZE	uint16_t	127	Number of table elements
D_RTD_TABLE_TOP_TEMPARATURE	float	-40.0F	Top temperature in the table [°C]

## 5.4.3 Structure

Table 5-14 r\_ring\_buffer\_control\_api.h: Ring Buffer Control Header File Structure

Structure type name	st_ring_buf_t		
Member variable	Type	Name	Description
	uint8_t*	buf	Pointer to the ring buffer
	size_t	length	Ring buffer length
	uint32_t	r_index	Read index
	uint32_t	w_index	Write index

## 5.4.4 Functions

Table 5-15 main.c Functions

Function name/Overview	Return value		Argument			
	Type	Value	I/O	Type	Variable name	Description
main main function	void	-	-	void	-	-
stop_operation Stop DMAC/SCI, initializes the ring buffer and turns LED1 OFF	void	-	I	st_ring_buf_t *	ary	Pointer to the ring buffer
analysis_pakect According to the receive packet, executes the command and stores a reply packet. For the Run/Stop commands, updates the measurement result transmission enable flag.	size_t	Reply data length	I	uint8_t const	recv_pkt[]	Receive packet storage array
			O	uint8_t	send_pkt[]	Reply packet storage array
			O	bool *	p_tx_flag	Pointer to the measurement result transmission enable flag

Table 5-16 r\_communication\_control\_api Function

Function name/Overview	Return value		Argument			
	Type	Value	I/O	Type	Variable name	Description
R_COMM_GetPaket Reads a single packet from the receive ring buffer.	size_t	Packet length [Bytes]	I	st_ring_buf_t *	r_buf	Pointer to the receive ring buffer
			O	uint8_t	r_packet[]	Receive packet storage array

Table 5-17 r\_ring\_buffer\_control\_api Functions

Function name/Overview	Return value		Argument			
	Type	Value	I/O	Type	Variable name	Description
R_RINGBUF_GetData Reads a specified number of bytes from the ring buffer	size_t	Number of bytes to read	I	st_ring_buf_t *	ary	Pointer to the ring buffer
			O	uint8_t	data[]	Data storage array
			I	size_t	len	Number of bytes to read
			I	bool	index_update	Index update flag true: Update false: Not update
R_RINGBUF_SetData Writes a specified number of bytes to the ring buffer	size_t	Number of bytes to write	O	st_ring_buf_t *	ary	Pointer to the ring buffer
			I	uint8_t	data[]	Data storage array
			I	size_t	len	Number of bytes to write
R_RINGBUF_GetDataLength Reads a specified number of bytes stored in the ring buffer	size_t	Number of bytes stored	I	st_ring_buf_t *	ary	Pointer to the ring buffer
R_RINGBUF_SetDataIndex Updates the index of the ring buffer	uint32_t	Index value	O	st_ring_buf_t *	ary	Pointer to the ring buffer
			I	uint16_t	value	Index value
			I	uint8_t	select	Target index 0: Read, 1: Write

Table 5-18 r\_sensor\_common\_api Functions

Function name/Overview	Return value		Argument			
	Type	Value	I/O	Type	Variable name	Description
R_CALC_BinarySearch Does a binary search for the data to search for from the search table, and returns the index of a recent value that does not exceed the data to search for	uint16_t	Index value	I	const float *	p_data_table	Pointer to the search table (ascending order)
			I	uint16_t	table_size	Number of elements in the search table
			I	float	data	Data to search for
R_CALC_Lerp From two points (x0,y0) and (x1,y1), determine y for input x with linear interpolation	float	Linear interpolation results	I	float	x0	x0 value
			I	float	y0	y0 value
			I	float	x1	x1 value
			I	float	y1	y1 value
			I	float	x	x value

Table 5-19 r\_rtd\_api Function

Function name/Overview	Return value		Argument			
	Type	Value	I/O	Type	Variable name	Description
R_DsadToTemp Calculates the temperature from the A/D conversion value	float	Temperature [°C]	I	float	dsad	A/D conversion value

Table 5-20 r\_thermocouple\_api Functions

Function name/Overview	Return value		Argument			
	Type	Value	I/O	Type	Variable name	Description
R_TC_TempToEmf Calculates the thermoelectromotive force of the thermocouple from the temperature	float	Thermoelectromotive force [μV]	I	float	temp	Temperature [°C]
R_TC_DsadToEmf Calculates the thermoelectromotive force of the thermocouple from the A/D conversion value	float	Thermoelectromotive force [μV]	I	float	dsad	A/D conversion value
R_TC_EmfToTemp Calculates the temperature from the thermoelectromotive force of the thermocouple	float	Temperature [°C]	I	float	emf	Thermoelectromotive force [μV]

Table 5-21 Config\_CMT0 User Defined Functions

Function name/Overview	Return value		Argument			
	Type	Value	I/O	Type	Variable name	Description
R_CMT0_IsTimeout Returns information as to whether a timeout has occurred	bool	false: Counting true: Timeout	I	bool	flag	Stop of counting false: Continuation true: Stop
R_CMT0_CntClear Clears the compare match timer/counter of CMT0	void	-	-	void	-	-

Table 5-22 Config\_DMCA0 User Defined Functions

Function name/Overview	Return value		Argument			
	Type	Value	I/O	Type	Variable name	Description
R_DMCA0_SetDestAddr Sets the DMDAR of DMCA0	void	-	I	void *	p_addr	destination address
R_DMCA0_GetDestAddr Returns the DMDAR of DMCA0 (macro function)	void *	DMCA0.DMDAR	-	void	-	-

Table 5-23 Config\_DMCA3 User Defined Functions

Function name/Overview	Return value		Argument			
	Type	Value	I/O	Type	Variable name	Description
R_DMCA3_SetSrcAddr Sets the DMSAR of DMCA3	void	-	I	void *	p_addr	source address
R_DMCA3_SetTxCount Sets the DMCRA of DMCA3	void	-	-	uint32_t	cnt	transfer count

Table 5-24 Config\_DSAD0 User Defined Functions

Function name/Overview	Return value		Argument			
	Type	Value	I/O	Type	Variable name	Description
R_DSAD0_IsConversionEnd Returns information as to whether A/D conversion is in progress with the IR flag of DSAD0	bool	false: Conversion true: Conversion end	-	void	-	-
R_DSAD0_ClearIrFlag Clears the IR flag of DSAD0	void	-	-	void	-	-

Table 5-25 Config\_DSAD1 User Defined Functions

Function name/Overview	Return value		Argument			
	Type	Value	I/O	Type	Variable name	Description
R_DSAD1_IsConversionEnd Returns information as to whether A/D conversion is in progress with the IR flag of DSAD1	bool	false: Conversion true: Conversion end	-	void	-	-
R_DSAD1_ClearIrFlag Clears the IR flag of DSAD1	void	-	-	void	-	-

Table 5-26 Config\_PORT User Defined Functions

Function name/Overview	Return value		Argument			
	Type	Value	I/O	Type	Variable name	Description
R_LED1_On Turns LED1 ON (macro function)	void	-	-	void	-	-
R_LED1_Off Turns LED1 OFF (macro function)	void	-	-	void	-	-

Table 5-27 Config\_SCI1 User Defined Functions

Function name/Overview	Return value		Argument			
	Type	Value	I/O	Type	Variable name	Description
R_SCI1_IsTransferEnd returns the transfer status of SCI1	bool	false: Transferring true: Transfer end	-	void	-	-
R_SCI1_SendStart start transmission of SCI1	MD_STATUS	MD_OK	-	void	-	-
R_SCI1_SendStop stop transmission of SCI1	MD_STATUS	MD_OK	-	void	-	-
R_SCI1_ReceiveStart starts receiving of SCI1.	MD_STATUS	MD_OK	-	void	-	-

## 6. Importing a Project

After importing the sample project, make sure to confirm build and debugger setting.

### 6.1 Importing a Project into e<sup>2</sup> studio

Follow the steps below to import your project into e<sup>2</sup> studio. Pictures may be different depending on the version of e<sup>2</sup> studio to be used.

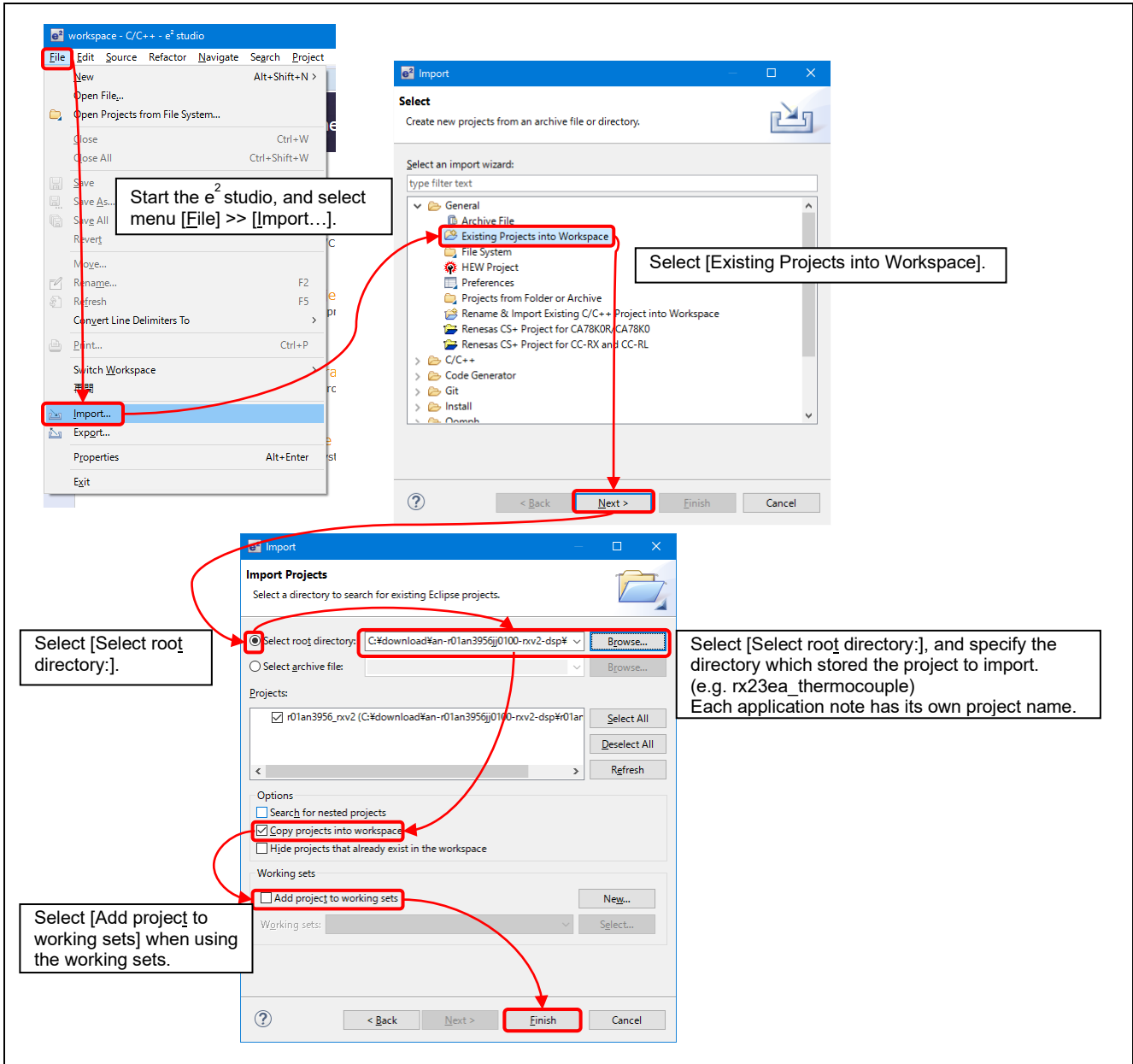

Figure 6-1 Importing a Project into e<sup>2</sup> studio

### 6.2 Importing a Project into CS+

Follow the steps below to import your project into CS+. Pictures may be different depending on the version of CS+ to be used.

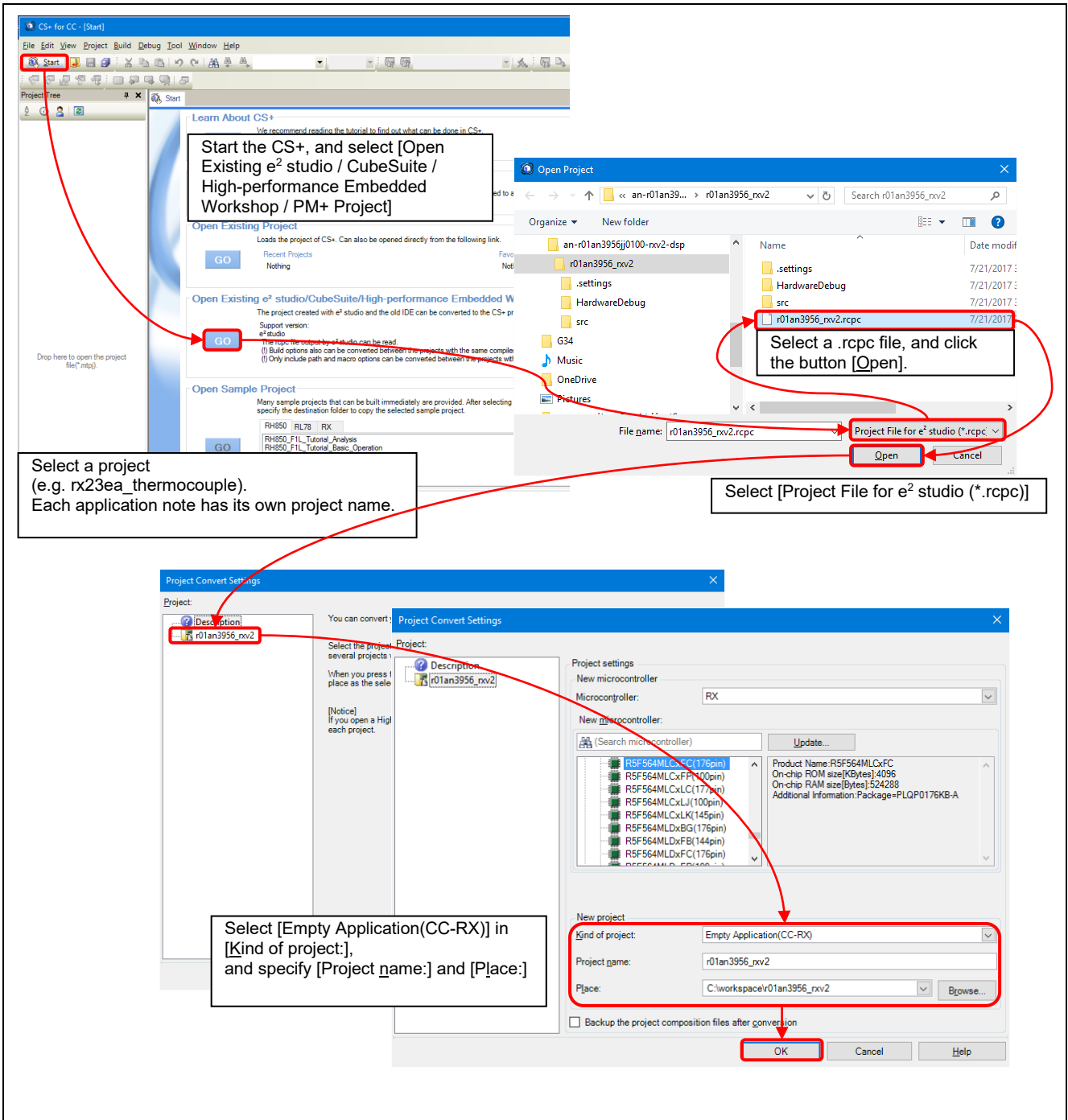

Figure 6-2 Importing a Project into CS+



## 7. Measurement Results with Sample Program

### 7.1 Memory Usage and Number of Execution Cycle

#### 7.1.1 Build Conditions

In “3 Environment for Operation Confirmation” build conditions for sample program is shown in Table 7-1. This setting is default setting when project is generated except for memory allocation to support the PC tool.

Table 7-1 Build Conditions

Item		Setting
Compiler	PC tool incompatible	-isa=rxv2 -utf8 -nomessage -output=obj -debug -outcode=utf8 -nologo
	PC tool compatible	add to the above -define=D_PRV_PC_TOOL_USE=1
Linker		-noprelink -output="rx23ea_thermocouple.abs" -form=absolute -nomessage -vect=_undefined_interrupt_source_isr -list=rx23ea_thermocouple.map -nooptimize -rom=D=R,D_1=R_1,D_2=R_2 -nologo
	Additional Section	-start=B_DMAC_REPEAT_AREA_1/02000

#### 7.1.2 Memory Usage

The amount of memory usage of sample program is shown in Table 7-2.

Table 7-2 Amount of memory Usage

Item	Size [byte]		Remarks
	PC tool incompatible	PC tool compatible	
ROM		10670	11117
	Code	7079	7526
	Data	3591	3591
RAM		7022 (2030)	12144 (7152) Note
	Data	1902	7024
	Stack	5120 (128)	5120 (128) Note

Note: RAM usage for stack is shown in “()”.

#### 7.1.3 The Number of Execution Cycle

The number of execution cycles and processing load for each block in “Figure 5-1 Temperature Measurement Process Flow” is shown in Table 7-3.

Table 7-3 Number of Execution Cycle

Block	Number of execution cycle (Execution time@ICLK=32MHz)	Process load [%]	Condition
Temperature measurement	446cycle (13.94usec)	0.014	Acquisition of A/D conversion value to temperature calculation
Communication control	348cycle (10.88usec)	0.011	Maximum number of processing cycles under normal operation

Note: Process load is calculated by the execution time in the DSAD output cycle (100msec).

## 7.2 Temperature Measurement

Temperature measurement results with thermocouple, XE-3505-001 shown in Table 4-1 are described in this section by using RSSKRX23E-A board and sample program.

### 7.2.1 Measurement Condition

System configuration of temperature measurement is illustrated in Figure 7-1. Equipment used in the measurement are shown in Table 7-4. Measurement results were acquired with PC tool program.

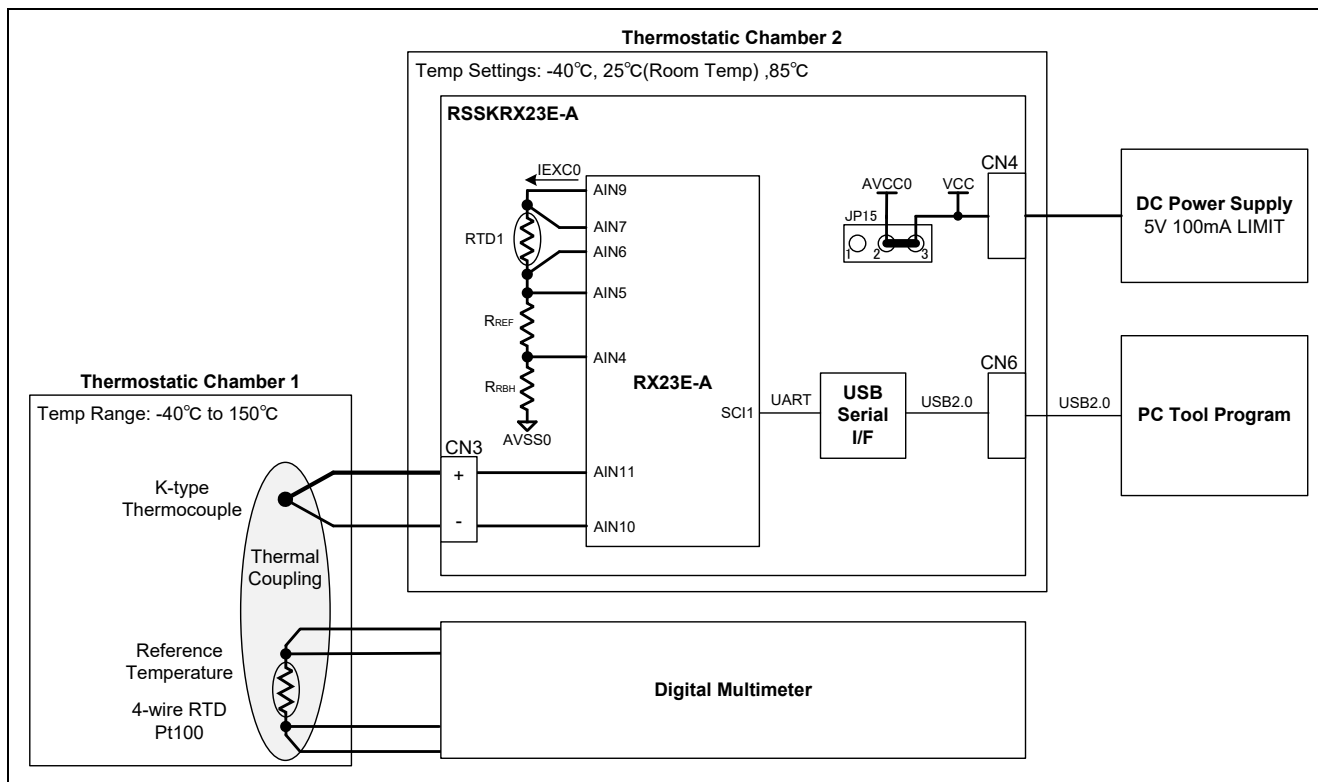

Figure 7-1 Configuration of Temperature Measurement by Thermocouple

Table 7-4 Equipment Used in Temperature Measurement by Thermocouple

Item	Model	Manufacturer
DC Power Supply	PCR1000MS	KIKUSUI ELECTRONICS CORPORATION
Thermocouple Calibrator	CA320	Yokogawa Test & Measurement Corporation
RTD Calibrator	CA330	Yokogawa Test & Measurement Corporation
Digital Multimeter	34461A	Keysight Technologies
4- Wire RTD Pt100	D00539/PS3/30/2000/PT100/CLA	Correge
Thermostatic Chamber 1	SU-241	ESPEC CORP.
Thermostatic Chamber 2	SU-240	ESPEC CORP.

### 7.2.2 Calibration

Calibration is carried out by correcting Gain/Offset of DSAD with calibrator, following “4.3.1 Calibration”. Condition for calibration is shown in Table 7-5.

Table 7-5 Calibration Condition

Subject	Calibration points	Condition
Thermocouple measurement (DSAD0)	-40°C, 150°C equivalent	Board temperature : Room temperature (about 25°C)
Reference junction compensation (DSAD1)	0°C, 150°C equivalent	

7.2.3 Measurement results

Figure 7-2 shows measurement error =  $T - T_{REF}$  for each ambient temperature, as reference temperature  $T_{REF}$  which measured as 4-wire RTD for reference temperature, and as the measurement result  $T$ . The horizontal axis shows temperature in the thermostatic chamber and the vertical axis shows measurement error. The error of sensor (error between K thermocouple and 4-wire RTD is added) is shown by the gray solid line as the guide of accuracy.

You can see RX23E-A has sufficient measurement accuracy, judging from the fact that the measurement temperature is within the error range of the sensor for each board ambient temperature.

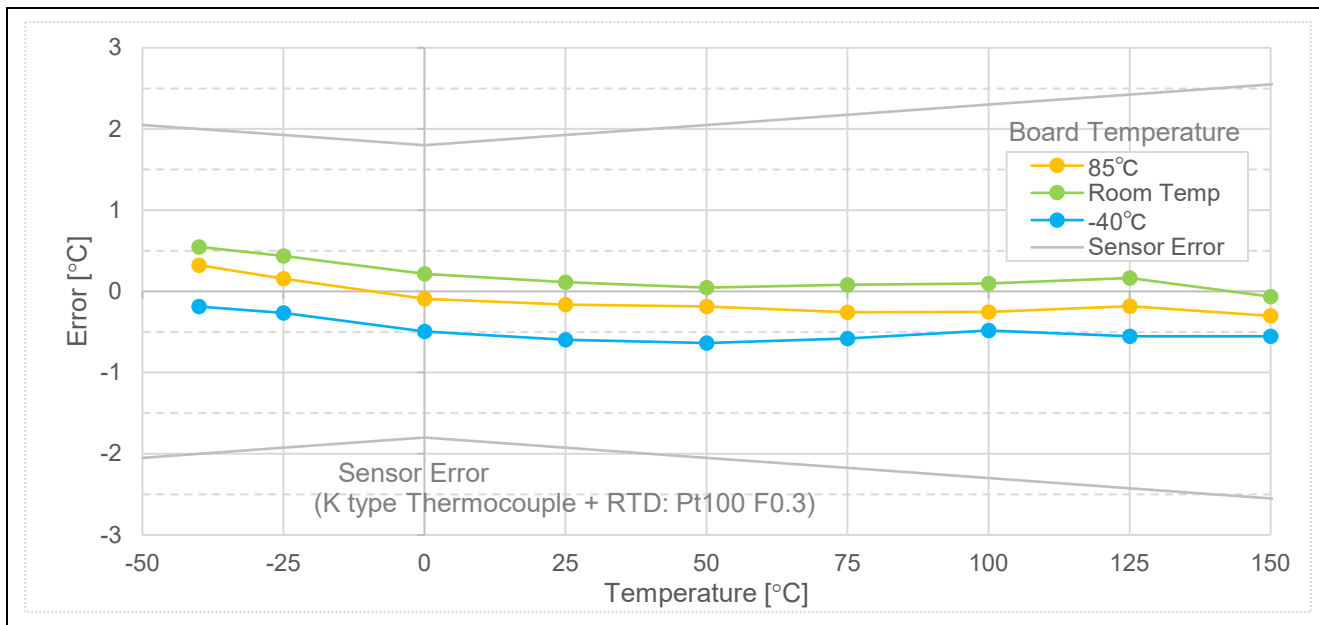

Figure 7-2 Temperature Measurement Result by Thermocouple

Histogram of deviation from average value of 1,000 samples of temperature measurement value in room temperature is shown in Figure 7-3. Temperature deviation was 1.5m°C at rms value, and 8.6m°C at P-P value. Voltage temperature sensitivity of K thermocouple is 39uV/°C, therefore input conversion voltage is 57.4nVrms and 335.4nV at P-P value. Effective resolution and noise free resolution calculated with above-mentioned values are shown below. Although noise of thermocouple was added to input conversion noise of typ. 33nVrms with RX23E-A setting 10SPS and 128 times PGA gain, RX23E-A is shown to be capable of highly accurate temperature measurement.

Effective resolution :	19.4bit (57.4nVrms: 1.5m°C equivalent)
Noise free resolution :	16.8bit (335.4nV: 8.6m°C equivalent)

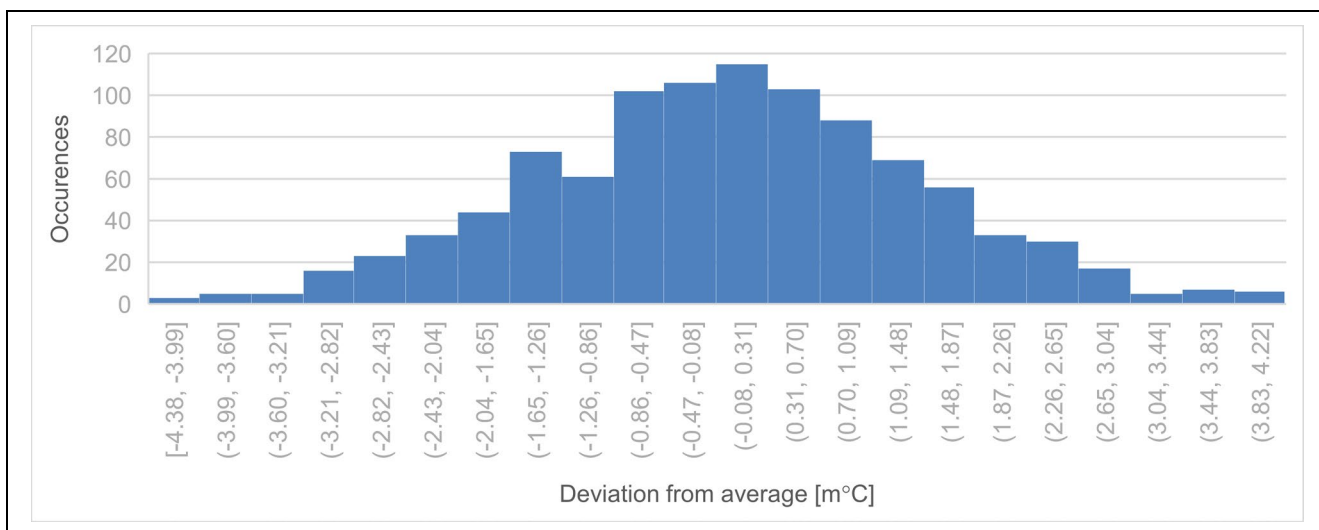

Figure 7-3 Histogram of Temperature Measurement Result in Room Temperature

## Revision History

Rev.	Date	Description	
		Page	Summary
1.00	Nov. 28.19	-	First release
1.10	July 20.20	p.3 p.7 p.12 p.25	Table 3-1: Update of IDE and Tool Chain 4.2Temperature Calculation Procedure: Error correction of the Temperature $T_{RTD}$ formula Table 5-3,Table 5-4: Update of the Smart Configurator setting Table 7-1,Table 7-2,Table 7-3: Modification due to the update of IDE and Tool Chain Others: Correction of the written error and addition of the description

# General Precautions in the Handling of Microprocessing Unit and Microcontroller Unit Products

The following usage notes are applicable to all Microprocessing unit and Microcontroller unit products from Renesas. For detailed usage notes on the products covered by this document, refer to the relevant sections of the document as well as any technical updates that have been issued for the products.

## 1. Precaution against Electrostatic Discharge (ESD)

A strong electrical field, when exposed to a CMOS device, can cause destruction of the gate oxide and ultimately degrade the device operation. Steps must be taken to stop the generation of static electricity as much as possible, and quickly dissipate it when it occurs. Environmental control must be adequate. When it is dry, a humidifier should be used. This is recommended to avoid using insulators that can easily build up static electricity. Semiconductor devices must be stored and transported in an anti-static container, static shielding bag or conductive material. All test and measurement tools including work benches and floors must be grounded. The operator must also be grounded using a wrist strap. Semiconductor devices must not be touched with bare hands. Similar precautions must be taken for printed circuit boards with mounted semiconductor devices.

## 2. Processing at power-on

The state of the product is undefined at the time when power is supplied. The states of internal circuits in the LSI are indeterminate and the states of register settings and pins are undefined at the time when power is supplied. In a finished product where the reset signal is applied to the external reset pin, the states of pins are not guaranteed from the time when power is supplied until the reset process is completed. In a similar way, the states of pins in a product that is reset by an on-chip power-on reset function are not guaranteed from the time when power is supplied until the power reaches the level at which resetting is specified.

## 3. Input of signal during power-off state

Do not input signals or an I/O pull-up power supply while the device is powered off. The current injection that results from input of such a signal or I/O pull-up power supply may cause malfunction and the abnormal current that passes in the device at this time may cause degradation of internal elements. Follow the guideline for input signal during power-off state as described in your product documentation.

## 4. Handling of unused pins

Handle unused pins in accordance with the directions given under handling of unused pins in the manual. The input pins of CMOS products are generally in the high-impedance state. In operation with an unused pin in the open-circuit state, extra electromagnetic noise is induced in the vicinity of the LSI, an associated shoot-through current flows internally, and malfunctions occur due to the false recognition of the pin state as an input signal become possible.

## 5. Clock signals

After applying a reset, only release the reset line after the operating clock signal becomes stable. When switching the clock signal during program execution, wait until the target clock signal is stabilized. When the clock signal is generated with an external resonator or from an external oscillator during a reset, ensure that the reset line is only released after full stabilization of the clock signal. Additionally, when switching to a clock signal produced with an external resonator or by an external oscillator while program execution is in progress, wait until the target clock signal is stable.

## 6. Voltage application waveform at input pin

Waveform distortion due to input noise or a reflected wave may cause malfunction. If the input of the CMOS device stays in the area between  $V_{IL}$  (Max.) and  $V_{IH}$  (Min.) due to noise, for example, the device may malfunction. Take care to prevent chattering noise from entering the device when the input level is fixed, and also in the transition period when the input level passes through the area between  $V_{IL}$  (Max.) and  $V_{IH}$  (Min.).

## 7. Prohibition of access to reserved addresses

Access to reserved addresses is prohibited. The reserved addresses are provided for possible future expansion of functions. Do not access these addresses as the correct operation of the LSI is not guaranteed.

## 8. Differences between products

Before changing from one product to another, for example to a product with a different part number, confirm that the change will not lead to problems. The characteristics of a microprocessing unit or microcontroller unit products in the same group but having a different part number might differ in terms of internal memory capacity, layout pattern, and other factors, which can affect the ranges of electrical characteristics, such as characteristic values, operating margins, immunity to noise, and amount of radiated noise. When changing to a product with a different part number, implement a system-evaluation test for the given product.

## Notice

1. Descriptions of circuits, software and other related information in this document are provided only to illustrate the operation of semiconductor products and application examples. You are fully responsible for the incorporation or any other use of the circuits, software, and information in the design of your product or system. Renesas Electronics disclaims any and all liability for any losses and damages incurred by you or third parties arising from the use of these circuits, software, or information.
2. Renesas Electronics hereby expressly disclaims any warranties against and liability for infringement or any other claims involving patents, copyrights, or other intellectual property rights of third parties, by or arising from the use of Renesas Electronics products or technical information described in this document, including but not limited to, the product data, drawings, charts, programs, algorithms, and application examples.
3. No license, express, implied or otherwise, is granted hereby under any patents, copyrights or other intellectual property rights of Renesas Electronics or others.
4. You shall not alter, modify, copy, or reverse engineer any Renesas Electronics product, whether in whole or in part. Renesas Electronics disclaims any and all liability for any losses or damages incurred by you or third parties arising from such alteration, modification, copying or reverse engineering.
5. Renesas Electronics products are classified according to the following two quality grades: "Standard" and "High Quality". The intended applications for each Renesas Electronics product depends on the product's quality grade, as indicated below.  
"Standard": Computers; office equipment; communications equipment; test and measurement equipment; audio and visual equipment; home electronic appliances; machine tools; personal electronic equipment; industrial robots; etc.  
"High Quality": Transportation equipment (automobiles, trains, ships, etc.); traffic control (traffic lights); large-scale communication equipment; key financial terminal systems; safety control equipment; etc.  
Unless expressly designated as a high reliability product or a product for harsh environments in a Renesas Electronics data sheet or other Renesas Electronics document, Renesas Electronics products are not intended or authorized for use in products or systems that may pose a direct threat to human life or bodily injury (artificial life support devices or systems; surgical implantations; etc.), or may cause serious property damage (space system; undersea repeaters; nuclear power control systems; aircraft control systems; key plant systems; military equipment; etc.). Renesas Electronics disclaims any and all liability for any damages or losses incurred by you or any third parties arising from the use of any Renesas Electronics product that is inconsistent with any Renesas Electronics data sheet, user's manual or other Renesas Electronics document.
6. When using Renesas Electronics products, refer to the latest product information (data sheets, user's manuals, application notes, "General Notes for Handling and Using Semiconductor Devices" in the reliability handbook, etc.), and ensure that usage conditions are within the ranges specified by Renesas Electronics with respect to maximum ratings, operating power supply voltage range, heat dissipation characteristics, installation, etc. Renesas Electronics disclaims any and all liability for any malfunctions, failure or accident arising out of the use of Renesas Electronics products outside of such specified ranges.
7. Although Renesas Electronics endeavors to improve the quality and reliability of Renesas Electronics products, semiconductor products have specific characteristics, such as the occurrence of failure at a certain rate and malfunctions under certain use conditions. Unless designated as a high reliability product or a product for harsh environments in a Renesas Electronics data sheet or other Renesas Electronics document, Renesas Electronics products are not subject to radiation resistance design. You are responsible for implementing safety measures to guard against the possibility of bodily injury, injury or damage caused by fire, and/or danger to the public in the event of a failure or malfunction of Renesas Electronics products, such as safety design for hardware and software, including but not limited to redundancy, fire control and malfunction prevention, appropriate treatment for aging degradation or any other appropriate measures. Because the evaluation of microcomputer software alone is very difficult and impractical, you are responsible for evaluating the safety of the final products or systems manufactured by you.
8. Please contact a Renesas Electronics sales office for details as to environmental matters such as the environmental compatibility of each Renesas Electronics product. You are responsible for carefully and sufficiently investigating applicable laws and regulations that regulate the inclusion or use of controlled substances, including without limitation, the EU RoHS Directive, and using Renesas Electronics products in compliance with all these applicable laws and regulations. Renesas Electronics disclaims any and all liability for damages or losses occurring as a result of your noncompliance with applicable laws and regulations.
9. Renesas Electronics products and technologies shall not be used for or incorporated into any products or systems whose manufacture, use, or sale is prohibited under any applicable domestic or foreign laws or regulations. You shall comply with any applicable export control laws and regulations promulgated and administered by the governments of any countries asserting jurisdiction over the parties or transactions.
10. It is the responsibility of the buyer or distributor of Renesas Electronics products, or any other party who distributes, disposes of, or otherwise sells or transfers the product to a third party, to notify such third party in advance of the contents and conditions set forth in this document.
11. This document shall not be reprinted, reproduced or duplicated in any form, in whole or in part, without prior written consent of Renesas Electronics.
12. Please contact a Renesas Electronics sales office if you have any questions regarding the information contained in this document or Renesas Electronics products.

(Note1) "Renesas Electronics" as used in this document means Renesas Electronics Corporation and also includes its directly or indirectly controlled subsidiaries.

(Note2) "Renesas Electronics product(s)" means any product developed or manufactured by or for Renesas Electronics.

(Rev.4.0-1 November 2017)

## Corporate Headquarters

TOYOSU FORESIA, 3-2-24 Toyosu,  
Koto-ku, Tokyo 135-0061, Japan  
[www.renesas.com](http://www.renesas.com)

## Trademarks

Renesas and the Renesas logo are trademarks of Renesas Electronics Corporation. All trademarks and registered trademarks are the property of their respective owners.

## Contact information

For further information on a product, technology, the most up-to-date version of a document, or your nearest sales office, please visit:  
[www.renesas.com/contact/](http://www.renesas.com/contact/).