

RL78/L23

Capacitive Touch Evaluation System Sample Code

Introduction

This document describes the contents of the sample code for the RL78/L23 Capacitive Touch Evaluation System.

Target Device

RL78/L23 (R7F100LPL3CFB)

Contents

1. Overview	2
1.1 Function	2
2. Operation Confirmation Conditions	3
3. Software Specification	4
3.1 Software Structure Diagram	4
3.2 List of Peripheral Functions Used and Pins Used	5
3.3 File Structure	8
3.4 Setting of Option Byte	9
3.5 Constants	10
3.6 Enumerations	11
3.7 Global Variables	11
3.8 Functions	12
3.9 Processing Flowchart	13
4. Capacitive Touch Setting	14
4.1 Touch Interface Configuration	14
4.2 Configuration (methods) Settings	14
4.3 Tuning Results	15
4.4 How to adjust the sensitivity	16
5. Support	17
Revision History	18

1. Overview

This sample code is software that operates with capacitive touch in the RL78/L23 Capacitive Touch Evaluation system. The following is added to the project created by e² studio.

- Components generated by the Smart Configurator
- Capacitive touch configuration files and applications generated by QE for Capacitive Touch (QE)
- LED control application

1.1 Function

The functions are shown below.

1. When the power is turned on and started, the LED test is performed. First, turn on LEDs 1 and 2 on the CPU board. After that, the LEDs on the electrode board are turned on and off in the order of buttons, sliders, and wheels. (See Figure 1-1.)
2. The LEDs are controlled in conjunction with the operation of the three buttons, wheel, and slider on the touch electrode board. (See Figure 1-2). LED control is performed in conjunction with the push button on CPU board. Pressing SW1, LED1 lights up. Pressing SW2, LED2 lights up. (See Figure 1-2)

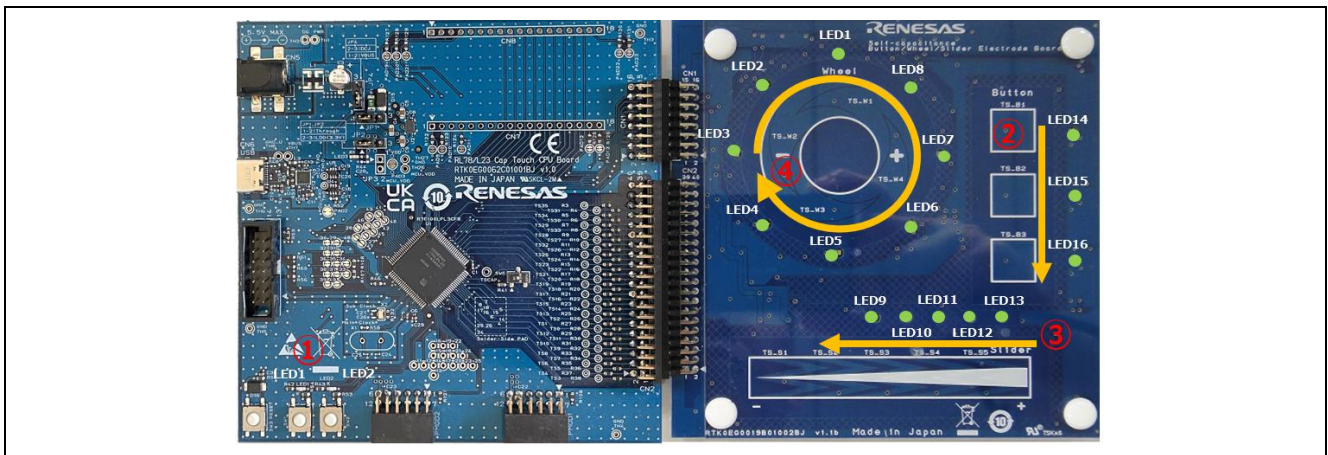

Figure 1-1 LED Testing During Software Startup

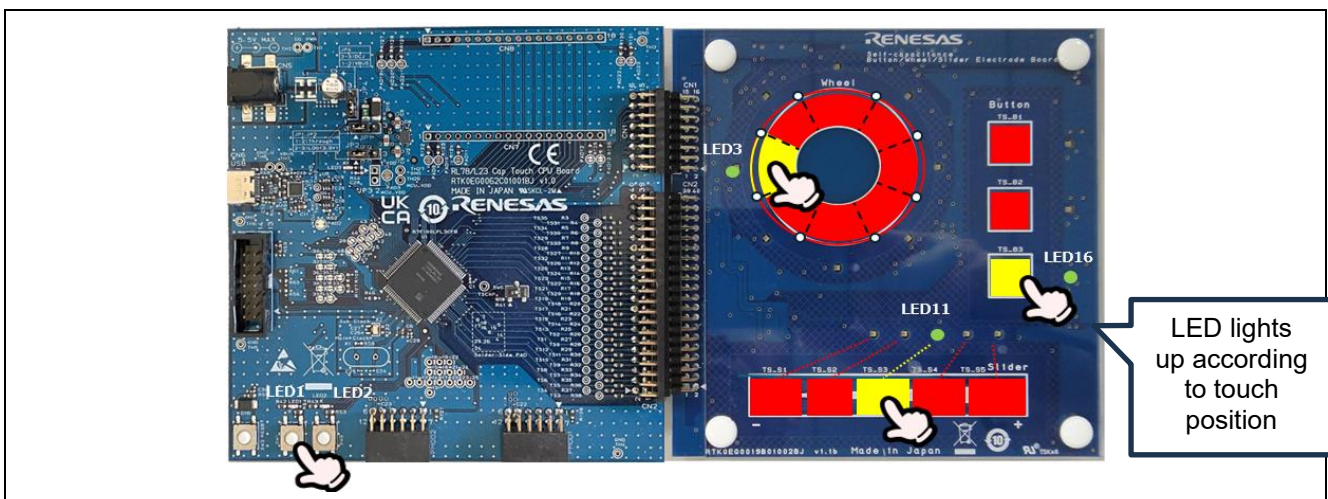

Figure 1-2 LED Control in Conjunction with Capacitive Touch Buttons, Sliders, and Wheel Movements

2. Operation Confirmation Conditions

The operation of this sample code has been confirmed the following environment.

Table 2-1 Operation Confirmation Conditions

Item	Contents
MCU	RL78/L23 (R7F100LPL3CFB)
Operating frequency	32MHz
Operating voltage	5.0V (USB power) LVD0 detection voltage : Reset mode At rising edge TYP. 2.67V(TYP) (2.59V to 2.75V) At falling edge TYP. 2.62V(TYP) (2.54V to 2.70V)
Evaluation board	Capacitive Touch Evaluation System for RL78/L23 (Product No : RTK0EG0063S01001BJ) <ul style="list-style-type: none"> • RL78/L23 CPU Board (Product No:RTK0EG0062C01001BJ) • Capacitive Touch Evaluation Application Board — Self-Capacitance Buttons / Wheels / Slider Board (Product No:RTK0EG0019B01002BJ)
Integrated development environment	e ² studio Version 2025-07
C Compiler	CC-RL V1.15.00 Compile options of optimization: -Odefault
Development Assistance Tool for Capacitive Touch Sensors	QE for Capacitive Touch V4.2.0
Emulator	Renesas E2 Emulator Lite

Figure 2-1 shows device connection diagram.

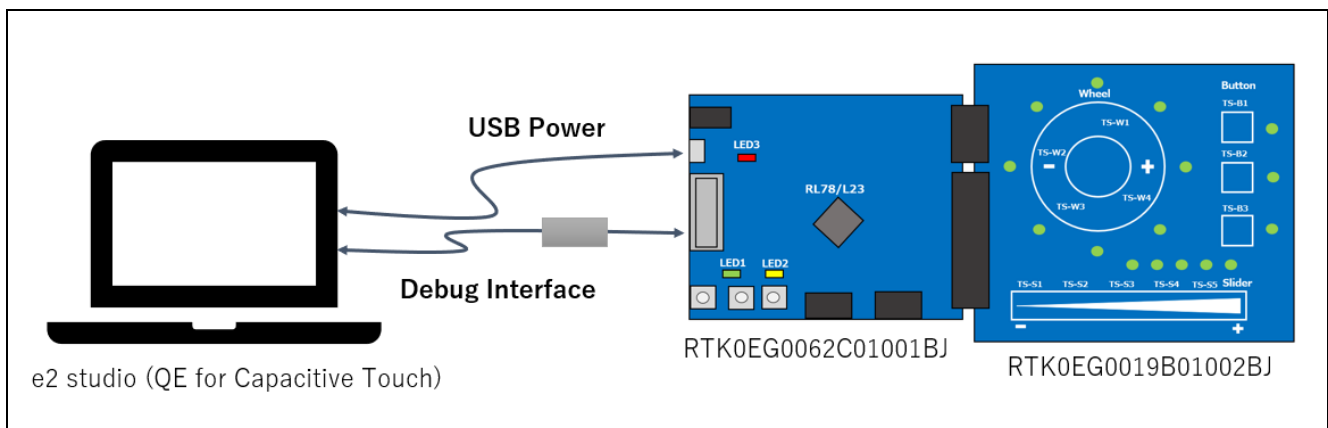

Figure 2-1 Device Connection Diagram

3. Software Specification

3.1 Software Structure Diagram

Figure 3-1 shows the software structure diagram of this sample code. This software uses components generated by the Smart Configurator.

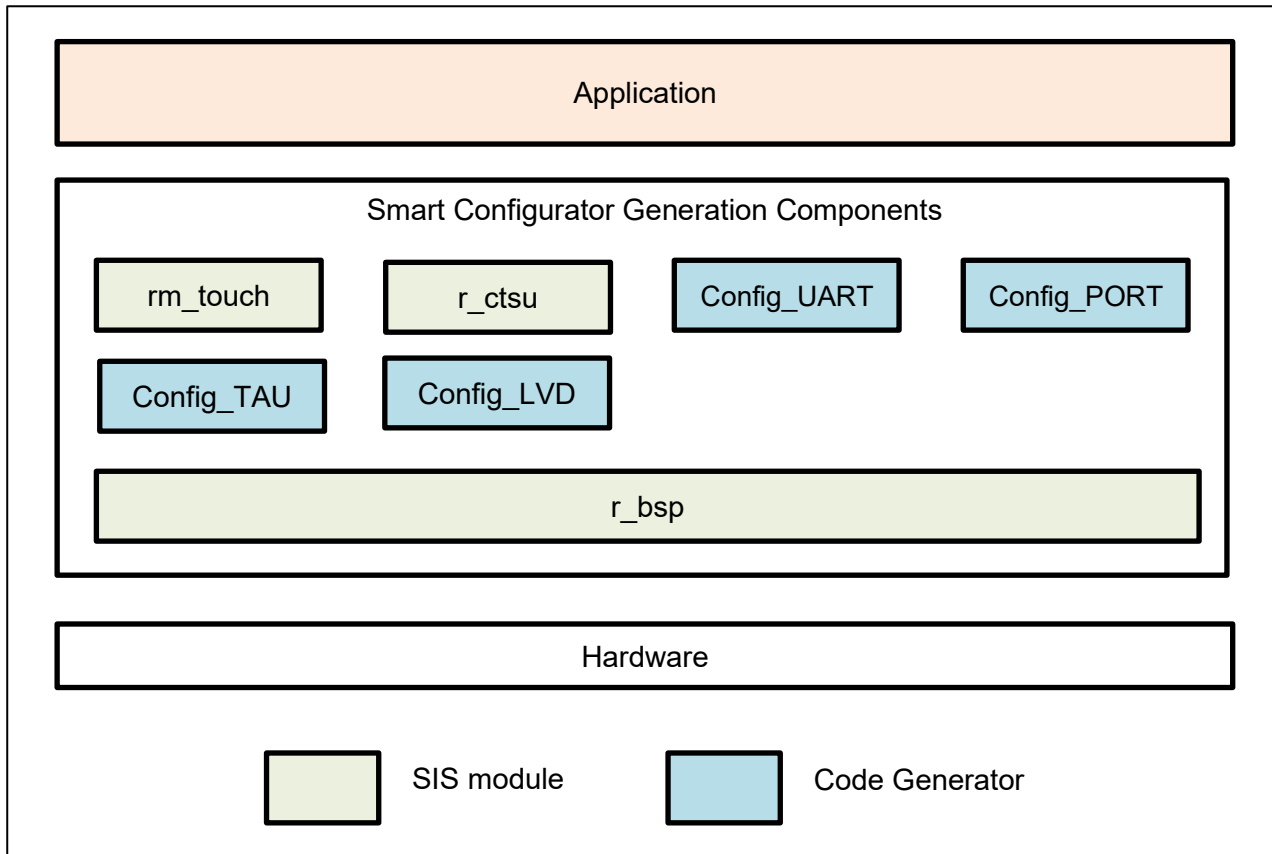

Figure 3-1 Software structure diagram

Table 3-1 shows a list of components and versions. Refer to the smart configurator for component settings.

Table 3-1 Components and versions list

Component	Version	Configuration
✔ Board Support Packages. - v1.91 (r_bsp)	1.91	r_bsp(used)
✔ Capacitive Sensing Unit driver. (r_ctsu)	2.20	r_ctsu(used)
✔ Interval Timer	1.8.0	Config_TAU0_0(TAU0_0: used)
✔ Ports	1.8.0	Config_PORT(PORT: used)
✔ Touch middleware. (rm_touch)	2.20	rm_touch(used)
✔ UART Communication	1.10.0	Config_UART2(UART2: used)
✔ Voltage Detector	1.6.1	Config_LVD0(LVD0: used)

3.2 List of Peripheral Functions Used and Pins Used

The peripheral function settings using Smart Configurator are shown below.

Table 3-2 shows a list of peripheral functions used.

Table 3-2 List of Peripheral Functions Used

Peripheral Function	Usage
TOUCH	Touch control
CTSU	CTSU measurement
UART2	QE serial monitoring and serial tuning
TAU0	LED control trigger
PORT	LED control, Unused pin control
LVD0	Voltage Detector

➤ Touch middleware(rm_touch).

Use rm_touch for touch control. Table 3-3 shows the rm_touch settings. This setting enables QE serial monitoring and serial tuning.

Table 3-3 Touch middleware(rm_touch) Setting

Item	Setting
Support QE monitor using UART	Enable
Support QE tuning using UART	Enable
UART channel	UART2
Type of chattering suppression	TypeA

➤ CTSU (r_ctsu).

Use CTSU to run touch measurement. Table 3-7 shows the TS terminal settings. The CTSU setting is the default setting without the TS terminal settings.

➤ Voltage Detector

The reset generation voltage settings are shown in Table 3-4.

Table 3-4 Voltage Detector Setting

Item	Setting
Operation mode	Reset mode
Detection level Reset generation voltage(VLVD0)	2.62V

➤ UART communication

Use UART2 for serial monitoring of QE for Capacitive Touch.

Table 3-5 shows the UART2 settings.

Table 3-5 UART2 Setting

Item	Setting
Operation clock	CK10
Clock Source	fCLK/2 ⁴
Transfer mode setting	Single transfer mode
Data length setting	8 bits
Transfer direction setting	LSB
Parity setting	None
Stop bit length setting	1 bit
Transfer data level setting	None-reverse
Transfer rate setting	115200 bps
Interrupt- setting: Transmit	Transmit end interrupt priority(INTST2): Level 3 (low)
Interrupt- setting: Receive	Reception end interrupt priority(INTSR2): Level 3 (low) Reception error interrupt priority(INTSRE2): Level 3 (low)
Callback function setting: Transmit	Transmission end : Enable
Callback function setting : Receive	Reception end : Enable Reception error : Enable

➤ Interval Timer

Use TAU0_0 for LED control. Table 3-6 shows the TAU0_0 settings.

Table 3-6 TAU0_0 Setting

Item	Setting
Operation clock	CK00
Clock source	fCLK/2 ⁸
Interval value (16 bits)	5 ms
Interrupt setting	End of timer channel0 count, generate an interrupt (INTTM00) : Enable Priority: Level 3 (low)

➤ Ports

Table 3-7 and Table 3-8 shows a list of used pins, and Table 3-9 shows a list of handling of unused pins in this sample software.

Table 3-7 List of used pins(1)

Pin No.	Pin Name	I/O	Usage
34	TS03	I/O	CTS measurement
35	TS04	I/O	
36	TS05	I/O	
37	TS06	I/O	
39	TS07	I/O	
40	TS08	I/O	
41	TS09	I/O	
42	TS10	I/O	
43	TS11	I/O	
44	TS12	I/O	
56	TS21	I/O	
69	TS32	I/O	
70	TS33	I/O	
71	TS34	I/O	
72	TS35	I/O	
51	TSCAP	-	

Table 3-8 List of used pins(2)

Pin No.	Pin Name	I/O	Usage
74	P147/RxD2	I	QE serial communication
75	P146/TxD2	O	
22	P60/SW1	I	Switch Input
23	P61/SW2	I	
24	P64/LED1	O	LED Control
25	P65/LED2	O	
99	P21/LED_ROW0	O	
100	P20/LED_ROW1	O	
68	P81/LED_ROW2	O	
73	P80/LED_ROW3	O	
1	P140/LED_COL0	O	
49	P84/LED_COL1	O	
50	P83/LED_COL2	O	
67	P82/LED_COL3	O	

Table 3-9 List of Handling of Unused Pins

Pin No	Pin Name	I/O	Handling
19	REGC	-	-
21	VDD		
20	VSS		
38	EVSS		
8	P42	I	Set to input port
9	P41	I	
16	P137	I	
26	P62	I	
27	P63	I	
Pins than the above		-	Low output

3.3 File Structure

This is the file structure of this sample code. The project configuration file and smart configurator generation file of the development environment are omitted.

rl78l23_rssk_sample

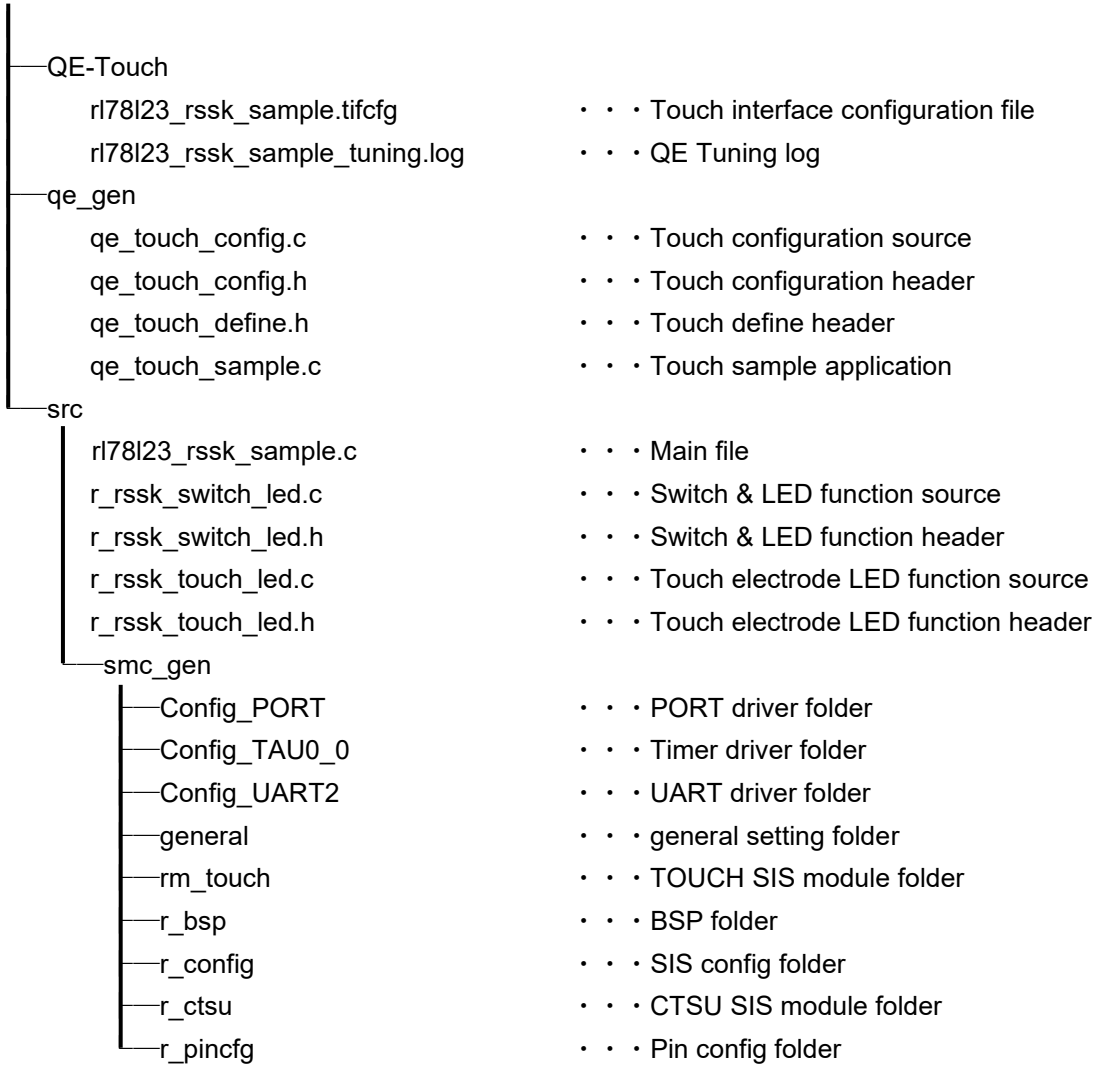

3.4 Setting of Option Byte

Table 3-10 shows the option byte settings.

Table 3-10 Option Byte Settings

Address	Setting Value	Contents
000C0H / 040C0H	1110 1111b(0xEF)	Disables the watchdog timer. (Counting stopped after reset)
000C1H / 040C1H	1111 1100b(0xFC)	LVD0 detection voltage : Reset mode At rising edge TYP. 2.67V(TYP) (2.59V to 2.75V) At falling edge TYP. 2.62V(TYP) (2.54V to 2.70V)
000C2H / 040C2H	1110 1000b(0xE8)	HS (high-speed main) mode High-speed on-chip oscillator clock: 32 MHz
000C3H / 040C3H	1000 0100b(0x84)	Enables on-chip debugging

Figure 3-2 shows the screen to check with the build options.

The setting value of the option byte can be checked from the project properties after code generation. Open the project properties (Alt+Enter) and select “C/C++ Build” -> “Settings” to open a “Tool Settings” tab, and select “Linker” -> “Device” and the “User option byte value” and “On-chip debug control value” are displayed.

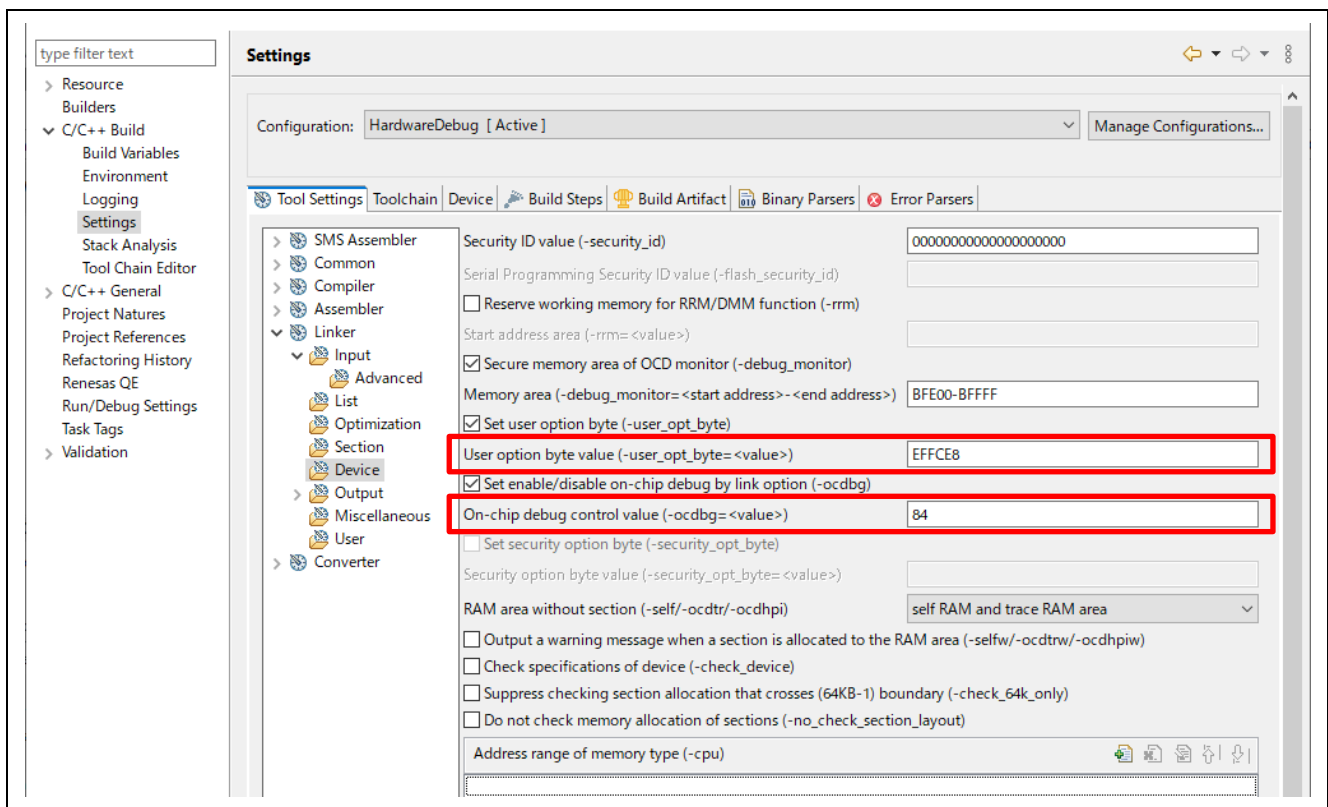

Figure 3-2 User Option Byte Value and On-chip Debug Control Value

3.5 Constants

Table 3-11 lists the constants.

Table 3-11 List of Constant

Constant Name	Setting Value	Description
File Name : qe_touch_sample.c		
TOUCH_SCAN_INTERVAL_EXAMPLE	(20U)	Software delay value [unit: ms]
File Name : r_rssk_switch_led.c		
RSSK_SW1_PORT	(P6_bit.no0)	Pointer to port control register connected to SW1
RSSK_SW2_PORT	(P6_bit.no1)	Pointer to port control register connected to SW2
RSSK_LED1_PORT	(P6_bit.no4)	Pointer to port control register connected to LED1
RSSK_LED2_PORT	(P6_bit.no5)	Pointer to port control register connected to LED2
SW_EDGE_RIZE	(0x07U)	Switch rising judgment
SW_EDGE_FALL	(0x08U)	Switch falling judgment
SW_EDGE_BIT_MASK	(0x0FU)	Switch state judgement mask
RSSK_LED_ON	(0x00U)	Turn on the LED
RSSK_LED_OFF	(0x01U)	Turn off the LED
File Name : r_rssk_touch_led.c		
LED_COL0	(P14_bit.no0)	Pointer to port control register connected to COL0
LED_COL1	(P8_bit.no4)	Pointer to port control register connected to COL1
LED_COL2	(P8_bit.no3)	Pointer to port control register connected to COL2
LED_COL3	(P8_bit.no2)	Pointer to port control register connected to COL3
LED_ROW0	(P2_bit.no1)	Pointer to port control register connected to ROW0
LED_ROW1	(P2_bit.no0)	Pointer to port control register connected to ROW1
LED_ROW2	(P8_bit.no1)	Pointer to port control register connected to ROW2
LED_ROW3	(P8_bit.no0)	Pointer to port control register connected to ROW3
LED_COL_MAX	(4U)	Number of COL signals
LED_COL_ON	(1U)	COL signal ON
LED_COL_OFF	(0U)	COL signal OFF
LED_ROW_OFF	(1U)	ROW signal OFF
SLIDER_LED_NUM	(5U)	Number of slider LED
SLIDER_RESOLUTION	(100U)	Maximum slider touch result
WHEEL_LED_NUM	(8U)	Number of wheel LED
WHEEL_LED_MSB	(1U << (WHEEL_LED_NUM – 1U))	Wheel LED control bit MSB
WHEEL_RESOLUTION_DEGREE	(360U)	Maximum wheel touch result [unit : degree]

List of Constant (Continue)

Constant Name	Setting Value	Description
File Name : r_rssk_touch_led.c		
WHEEL_POSITION_OFFSET_DEGREE	(112U)	Wheel touch position offset [unit : degree]
ALL_LED_NUM	(16U)	Total number of touch electrode board LEDs
LED_TEST_INTERVAL	(100U)	LED lighting interval time [unit: ms]

3.6 Enumerations

Table 3-12 lists the rsk_sw_status_t enum.

Table 3-12 rsk_sw_status_t

Member	Value	Description
File Name : r_rssk_switch_led.h		
RSSK_SW_OFF	0x00	Switch OFF state
RSSK_SW_ON	0x01	Switch OFF state

3.7 Global Variables

Table 3-13 lists the global variables.

Table 3-13 List of Global Variable

Variable Name	Types	Description
File Name : qe_touch_sample.c		
button_status	uint64_t	Button status
slider_position[1]	uint16_t	Slider touch position information
wheel_position[1]	uint16_t	Wheel touch position information
File Name : r_rssk_touch_led.c		
g_led_drive_colmun	uint8_t	Touch electrode board LED drive information
g_button_idx[3]	uint8_t	Button index array

3.8 Functions

Table 3-14 lists the functions.

Table 3-14 List of Function

Function Name	Description
File Name : qe_touch_sample.c	
qe_touch_main	Main function
r_rssk_led_test	LED test processing for Capacitive Touch Evaluation System
r_rssk_initialize	CPU board initialization processing
r_rssk_timer_callback	TAU0 interrupt callback
File Name : r_rssk_switch_led.c	
r_rssk_switch_led_init	CPU board LED initialization processing
r_rssk_switch_led_control	CPU board LED control processing
rssk_get_sw1_status	SW1 state response processing
rssk_get_sw2_status	SW2 state response processing
r_rssk_led1_on	CPU board LED1 turn on
r_rssk_led1_off	CPU board LED1 turn off
r_rssk_led2_on	CPU board LED2 turn on
r_rssk_led2_off	CPU board LED2 turn off
File Name : r_rssk_touch_led.c	
r_rssk_touch_led_test	Touch electrode board LED test pattern processing
r_rssk_touch_led_control	Touch electrode board LED control processing
create_led_bitstring_button	Create Button LED bit strings
create_led_bitstring_wheel	Create Wheel LED bit strings
create_led_bitstring_slider	Create Slider LED bit strings

3.9 Processing Flowchart

Figure 3-3 shows processing flowchart of this software.

- Initialization
 - ① 1. Initial setting of switches / touch electrodes / LEDs, performing LED tests
 2. Touch measurement initial setting, open touch middleware
 3. Timer activation for touch measurement loops
- Touch measurement loop (main loop)
 - ② 1. Touch measurement of buttons, sliders, wheels → Waiting for measurement results
→ Acquisition of measurement results
 2. Software wait (wait 20ms after processing 1.)
- Timer interrupt processing (5ms Interval)
 - ③ LED control of the touch electrode board (The LEDs are configured in a 4x4 matrix, so they are controlled by a dynamic lighting method, with four interrupts per row.)
 - ④ LED control corresponding to the switch on the CPU board (To prevent chattering, the LED will light up if the switch input is judged to be ON three times in a row.)

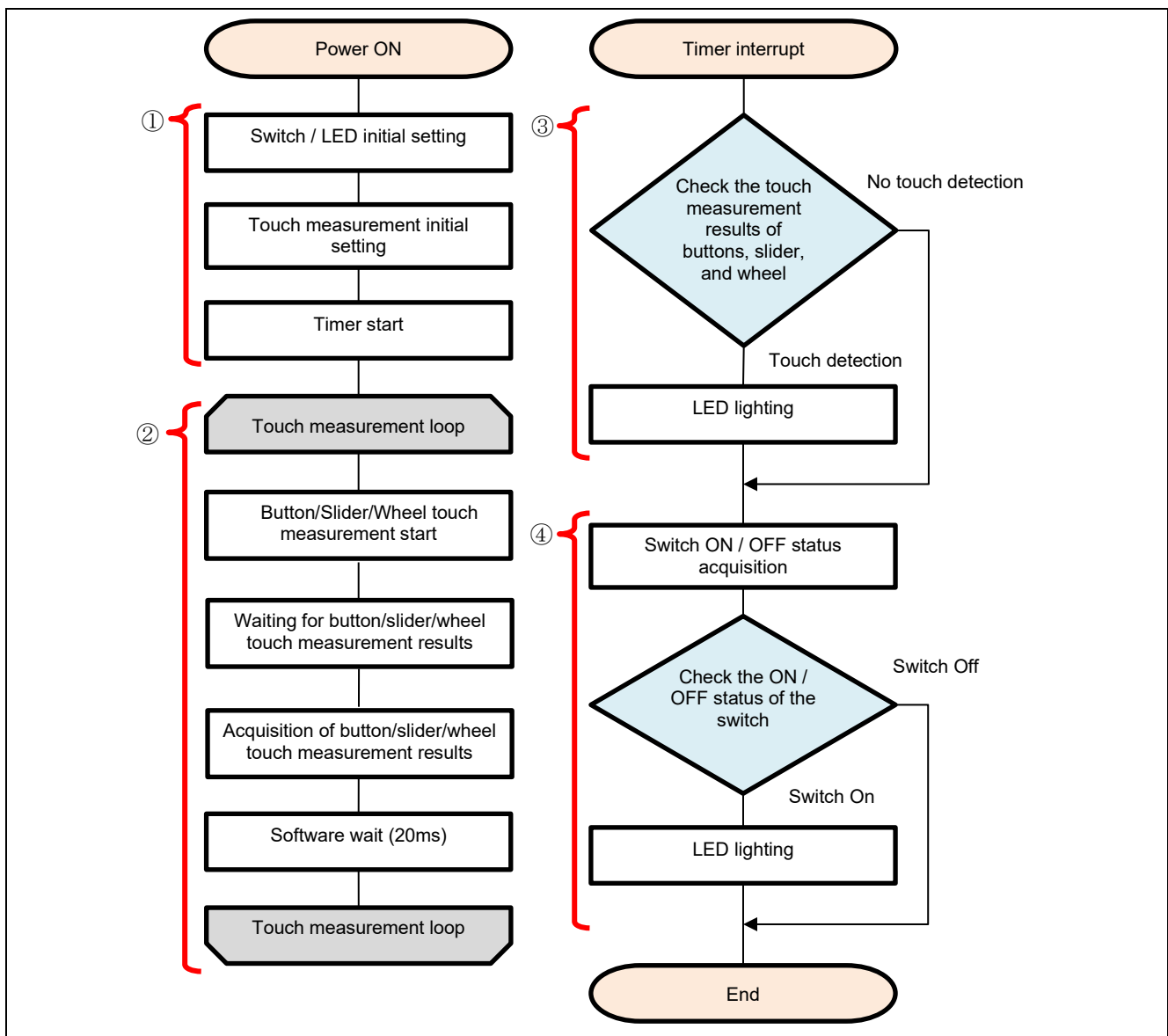

Figure 3-3 Processing Flowchart

4. Capacitive Touch Setting

These are the touch interface configuration, configuration (method) settings and tuning results of this sample code. These use the tuning function of QE.

4.1 Touch Interface Configuration

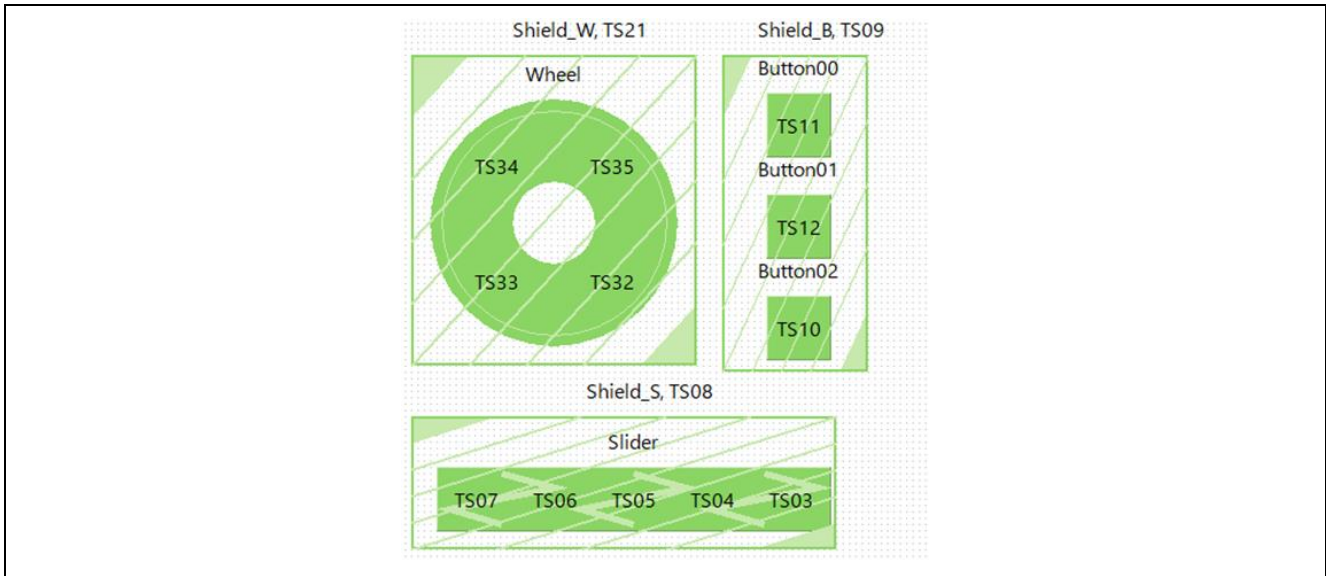

Figure 4-1 Touch interface configuration (Self-Capacitance Buttons / Wheel / Slider Board)

4.2 Configuration (methods) Settings

Figure 4-2 shows configuration (methods) of this sample code. 3 buttons and a shield 0 are set enabled in config01. Slider and a shield 1 are set enabled in config02. Wheel and a shield 2 are set enabled in config02.

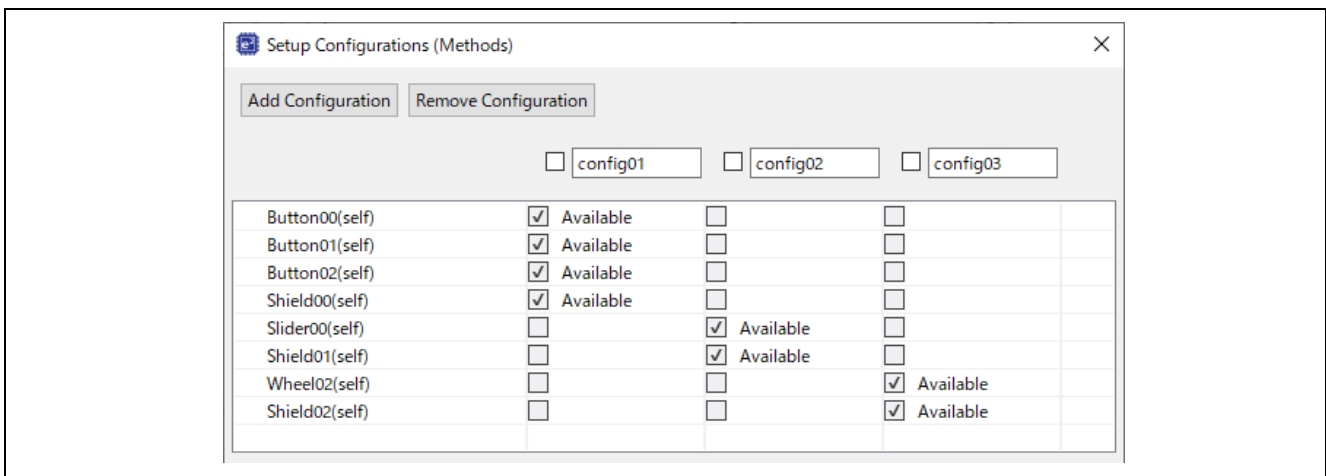

Figure 4-2 Configuration (methods) setting

4.3 Tuning Results

Table 4-1 shows tuning results in QE tuning. Sample code operates with the setting values shown in the QE tuning result list.

Since the values in QE tuning result list depend on the operating environment at QE tuning, these values may change at QE tuning again.

Table 4-1 QE tuning result list (Self-Capacitance Buttons / Wheel / Slider Board)

methods	Button name	Touch sensor	Parasitic capacitance [pF]	Drive pulse frequency [MHz]	Threshold	Scan time [ms]	so	snum	sdpa
config01	Button00	TS11	13.174	0.979 (BASE:1.0)	690	0.576	0x039	0x07	0x0E
config01	Button01	TS12	13.000	0.979 (BASE:1.0)	739	0.576	0x038	0x07	0x0E
config01	Button02	TS10	12.632	0.979 (BASE:1.0)	724	0.576	0x035	0x07	0x0E
config01	Shield00	TS09	50.201	-	-	-	-	-	-
config02	Slider00	TS07	11.847	0.933 (BASE:1.0)	672	0.576	0x033	0x07	0x0E
config02	Slider00	TS06	10.847	0.933 (BASE:1.0)	672	0.576	0x02B	0x07	0x0E
config02	Slider00	TS05	11.181	0.933 (BASE:1.0)	672	0.576	0x02B	0x07	0x0E
config02	Slider00	TS04	11.132	0.933 (BASE:1.0)	672	0.576	0x029	0x07	0x0E
config02	Slider00	TS03	12.264	0.933 (BASE:1.0)	672	0.576	0x030	0x07	0x0E
config02	Shield01	TS08	52.743	-	-	-	-	-	-
config03	Wheel00	TS34	12.764	1.028 (BASE:1.0)	775	0.576	0x043	0x07	0x0D
config03	Wheel00	TS35	12.458	1.028 (BASE:1.0)	775	0.576	0x03F	0x07	0x0D
config03	Wheel00	TS32	13.708	1.028 (BASE:1.0)	775	0.576	0x03C	0x07	0x0D
config03	Wheel00	TS33	13.035	1.028 (BASE:1.0)	775	0.576	0x03B	0x07	0x0D
config03	Shield02	TS21	47.674	-	-	-	-	-	-

so : Variables for sensor offset settings

snum : Variables for setting the measurement period

sdpa : Clock division setting variable

4.4 How to adjust the sensitivity

Button sensitivity adjustment uses QE for Capacitive Touch. The sensitivity adjustment method is as follows.

- The method using monitoring function of QE for Capacitive Touch

Follow the tutorial from the "CapTouch Workflow (QE)" of QE for Capacitive Touch.

- Real-time change method using monitoring function of QE for Capacitive Touch

Display the Cap Touch parameter list of QE for Capacitive Touch and adjust it by the following steps.

1. Select the touch I/F corresponding to the button you want to adjust.
2. Click [Enable Monitoring] icon to start monitoring.
3. When the item is displayed, change the value of [Touch Threshold].
4. Click [Enable Auto Writing] to change the touch threshold.
5. Repeat steps 3 to 4 to adjust the sensitivity.

The settings for steps 1 to 4 above are performed in steps ① to ④ in Figure 4-3

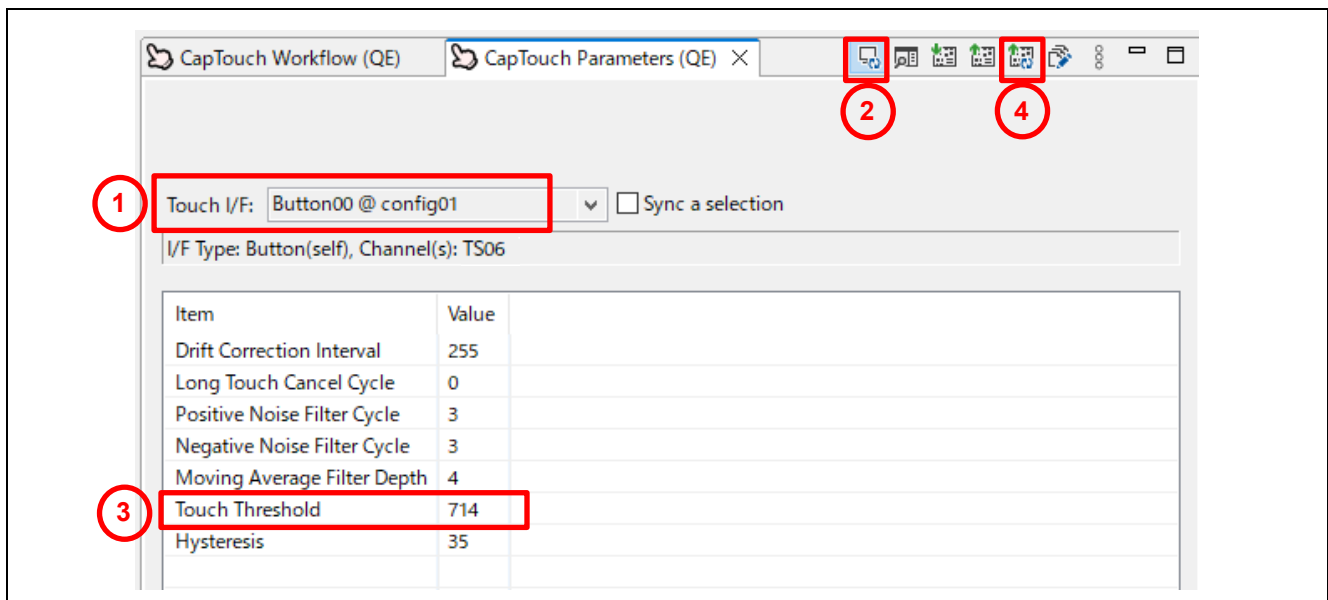

Figure 4-3 Sensitivity adjustment window using the monitoring function

- How to change the code manually

It can be adjusted by changing member variables of structure variable `g_qe_touch_button_cfg_config01` to 03.

The variables to change are:

- `threshold` : Touch detection threshold

QE for Capacitive Touch also supports the Serial Monitor and Serial Tuning features.

For more details on the Serial Monitor and Serial Tuning, please refer to the QE Help and Section 8, "[Additional Feature] Setting Up Serial Communication Monitor Using UART" in [RL78 Family Using QE and SIS to Develop Capacitive Touch Applications Rev.3.00](#).

5. Support

For information on capacitive touch, download tools and documentation, and technical support, please visit the website below.

RL78/L23 Capacitive Touch Evaluation System renesas.com/rssk-touch-rl78l23

Application Note RL78 Family Using QE and SIS to Develop Capacitive Touch Applications (R01AN5512)
renesas.com/en/document/apn/rl78-family-using-qe-and-sis-develop-capacitive-touch-applications

QE for Capacitive Touch renesas.com/qe-capacitive-touch

Renesas Support renesas.com/support

Revision History

Rev.	Date	Description	
		Page	Summary
1.00	Aug.27.25	-	First edition issued

General Precautions in the Handling of Microprocessing Unit and Microcontroller Unit Products

The following usage notes are applicable to all Microprocessing unit and Microcontroller unit products from Renesas. For detailed usage notes on the products covered by this document, refer to the relevant sections of the document as well as any technical updates that have been issued for the products.

1. Precaution against Electrostatic Discharge (ESD)

A strong electrical field, when exposed to a CMOS device, can cause destruction of the gate oxide and ultimately degrade the device operation. Steps must be taken to stop the generation of static electricity as much as possible, and quickly dissipate it when it occurs. Environmental control must be adequate. When it is dry, a humidifier should be used. This is recommended to avoid using insulators that can easily build up static electricity.

Semiconductor devices must be stored and transported in an anti-static container, static shielding bag or conductive material. All test and measurement tools including work benches and floors must be grounded. The operator must also be grounded using a wrist strap. Semiconductor devices must not be touched with bare hands. Similar precautions must be taken for printed circuit boards with mounted semiconductor devices.

2. Processing at power-on

The state of the product is undefined at the time when power is supplied. The states of internal circuits in the LSI are indeterminate and the states of register settings and pins are undefined at the time when power is supplied. In a finished product where the reset signal is applied to the external reset pin, the states of pins are not guaranteed from the time when power is supplied until the reset process is completed. In a similar way, the states of pins in a product that is reset by an on-chip power-on reset function are not guaranteed from the time when power is supplied until the power reaches the level at which resetting is specified.

3. Input of signal during power-off state

Do not input signals or an I/O pull-up power supply while the device is powered off. The current injection that results from input of such a signal or I/O pull-up power supply may cause malfunction and the abnormal current that passes in the device at this time may cause degradation of internal elements. Follow the guideline for input signal during power-off state as described in your product documentation.

4. Handling of unused pins

Handle unused pins in accordance with the directions given under handling of unused pins in the manual. The input pins of CMOS products are generally in the high-impedance state. In operation with an unused pin in the open-circuit state, extra electromagnetic noise is induced in the vicinity of the LSI, an associated shoot-through current flows internally, and malfunctions occur due to the false recognition of the pin state as an input signal become possible.

5. Clock signals

After applying a reset, only release the reset line after the operating clock signal becomes stable. When switching the clock signal during program execution, wait until the target clock signal is stabilized. When the clock signal is generated with an external resonator or from an external oscillator during a reset, ensure that the reset line is only released after full stabilization of the clock signal. Additionally, when switching to a clock signal produced with an external resonator or by an external oscillator while program execution is in progress, wait until the target clock signal is stable.

6. Voltage application waveform at input pin

Waveform distortion due to input noise or a reflected wave may cause malfunction. If the input of the CMOS device stays in the area between V_{IL} (Max.) and V_{IH} (Min.) due to noise, for example, the device may malfunction. Take care to prevent chattering noise from entering the device when the input level is fixed, and also in the transition period when the input level passes through the area between V_{IL} (Max.) and V_{IH} (Min.).

7. Prohibition of access to reserved addresses

Access to reserved addresses is prohibited. The reserved addresses are provided for possible future expansion of functions. Do not access these addresses as the correct operation of the LSI is not guaranteed.

8. Differences between products

Before changing from one product to another, for example to a product with a different part number, confirm that the change will not lead to problems. The characteristics of a microprocessing unit or microcontroller unit products in the same group but having a different part number might differ in terms of internal memory capacity, layout pattern, and other factors, which can affect the ranges of electrical characteristics, such as characteristic values, operating margins, immunity to noise, and amount of radiated noise. When changing to a product with a different part number, implement a system-evaluation test for the given product.

Notice

1. Descriptions of circuits, software and other related information in this document are provided only to illustrate the operation of semiconductor products and application examples. You are fully responsible for the incorporation or any other use of the circuits, software, and information in the design of your product or system. Renesas Electronics disclaims any and all liability for any losses and damages incurred by you or third parties arising from the use of these circuits, software, or information.
2. Renesas Electronics hereby expressly disclaims any warranties against and liability for infringement or any other claims involving patents, copyrights, or other intellectual property rights of third parties, by or arising from the use of Renesas Electronics products or technical information described in this document, including but not limited to, the product data, drawings, charts, programs, algorithms, and application examples.
3. No license, express, implied or otherwise, is granted hereby under any patents, copyrights or other intellectual property rights of Renesas Electronics or others.
4. You shall be responsible for determining what licenses are required from any third parties, and obtaining such licenses for the lawful import, export, manufacture, sales, utilization, distribution or other disposal of any products incorporating Renesas Electronics products, if required.
5. You shall not alter, modify, copy, or reverse engineer any Renesas Electronics product, whether in whole or in part. Renesas Electronics disclaims any and all liability for any losses or damages incurred by you or third parties arising from such alteration, modification, copying or reverse engineering.
6. Renesas Electronics products are classified according to the following two quality grades: "Standard" and "High Quality". The intended applications for each Renesas Electronics product depends on the product's quality grade, as indicated below.

"Standard": Computers; office equipment; communications equipment; test and measurement equipment; audio and visual equipment; home electronic appliances; machine tools; personal electronic equipment; industrial robots; etc.

"High Quality": Transportation equipment (automobiles, trains, ships, etc.); traffic control (traffic lights); large-scale communication equipment; key financial terminal systems; safety control equipment; etc.

Unless expressly designated as a high reliability product or a product for harsh environments in a Renesas Electronics data sheet or other Renesas Electronics document, Renesas Electronics products are not intended or authorized for use in products or systems that may pose a direct threat to human life or bodily injury (artificial life support devices or systems; surgical implantations; etc.), or may cause serious property damage (space system; undersea repeaters; nuclear power control systems; aircraft control systems; key plant systems; military equipment; etc.). Renesas Electronics disclaims any and all liability for any damages or losses incurred by you or any third parties arising from the use of any Renesas Electronics product that is inconsistent with any Renesas Electronics data sheet, user's manual or other Renesas Electronics document.
7. No semiconductor product is absolutely secure. Notwithstanding any security measures or features that may be implemented in Renesas Electronics hardware or software products, Renesas Electronics shall have absolutely no liability arising out of any vulnerability or security breach, including but not limited to any unauthorized access to or use of a Renesas Electronics product or a system that uses a Renesas Electronics product. RENESAS ELECTRONICS DOES NOT WARRANT OR GUARANTEE THAT RENESAS ELECTRONICS PRODUCTS, OR ANY SYSTEMS CREATED USING RENESAS ELECTRONICS PRODUCTS WILL BE INVULNERABLE OR FREE FROM CORRUPTION, ATTACK, VIRUSES, INTERFERENCE, HACKING, DATA LOSS OR THEFT, OR OTHER SECURITY INTRUSION ("Vulnerability Issues"). RENESAS ELECTRONICS DISCLAIMS ANY AND ALL RESPONSIBILITY OR LIABILITY ARISING FROM OR RELATED TO ANY VULNERABILITY ISSUES. FURTHERMORE, TO THE EXTENT PERMITTED BY APPLICABLE LAW, RENESAS ELECTRONICS DISCLAIMS ANY AND ALL WARRANTIES, EXPRESS OR IMPLIED, WITH RESPECT TO THIS DOCUMENT AND ANY RELATED OR ACCOMPANYING SOFTWARE OR HARDWARE, INCLUDING BUT NOT LIMITED TO THE IMPLIED WARRANTIES OF MERCHANTABILITY, OR FITNESS FOR A PARTICULAR PURPOSE.
8. When using Renesas Electronics products, refer to the latest product information (data sheets, user's manuals, application notes, "General Notes for Handling and Using Semiconductor Devices" in the reliability handbook, etc.), and ensure that usage conditions are within the ranges specified by Renesas Electronics with respect to maximum ratings, operating power supply voltage range, heat dissipation characteristics, installation, etc. Renesas Electronics disclaims any and all liability for any malfunctions, failure or accident arising out of the use of Renesas Electronics products outside of such specified ranges.
9. Although Renesas Electronics endeavors to improve the quality and reliability of Renesas Electronics products, semiconductor products have specific characteristics, such as the occurrence of failure at a certain rate and malfunctions under certain use conditions. Unless designated as a high reliability product or a product for harsh environments in a Renesas Electronics data sheet or other Renesas Electronics document, Renesas Electronics products are not subject to radiation resistance design. You are responsible for implementing safety measures to guard against the possibility of bodily injury, injury or damage caused by fire, and/or danger to the public in the event of a failure or malfunction of Renesas Electronics products, such as safety design for hardware and software, including but not limited to redundancy, fire control and malfunction prevention, appropriate treatment for aging degradation or any other appropriate measures. Because the evaluation of microcomputer software alone is very difficult and impractical, you are responsible for evaluating the safety of the final products or systems manufactured by you.
10. Please contact a Renesas Electronics sales office for details as to environmental matters such as the environmental compatibility of each Renesas Electronics product. You are responsible for carefully and sufficiently investigating applicable laws and regulations that regulate the inclusion or use of controlled substances, including without limitation, the EU RoHS Directive, and using Renesas Electronics products in compliance with all these applicable laws and regulations. Renesas Electronics disclaims any and all liability for damages or losses occurring as a result of your noncompliance with applicable laws and regulations.
11. Renesas Electronics products and technologies shall not be used for or incorporated into any products or systems whose manufacture, use, or sale is prohibited under any applicable domestic or foreign laws or regulations. You shall comply with any applicable export control laws and regulations promulgated and administered by the governments of any countries asserting jurisdiction over the parties or transactions.
12. It is the responsibility of the buyer or distributor of Renesas Electronics products, or any other party who distributes, disposes of, or otherwise sells or transfers the product to a third party, to notify such third party in advance of the contents and conditions set forth in this document.
13. This document shall not be reprinted, reproduced or duplicated in any form, in whole or in part, without prior written consent of Renesas Electronics.
14. Please contact a Renesas Electronics sales office if you have any questions regarding the information contained in this document or Renesas Electronics products.

(Note1) "Renesas Electronics" as used in this document means Renesas Electronics Corporation and also includes its directly or indirectly controlled subsidiaries.

(Note2) "Renesas Electronics product(s)" means any product developed or manufactured by or for Renesas Electronics.

(Rev.5.0-1 October 2020)

Corporate Headquarters

TOYOSU FORESIA, 3-2-24 Toyosu,
Koto-ku, Tokyo 135-0061, Japan
www.renesas.com

Trademarks

Renesas and the Renesas logo are trademarks of Renesas Electronics Corporation. All trademarks and registered trademarks are the property of their respective owners.

Contact information

For further information on a product, technology, the most up-to-date version of a document, or your nearest sales office, please visit:
www.renesas.com/contact/.