

## RL78/G24

### TIMER WINDOW Output using Timer RD2, Timer Array Unit and Comparator

---

#### Introduction

This application note explains the TIMER WINDOW output function based on the combined use of the RL78/G24 timer RD2, timer array unit (TAU), and comparator (CMP).

TIMER WINDOW output is a function that sets CMP output to a low level when TAU output (TO02) is at a low level. This means that the TIMER WINDOW output enables voltage detection by the CMP only when TAU output (TO02) is at a high level.

The RL78/G24 allows users to set the valid edge (rising, falling, or both edges) of timer RD2 output (TRDIOxx; xx = B0, C0, D0, A1, B1, C1, D1) as the TAU0 channel 0 start trigger. Thus, when PWM output is performed by timer RD2, the CMP voltage detection period can be set in conjunction with the timer RD2 output.

#### Target Device

RL78/G24

When applying the sample program covered in this application note to another microcomputer, modify the program according to the specifications for the target microcomputer and conduct an extensive evaluation of the modified program.

## Contents

1. Specifications .....	3
1.1 Specification overview .....	3
1.2 Operation overview .....	5
2. Operation Confirmation Conditions .....	9
3. Hardware Description .....	10
3.1 Example of Hardware Configuration .....	10
3.2 List of used Pins .....	10
4. Software Description.....	11
4.1 Smart Configurator Settings .....	11
4.1.1 System Configuration .....	11
4.1.2 Component Configurations.....	13
4.2 Folder Structure.....	17
4.3 List of Option Byte Settings .....	18
4.4 List of Constants .....	18
4.5 List of Global Variables .....	18
4.6 List of Functions .....	18
4.7 Function Specifications .....	18
4.8 Flowchart .....	19
4.8.1 Main Process.....	19
5. Sample Code.....	20
6. Reference Documents .....	20
Revision History .....	21

## 1. Specifications

### 1.1 Specification overview

This section describes the specifications of this application. Timer RD2 is set to the PWM function and outputs PWM from the TRDIOB0 pin with a 30% duty cycle for a period of 300us. TAU is used to execute the one-shot pulse output function with the rising edge of TRDIOB0 as the start trigger. In this application, the delay is set to 10us and the pulse width to 100us.

The comparator (CMP) outputs the comparison results of the IVCOMP1 input voltage and the D/A converter-1 (DAC1) for internal comparator reference voltage as the timer window output through the VCOU1 pin. The D/A converter output is  $VDD \times 512/1024$ .

Table 1-1 provides a list of the peripheral functions used and their purposes, and Figure 1-1 shows the system configuration of the CMP output with the TIMER WINDOW output function.

During the TO02 pulse output period, the VCOU1 output indicated by the dotted circles is not output because the CMP output is masked.

**Table 1-1 Peripheral Functions and Their Usage**

Peripheral	Usage
Timer RD2 (TRD20)	PWM output
Timer Array Unit (TAU)	CMP1 output enable signal output
Comparator (CMP)	Comparator output
D/A Converter 1 (DAC1)	D/A Conversion

**Figure 1-1 System Configuration of CMP Output with the TIMER WINDOW Output Function**

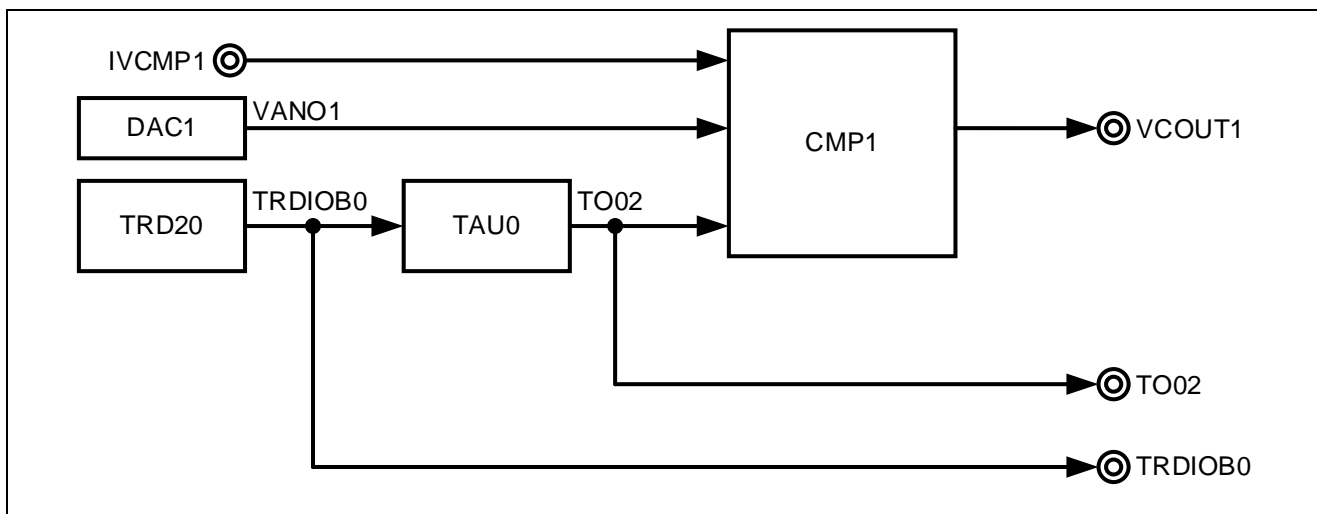
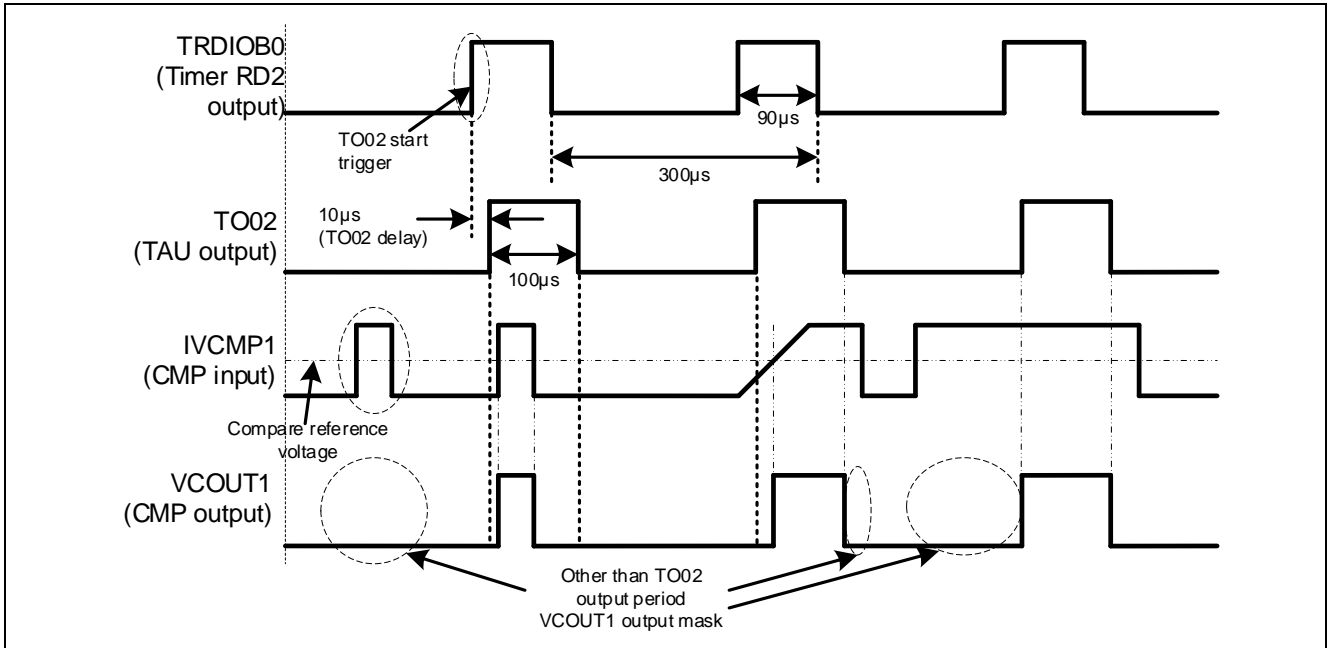

Figure 1-2 shows an example of CMP output using the TIMER WINDOW output.

**Figure 1-2 Output waveform of CMP using TIMER WINDOW Output**



## 1.2 Operation overview

To enable the TIMER WINDOW output, initialization of the TAU, DAC, CMP, and timer RD2 is necessary, and then executing the corresponding operations in the same sequence.

The TAU is set to the one-shot pulse output function. It is triggered by the rising edge of TRDIOB0 with a delay of 10µs and a pulse width setting of 100µs.

### <TAU Initialization>

- Set TAU0\_0 to one-shot pulse output.
- For clock settings, set operating clock to CK00 and clock source to fCLK (48MHz).
- Set the one-shot trigger to external trigger and the rising edge of TRDIOB0.
- Set the one-shot delay to 10µs.
- No interrupt is used.
- Set channel 2 as a slave channel.
- Set the one-shot pulse width to 100µs.
- For output settings, set the initial output value to 0 and output level to active high.
- No interrupt is used.

Figure 1-3 shows the timing of the TAU one-shot pulse output function based on these settings.

**Figure 1-3 Timing of TAU's one-shot pulse output function.**

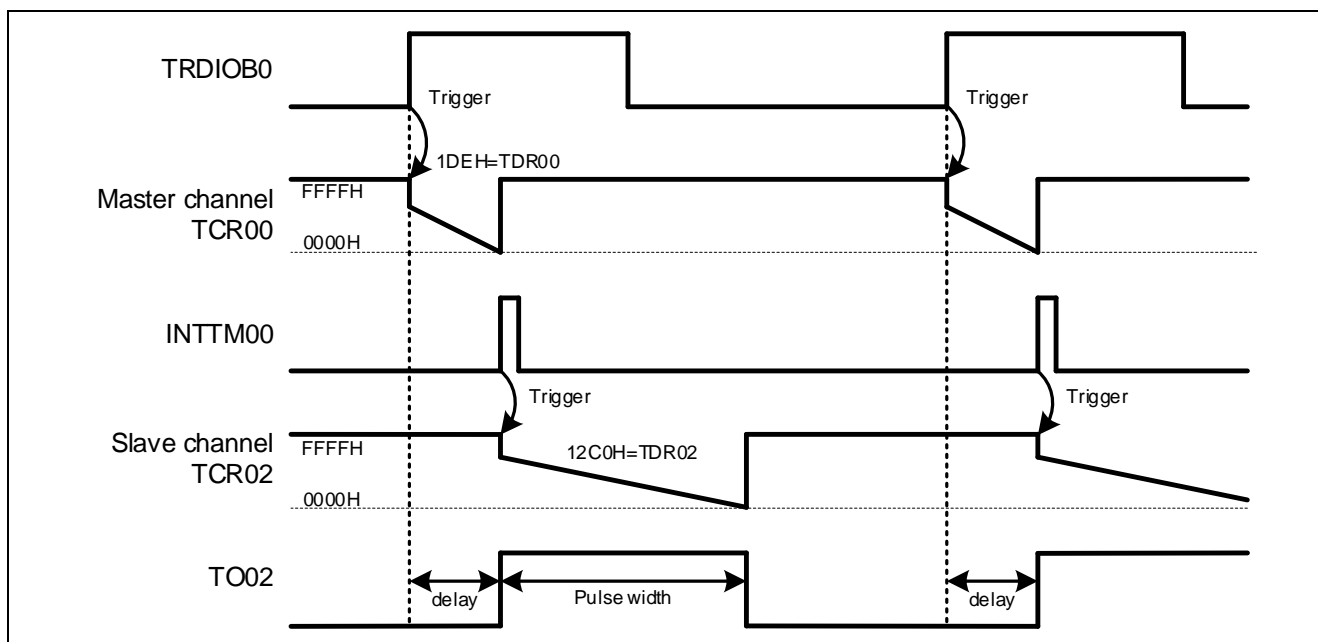

## RL78/G24 TIMER WINDOW Output using Timer RD2, Timer Array Unit and Comparator

The D/A converter uses D/A converter 1, which allows selection of 10-bit resolution.

<DAC Initialization>

- Set analog output to disabled.
- Set the D/A converter resolution to 10 bits.
- Set the D/A converter operation mode to normal mode.
- Set the conversion value to 512 (50%).

Figure 1-4 shows the output timing of the D/A converter based on these settings.

Figure 1-4 D/A Converter Output Timing.

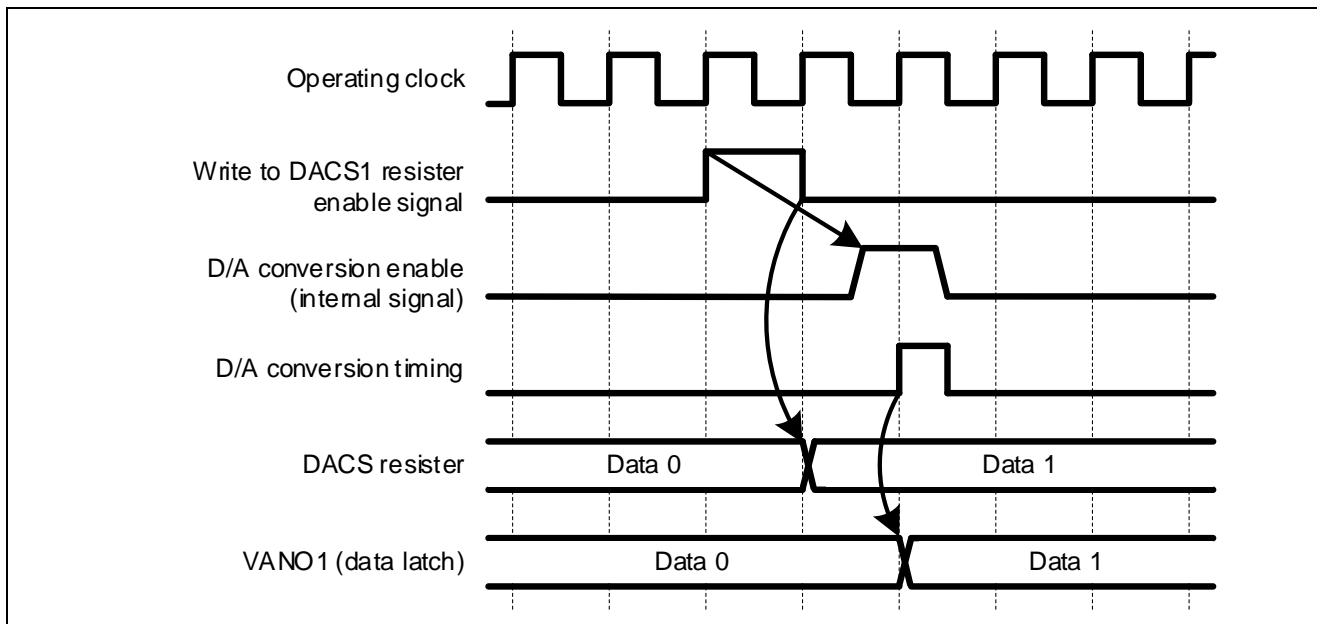

## RL78/G24 TIMER WINDOW Output using Timer RD2, Timer Array Unit and Comparator

The comparator uses Comparator 1.

<CMP Initialization>

- Set the reference voltage to the output of D/A Converter 1. (Refer to the previous page for details).
- Set the edge to rising.
- Set the digital filter to fCLK, fPLL, or fHOCO.
- Enable output from VCOUT1 in TIMER WINDOW output mode.
- No interrupt settings are made.

Figure 1-5 shows the output timing of the comparator based on these settings.

Figure 1-5 Comparator Output Timing.

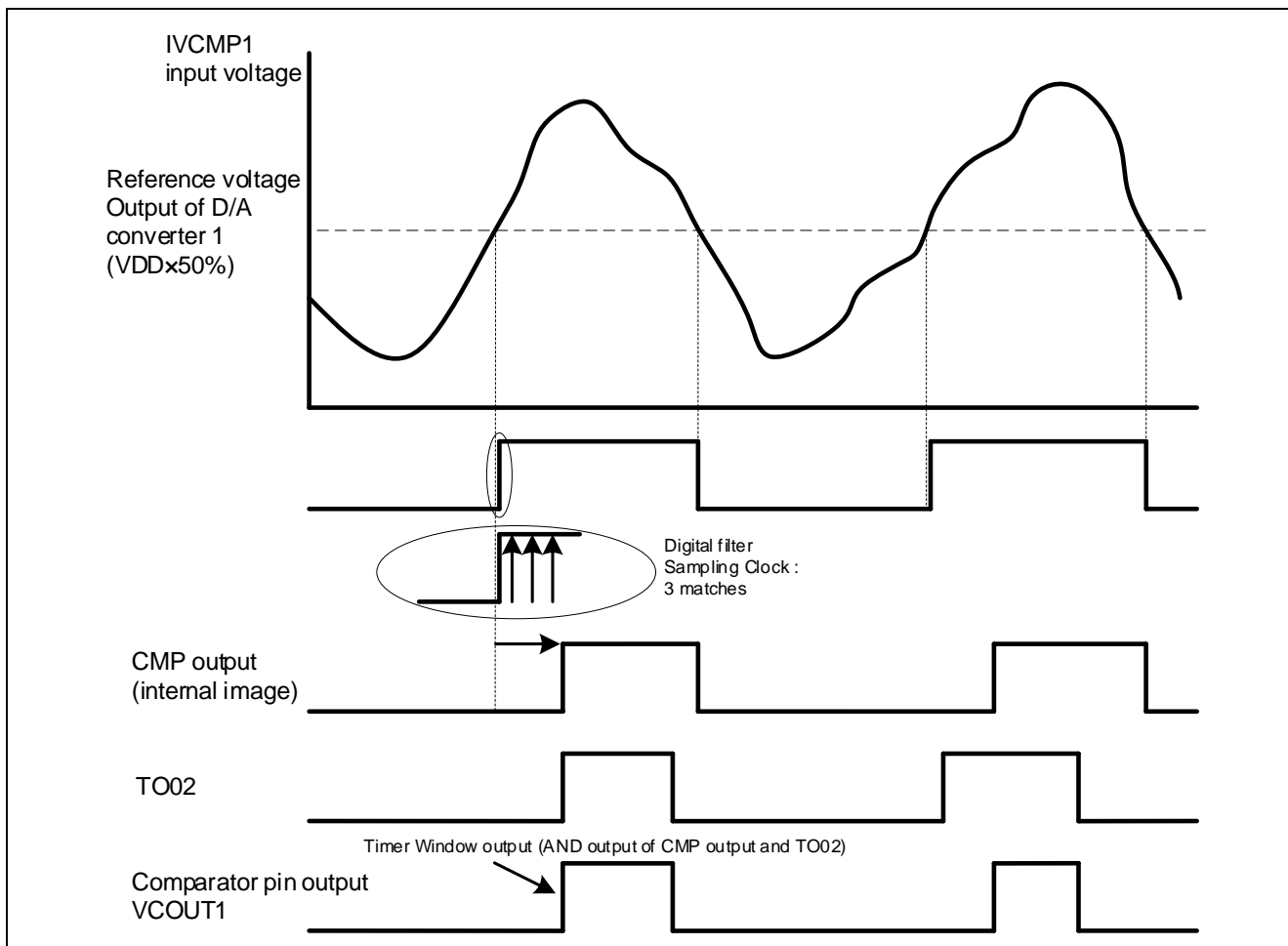

The Timer RD2 is used with the PWM function. It outputs a positive phase with a cycle of 300µs and a duty of 30% from the TRDIOB0 terminal.

< Timer RD2 Initialization >

- Set TRD20 for PWM output.
- Set the count source to fTRD (96MHz).
- Set the counter to continue counting even after matching TRDGRA0.
- Register function settings are set to general registers for both TRDGRD0 and TRDGRC0.
- PWM output settings are configured with a cycle of 300µs and a duty of 30%.
- The initial output of the TRDIOB0 pin is set to inactive level, and the output level is set to H active.
- No settings are made for pulse output force cutoff or interrupts.

Figure 1-6 shows the timing of the PWM output function of Timer RD2 based on these settings.

Figure 1-6 Timing of the Timer RD2 PWM Output Function.

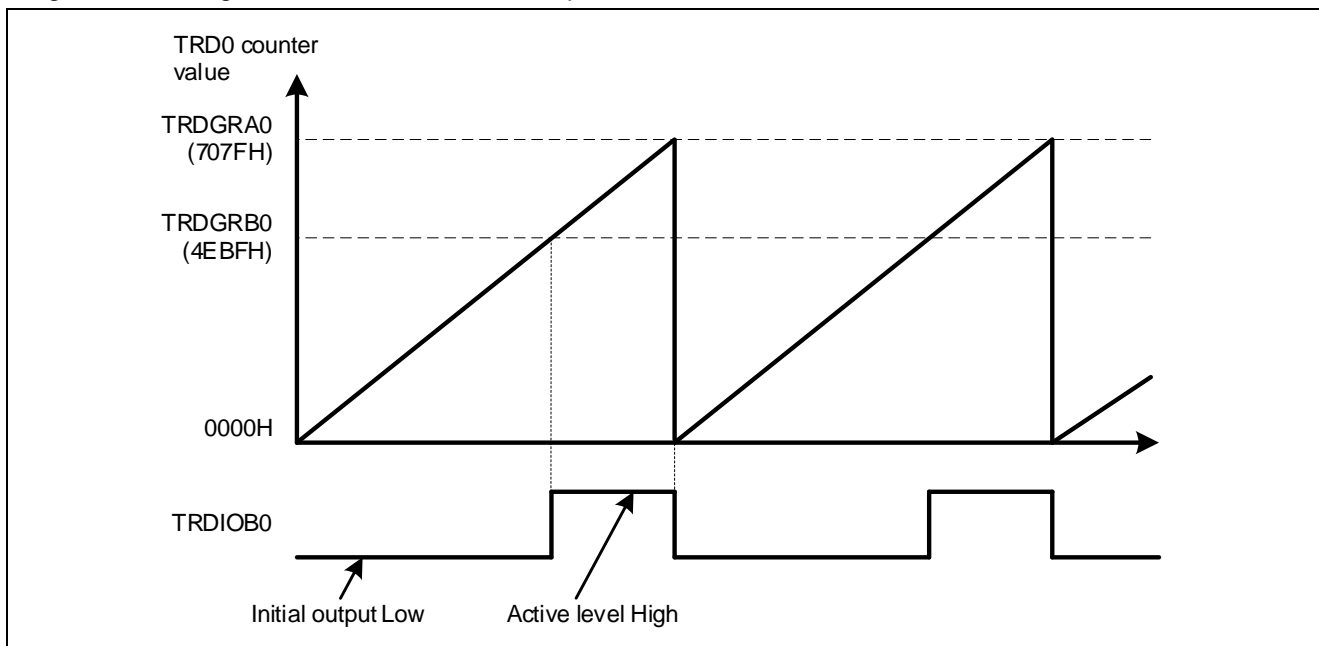



## 2. Operation Confirmation Conditions

The sample code described in this application note has been confirmed under the following conditions.

**Table 2-1 Operation Confirmation Conditions**

Item	Description
MCU used	RL78/G24 (R7F101GLG)
Operating frequency	<ul style="list-style-type: none"> <li>· High-Speed On-Chip Oscillator Clock (fHOCO): 8MHz</li> <li>· PLL Oscillator Circuit Output (fPLL): 96MHz</li> <li>· CPU/Peripheral Hardware Clock (fCLK): 48MHz</li> </ul>
Operating voltage	<ul style="list-style-type: none"> <li>· 3.3V (Can operate between 2.7V to 5.5V)</li> <li>· LVD0 Operation (VLVD0): Reset Mode Rising edge = 2.97V Falling edge = 2.91V</li> </ul>
Integrated development environment (CS+)	CS+ for CC V8.10.00 Manufactured by Renesas Electronics
C compiler (CS+)	CC-RL V1.12.01 Manufactured by Renesas Electronics
Integrated development environment (e <sup>2</sup> studio)	e <sup>2</sup> studio 2023-07 (23.7.0) Manufactured by Renesas Electronics
C compiler (e <sup>2</sup> studio)	CC-RL V1.12.00 Manufactured by Renesas Electronics
Integrated development Environment (IAR)	IAR Embedded Workbench for Renesas RL78 V4.21.1 Manufactured by IAR Systems
C compiler (IAR)	
Smart Configurator	V.1.7.0
Board Support Package (r_bsp)	V.1.60
Emulator	CS+, e <sup>2</sup> studio: COM port IAR: E2 Emulator Lite
Board used	RL78/G24 Fast Prototyping Board (RTK7RLG240C00000BJ)

### 3. Hardware Description

#### 3.1 Example of Hardware Configuration

Figure 3-1 shows the hardware configuration example used in the sample code for this application.

Figure 3-1 Example of Hardware Configuration

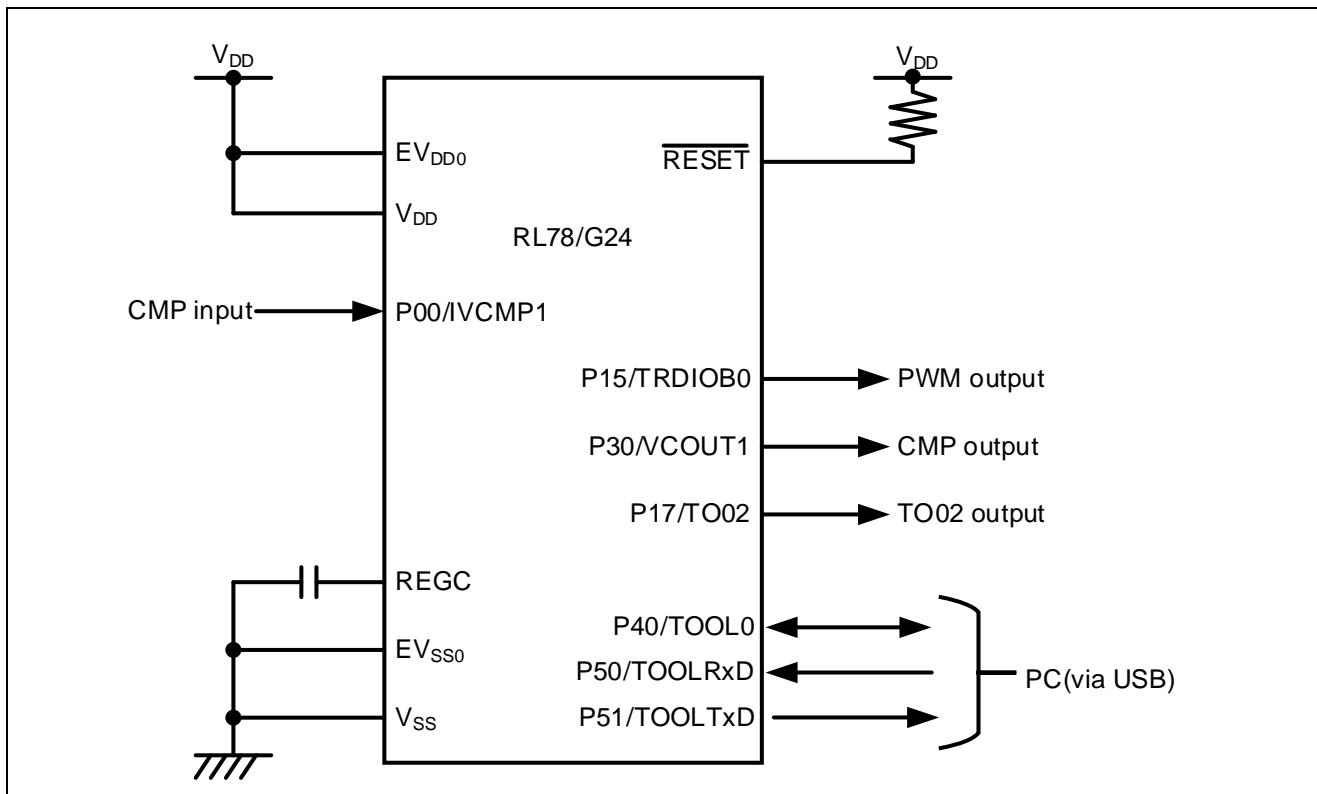

Note 1. This simplified circuit diagram was created to show an overview of connections only. When actually designing your circuit, make sure the design includes appropriate pin handling and meets electrical characteristic requirements (connect each input-only port to VDD or VSS through a resistor).

Note 2. Connect any pins whose name begins with EVSS to VSS, and any pins whose name begins with EVDD to VDD, respectively.

Note 3. VDD must not be lower than the reset release voltage (VLVD0) that is specified for the LVD0.

#### 3.2 List of used Pins

Table 3-1 shows the pins used and their functions.

Table 3-1 Pins Used and Their Functions

Pin name	I/O	Function
P15/TRDIOB0	Output	PWM output
P00/IVCMP1	Input	Comparator 1 positive side input
P30/VCOUT1	Output	Comparator 1 comparison result output
P17/TO02	Output	TO02 output

Caution: In this application note, only the used pins are processed. When actually designing your circuit, make sure the design includes sufficient pin processing and meets electrical characteristic requirements.

## 4. Software Description

### 4.1 Smart Configurator Settings

This section presents the settings of the Smart Configurator used in this sample program. The items and settings in each table for the Smart Configurator are described as they appear in the configuration screen.

#### 4.1.1 System Configuration

The system configuration used in this sample program are shown below.

Note that the system settings used in this sample program are the same for the integrated development environments e2 studio and CS+, but different for IAR. Please adjust the settings appropriately according to the environment you are using.

Firstly, Figure 4-1 shows the system configuration used in this sample program (for e2 studio and CS+).

If you are conducting a COM port debug on the RL78/G24 Fast Prototyping Board (RTK7RLG240C00000BJ), it is necessary to set the integrated development environments (e2 studio and CS+) appropriately. For details, please refer to the "RL78/G24 Fast Prototyping Board User's Manual (R20UT5091)", specifically "7.1 Using COM Port Debugging with the e<sup>2</sup> studio" and "7.2 Using COM Port Debugging in CS+".

Figure 4-1 System Configuration (e<sup>2</sup> studio, CS+)

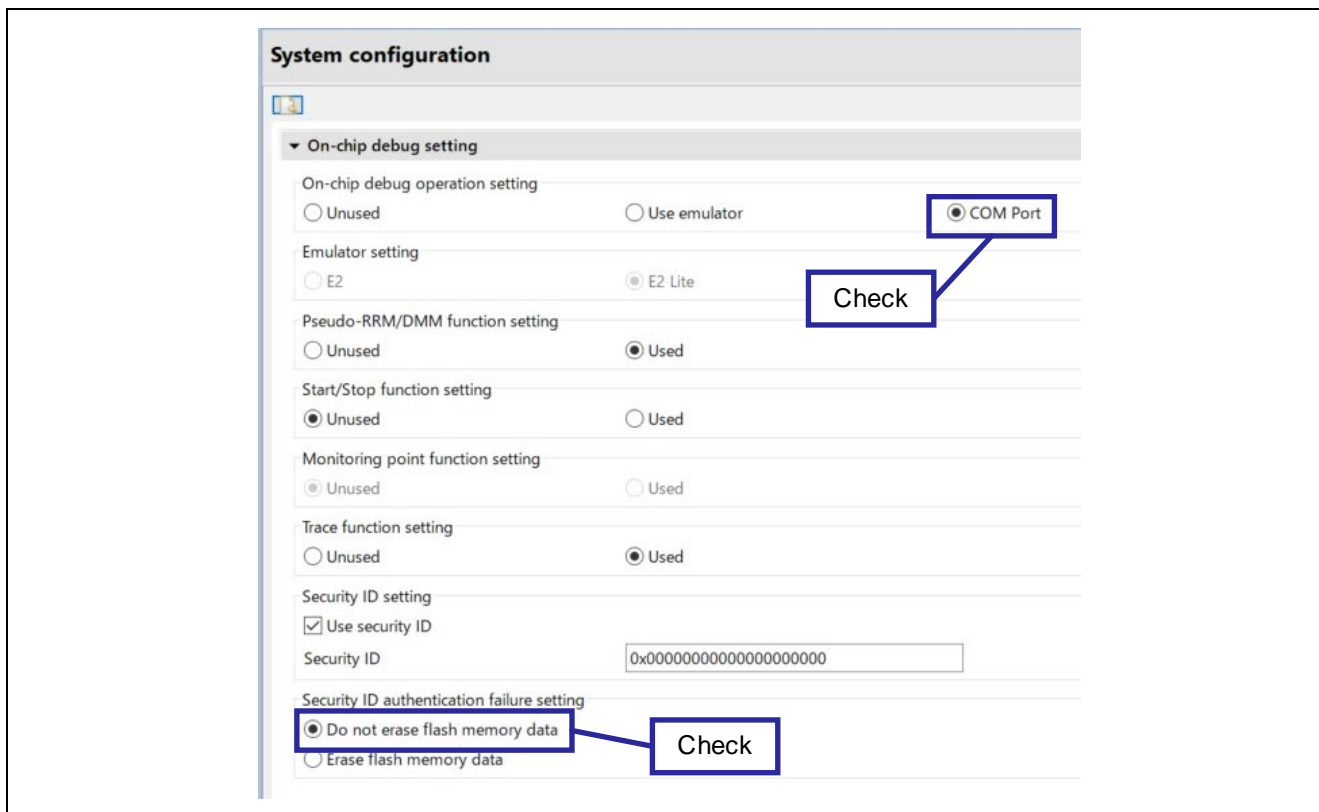
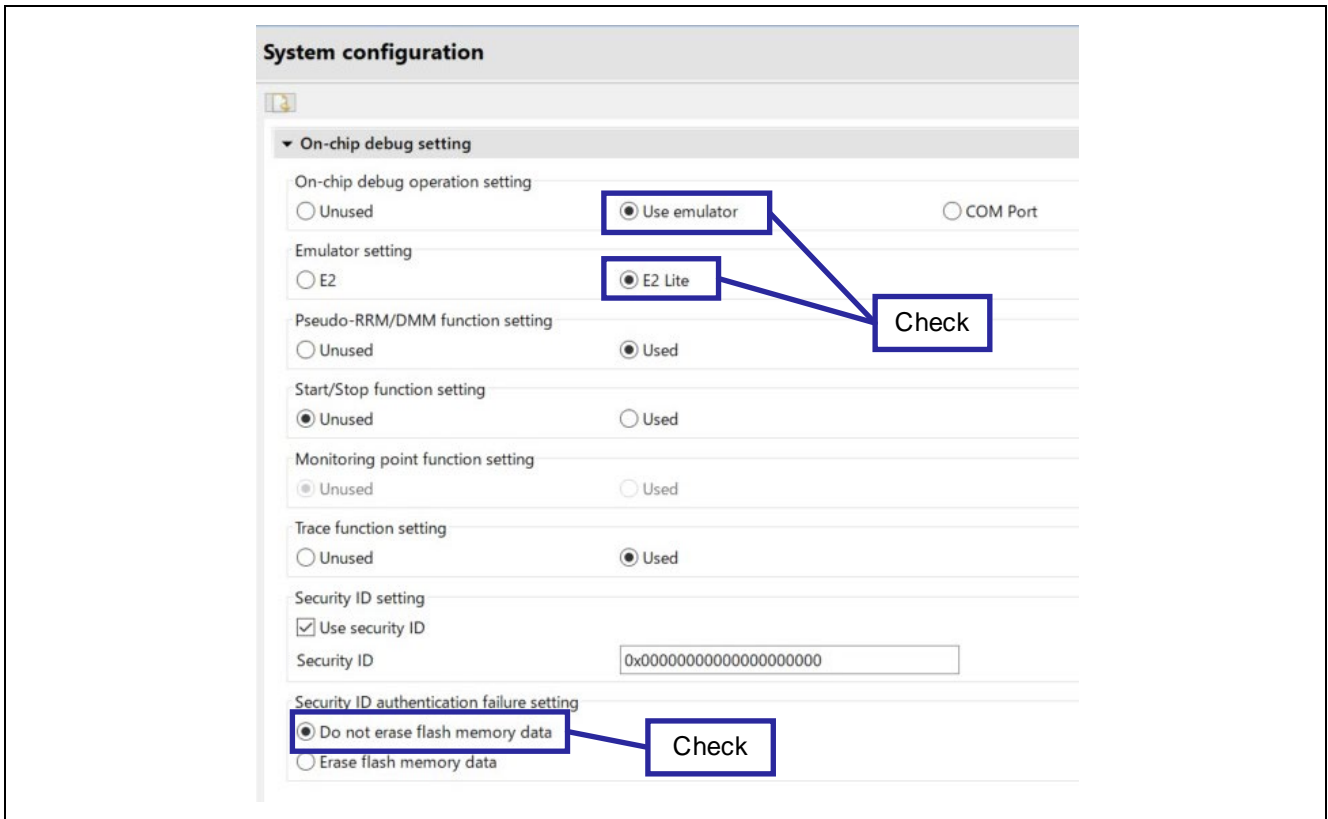

Figure 4-2 shows the system configurations used in this sample program for IAR.

**Figure 4-2 System Configurations (IAR)**



### 4.1.2 Component Configurations

This section presents the component configurations used in this sample program.

**Table 4-1 Component Configurations (TAU)**

Item	Content
Component	One-shot Pulse Output
Configuration Name	Config_TAU0_0
Resource	TAU0_0

**Figure 4-3 Configuration of TAU0\_0**

The screenshot shows the configuration interface for TAU0\_0. Key settings and annotations are as follows:

- Clock setting:** Operation clock is CK00, Clock source is fCLK (48000 kHz).
- One-shot trigger setting:** External trigger is selected (checked). Input source is TRDIOB0. TI00 input edge selection is Rising edge.
- One-shot delay time setting:** Delay time is 10 μs.
- Interrupt setting:** End of timer channel 0 count, generate an interrupt (INTTM00) is unchecked. Priority is Level 3 (low).
- One-shot slave select setting:** Channel 2 slave is selected (checked).
- One-shot slave setting (Slave2):** One-shot pulse width setting: Pulse width is 100 μs. Output setting: Output disabled (Fixed to L) is unchecked. Initial output value is 0. Output level is Active-high.
- Interrupt setting (Slave2):** End of timer channel 2 count, generate an interrupt (INTTM02) is unchecked. Priority is Level 3 (low).

**Table 4-2 Component Configurations (D/A Converter)**

Item	Content
Component	D/A Converter
Configuration Name	Config_DAC1
Resource	DAC1

**Figure 4-4 Configuration of D/A Converter**

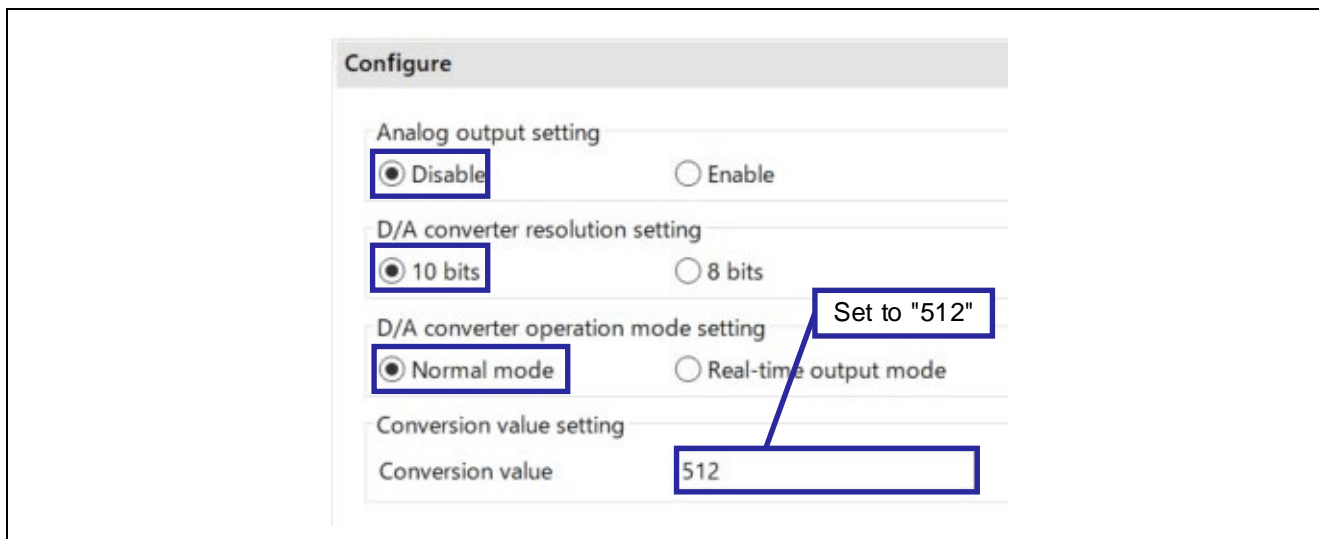

Table 4-3 Component Configurations (Comparator)

Item	Content
Component	Comparator
Configuration Name	Config_COMP1
Resource	COMP1

Figure 4-5 Configuration of COMP1

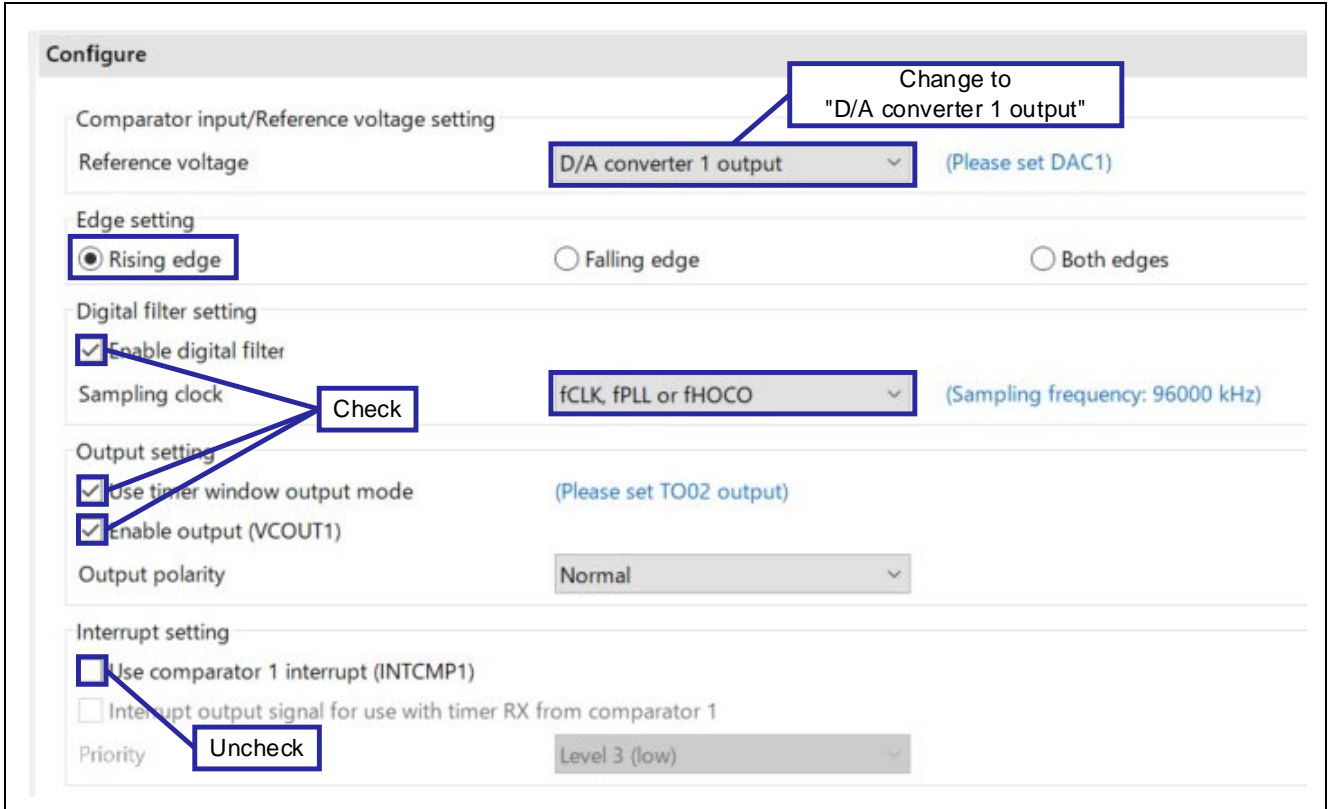

Table 4-4 Component Configurations (Timer RD2)

Item	Content
Component	PWM output
Configuration Name	Config_TRD0
Resource	PWM function
Component	TRD0

Figure 4-6 Configuration of TRD20

The screenshot shows the configuration page for TRD20. Key settings and annotations are as follows:

- Count source setting:** Clock source is set to **fTRD**. (Clock frequency: 96000 kHz, fPLL is selected as fTRD)
- Counter setting:** Counter operation is set to **Count continues after TRDGRA0 compare match**.
- Register function setting:** TRDGRC0 and TRDGRD0 are both set to **General register**.
- PWM output setting:**
  - PWM period is set to **300**  $\mu$ s. (Actual value: 300)
  - TRDGRB0 Duty is set to **30** (%). (Actual value: 30%)
  - TRDGRD0 Duty is set to **50** (%). (Actual value: 50%)
  - TRDGRD0 Duty is set to **50** (%). (Actual value: 50%)
- Output setting:**
  - TRDIOB0 pin: Initial output is **Non-active level**, Output level is **"H" active**.
  - TRDIOC0 pin: Initial output is **Non-active level**, Output level is **"L" active**.
  - TRDIOD0 pin: Initial output is **Non-active level**, Output level is **"L" active**.
- Pulse output forced cutoff setting:**
  - Enable forced cutoff by INTPO low-level input:
  - Enable forced cutoff by ELC event input:
  - TRDIOB0 pin output: **Forced cutoff disabled**
  - TRDIOC0 pin output: **Forced cutoff disabled**
  - TRDIOD0 pin output: **Forced cutoff disabled**
- Interrupt setting:**
  - Enable TRDGRA0 compare match interrupt:  (Uncheck)
  - Enable TRDGRB0 compare match interrupt:  (Uncheck)
  - Enable TRDGRC0 compare match interrupt:
  - Enable TRDGRD0 compare match interrupt:
  - Enable TRD0 overflow interrupt:  (Uncheck)
  - INTRD0 priority: **Level 3 (low)**



## 4.2 Folder Structure

Table 4-5 shows the structure of the source files/header files used in the sample code. Note that files automatically generated by the integrated development environment and files from the BSP environment are excluded.

**Table 4-5 Folder Structure**

Folder/File Name	Description	Generated by Smart Configurator
\r01an6784_timer_comp<DIR> <sup>NOTE 2</sup>	Sample project folder	
\src<DIR>	Program storage folder	
main.c	Sample Code Source File	
\smc_gen<DIR>	Smart Configurator Generated Folder	√
\Config_COMP1<DIR>	Program Storage Folder for COMP1	√
Config_COMP1.c	Source File for COMP1	√
Config_COMP1.h	Header File for COMP1	√
Config_COMP1_user.c	Interrupt Source File for COMP1	√ <sup>NOTE 1</sup>
\Config_DAC1<DIR>	Program Storage Folder for DAC1	√
Config_DAC1.c	Source File for DAC1	√
Config_DAC1.h	Header File for DAC1	√
Config_DAC1_user.c	Interrupt Source File for DAC1	√ <sup>NOTE 1</sup>
\Config_TAU0_0<DIR>	Program Storage Folder for TAU00	√
Config_TAU0_0.c	Source File for TAU00	√
Config_TAU0_0.h	Header File for TAU00	√
Config_TAU0_0_user.c	Interrupt Source File for TAU00	√ <sup>NOTE 1</sup>
\Config_TRD0<DIR>	Program Storage Folder for TRD20	√
Config_TRD0.c	Source File for TRD20	√
Config_TRD0.h	Header File for TRD20	√
Config_TRD0_user.c	Interrupt Source File for TRD20	√ <sup>NOTE 1</sup>
¥general<DIR>	Initialization, Common Program Storage Folder	√
¥r_bsp<DIR>	BSP Program Storage Folder	√
¥r_config<DIR>	Configuration Program Storage Folder	√

Note: "<DIR>" indicates a directory.

Note 1: Not used in the sample code.

Note 2: The sample code for IAR contains the r01an6784\_timer\_comp.ipcf file.

For details on the .ipcf file, please refer to "RL78 Smart Configurator User's Guide: IAR (R20AN0581).

### 4.3 List of Option Byte Settings

Table 4-6 shows the option byte settings.

Table 4-6 Option Byte Settings

Address	Setting Value	Description
000C0H/040C0H	1110 1111B (EFH)	Watchdog Timer stopped operation (Count stops after reset release)
000C1H/040C1H	1111 1011B (FBH)	LVD0 reset mode. Detection voltage: Rising 2.97V / Falling 2.91V
000C2H/040C2H	1110 1010B (EAH)	Flash operation mode: High-speed main mode. High-speed on-chip oscillator frequency: 8MHz
000C3H/040C3H	1000 0101B (85H)	On-chip debug operation allowed

### 4.4 List of Constants

The sample code does not use any constants.

### 4.5 List of Global Variables

The sample code does not use any global variables.

### 4.6 List of Functions

Table 4-7 lists the functions used in the sample code. However, functions generated by the Smart Configurator that have not been modified are excluded.

Table 4-7 List of Functions

Function Name	Description	Source File
main	Main process	main.c

### 4.7 Function Specifications

The function specifications of the sample code are presented.

[Function Name] main

<b>Outline</b>	Main process
<b>Header</b>	r_smc_entry.h
<b>Declaration</b>	void main (void);
<b>Explanation</b>	Initialize the operation of TAU0 channel 0, channel 2, DAC1, CMP1, and timer RD20.
<b>Arguments</b>	-
<b>Return value</b>	-
<b>Remarks</b>	-

## 4.8 Flowchart

### 4.8.1 Main Process

Figure 4-7 shows the flowchart for the main process.

Figure 4-7 Main Process

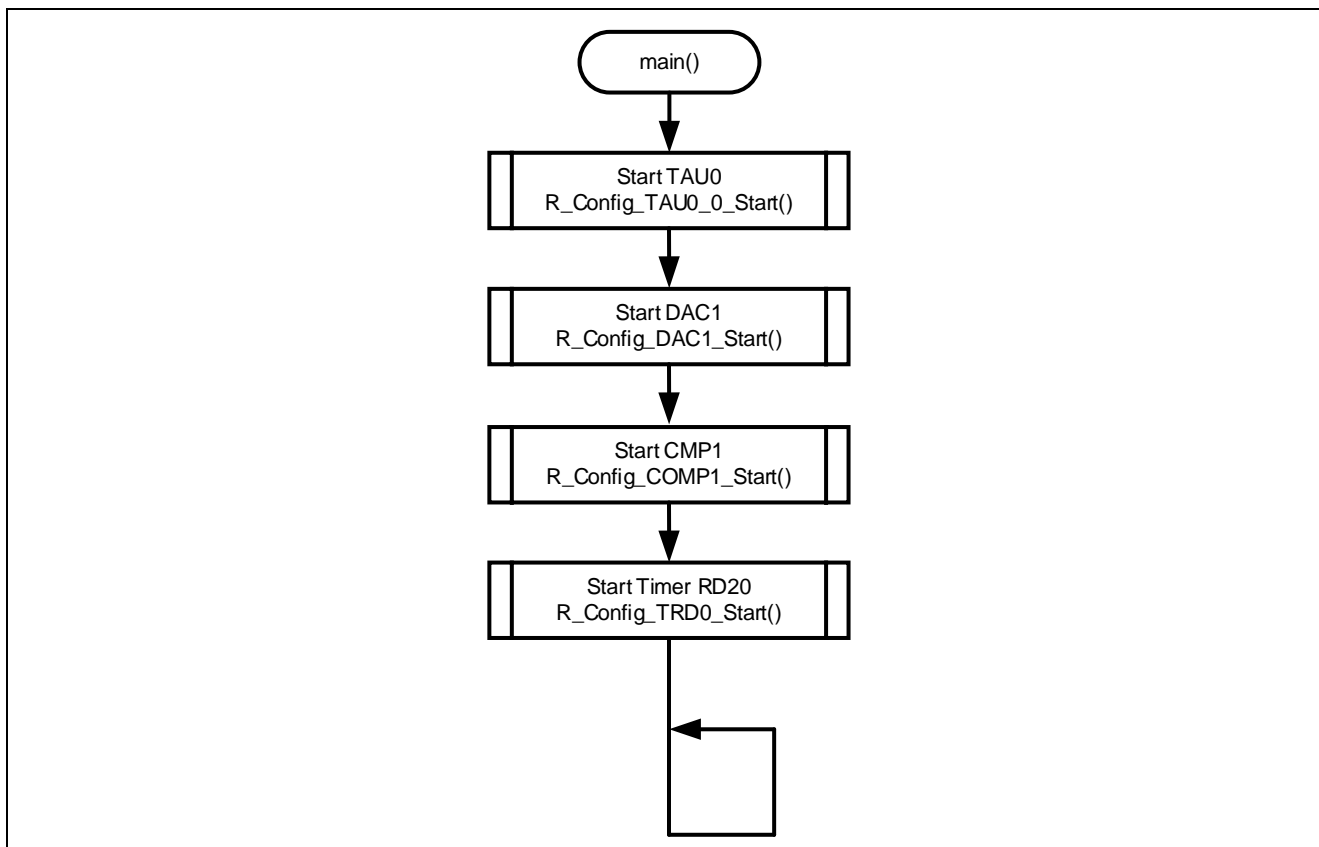

## **5. Sample Code**

Sample code can be downloaded from the Renesas Electronics website.

## **6. Reference Documents**

RL78/G24 User's Manual: Hardware (R01UH0961)

RL78 family User's Manual: Software (R01US0015)

RL78/G24 Fast Prototyping Board User's Manual (R20UT5091)

RL78 Smart Configurator User's Guide: CS+ (R20AN0580)

RL78 Smart Configurator User's Guide: e2 studio (R20AN0579)

RL78 Smart Configurator User's Guide: IAR (R20AN0581)

(The latest version can be downloaded from the Renesas Electronics website.)

Technical Update/Technical News

(The latest version can be downloaded from the Renesas Electronics website.)

## **Website and Support**

**Renesas Electronics Website**

<http://www.renesas.com/>

**Inquiries**

<http://www.renesas.com/contact/>

All trademarks and registered trademarks are the property of their respective owners.

**Revision History**

Rev.	Date	Description	
		Page	Summary
1.00	Sep.07.23	-	First Edition

## General Precautions in the Handling of Microprocessing Unit and Microcontroller Unit Products

The following usage notes are applicable to all Microprocessing unit and Microcontroller unit products from Renesas. For detailed usage notes on the products covered by this document, refer to the relevant sections of the document as well as any technical updates that have been issued for the products.

### 1. Precaution against Electrostatic Discharge (ESD)

A strong electrical field, when exposed to a CMOS device, can cause destruction of the gate oxide and ultimately degrade the device operation. Steps must be taken to stop the generation of static electricity as much as possible, and quickly dissipate it when it occurs. Environmental control must be adequate. When it is dry, a humidifier should be used. This is recommended to avoid using insulators that can easily build up static electricity.

Semiconductor devices must be stored and transported in an anti-static container, static shielding bag or conductive material. All test and measurement tools including work benches and floors must be grounded. The operator must also be grounded using a wrist strap. Semiconductor devices must not be touched with bare hands. Similar precautions must be taken for printed circuit boards with mounted semiconductor devices.

### 2. Processing at power-on

The state of the product is undefined at the time when power is supplied. The states of internal circuits in the LSI are indeterminate and the states of register settings and pins are undefined at the time when power is supplied. In a finished product where the reset signal is applied to the external reset pin, the states of pins are not guaranteed from the time when power is supplied until the reset process is completed. In a similar way, the states of pins in a product that is reset by an on-chip power-on reset function are not guaranteed from the time when power is supplied until the power reaches the level at which resetting is specified.

### 3. Input of signal during power-off state

Do not input signals or an I/O pull-up power supply while the device is powered off. The current injection that results from input of such a signal or I/O pull-up power supply may cause malfunction and the abnormal current that passes in the device at this time may cause degradation of internal elements. Follow the guideline for input signal during power-off state as described in your product documentation.

### 4. Handling of unused pins

Handle unused pins in accordance with the directions given under handling of unused pins in the manual. The input pins of CMOS products are generally in the high-impedance state. In operation with an unused pin in the open-circuit state, extra electromagnetic noise is induced in the vicinity of the LSI, an associated shoot-through current flows internally, and malfunctions occur due to the false recognition of the pin state as an input signal become possible.

### 5. Clock signals

After applying a reset, only release the reset line after the operating clock signal becomes stable. When switching the clock signal during program execution, wait until the target clock signal is stabilized. When the clock signal is generated with an external resonator or from an external oscillator during a reset, ensure that the reset line is only released after full stabilization of the clock signal. Additionally, when switching to a clock signal produced with an external resonator or by an external oscillator while program execution is in progress, wait until the target clock signal is stable.

### 6. Voltage application waveform at input pin

Waveform distortion due to input noise or a reflected wave may cause malfunction. If the input of the CMOS device stays in the area between  $V_{IL}$  (Max.) and  $V_{IH}$  (Min.) due to noise, for example, the device may malfunction. Take care to prevent chattering noise from entering the device when the input level is fixed, and also in the transition period when the input level passes through the area between  $V_{IL}$  (Max.) and  $V_{IH}$  (Min.).

### 7. Prohibition of access to reserved addresses

Access to reserved addresses is prohibited. The reserved addresses are provided for possible future expansion of functions. Do not access these addresses as the correct operation of the LSI is not guaranteed.

### 8. Differences between products

Before changing from one product to another, for example to a product with a different part number, confirm that the change will not lead to problems. The characteristics of a microprocessing unit or microcontroller unit products in the same group but having a different part number might differ in terms of internal memory capacity, layout pattern, and other factors, which can affect the ranges of electrical characteristics, such as characteristic values, operating margins, immunity to noise, and amount of radiated noise. When changing to a product with a different part number, implement a system-evaluation test for the given product.

## Notice

1. Descriptions of circuits, software and other related information in this document are provided only to illustrate the operation of semiconductor products and application examples. You are fully responsible for the incorporation or any other use of the circuits, software, and information in the design of your product or system. Renesas Electronics disclaims any and all liability for any losses and damages incurred by you or third parties arising from the use of these circuits, software, or information.
2. Renesas Electronics hereby expressly disclaims any warranties against and liability for infringement or any other claims involving patents, copyrights, or other intellectual property rights of third parties, by or arising from the use of Renesas Electronics products or technical information described in this document, including but not limited to, the product data, drawings, charts, programs, algorithms, and application examples.
3. No license, express, implied or otherwise, is granted hereby under any patents, copyrights or other intellectual property rights of Renesas Electronics or others.
4. You shall be responsible for determining what licenses are required from any third parties, and obtaining such licenses for the lawful import, export, manufacture, sales, utilization, distribution or other disposal of any products incorporating Renesas Electronics products, if required.
5. You shall not alter, modify, copy, or reverse engineer any Renesas Electronics product, whether in whole or in part. Renesas Electronics disclaims any and all liability for any losses or damages incurred by you or third parties arising from such alteration, modification, copying or reverse engineering.
6. Renesas Electronics products are classified according to the following two quality grades: "Standard" and "High Quality". The intended applications for each Renesas Electronics product depends on the product's quality grade, as indicated below.
  - "Standard": Computers; office equipment; communications equipment; test and measurement equipment; audio and visual equipment; home electronic appliances; machine tools; personal electronic equipment; industrial robots; etc.
  - "High Quality": Transportation equipment (automobiles, trains, ships, etc.); traffic control (traffic lights); large-scale communication equipment; key financial terminal systems; safety control equipment; etc.

Unless expressly designated as a high reliability product or a product for harsh environments in a Renesas Electronics data sheet or other Renesas Electronics document, Renesas Electronics products are not intended or authorized for use in products or systems that may pose a direct threat to human life or bodily injury (artificial life support devices or systems; surgical implantations; etc.), or may cause serious property damage (space system; undersea repeaters; nuclear power control systems; aircraft control systems; key plant systems; military equipment; etc.). Renesas Electronics disclaims any and all liability for any damages or losses incurred by you or any third parties arising from the use of any Renesas Electronics product that is inconsistent with any Renesas Electronics data sheet, user's manual or other Renesas Electronics document.
7. No semiconductor product is absolutely secure. Notwithstanding any security measures or features that may be implemented in Renesas Electronics hardware or software products, Renesas Electronics shall have absolutely no liability arising out of any vulnerability or security breach, including but not limited to any unauthorized access to or use of a Renesas Electronics product or a system that uses a Renesas Electronics product. RENESAS ELECTRONICS DOES NOT WARRANT OR GUARANTEE THAT RENESAS ELECTRONICS PRODUCTS, OR ANY SYSTEMS CREATED USING RENESAS ELECTRONICS PRODUCTS WILL BE INVULNERABLE OR FREE FROM CORRUPTION, ATTACK, VIRUSES, INTERFERENCE, HACKING, DATA LOSS OR THEFT, OR OTHER SECURITY INTRUSION ("Vulnerability Issues"). RENESAS ELECTRONICS DISCLAIMS ANY AND ALL RESPONSIBILITY OR LIABILITY ARISING FROM OR RELATED TO ANY VULNERABILITY ISSUES. FURTHERMORE, TO THE EXTENT PERMITTED BY APPLICABLE LAW, RENESAS ELECTRONICS DISCLAIMS ANY AND ALL WARRANTIES, EXPRESS OR IMPLIED, WITH RESPECT TO THIS DOCUMENT AND ANY RELATED OR ACCOMPANYING SOFTWARE OR HARDWARE, INCLUDING BUT NOT LIMITED TO THE IMPLIED WARRANTIES OF MERCHANTABILITY, OR FITNESS FOR A PARTICULAR PURPOSE.
8. When using Renesas Electronics products, refer to the latest product information (data sheets, user's manuals, application notes, "General Notes for Handling and Using Semiconductor Devices" in the reliability handbook, etc.), and ensure that usage conditions are within the ranges specified by Renesas Electronics with respect to maximum ratings, operating power supply voltage range, heat dissipation characteristics, installation, etc. Renesas Electronics disclaims any and all liability for any malfunctions, failure or accident arising out of the use of Renesas Electronics products outside of such specified ranges.
9. Although Renesas Electronics endeavors to improve the quality and reliability of Renesas Electronics products, semiconductor products have specific characteristics, such as the occurrence of failure at a certain rate and malfunctions under certain use conditions. Unless designated as a high reliability product or a product for harsh environments in a Renesas Electronics data sheet or other Renesas Electronics document, Renesas Electronics products are not subject to radiation resistance design. You are responsible for implementing safety measures to guard against the possibility of bodily injury, injury or damage caused by fire, and/or danger to the public in the event of a failure or malfunction of Renesas Electronics products, such as safety design for hardware and software, including but not limited to redundancy, fire control and malfunction prevention, appropriate treatment for aging degradation or any other appropriate measures. Because the evaluation of microcomputer software alone is very difficult and impractical, you are responsible for evaluating the safety of the final products or systems manufactured by you.
10. Please contact a Renesas Electronics sales office for details as to environmental matters such as the environmental compatibility of each Renesas Electronics product. You are responsible for carefully and sufficiently investigating applicable laws and regulations that regulate the inclusion or use of controlled substances, including without limitation, the EU RoHS Directive, and using Renesas Electronics products in compliance with all these applicable laws and regulations. Renesas Electronics disclaims any and all liability for damages or losses occurring as a result of your noncompliance with applicable laws and regulations.
11. Renesas Electronics products and technologies shall not be used for or incorporated into any products or systems whose manufacture, use, or sale is prohibited under any applicable domestic or foreign laws or regulations. You shall comply with any applicable export control laws and regulations promulgated and administered by the governments of any countries asserting jurisdiction over the parties or transactions.
12. It is the responsibility of the buyer or distributor of Renesas Electronics products, or any other party who distributes, disposes of, or otherwise sells or transfers the product to a third party, to notify such third party in advance of the contents and conditions set forth in this document.
13. This document shall not be reprinted, reproduced or duplicated in any form, in whole or in part, without prior written consent of Renesas Electronics.
14. Please contact a Renesas Electronics sales office if you have any questions regarding the information contained in this document or Renesas Electronics products.

(Note1) "Renesas Electronics" as used in this document means Renesas Electronics Corporation and also includes its directly or indirectly controlled subsidiaries.

(Note2) "Renesas Electronics product(s)" means any product developed or manufactured by or for Renesas Electronics.

(Rev.5.0-1 October 2020)

## Corporate Headquarters

TOYOSU FORESIA, 3-2-24 Toyosu,  
Koto-ku, Tokyo 135-0061, Japan  
[www.renesas.com](http://www.renesas.com)

## Trademarks

Renesas and the Renesas logo are trademarks of Renesas Electronics Corporation. All trademarks and registered trademarks are the property of their respective owners.

## Contact information

For further information on a product, technology, the most up-to-date version of a document, or your nearest sales office, please visit:  
[www.renesas.com/contact/](http://www.renesas.com/contact/).