

RL78/G23

Automatic Liquid Dispenser with Proximity Capacitive Sensing

Introduction

This document describes a Renesas microcontroller RL78/G23 application for automatic liquid dispenser.

Target Device

RL78/G23

When applying the sample program covered in this application note to another microcomputer, modify the program according to the specifications for the target microcomputer and conduct an extensive evaluation of the modified program.

Contents

1. Description	3
1.1 Abstract	3
1.2 Specifications and Main Technical Parameters	3
1.2.1 Technical Parameters	3
1.2.2 Specifications	3
2. RL78/G23 Microcontroller	4
2.1 RL78/G23 Block Diagram	4
2.2 Outline of Functions	5
2.3 Pin Configuration	8
3. System Outline	9
3.1 Principle Introduction	9
3.2 Peripheral Functions to be Used	10
3.3 Pins to be Used	10
3.4 Operations	10
4. Hardware	11
4.1 Power Supply	12
4.2 Electrode Circuit	13
4.3 Buzzer Driver Circuit	13
4.4 LED Driver Circuit	14
4.5 Motor Driver Circuit	14
5. Software	15
5.1 Operation Check Conditions	15
5.2 Option Byte	15
5.3 Operation Outline	16
5.4 Flow Chart	18
5.4.1 Main Processing	18
6. Sample Code	20
7. Reference Documents	20
Revision History	21

1. Description

1.1 Abstract

An automatic liquid dispenser is specifically a hands-free dispenser of liquids such as soap, hand sanitizer, shampoos, or hand lotions. As touch-free design by using proximity sensing technique eliminates bacterial transmission, automatic liquid dispenser is popular in public places and private institutions. Dispenser only distributes a set amount of liquid per motion activation to minimize waste. This document provides an automatic liquid dispenser solution with proximity capacitive sensing based on Renesas microcontroller RL78/G23 with new features of capacitive sensing unit (CTS2L), ultra-low power consumption technology, logic and event link controller (ELCL), output current control pins, etc.

1.2 Specifications and Main Technical Parameters

1.2.1 Technical Parameters

- Power supply: 6 V (4 AAA batteries)
- Low power consumption current: 660 μ A when MCU is in STOP + SNOOZE mode
- Sensing method: Proximity Sensing by Capacitive Sensing Unit (CTS2L)
- Sensing distance: 2.5 to 3.5 cm
- Amount of liquid per motion activation: 0.5 / 0.8 ml selectable

1.2.2 Specifications

- Low power consumption function: When power switch is set to OFF, the power supply of the system is cut off and no current consumption is achieved. After the system is powered on, it operates in low power consumption mode in most conditions to obtain longer battery life.
- Audible and visual indication function: If hands are placed under the nozzle, LED and buzzer are turned on to indicate liquid dispensing.
- Dispensing time limit function: Even if hands are always under the nozzle, a maximum duration of 2 seconds dispensing is accomplished.
- Low battery voltage warning: When battery voltage is lower than 4.8 V in which condition drive capability of battery is too low to operate motors, LED blinks to indicate this low power condition when hands are placed under the nozzle.
- Dispensing amount selectable: Switch is used to select amount of liquid dispensing per motion.
- Operating temperature: -10°C to 60°C
- Operating humidity: 5 to 99% RH (No condensate water)

2. RL78/G23 Microcontroller

2.1 RL78/G23 Block Diagram

Figure 2.1 shows the block diagram of RL78/G23.

This Automatic Liquid Dispenser uses the RL78/G23 32-pin plastic LQFP (7 × 7 mm, 0.80-mm pitch) product.

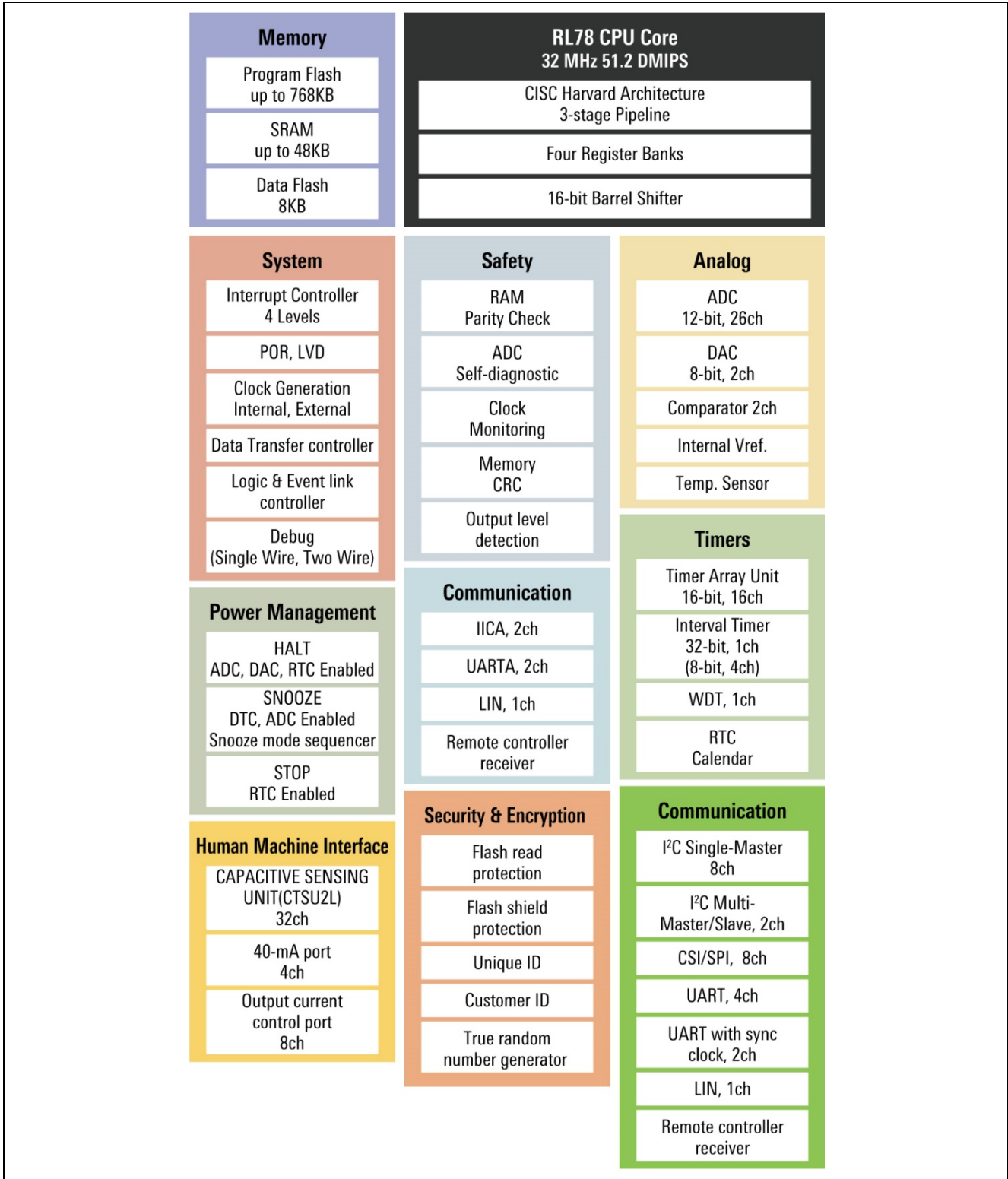

Figure 2.1 RL78/G23 Block Diagram

2.2 Outline of Functions

Caution: This outline describes the functions at the time when peripheral I/O redirection register (PIOR) is set to 00H.

Table 2.1 Outline of Functions (1/3)

Item		32-pin
		R7F100GBG2DFP
Code flash memory		96 to 256 KB
Data flash memory		8 KB
RAM		12 to 24 KB
Address space		1 MB
CPU/peripheral hardware clock frequency (f _{CLK})		Main system clock HS mode: 1 to 32 MHz (V _{DD} = 1.8 to 5.5 V) Main system clock HS mode: 1 to 4 MHz ^{Note 1} (V _{DD} = 1.6 to 5.5 V) Main system clock LS mode: 1 to 24 MHz (V _{DD} = 1.8 to 5.5 V) Main system clock LS mode: 1 to 4 MHz ^{Note 1} (V _{DD} = 1.6 to 5.5 V) Main system clock LP mode: 1 to 2 MHz ^{Note 2} (V _{DD} = 1.6 to 5.5 V) Subsystem clock: 32.768 kHz (V _{DD} = 1.6 to 5.5 V)
Main system clock	High-speed system clock (f _{MX})	1 to 20 MHz
	High-speed on-chip oscillator clock (f _{IH})	1 MHz, 2 MHz, 3 MHz, 4 MHz, 6 MHz, 8 MHz, 12 MHz, 16 MHz, 24 MHz, 32 MHz
	Middle-speed on-chip oscillator clock (f _{IM})	1 MHz, 2 MHz, 4 MHz
Subsystem clock	Subsystem clock X (f _{SX})	32.768 kHz (V _{DD} = 2.4 to 5.5 V)
	Low-speed on-chip oscillator clock (f _L)	32.768 kHz (typ.)
General-purpose registers		8 bits × 32 registers (8 bits × 8 registers × 4 banks)
Minimum instruction execution time		0.03125 μs (at the 32 MHz operation with the high-speed on-chip oscillator clock (f _{IH}))
Instruction set		<ul style="list-style-type: none"> • Data transfer (8/16 bits) • Adder and subtractor/logical operation (8/16 bits) • Multiplication (8 bits × 8 bits, 16 bits × 16 bits), division (16 bits ÷ 16 bits, 32 bits ÷ 32 bits) • Multiplication and accumulation (16 bits × 16 bits + 32 bits) • Rotate, barrel shift, and bit manipulation (set, reset, test, and Boolean operation), etc.
I/O port	Total number of pins	28
	CMOS I/O	24 (N-ch open drain I/O [V _{DD} withstand voltage]: 10)
	CMOS input	1
	CMOS output	—
	N-ch open drain I/O (withstand voltage: 6 V)	3
	Output current control port	7

Table 2.1 Outline of Functions (2/3)

Item		32-pin
		R7F100GBG2DFP
Timers	16-bit timer	8 channels
	Watchdog timer	1 channel
	Realtime clock (RTC)	1 channel
	32-bit interval timer (TML32)	1 channel in 32-bit mode, 2 channels in 16-bit mode, 4 channels in 8-bit mode
	Timer output	4 channels (PWM outputs: 3 ^{Note 3}), 8 channels (PWM outputs: 7 ^{Note 3}) ^{Note 4}
	RTC output	1 channel
Clock output/buzzer output		2 <ul style="list-style-type: none"> 3.91 kHz, 7.81 kHz, 15.63 kHz, 2 MHz, 4 MHz, 8 MHz, 16 MHz (at the 32 MHz operation with the main system clock (f_{MAIN})) 256 Hz, 512 Hz, 1.024 kHz, 2.048 kHz, 4.096 kHz, 8.192 kHz, 16.384 kHz, 32.768 kHz (at the 32.768 kHz operation with the low-speed peripheral clock (fs_{XP}))
8-/10-/12-bit resolution A/D converter		8 channels
D/A converter		2 channels
Comparator		2 channels
Serial interface		<ul style="list-style-type: none"> CSI: 1 channel/simplified I²C: 1 channel/UART: 1 channel CSI: 1 channel/simplified I²C: 1 channel/UART: 1 channel CSI: 1 channel/simplified I²C: 1 channel/UART (UART supporting LIN-bus): 1 channel
	UARTA	—
	I ² C bus	1 channel
Remote control signal receiver		1 channel
Data transfer controller (DTC)		30 sources
Logic and event link controller (ELCL)		1
SNOOZE mode sequencer (SMS)		1
Capacitive sensing unit		7
Vectored interrupt sources	Internal	32
	External	6
Key interrupt		—
Reset		<ul style="list-style-type: none"> Reset by RESET pin Internal reset by watchdog timer Internal reset by power-on-reset Internal reset by voltage detectors (LVD0 and LVD1) Internal reset by illegal instruction execution^{Note 5} Internal reset by RAM parity error Internal reset by illegal-memory access

Table 2.1 Outline of Functions (3/3)

Item	32-pin
	R7F100GBG2DFP
Power-on-reset circuit	<ul style="list-style-type: none"> • Power-on-reset: 1.51 V (typ.) • Power-down-reset: 1.50 V (typ.)
Voltage detector	<ul style="list-style-type: none"> • Rising edge: 1.67 to 4.00 V (6 stages) for LVD0 1.67 to 4.16 V (18 stages) for LVD1 • Falling edge: 1.63 to 3.92 V (6 stages) for LVD0 1.63 to 4.08 V (18 stages) for LVD1
On-chip debugging	Available (tracing supported)
Power supply voltage	V _{DD} = 1.6 to 5.5 V (2D: Consumer applications), V _{DD} = 1.8 to 5.5 V (3C: Industrial applications)
Operating ambient temperature	T _A = -40 to +85°C (2D: Consumer applications), T _A = -40 to +105°C (3C: Industrial applications)

- Note 1.** Overwrite the flash memory during operation at 2 MHz or a lower frequency.
- Note 2.** When the flash memory is to be overwritten, switch to high-speed main (HS) mode or low-speed main (LS) mode.
- Note 3.** The number of PWM outputs varies depending on the setting of channels in use (the number of masters and slaves).
- Note 4.** This applies when the setting of the PIOR0 bit is 1.
- Note 5.** In normal operation, executing the instruction code FFH triggers an internal reset, but this is not the case during emulation by the in-circuit emulator or on-chip debugging emulator.

2.3 Pin Configuration

Figure 2.2 shows the pin configuration of RL78/G23 32-pin plastic LQFP (7 × 7 mm, 0.80-mm pitch) product.

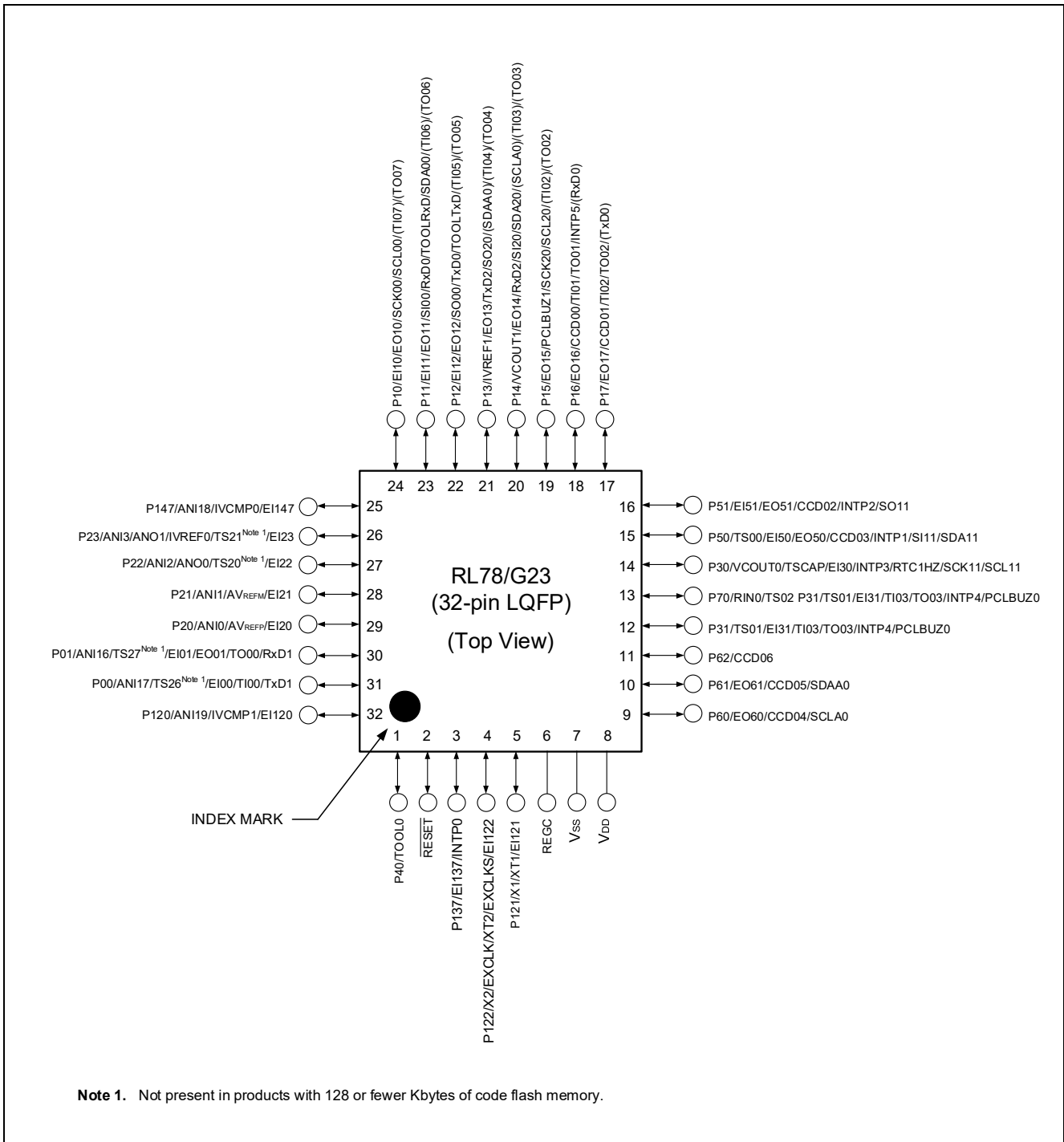

Figure 2.2 RL78/G23 Pin Configuration (32-pin Plastic LQFP Product)

3. System Outline

3.1 Principle Introduction

The automatic liquid dispenser with proximity capacitive sensing utilizes the RL78/G23's new features of capacitive sensing unit (CTSU2L), Ultra-low power consumption technology, logic and event link controller (ELCL), output current control pins, etc.

After system initialization is completed, STOP mode is entered for low power consumption. Every 100 milliseconds MCU is waked up from STOP mode, and then has a transition from STOP mode to SNOOZE mode after detecting the interrupt of the 32-bit Interval Timer which is linked capacitive sensing unit (CTSU2L) by the logic and event link controller (ELCL). Because CTSU2L supports SNOOZE function, it can implement the measurement of the electrostatic capacitance of the capacitive electrode in the SNOOZE mode. After the completion of CTSU2L's measurement, MCU has a transition from SNOOZE mode to normal operation, and then implements the Hands IN/OUT detection in normal status of MCU.

Thus, if the finger is close to the capacitive electrode, MCU detects the change of electrostatic capacitance of the capacitive electrode and activates the LED, the buzzer and the motor. Liquid is pumped through the nozzle by the motor.

The control of the LED uses the output current control pins. It controls low-level output current (2/5/10/15mA) and it enables operation of LED drives without limiting resistance.

OFF-NORMAL-LIGHT switch is used to switch between the power-off, normal mode and light mode. In normal mode, 0.8 ml of liquid is distributed per motion activation and in the light mode, 0.5 ml of liquid is distributed per motion activation.

Figure 3.1 shows the system block diagram for this document.

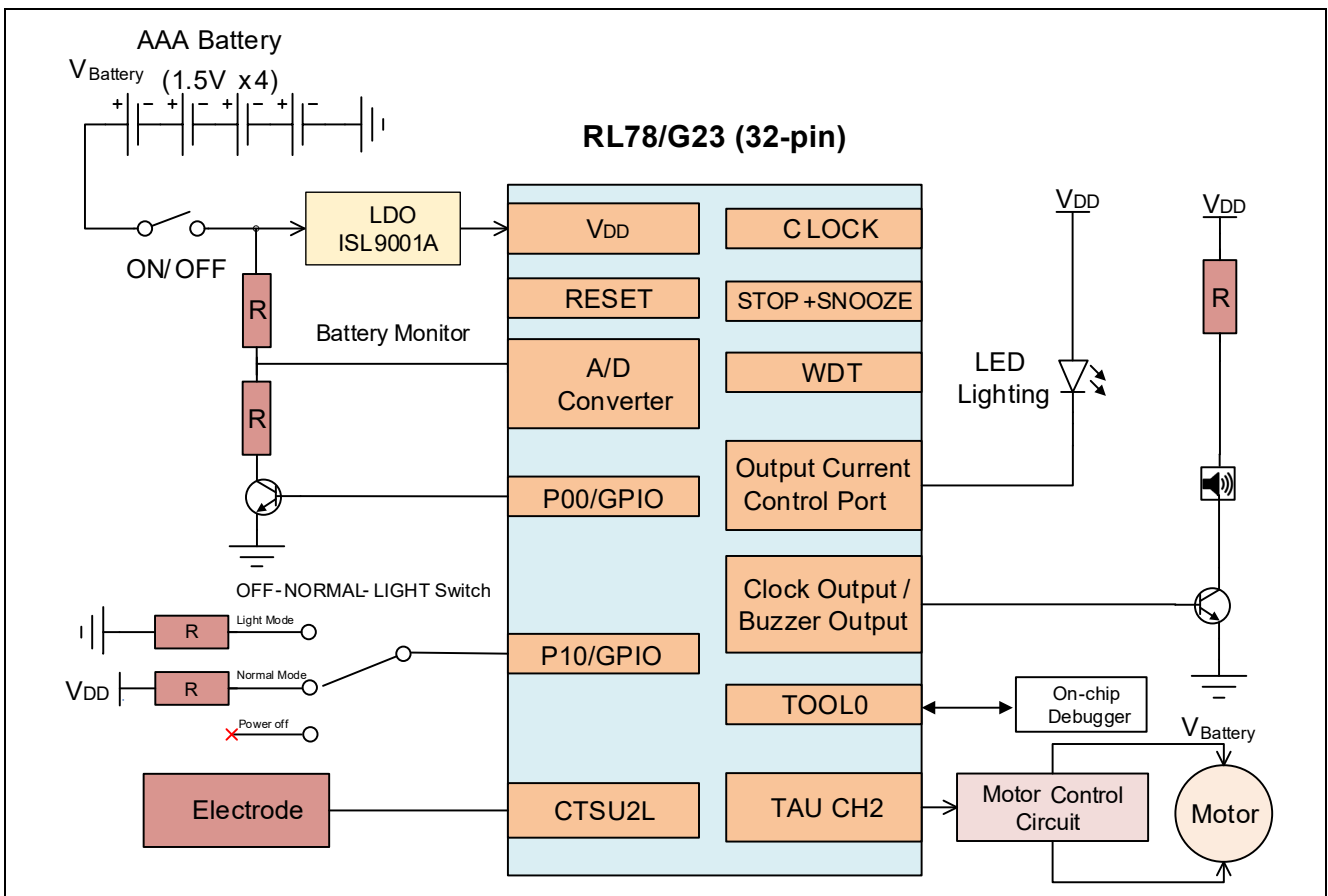

Figure 3.1 System Block Diagram

3.2 Peripheral Functions to be Used

Table 3.1 lists the peripheral functions to be used and their usages.

Table 3.1 Peripheral Functions to be Used

Peripheral Function	Usage
32-bit Interval Timer	Generate 100 milliseconds interval to wake up MCU from STOP mode
ELCL	Link the 32-bit Interval Timer and CTSU2L
CTSU2L	Detect the capacitance change
PCLBUZ1	Output a square wave to drive the buzzer
A/D Converter	Monitor the battery voltage
I/O port	Detect the mode select of dispensing liquid
Output current control port	Drive the LED
Timer Array Unit	Output PWM to drive the motor LED

3.3 Pins to be Used

Table 3.2 lists the pins to be used and their descriptions.

Table 3.2 Pins to be Used

Pin Name	Description
P40/TOOL0	On-chip debug
P125/RESET	Hardware reset
P10/GPIO	OFF-NORMAL-LIGHT switch Normal/Light mode selection of dispensing liquid
V _{SS}	Ground
V _{DD}	Power supply voltage
P20/ANI00	Battery voltage
P31/TS01	Capacitive Electrode
P00/GPIO	Enable the input of half battery voltage to A/D converter
P15/PCLBUZ1	Drive speaker
P17/TO02	Drive motor
P60/CCD04	Drive LED

3.4 Operations

- (1) After OFF-NORMAL-LIGHT switch is selected to NORMAL, the system is powered on and normal mode is selected in which 0.8 ml of liquid is distributed per motion activation. If hands are placed in proximity to the electrode, motor is activated to pump liquid from tank. LED and buzzer are turned on to indicate liquid dispensing. As soon as hands are removed, dispensing is terminated.
- (2) When OFF-NORMAL-LIGHT switch is selected to LIGHT, light mode is selected in which 0.5 ml of liquid is distributed per motion activation. All the other operations are the same as that in normal mode.
- (3) Even if hands are kept placed under the nozzle without any leave, the system dispenses liquid for a maximum time of 2 seconds.
- (4) Each time hands are placed under the nozzle; battery voltage is checked and low-voltage warning is indicated through buzzer alarming if battery is in low power status.

4. Hardware

There is a capacitive electrode, buzzer, LED and motor in the system. When hands are close to the electrode, the electrostatic capacitance is changed. MCU detects that change and drives buzzer, LED and motor. Liquid is pumped through the nozzle with motor running.

Figure 4.1 shows the demo appearance. Figure 4.2 shows the details of the demo board.

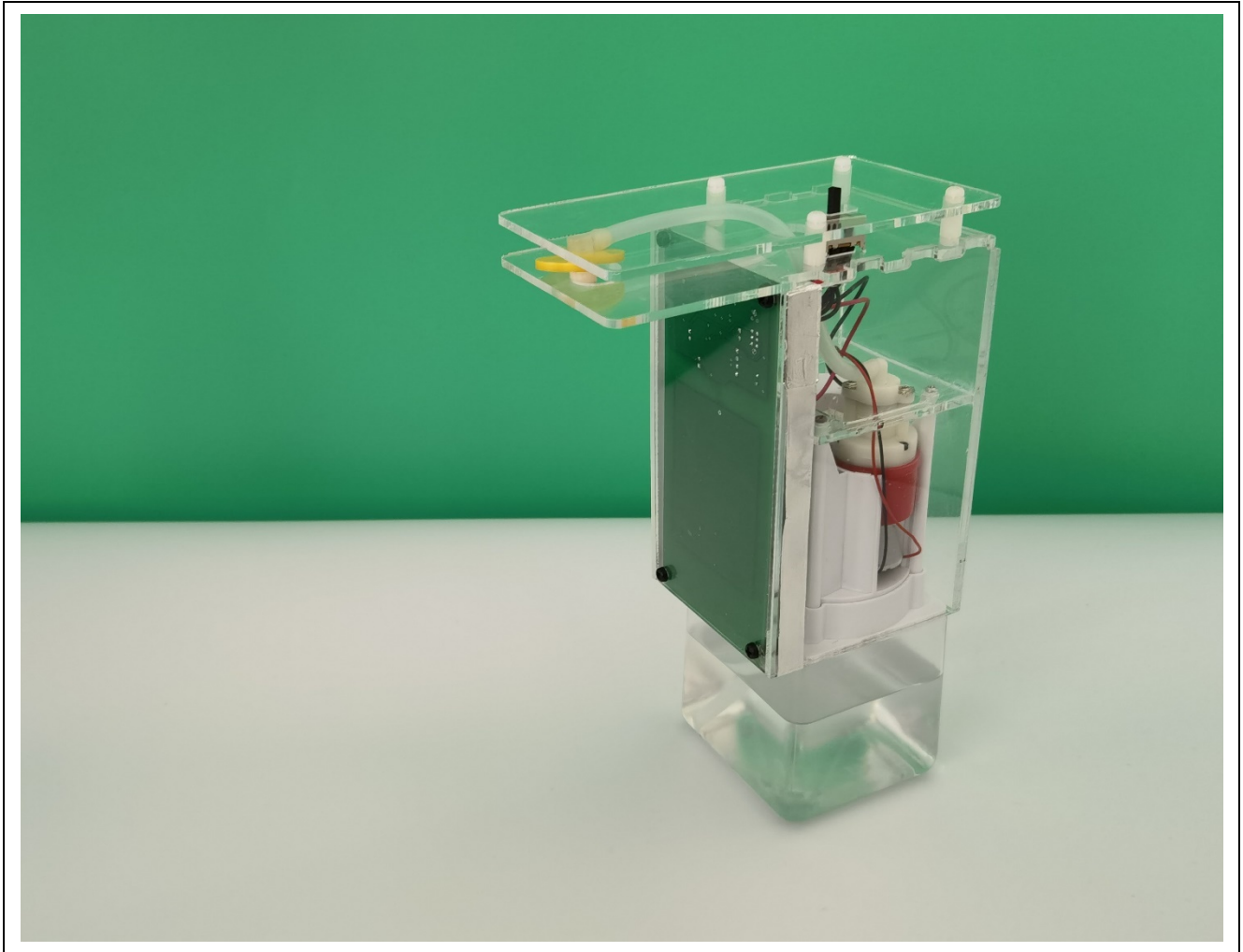

Figure 4.1 Demo Appearance

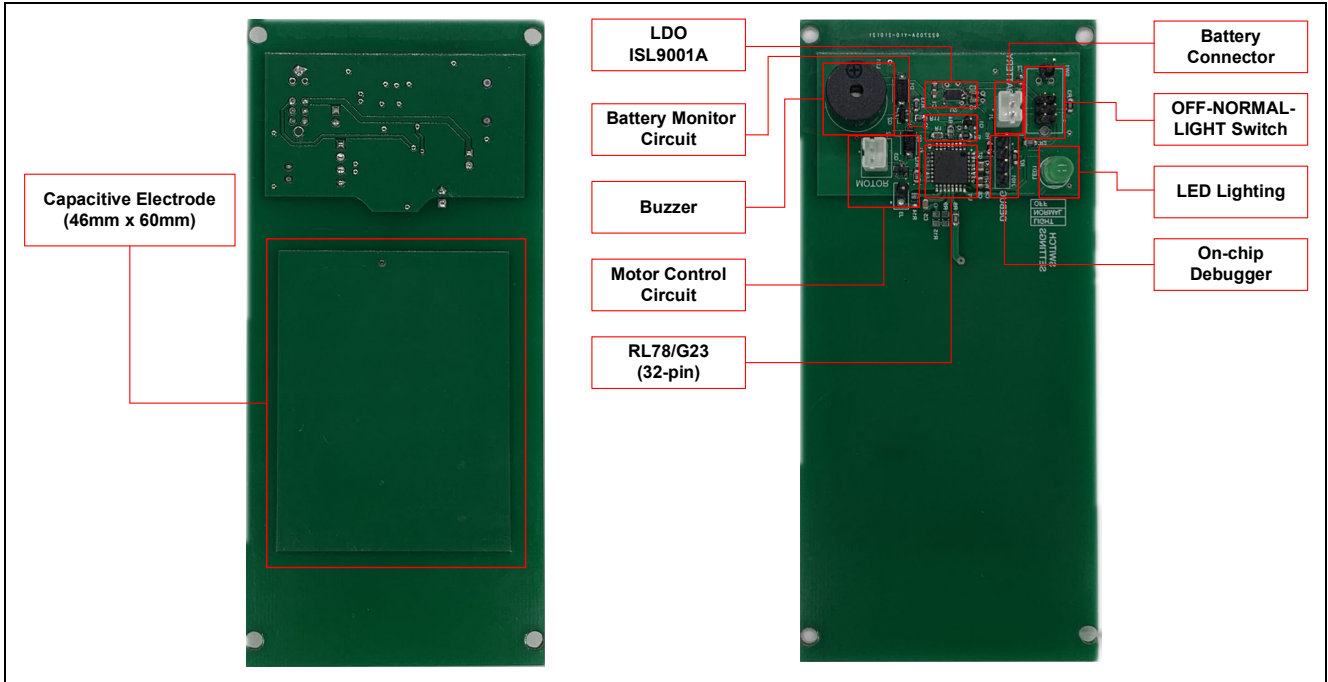

Figure 4.2 Demo Board (Top layer and Bottom layer)

4.1 Power Supply

Figure 4.3 shows the schematic of power supply.

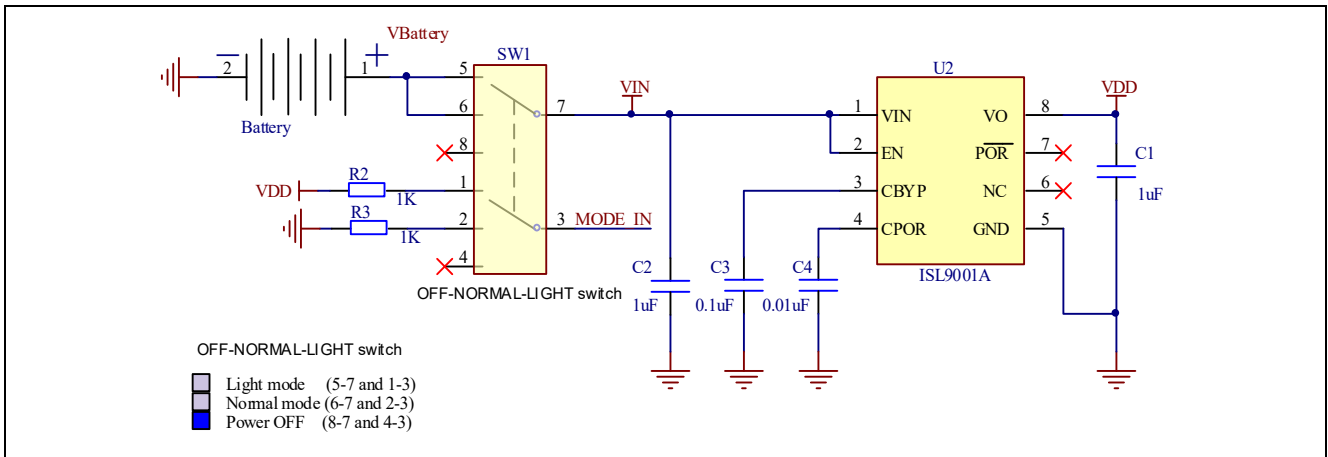

Figure 4.3 Power Supply

ISL9001AIRNZ-T is a high-performance Low Dropout linear regulator capable of sourcing 300 mA current which is larger than the system current consumption.

3.3 V fixed output of ISL9001AIRNZ-T supplies power for MCU, Motor, LED and buzzer.

Extremely low quiescent current of 25 μ A makes the battery life longer.

4.2 Electrode Circuit

Figure 4.4 shows the schematics of the electrode circuit.

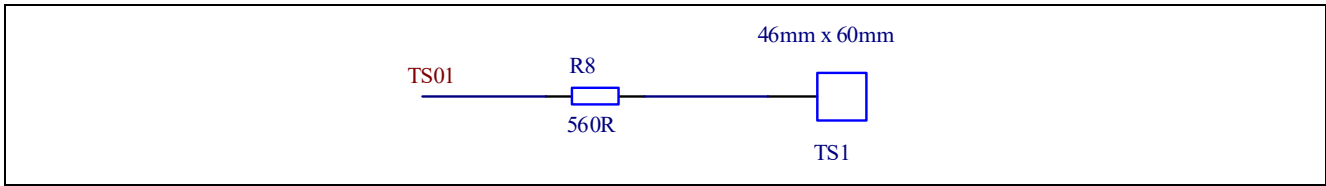

Figure 4.4 the Electrode Circuit

4.3 Buzzer Driver Circuit

Figure 4.5 shows the schematic of the buzzer driver circuit.

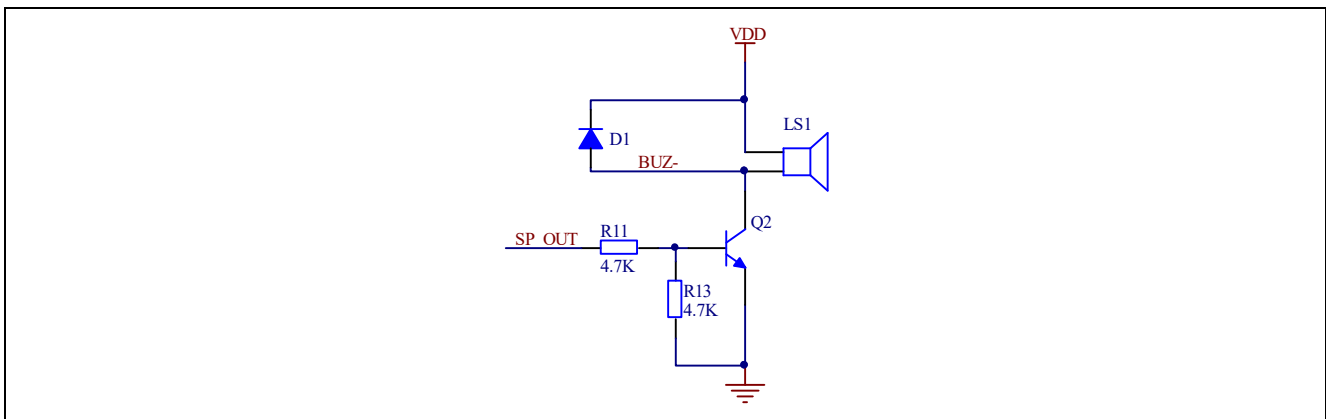

Figure 4.5 Buzzer Driver Circuit

The buzzer with 2300±500 Hz resonant frequency, 25 mA rated current and 3.5 V to 5.5 V rated voltage is used in the system to indicate liquid dispensing and battery low-voltage warning.

MCU outputs square wave of 2.048 kHz with PCLBUZ1 to SP_OUT to make the buzzer sound when hands are placed under the nozzle.

If the system detects the voltage of the battery is lower than 4.8 V, output of PCLBUZ1 is toggled between on and off every 100 milliseconds to indicate battery low-voltage.

4.4 LED Driver Circuit

Figure 4.6 shows the schematic of the LED driver circuit.

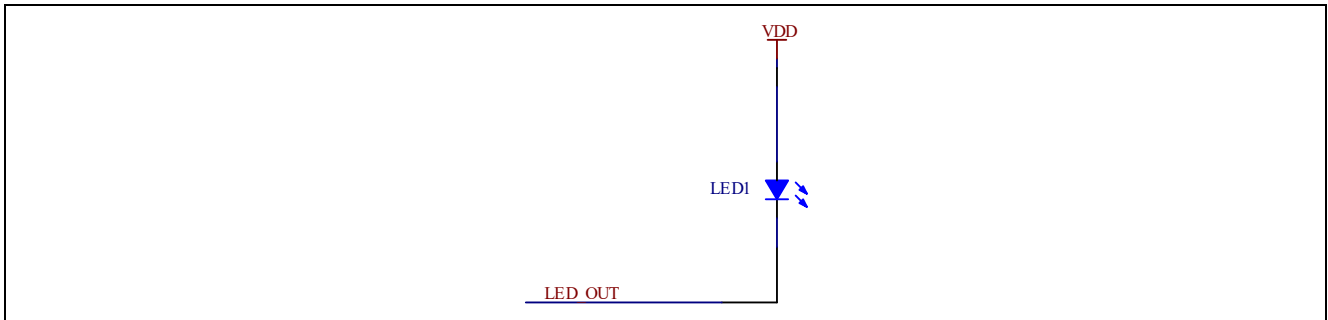

Figure 4.6 LED Driver Circuit

A basic yellow 3mm LED with 2.0 to 2.4 V forward drop, 20 mA maximum current and 40 to 100 mcd luminous intensity is used to indicate liquid dispensing in the system.

MCU drives the LED with output current control pin (P60 with 20mA).

4.5 Motor Driver Circuit

Figure 4.7 shows the schematic of the motor driver circuit.

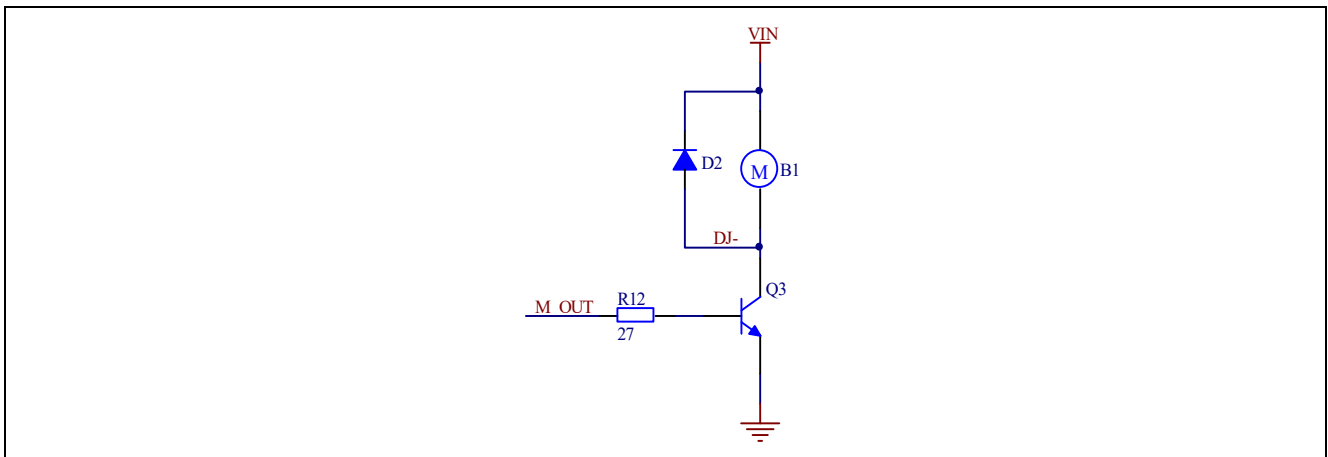

Figure 4.7 Motor Driver Circuit

DC motor of 5 V rated voltage, 0.49 mN·m rated load and 11600 min⁻¹ is used in this system to drive the fan to pump liquid from tank.

MCU drives the motor with PWM of Timer Array Unit to M_OUT.

PWM with a duty cycle of 100% is used to drive motor for liquid pumping in NORMAL mode while 75% in LIGHT mode.

5. Software

5.1 Operation Check Conditions

The sample code described in this chapter has been checked under the conditions listed in the table below.

Table 5.1 Operation Check Conditions

Item	Description
Microcontroller used	RL78/G23 (R7F100GBG2DFP)
Operating frequency	High-speed on-chip oscillator clock: 32 MHz CPU/peripheral hardware clock: 32 MHz
Operating voltage	3.3 V (can run on a voltage range of 2.7 V to 5.5 V.) LVD0 Detection Voltage: Reset mode When power supply falls: TYP. 2.62V (2.54 V to 2.70 V) When power supply rises: TYP. 2.67V (2.59 V to 2.75 V)
C compiler (e ² studio)	CC-RL V1.09.00 from Renesas Electronics Corporation.
Integrated development environment (e ² studio)	e2 studio 2021-01 from Renesas Electronics Corporation. CTSU2L Driver v0.90 QE for Capacitive Touch [RA, RL78] V1.3 alpha3

5.2 Option Byte

Table 5.2 summarizes the settings of the option bytes.

Table 5.2 Option Byte Settings

Address	Value	Description
000C0H/010C0H	11101111B	Watchdog timer counter operation disabled (counting stopped after reset)
000C1H/010C1H	11111100B	LVD0 ON
000C2H/010C2H	10101101B	Operating frequency: 1 MHz (1.8 V to 5.5 V)
000C3H/010C3H	00000100B	Disables on-chip debug operation

5.3 Operation Outline

The tasks of the entire system are listed as below: reset/initialization, STOP + SNOOZE mode, normal dispensing, light dispensing and battery low voltage warning.

Figure 5.1 shows the block diagram for the tasks transition.

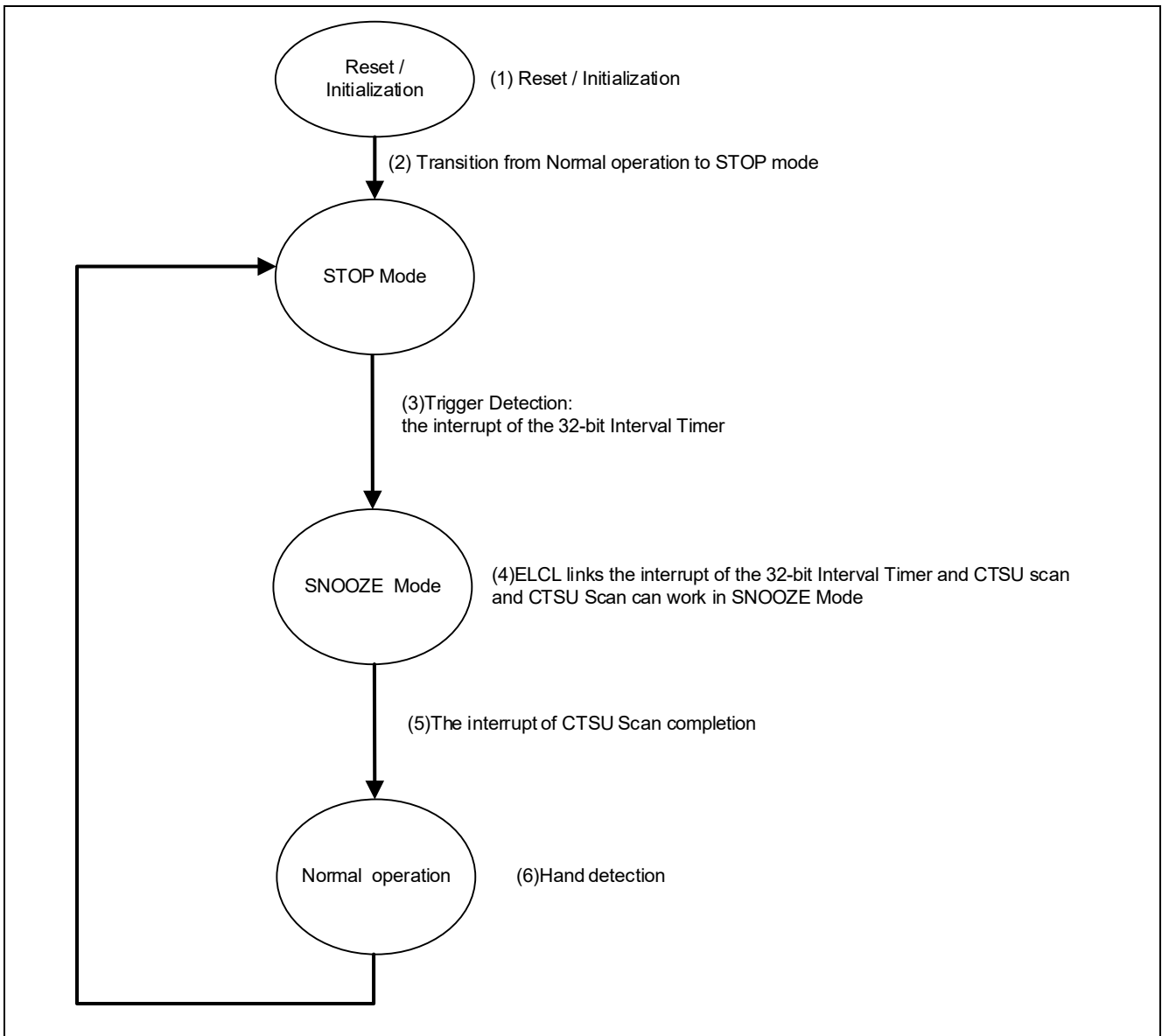

Figure 5.1 Tasks Transition Block Diagram

(1) Reset / Initialization

After OFF-Light-Normal is activated, the system is powered on and initialization routine of each module is executed. The 32-bit Interval Timer starts with 100 milliseconds' interval.

(2) Transition from Normal operation to STOP mode

After system initialization is completed, MCU will transit from Normal operation to STOP mode.

(3) Transition from STOP mode to SNOOZE mode

MCU will transit from STOP mode to SNOOZE mode after trigger detection. Here, the trigger is the interrupt of the 32-bit Interval Timer.

(4) CTSU Scan in the SNOOZE mode

After detecting the interrupt of the 32-bit Interval Timer which is linked capacitive sensing unit (CTS2L) by the logic and event link controller (ELCL), because CTS2L supports SNOOZE function, it can implement the measurement of the electrostatic capacitance of the capacitive electrode in the SNOOZE mode.

(5) Transition from STOP mode to Normal operation

After the completion of CTSU Scan, MCU will transit from STOP mode to Normal operation.

(6) Hand detection

When battery voltage is lower than 4.8 V, each time hands are detected, buzzer is alarmed while LED and motor are kept not working.

In the normal operation, if OFF-Normal-Light switch is in Light position, when hands are detected, motor is driven to pump liquid from tank that 0.5 ml of liquid is distributed per motion activation, LED and buzzer are activated to indicate liquid dispensing.

if OFF-Normal-Light switch is in Normal position, when hands are detected, motor is driven to pump liquid from tank that 0.8 ml of liquid is distributed per motion activation. LED and buzzer are activated to indicate liquid dispensing.

If hands OUT is detected or hands IN lasts for over 2 seconds, MCU will transit from Normal operation to STOP mode.

5.4 Flow Chart

5.4.1 Main Processing

Figure 5.2 and Figure 5.3 show the flowchart for main processing routine.

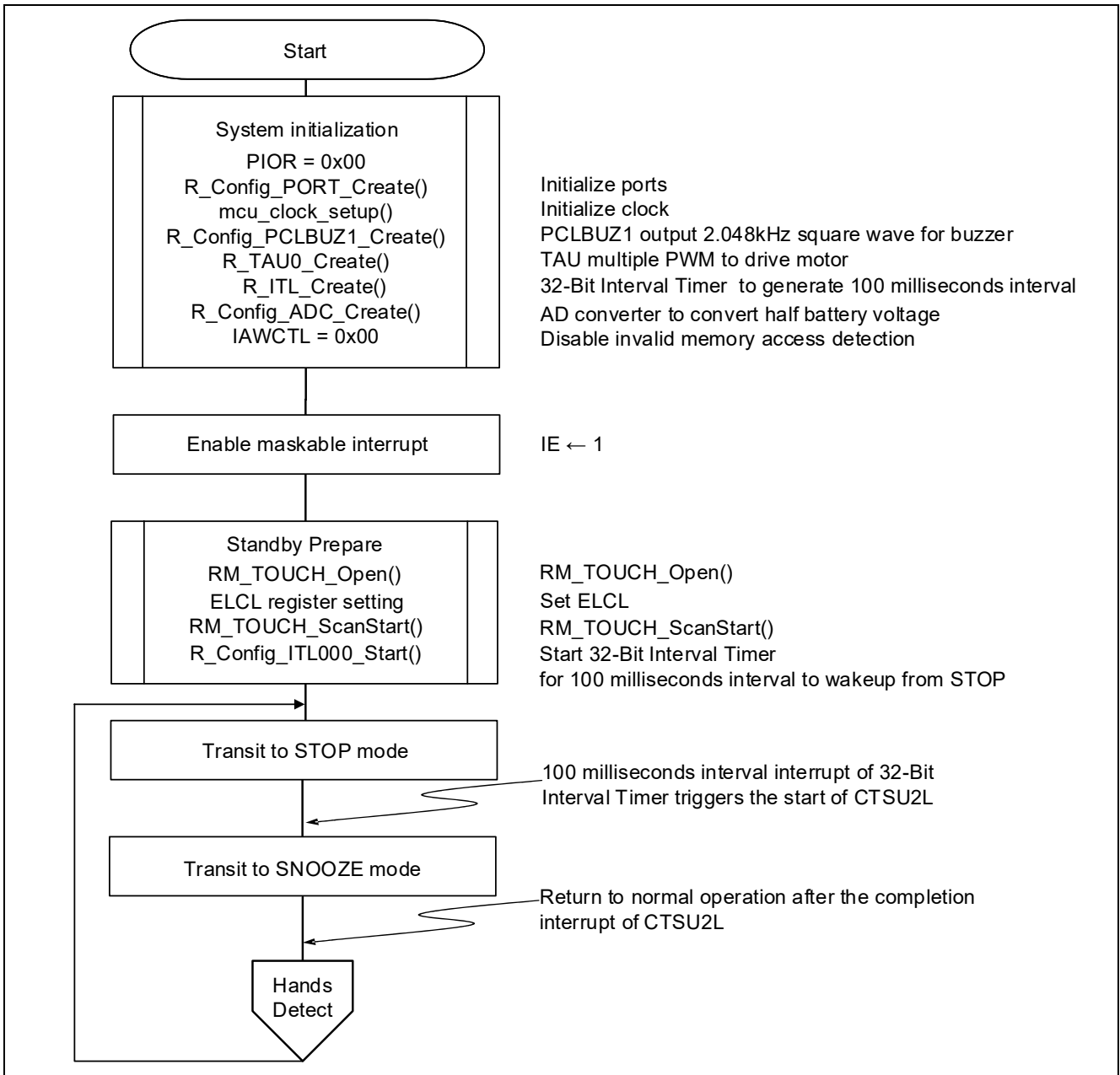

Figure 5.2 Main Processing (1/2)

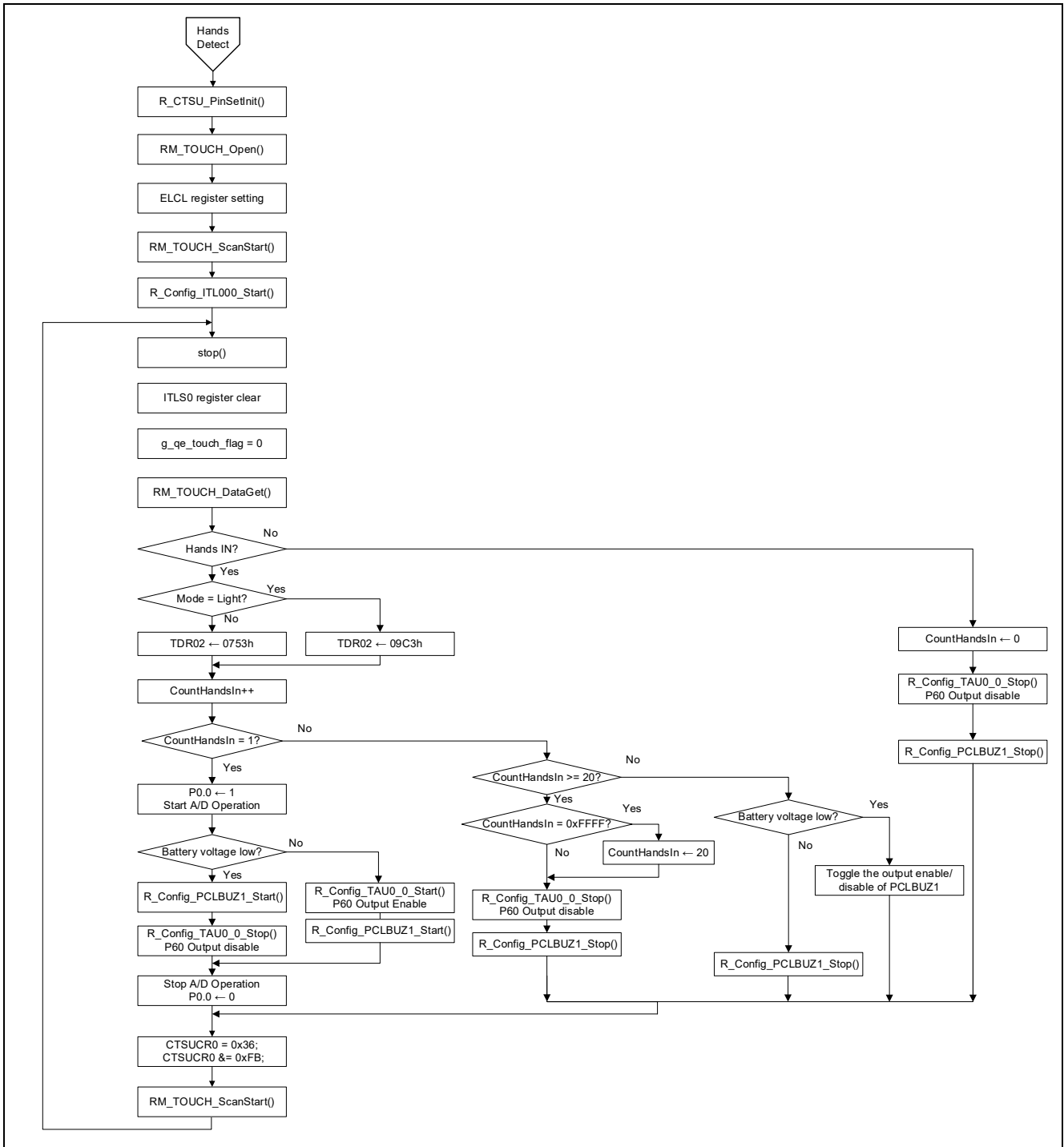

Figure 5.3 Main Processing (2/2)

6. Sample Code

The sample code is available on the Renesas Electronics Website.

7. Reference Documents

RL78/G23 User's Manual: Hardware (R01UH0896)

RL78 Family User's Manual: Software (R01US0015)

RL78 Family Capacitive Sensing Unit (CTSU2L) Operation Explanation(R01AN5744)

(The latest versions of the documents are available on the Renesas Electronics Website.)

Technical Updates/Technical News

(The latest information can be downloaded from the Renesas Electronics Website.)

Revision History

Rev.	Date	Description	
		Page	Summary
1.00	Mar. 31, 21	-	First edition issued

General Precautions in the Handling of Microprocessing Unit and Microcontroller Unit Products

The following usage notes are applicable to all Microprocessing unit and Microcontroller unit products from Renesas. For detailed usage notes on the products covered by this document, refer to the relevant sections of the document as well as any technical updates that have been issued for the products.

1. Precaution against Electrostatic Discharge (ESD)

A strong electrical field, when exposed to a CMOS device, can cause destruction of the gate oxide and ultimately degrade the device operation. Steps must be taken to stop the generation of static electricity as much as possible, and quickly dissipate it when it occurs. Environmental control must be adequate. When it is dry, a humidifier should be used. This is recommended to avoid using insulators that can easily build up static electricity.

Semiconductor devices must be stored and transported in an anti-static container, static shielding bag or conductive material. All test and measurement tools including work benches and floors must be grounded. The operator must also be grounded using a wrist strap. Semiconductor devices must not be touched with bare hands. Similar precautions must be taken for printed circuit boards with mounted semiconductor devices.

2. Processing at power-on

The state of the product is undefined at the time when power is supplied. The states of internal circuits in the LSI are indeterminate and the states of register settings and pins are undefined at the time when power is supplied. In a finished product where the reset signal is applied to the external reset pin, the states of pins are not guaranteed from the time when power is supplied until the reset process is completed. In a similar way, the states of pins in a product that is reset by an on-chip power-on reset function are not guaranteed from the time when power is supplied until the power reaches the level at which resetting is specified.

3. Input of signal during power-off state

Do not input signals or an I/O pull-up power supply while the device is powered off. The current injection that results from input of such a signal or I/O pull-up power supply may cause malfunction and the abnormal current that passes in the device at this time may cause degradation of internal elements. Follow the guideline for input signal during power-off state as described in your product documentation.

4. Handling of unused pins

Handle unused pins in accordance with the directions given under handling of unused pins in the manual. The input pins of CMOS products are generally in the high-impedance state. In operation with an unused pin in the open-circuit state, extra electromagnetic noise is induced in the vicinity of the LSI, an associated shoot-through current flows internally, and malfunctions occur due to the false recognition of the pin state as an input signal become possible.

5. Clock signals

After applying a reset, only release the reset line after the operating clock signal becomes stable. When switching the clock signal during program execution, wait until the target clock signal is stabilized. When the clock signal is generated with an external resonator or from an external oscillator during a reset, ensure that the reset line is only released after full stabilization of the clock signal. Additionally, when switching to a clock signal produced with an external resonator or by an external oscillator while program execution is in progress, wait until the target clock signal is stable.

6. Voltage application waveform at input pin

Waveform distortion due to input noise or a reflected wave may cause malfunction. If the input of the CMOS device stays in the area between V_{IL} (Max.) and V_{IH} (Min.) due to noise, for example, the device may malfunction. Take care to prevent chattering noise from entering the device when the input level is fixed, and also in the transition period when the input level passes through the area between V_{IL} (Max.) and V_{IH} (Min.).

7. Prohibition of access to reserved addresses

Access to reserved addresses is prohibited. The reserved addresses are provided for possible future expansion of functions. Do not access these addresses as the correct operation of the LSI is not guaranteed.

8. Differences between products

Before changing from one product to another, for example to a product with a different part number, confirm that the change will not lead to problems. The characteristics of a microprocessing unit or microcontroller unit products in the same group but having a different part number might differ in terms of internal memory capacity, layout pattern, and other factors, which can affect the ranges of electrical characteristics, such as characteristic values, operating margins, immunity to noise, and amount of radiated noise. When changing to a product with a different part number, implement a system-evaluation test for the given product.

Notice

1. Descriptions of circuits, software and other related information in this document are provided only to illustrate the operation of semiconductor products and application examples. You are fully responsible for the incorporation or any other use of the circuits, software, and information in the design of your product or system. Renesas Electronics disclaims any and all liability for any losses and damages incurred by you or third parties arising from the use of these circuits, software, or information.
2. Renesas Electronics hereby expressly disclaims any warranties against and liability for infringement or any other claims involving patents, copyrights, or other intellectual property rights of third parties, by or arising from the use of Renesas Electronics products or technical information described in this document, including but not limited to, the product data, drawings, charts, programs, algorithms, and application examples.
3. No license, express, implied or otherwise, is granted hereby under any patents, copyrights or other intellectual property rights of Renesas Electronics or others.
4. You shall be responsible for determining what licenses are required from any third parties, and obtaining such licenses for the lawful import, export, manufacture, sales, utilization, distribution or other disposal of any products incorporating Renesas Electronics products, if required.
5. You shall not alter, modify, copy, or reverse engineer any Renesas Electronics product, whether in whole or in part. Renesas Electronics disclaims any and all liability for any losses or damages incurred by you or third parties arising from such alteration, modification, copying or reverse engineering.
6. Renesas Electronics products are classified according to the following two quality grades: "Standard" and "High Quality". The intended applications for each Renesas Electronics product depends on the product's quality grade, as indicated below.
 - "Standard": Computers; office equipment; communications equipment; test and measurement equipment; audio and visual equipment; home electronic appliances; machine tools; personal electronic equipment; industrial robots; etc.
 - "High Quality": Transportation equipment (automobiles, trains, ships, etc.); traffic control (traffic lights); large-scale communication equipment; key financial terminal systems; safety control equipment; etc.

Unless expressly designated as a high reliability product or a product for harsh environments in a Renesas Electronics data sheet or other Renesas Electronics document, Renesas Electronics products are not intended or authorized for use in products or systems that may pose a direct threat to human life or bodily injury (artificial life support devices or systems; surgical implantations; etc.), or may cause serious property damage (space system; undersea repeaters; nuclear power control systems; aircraft control systems; key plant systems; military equipment; etc.). Renesas Electronics disclaims any and all liability for any damages or losses incurred by you or any third parties arising from the use of any Renesas Electronics product that is inconsistent with any Renesas Electronics data sheet, user's manual or other Renesas Electronics document.
7. No semiconductor product is absolutely secure. Notwithstanding any security measures or features that may be implemented in Renesas Electronics hardware or software products, Renesas Electronics shall have absolutely no liability arising out of any vulnerability or security breach, including but not limited to any unauthorized access to or use of a Renesas Electronics product or a system that uses a Renesas Electronics product. RENESAS ELECTRONICS DOES NOT WARRANT OR GUARANTEE THAT RENESAS ELECTRONICS PRODUCTS, OR ANY SYSTEMS CREATED USING RENESAS ELECTRONICS PRODUCTS WILL BE INVULNERABLE OR FREE FROM CORRUPTION, ATTACK, VIRUSES, INTERFERENCE, HACKING, DATA LOSS OR THEFT, OR OTHER SECURITY INTRUSION ("Vulnerability Issues"). RENESAS ELECTRONICS DISCLAIMS ANY AND ALL RESPONSIBILITY OR LIABILITY ARISING FROM OR RELATED TO ANY VULNERABILITY ISSUES. FURTHERMORE, TO THE EXTENT PERMITTED BY APPLICABLE LAW, RENESAS ELECTRONICS DISCLAIMS ANY AND ALL WARRANTIES, EXPRESS OR IMPLIED, WITH RESPECT TO THIS DOCUMENT AND ANY RELATED OR ACCOMPANYING SOFTWARE OR HARDWARE, INCLUDING BUT NOT LIMITED TO THE IMPLIED WARRANTIES OF MERCHANTABILITY, OR FITNESS FOR A PARTICULAR PURPOSE.
8. When using Renesas Electronics products, refer to the latest product information (data sheets, user's manuals, application notes, "General Notes for Handling and Using Semiconductor Devices" in the reliability handbook, etc.), and ensure that usage conditions are within the ranges specified by Renesas Electronics with respect to maximum ratings, operating power supply voltage range, heat dissipation characteristics, installation, etc. Renesas Electronics disclaims any and all liability for any malfunctions, failure or accident arising out of the use of Renesas Electronics products outside of such specified ranges.
9. Although Renesas Electronics endeavors to improve the quality and reliability of Renesas Electronics products, semiconductor products have specific characteristics, such as the occurrence of failure at a certain rate and malfunctions under certain use conditions. Unless designated as a high reliability product or a product for harsh environments in a Renesas Electronics data sheet or other Renesas Electronics document, Renesas Electronics products are not subject to radiation resistance design. You are responsible for implementing safety measures to guard against the possibility of bodily injury, injury or damage caused by fire, and/or danger to the public in the event of a failure or malfunction of Renesas Electronics products, such as safety design for hardware and software, including but not limited to redundancy, fire control and malfunction prevention, appropriate treatment for aging degradation or any other appropriate measures. Because the evaluation of microcomputer software alone is very difficult and impractical, you are responsible for evaluating the safety of the final products or systems manufactured by you.
10. Please contact a Renesas Electronics sales office for details as to environmental matters such as the environmental compatibility of each Renesas Electronics product. You are responsible for carefully and sufficiently investigating applicable laws and regulations that regulate the inclusion or use of controlled substances, including without limitation, the EU RoHS Directive, and using Renesas Electronics products in compliance with all these applicable laws and regulations. Renesas Electronics disclaims any and all liability for damages or losses occurring as a result of your noncompliance with applicable laws and regulations.
11. Renesas Electronics products and technologies shall not be used for or incorporated into any products or systems whose manufacture, use, or sale is prohibited under any applicable domestic or foreign laws or regulations. You shall comply with any applicable export control laws and regulations promulgated and administered by the governments of any countries asserting jurisdiction over the parties or transactions.
12. It is the responsibility of the buyer or distributor of Renesas Electronics products, or any other party who distributes, disposes of, or otherwise sells or transfers the product to a third party, to notify such third party in advance of the contents and conditions set forth in this document.
13. This document shall not be reprinted, reproduced or duplicated in any form, in whole or in part, without prior written consent of Renesas Electronics.
14. Please contact a Renesas Electronics sales office if you have any questions regarding the information contained in this document or Renesas Electronics products.

(Note1) "Renesas Electronics" as used in this document means Renesas Electronics Corporation and also includes its directly or indirectly controlled subsidiaries.

(Note2) "Renesas Electronics product(s)" means any product developed or manufactured by or for Renesas Electronics.

(Rev.5.0-1 October 2020)

Corporate Headquarters

TOYOSU FORESIA, 3-2-24 Toyosu,
Koto-ku, Tokyo 135-0061, Japan
www.renesas.com

Trademarks

Renesas and the Renesas logo are trademarks of Renesas Electronics Corporation. All trademarks and registered trademarks are the property of their respective owners.

Contact information

For further information on a product, technology, the most up-to-date version of a document, or your nearest sales office, please visit:
www.renesas.com/contact/.