

Application Note

DA9217/DA9220/DA9121/DA9122 - Adjusting VOUT above 1.9 V

AN-PM-140

Abstract

The application note illustrates using external resistors and capacitors to realize output voltage higher than 1.9V for DA9217/DA9220/DA9121/DA9122.

**DA9217/DA9220/DA9121/DA9122 - Adjusting
V_{OUT} above 1.9 V**

Contents

Abstract	1
1 Terms and Definitions	3
2 References	3
3 Introduction	4
4 Output voltage realization	6
4.1 Waveform Results	7
5 Conclusions	8
Revision History	9

Figures

Figure 1: DA9217/DA9121 Recommended Components and Connections	4
Figure 2: DA9220/DA9122 Recommended Components and Connections	5
Figure 3: Resistive Divider Diagram	6
Figure 4: Register of Buck Output Setting	7
Figure 5: V _{IN} = 3.7 V, V _{OUT} = 2 V, I _{OUT} = 3 A, C _{FF} = 2.2 nF	7
Figure 6: V _{IN} = 5 V, V _{OUT} 3.3 V, I _{OUT} = 3 A, C _{FF} = 2.2 nF	7

DA9217/DA9220/DA9121/DA9122 - Adjusting VOUT above 1.9 V

1 Terms and Definitions

MOSFET	Metal oxide semiconductor field effect transistor
IC	Integrated circuit
PCB	Printed circuit board

2 References

- [1] DA9217, Datasheet, Dialog Semiconductor.
- [2] DA9220, Datasheet, Dialog Semiconductor
- [3] DA9121, Datasheet, Dialog Semiconductor
- [4] DA9122, Datasheet, Dialog Semiconductor

DA9217/DA9220/DA9121/DA9122 - Adjusting VOUT above 1.9 V

3 Introduction

Dialog Semiconductor's DA9217/DA9220 and DA9121/DA9122 are power management ICs with integrated Power MOSFETs, see [1] [2] [3] [4]. DA9217/DA9220 operates as a single-channel, dual-phase buck converter. DA9121/DA9122 operates as a dual-channel, single-phase buck converter. The 2.5 V to 5.5 V input voltage range is suitable for a wide variety of low voltage systems. The output voltage is configurable in the range from 0.3 V to 1.9 V. The recommended components and connections for DA9217/DA9121 are shown in Figure 1. DA9220/DA9122's recommended components and connections are shown in Figure 2.

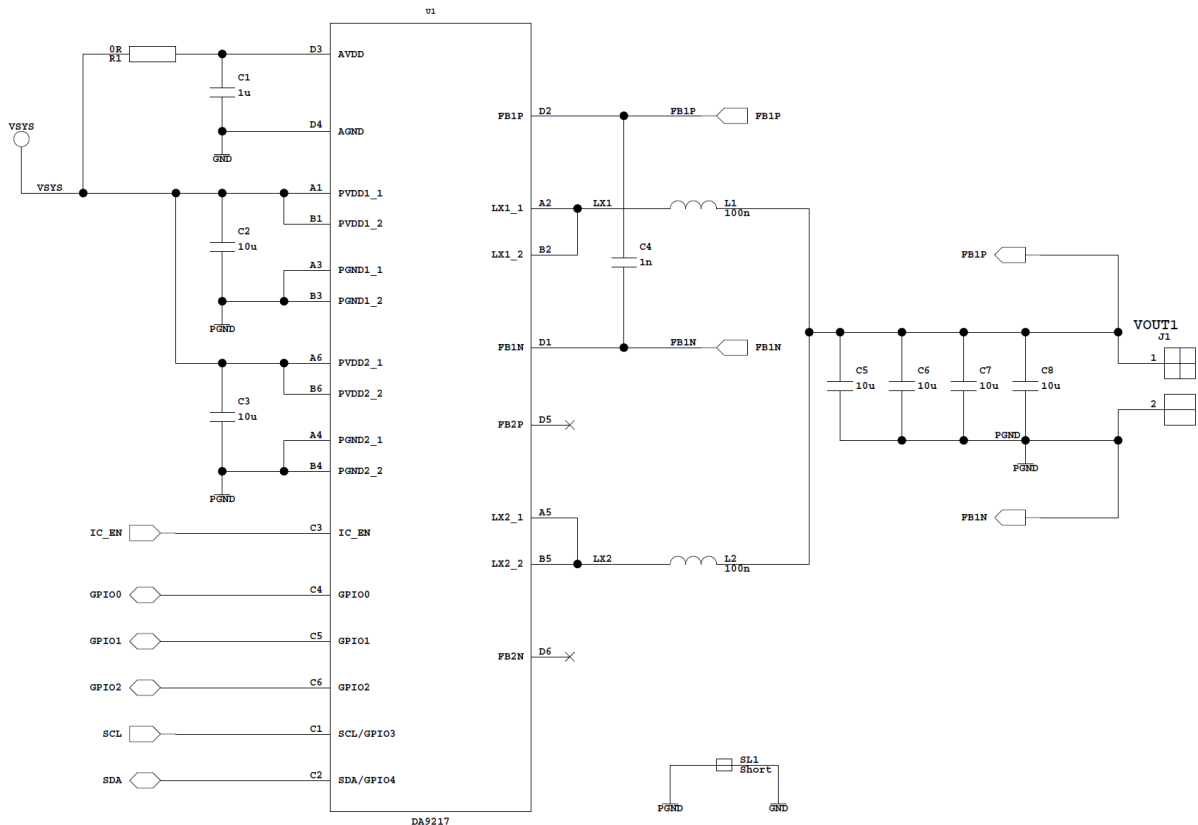

Figure 1: DA9217/DA9121 Recommended Components and Connections

DA9217/DA9220/DA9121/DA9122 - Adjusting VOUT above 1.9 V

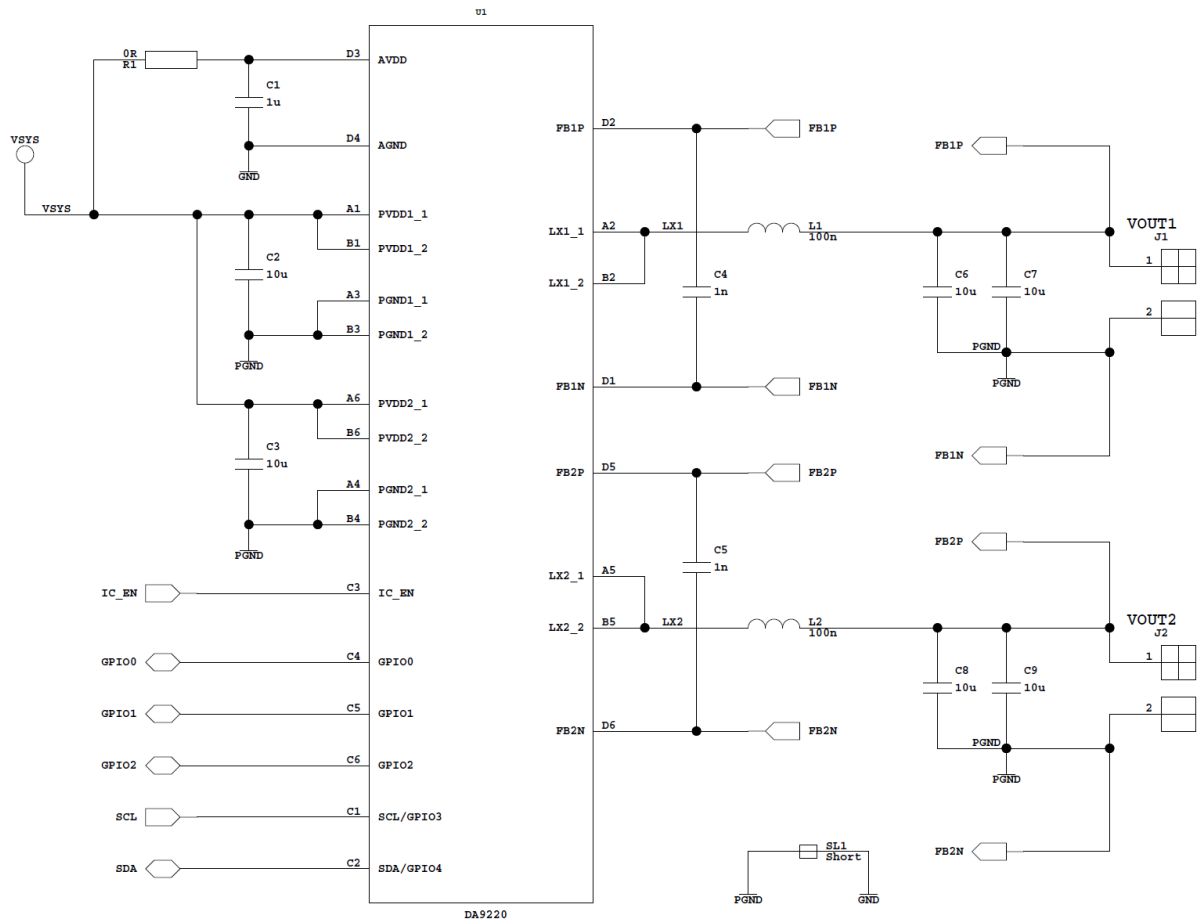

Figure 2: DA9220/DA9122 Recommended Components and Connections

DA9217/DA9220/DA9121/DA9122 - Adjusting V_{OUT} above 1.9 V

4 Output Voltage Programming

Use the GUI software to set up the output voltage in the range of 0.3 V to 1.9 V.

DA9217/DA9121/DA9220/DA9122 can support output voltages higher than 1.9 V using an external resistive divider shown in Figure 3. To calculate the output voltage with an external divider, use the following equation:

$$V_{OUT} = V_{REF} \times \left(1 + \frac{R1}{R2}\right)$$

V_{REF} is the device buck output voltage setting, see Figure 4.

Use resistors for R1+R2 below 40 kΩ.

NOTE

The resistors need to be properly selected since the output voltage accuracy will be directly affected by any errors on the resistors. The voltage across FB1P and FB1N (V_{REF}) is guaranteed, but not the output voltage accuracy.

To operate the circuit properly, a feedforward capacitor (C_{FF}) in parallel with R1 is required. Use capacitances for C_{FF} in the range of 1 nF to 4.7 nF.

Examples:

1. To regulate a 3.3 V output voltage from a 5 V input voltage, use a 10 kΩ resistor on both R1 and R2, with V_{REF} set to 1.65 V and C_{FF}=2.2 nF.
2. To regulate a 2.5 V output voltage from a 5 V input voltage, use a 10 kΩ resistor on both R1 and R2, with V_{REF} set to 1.25 V and C_{FF}=2.2nF.

When using an external resistive divider to program the buck converter output voltage, a minimum difference of 1.2 V between V_{IN} and V_{OUT} is required. This is due to a maximum controllable on-time limitation. For example, to regulate a 3.3 V output voltage, the minimum input voltage should be 4.5 V.

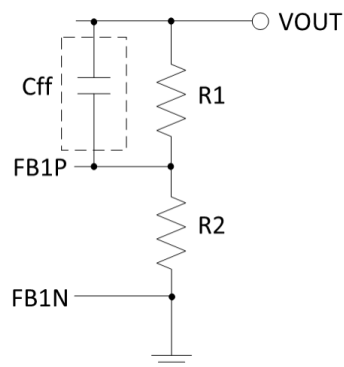

Figure 3: Resistive Divider Diagram

DA9217/DA9220/DA9121/DA9122 - Adjusting VOUT above 1.9 V

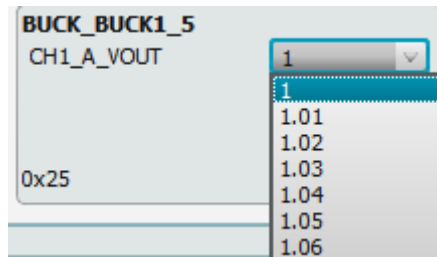

Figure 4: Register of Buck Output Setting

4.1 Waveform Results

Figure 5. to Figure 8 show the output voltage higher than 1.9 V using DA9217; R1 = R2 = 20 kΩ, CFF = 2.2 nF.

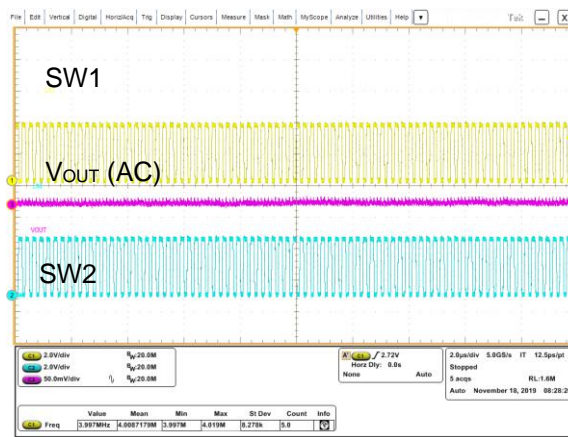

Figure 5: VIN = 3.7 V, VOUT = 2 V, IOUT = 3 A, CFF = 2.2 nF

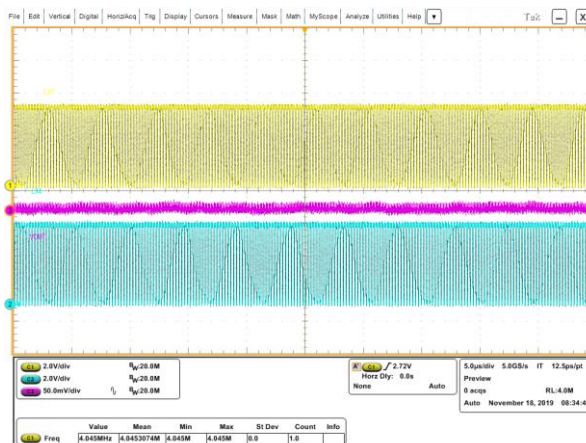

Figure 6: VIN = 5 V, VOUT 3.3 V, IOUT = 3 A, CFF = 2.2 nF

**DA9217/DA9220/DA9121/DA9122 - Adjusting
VOUT above 1.9 V****5 Conclusions**

DA9217/DA9121/DA9220/DA9122 allow output voltages in the range from 0.3 V to 1.9 V by internal setting. These devices also support output voltages above 1.9 V by using an external resistive divider and a capacitor. The application note describes how to choose the required component values to realize this higher output voltage.

**DA9217/DA9220/DA9121/DA9122 - Adjusting
VOUT above 1.9 V****Revision History**

Revision	Date	Description
1	23-Jan-2020	Initial version.
1.1	15-Feb-2022	Rebranded to Renesas.

DA9217/DA9220/DA9121/DA9122 - Adjusting VOUT above 1.9 V

Status Definitions

Status	Definition
DRAFT	The content of this document is under review and subject to formal approval, which may result in modifications or additions.
APPROVED or unmarked	The content of this document has been approved for publication.

RoHS Compliance

Dialog Semiconductor's suppliers certify that its products are in compliance with the requirements of Directive 2011/65/EU of the European Parliament on the restriction of the use of certain hazardous substances in electrical and electronic equipment. RoHS certificates from our suppliers are available on request.

DA9217/DA9220/DA9121/DA9122 - Adjusting VOUT above 1.9 V

Important Notice and Disclaimer

RENESAS ELECTRONICS CORPORATION AND ITS SUBSIDIARIES ("RENESAS") PROVIDES TECHNICAL SPECIFICATIONS AND RELIABILITY DATA (INCLUDING DATASHEETS), DESIGN RESOURCES (INCLUDING REFERENCE DESIGNS), APPLICATION OR OTHER DESIGN ADVICE, WEB TOOLS, SAFETY INFORMATION, AND OTHER RESOURCES "AS IS" AND WITH ALL FAULTS, AND DISCLAIMS ALL WARRANTIES, EXPRESS OR IMPLIED, INCLUDING, WITHOUT LIMITATION, ANY IMPLIED WARRANTIES OF MERCHANTABILITY, FITNESS FOR A PARTICULAR PURPOSE, OR NON-INFRINGEMENT OF THIRD PARTY INTELLECTUAL PROPERTY RIGHTS.

These resources are intended for developers skilled in the art designing with Renesas products. You are solely responsible for (1) selecting the appropriate products for your application, (2) designing, validating, and testing your application, and (3) ensuring your application meets applicable standards, and any other safety, security, or other requirements. These resources are subject to change without notice. Renesas grants you permission to use these resources only for development of an application that uses Renesas products. Other reproduction or use of these resources is strictly prohibited. No license is granted to any other Renesas intellectual property or to any third party intellectual property. Renesas disclaims responsibility for, and you will fully indemnify Renesas and its representatives against, any claims, damages, costs, losses, or liabilities arising out of your use of these resources. Renesas' products are provided only subject to Renesas' Terms and Conditions of Sale or other applicable terms agreed to in writing. No use of any Renesas resources expands or otherwise alters any applicable warranties or warranty disclaimers for these products.

© 2022 Renesas Electronics Corporation. All rights reserved.

(Rev.1.0 Mar 2020)

Corporate Headquarters

TOYOSU FORESIA, 3-2-24 Toyosu

Koto-ku, Tokyo 135-0061, Japan

www.renesas.com

Contact Information

For further information on a product, technology, the most up-to-date version of a document, or your nearest sales office, please visit:

<https://www.renesas.com/contact/>

Trademarks

Renesas and the Renesas logo are trademarks of Renesas Electronics Corporation. All trademarks and registered trademarks are the property of their respective owners.

IMPORTANT NOTICE AND DISCLAIMER

RENESAS ELECTRONICS CORPORATION AND ITS SUBSIDIARIES (“RENESAS”) PROVIDES TECHNICAL SPECIFICATIONS AND RELIABILITY DATA (INCLUDING DATASHEETS), DESIGN RESOURCES (INCLUDING REFERENCE DESIGNS), APPLICATION OR OTHER DESIGN ADVICE, WEB TOOLS, SAFETY INFORMATION, AND OTHER RESOURCES “AS IS” AND WITH ALL FAULTS, AND DISCLAIMS ALL WARRANTIES, EXPRESS OR IMPLIED, INCLUDING, WITHOUT LIMITATION, ANY IMPLIED WARRANTIES OF MERCHANTABILITY, FITNESS FOR A PARTICULAR PURPOSE, OR NON-INFRINGEMENT OF THIRD-PARTY INTELLECTUAL PROPERTY RIGHTS.

These resources are intended for developers who are designing with Renesas products. You are solely responsible for (1) selecting the appropriate products for your application, (2) designing, validating, and testing your application, and (3) ensuring your application meets applicable standards, and any other safety, security, or other requirements. These resources are subject to change without notice. Renesas grants you permission to use these resources only to develop an application that uses Renesas products. Other reproduction or use of these resources is strictly prohibited. No license is granted to any other Renesas intellectual property or to any third-party intellectual property. Renesas disclaims responsibility for, and you will fully indemnify Renesas and its representatives against, any claims, damages, costs, losses, or liabilities arising from your use of these resources. Renesas' products are provided only subject to Renesas' Terms and Conditions of Sale or other applicable terms agreed to in writing. No use of any Renesas resources expands or otherwise alters any applicable warranties or warranty disclaimers for these products.

(Disclaimer Rev.1.01)

Corporate Headquarters

TOYOSU FORESIA, 3-2-24 Toyosu,
Koto-ku, Tokyo 135-0061, Japan
www.renesas.com

Trademarks

Renesas and the Renesas logo are trademarks of Renesas Electronics Corporation. All trademarks and registered trademarks are the property of their respective owners.

Contact Information

For further information on a product, technology, the most up-to-date version of a document, or your nearest sales office, please visit www.renesas.com/contact-us/.