

Application note

DA905x Touch screen interface

AN-PM-001

Abstract

The touch screen interface (TSI) of DA9052 and DA9053 offer compatibility with 4-wire resistive touch screens and support pen pressure measurements. Since it has many user-programmable controls, including TSI pre-charging and settling time delay, and configurable sample rates up to a maximum of 3 kHz, it is ideal for different battery-powered systems, such as PDAs, PMPs, and smartphones. This application note offers insight into the theory of operation and explains step-by-step how to configure the device for an application.

Contents

Abstract	1
Contents	2
Figures	2
Tables	3
1 Terms and definitions	3
2 References	3
3 Resistive touch screen: principle of operation	4
3.1 Construction	4
3.2 X and Y measurements.....	4
3.3 Z (pressure) measurement.....	5
3.4 Pen-down detection	6
4 Power modes within TSI	7
4.1 Low power mode	7
4.2 Active reading mode	8
5 TSI parameters	10
5.1 TSI_DELAY	12
5.1.1 Built-in impedances	12
5.1.2 External bypass capacitors.....	12
5.2 TSI_SKIP	13
6 Application cases	16
6.1 XP mode (hard coded buttons)	16
6.2 Frames identification on displays (soft coded buttons).....	17
6.3 Hand writing recognition.....	17
7 PCB layout guidelines	19
7.1 Noise	19
7.2 Resistance	20
Revision history	21

Figures

Figure 1: Structure of a resistive touch screen.....	4
Figure 2: Example of reading the X- position (Y- position uses the same principle).....	5
Figure 3: Example of reading P_{TOUCH} (needed for Z measurements).....	5
Figure 4: Example of pen down sensing	6
Figure 5: Flow chart for low power operation	7
Figure 6: Flow chart for active reading operation	9
Figure 7: ADC sequence	10
Figure 8: Sampling activity of TSI.....	11
Figure 9: System built-in impedances	12
Figure 10: Sampling activity of TSI for different values of TSI_DELAY and TSI_SKIP = 2	13
Figure 11: Effect of TSI_DELAY and TSI_SKIP settings	15
Figure 12: Example of application of XP mode	16
Figure 13: Suggested application connections.....	18
Figure 14: Recommended layout to prevent from noise.	19
Figure 15: Effect of high board track resistance in TSI applications	20

Tables

Table 1: Maximum frequency achievable with different TSI_DELAY and TSI_SKIP combinations ... 14

1 Terms and definitions

DA905x	DA9052 or DA9053
TSI	Touch Screen Interface
PET	PolyEthylene Terephthalate
ITO	Indium Tin Oxide
PMP	Personal Media Player
PDA	Personal Digital Assistant

2 References

- [1] DA9052-00-PDS2b_110802.pdf, DA9052 Datasheet, Dialog Semiconductor
- [2] DA9053-00-PDS3a_140114.pdf, DA9053 Datasheet, Dialog Semiconductor

3 Resistive touch screen: principle of operation

3.1 Construction

A resistive touch screen consists of three layers (see Figure 1):

- A first conductive ITO thin film, coating a flexible membrane made of PET
- A second conductive ITO thin film, coating a rigid substrate made of glass or acrylic
- A layer of insulating spacer between the two ITO thin films

In 4-wire touch screens, each ITO layer has a pair of electrodes mounted at the ends of the surface (also called ‘bus bars’). The bus bars in the top and bottom sheets are perpendicular to each other. The bus bars are connected to DA905x’s TSI through the four wires referred as X+, X-, Y+, and Y-.

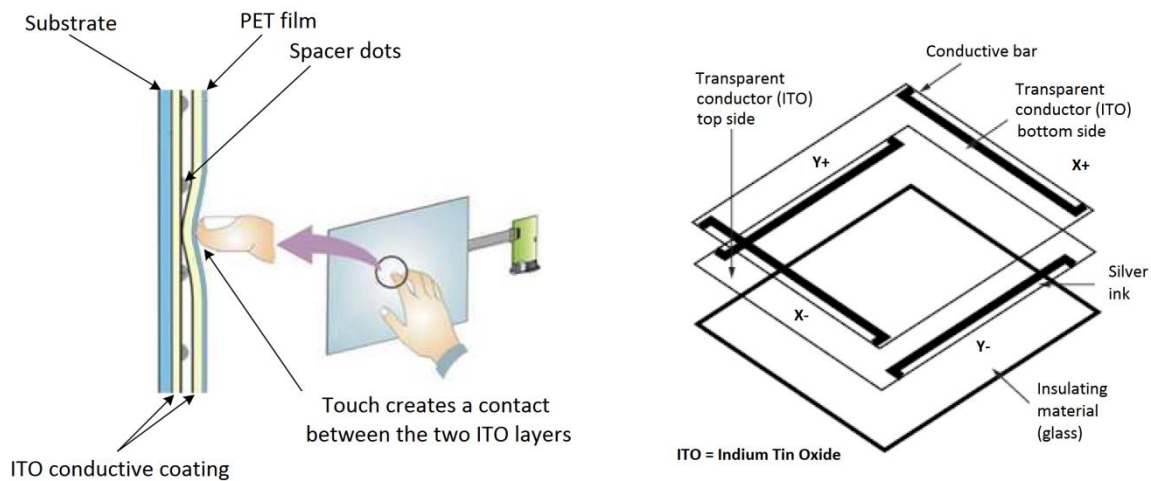

Figure 1: Structure of a resistive touch screen

3.2 X and Y measurements

By pressing the panel with a finger or a pen, the two ITO layers are put in contact with each other and a resistive voltage divider is created. A voltage is applied between the bus bars of either the X or Y layers and a voltage is sensed on the other layer. From this voltage reading, the relative position between the bus bars can be deduced (see Figure 2). Typically, the total resistance of each panel layer is between 500 Ω and 2 kΩ for most products in the market.

- A measurement of the X position is made by connecting X+ to the positive supply, X- to the negative supply and sensing the voltage on the Y+ pin.
- A measurement of the Y position is made by connecting Y+ to the positive supply, Y- to the negative supply and sensing the voltage on the X+ pin.

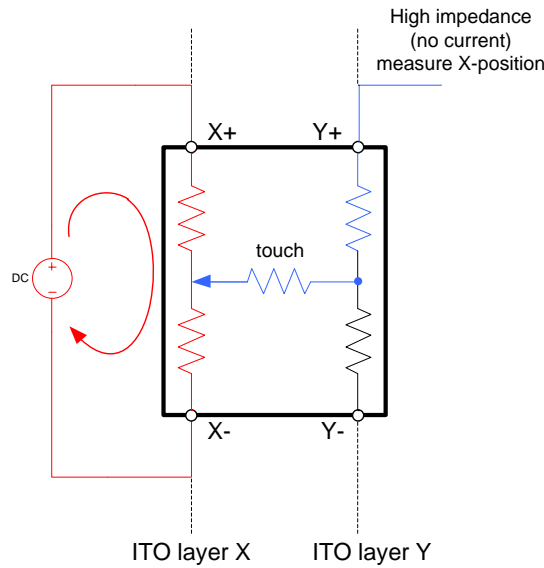

Figure 2: Example of reading the X- position (Y- position uses the same principle)

3.3 Z (pressure) measurement

DA905x’s TSI circuitry allows measuring touch pressure (Z measurement). For this both the X and Y plates’ resistance needs to be known. The pen pressure can then be estimated as parameter $R_{PRESSURE}$, calculated in the following formula:

$$R_{PRESSURE} = \frac{R_X \cdot X}{1024} \cdot \left(\frac{1024}{P_{TOUCH}} - 1 \right) - R_Y \cdot \left(1 - \frac{Y}{1024} \right)$$

where R_X and R_Y are the known resistances of the TSI X and Y plates, X and Y are the measured coordinates measured in the previous section and P_{TOUCH} is measured using the method illustrated in Figure 3.

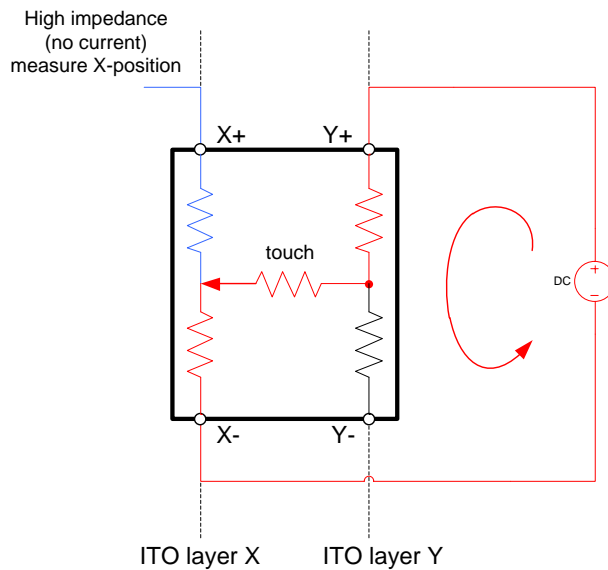

Figure 3: Example of reading P_{TOUCH} (needed for Z measurements)

3.4 Pen-down detection

Pen-down detection is the first measurement at the start of a TSI acquisition sequence and it is performed as depicted in Figure 4. A small pull-up current is connected between DA905x's internal supply VDDCORE and the X+ point of the panel through a switch. The Y- is also grounded through a switch.

The input of the pen touch sensing comparator is normally pulled up by the current source, but when a pen or finger contacts the panel the X plate is connected to the Y panel, creating a low impedance path to ground (indicated by the red path in Figure 4). Under these conditions the comparator switches and signals a PEN DOWN to the control logic. The interrupt E_PEN_DOWN is created in register R6 and (if in POWERDOWN mode) a wakeup issued. The wakeup can be masked.

Please refer to the DA9052 [1] or DA9053 [2] datasheet for a complete technical description of DA905x's TSI and for all electrical parameters.

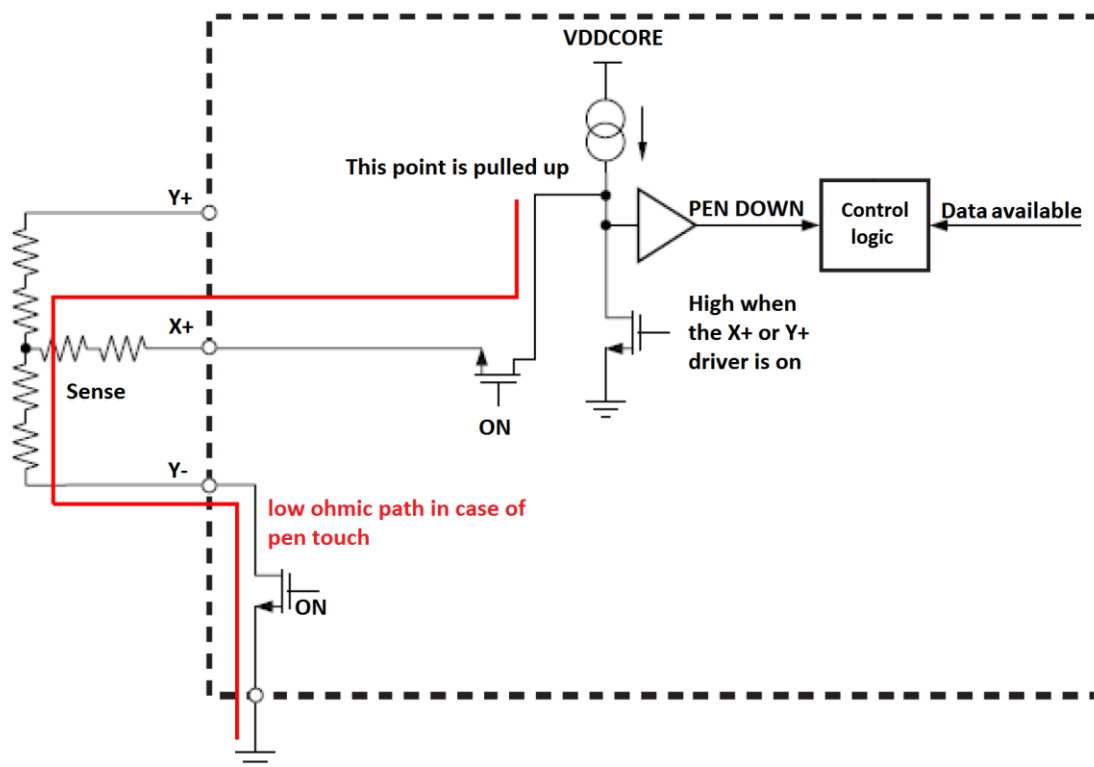

Figure 4: Example of pen down sensing

4 Power modes within TSI

There are two modes for TSI operation:

- Low power mode
- Active reading mode

4.1 Low power mode

In the low power mode configuration, the TSI circuitry is internally supplied by DA905x's core voltage VDDCORE. This is provided by an internal voltage regulator capable of supplying a few milliamps of current and is needed for the basic operation of the PMIC.

The X+ pin of the TSI panel is pulled-up by a small current source connected to VDDCORE (see pen down sensing concept of [Figure 4](#)).

To start TSI activity, the host processor has to configure register R105, PEN_DET_EN = 1 and AUTO_TSI_EN = 0.

In this state, the system is waiting for a PEN DOWN event and the power consumption is minimised. Measurement of X- and Y- (which would require more current) is not yet activated.

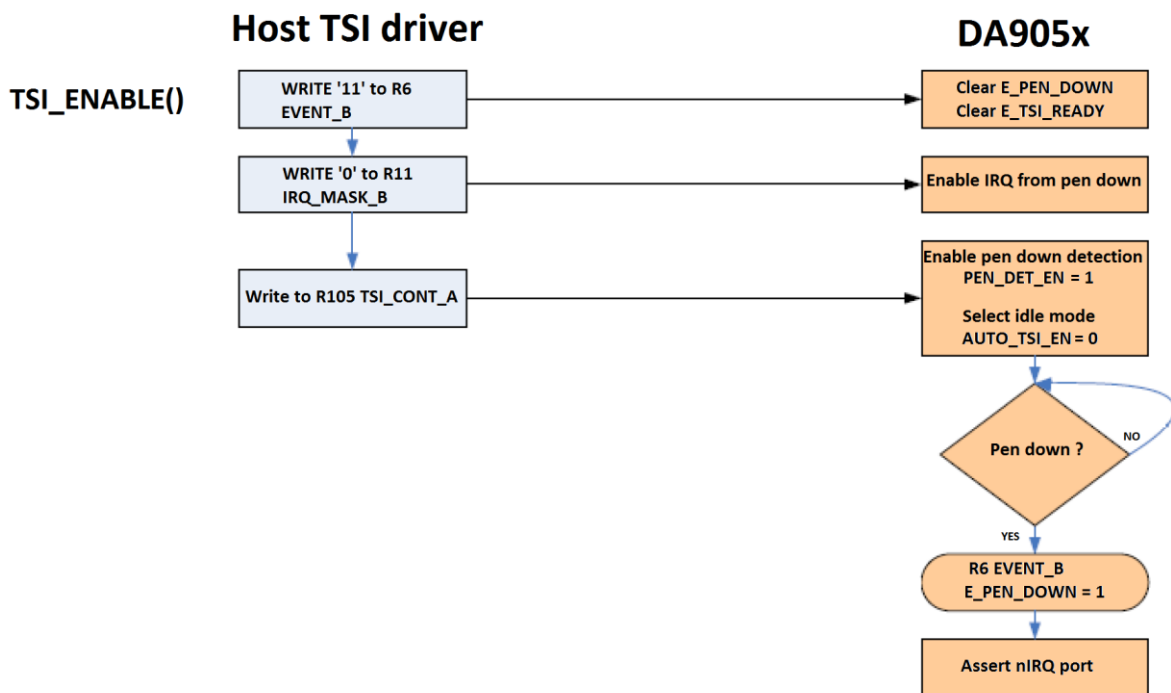

Figure 5: Flow chart for low power operation

4.2 Active reading mode

Active mode is started after the first PEN DOWN event is detected. DA905x asserts the nIRQ port and issues an interrupt E_PEN_DOWN to the host processor, which needs to respond with an appropriate IRQ service routine.

The automatic X-, Y- and Z- measurements are activated by the host by writing PEN_DET_EN = 0 and AUTO_TSI_EN = 1 in register R105.

After enabling AUTO_TSI_EN the supply automatically changes from VDDCORE to TSIREF pin. This should be supplied from a low noise LDO capable supplying tens of milliamps. The voltage supplied by DA905x LDO9 is suggested for this purpose.

The total dissipated power is higher than in low power mode and depends on the frequency of operation and on the panel's impedance, since the panel must be repetitively charged and discharged at this frequency.

X-, Y- and Z- measurements are performed in active reading mode with an interrupt based procedure (see [Figure 6](#)). The values are measured by the TSI and stored in registers R107 to R110. The host processor reads the values and then clears the interrupt. The values measured by DA905x are not updated until the host clears the related interrupt.

Each measurement must be validated by the host by checking the PEN_DOWN bit of register R109. If the bit is not asserted, the read values should be discarded. If the bit is asserted, the host should use the read values.

The active mode is ended when a TSI time out timer expires.

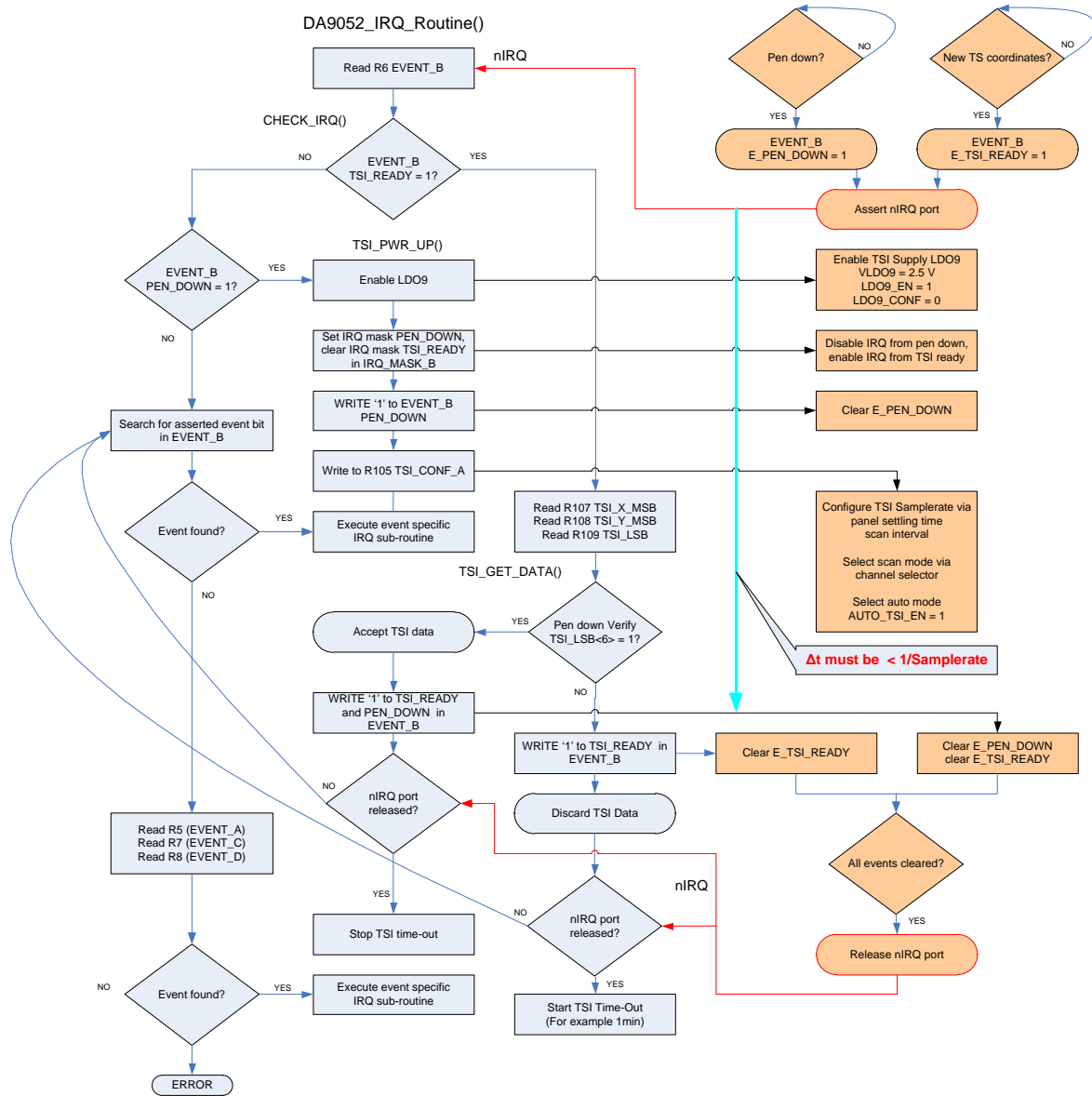

Figure 6: Flow chart for active reading operation

5 TSI parameters

The TSI of DA905x can be configured for different applications and may be optimized for speed or current consumption.

The TSI operates as a sub-system within the general ADC scheduler (see Figure 7 and refer to DA905x datasheet for further details). The scheduler performs a sequence of 10 slots, repeatedly. When the TSI is enabled (in both low power and active modes), the second half of each slot performs TSI actions and measurements.

The conversion rate can be set as high speed (period 1ms) or economy mode (period 10 ms) in register R82.

For TSI activities, high speed mode is always recommended. This is achieved by setting the bit ADC_MODE = 1.

Independently of ADC_MODE settings, each slot of the scheduler always requires 100 μs. The actual frequency of TSI measurements depends on the settings of the two main parameters TSI_SKIP and TSI_DELAY, both selectable in register R105.

Example sequence of AUTO-ADC measurements

Slot No	0	1	2	3	4	5	6	7	8	9											
	A0	X	M	Y	M	Z	A4	P	M	X	M	Y	A6	P	TSI, no charging, TSI_DELAY<=1, TSI_SKIP=0						
	A0	X	A1	Y	M	Z	A4	P	A2	-	M	-	A5	X	A6	Y	M	P	A8	-	TSI, with charging TSI_DELAY<=1, TSI_SKIP=2 slots
	A0	M	M	A4	M	M	A5	M	M	A6	No TSI, no charging										
	A0	A1	M	A4	A2	M	A5	A6	M	A8	No TSI, with charging										

Each Slot allows 1 automatic or manual measurement and 1 TSI measurement to be made
 A0 - Automatic measurement of VDDOUT (mux channel 0)
 A1 - Automatic measurement of ICH (mux channel 1)
 A2 - Automatic measurement of TBAT (mux channel 2)
 A4 - Automatic measurement of ADCIN4 (mux channel 4)
 A5 - Automatic measurement of ADCIN5 (mux channel 5)
 A6 - Automatic measurement of ADCIN6 (mux channel 6)
 A8 - Automatic measurement of Tjunc with gain 3 (mux channel 8)
 TSI - Automatic X&Y(&Z) measurement followed by a pen detection (mux channel 7)
 M indicates time slots when a Manual measurement can be made

Figure 7: ADC sequence

In order to better understand the meaning of TSI_SKIP and TSI_DELAY parameters, the sampling activity of TSI is demonstrated in Figure 8.

- The first three grey blocks show the time needed to wait for the voltage to become stable and the measurement reliable (see TSI_DELAY)
- The last two grey areas on the right side represent a time in which no measurements are performed and no driving of the panel takes place, thus it is an idle time to reduce acquisition frequency and current consumption (see TSI_SKIP)

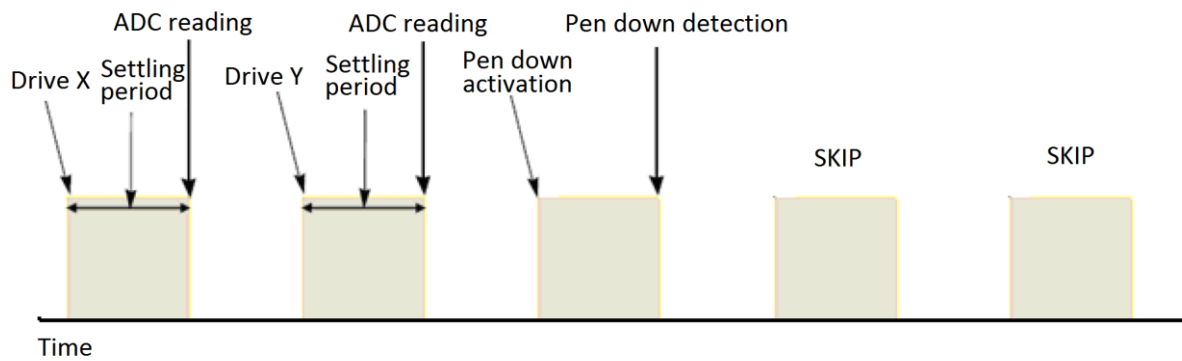

Figure 8: Sampling activity of TSI

5.1 TSI_DELAY

Touch screen measurements are done by switching on and off voltages on bus bars in rapid sequence. When the voltages are switched, the input signal will require a settling time before it reaches its true value. TSI_DELAY is the delay time between closing the X and Y switches and an ADC measurement.

It can be set to 6 μs , 56 μs , 156 μs , or 256 μs . Increasing the delay results in a lower overall TSI operating frequency.

There are two reasons for setting a higher settling time: built-in impedances and external bypass capacitors.

5.1.1 Built-in impedances

The capacitive elements within the touch panel need to be considered. Distributed across the ITO layers are parasitic capacitors. The total capacitance can be modelled by two parallel capacitors C_P (see Figure 9). Together with the layer resistances and additional parasitic resistances due to connections, these capacitances form a low pass filter with a certain time constant.

The value of the time constant depends on the touch screen used in the application. For example, with $C_P = 50 \text{ nF}$ and $R_{TOT} = 1 \text{ k}\Omega$, the time constant is 100 μs . In this case, a safe value would be TSI_DELAY=256 μs .

5.1.2 External bypass capacitors

Depending on the specific application, some LCD noise can interfere with the measurement or mechanical vibrations can distort the acquisition. Therefore, some external capacitors are often added at the inputs X+, X-, Y+ and Y-. These, in conjunction with the panel resistance, also form a low pass filter. This delay should be considered and added, when choosing the TSI_DELAY value.

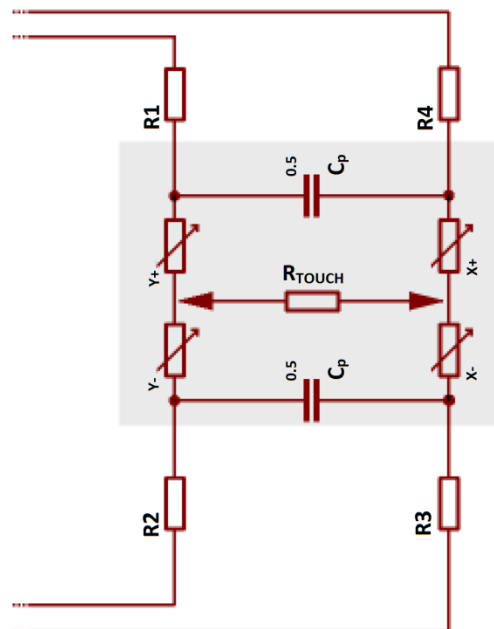

Figure 9: System built-in impedances

5.2 TSI_SKIP

This parameter defines the delay between two consecutive measurements in the sequence X, Y, Z, and P. During the slots assigned as TSI_SKIP no measurements are made, the X and Y switches are open, and no current flows through the touch screen, thus reducing the average current consumption.

The minimum value for TSI_SKIP is 0. In other words: continuous operation. In this case, the maximum operating frequency for the TSI is 3 kHz. The maximum value for TSI_SKIP is 330 slots, which limits the operating frequency to a maximum of 30 Hz.

While the TSI_DELAY is a parameter specifically related to the touch screen performance and noise in the application, the TSI_SKIP can be set according to the specific data rate versus power consumption trade off, needed in the application.

Both parameters combine to define the overall operating frequency.

To explain the meaning of TSI_SKIP and TSI_DELAY parameters, examples of the TSI's sampling activity are shown in Figure 10.

In Figure 10:

- The first half of each slot is reserved for other ADC measurements (here indicated as "M"). In the second half, the TSI acquisition is done with some settling time (TSI_DELAY). Since TSI_SKIP = 2, some grey areas can be identified, in which no TSI activity is present.
- The first row shows the slots sequence, each slot being of a fixed length of 100 μs.
- The second and third rows (with TSI_DELAY set respectively to 6 μs and 56 μs) define the same TSI frequency, although with a different settling time.
- In the last two rows (with TSI_DELAY set respectively to 156 μs and 256 μs), different values of TSI_DELAY define different TSI frequencies.

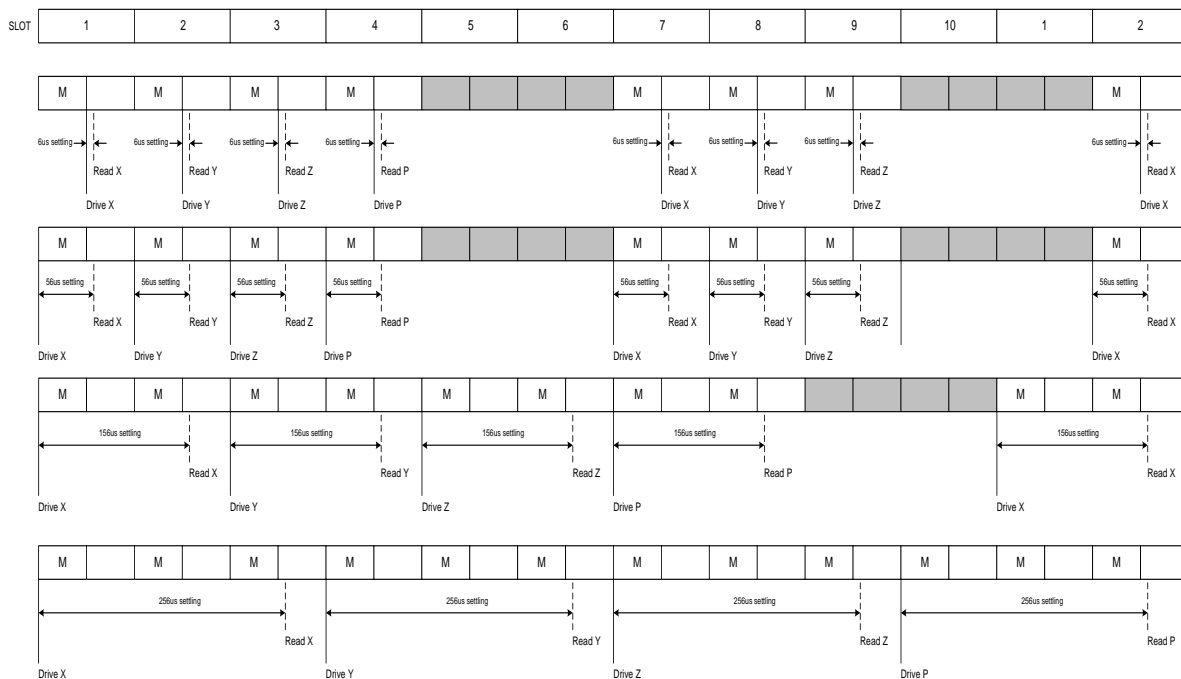

Figure 10: Sampling activity of TSI for different values of TSI_DELAY and TSI_SKIP = 2

Based on the slot diagrams of [Figure 10](#), the maximum frequency that can be achieved by the TSI can be calculated by using the following formula:

$$f_{MAX} = \frac{3 \text{ kHz}}{n_TSI_DELAY \cdot [1 + 0.3 \cdot (n_TSI_SKIP)]}$$

where n_TSI_DELAY is the number of slots for TSI_DELAY and n_TSI_SKIP is the number of slots for TSI_SKIP (see [Table 1](#)).

Table 1: Maximum frequency achievable with different TSI_DELAY and TSI_SKIP combinations

TSI_DELAY		TSI_SKIP (slots)							
		0	2	5	10	30	80	130	330
(µs)	(slots)								
6	1	3000.0	1875.0	1200.0	750.0	300.0	120.0	75.0	30.0
56	1	3000.0	1875.0	1200.0	750.0	300.0	120.0	75.0	30.0
156	2	1500.0	937.5	600.0	375.0	150.0	60.0	37.5	15.0
256	3	1000.0	625.0	400.0	250.0	100.0	40.0	25.0	10.0

Figure 11 illustrates the effect of different TSI_DELAY and TSI_SKIP settings on the accuracy of the touch screen results.



Figure 11: Effect of TSI_DELAY and TSI_SKIP settings

- The green values are taken with the correct settings. The samples clearly show that all points on the touch screen can be measured correctly. Plenty of samples are gathered all over the screen.
- If the TSI_DELAY is set too small, then the range of values read from the screen is severely limited. In this case the signal does not have enough time to settle, so the input value is being measured while the signal is still ramping up to its true value. This is illustrated by the red samples with large areas of the screen not being registered as having been touched.
- If TSI_DELAY and TSI_SKIP are too large, then not enough samples are measured to gain sufficient information from the screen. The black samples illustrate this: the time between samples is too long. If the touched position moves quickly, not enough samples are taken to track the changes.

6 Application cases

In the following sections, some different application cases will be considered and the correct parameter settings will be discussed.

6.1 XP mode (hard coded buttons)

In register R105, setting TSI_MODE = 1 selects XP mode. In this configuration, each X measurement is followed immediately by a pen down detection and no Y or Z measurements are performed.

This mono-dimensional sensing is not applicable to touch screen panels, but rather is used for other applications such as hard coded buttons.

Figure 12 depicts an example of such an application, with three hard buttons. When one of them is pressed, a certain voltage is detected at the output of the voltage divider.

The 1.2 V comparator implemented in DA905x can be used to activate the TSI in XP mode. The output of the voltage divider is normally pulled down to ground. When a button is pressed, a voltage higher than 1.2 V is detected at the input of the comparator, which connects the voltage divider to the TSI X-input.

By selecting proper values of the resistors R1, R2, R3, and R4, the TSI is able to identify which button was pressed, because different voltages are generated on the voltage divider (for example, possible values are TSI_REF = 2.5 V, R1 = 8 k Ω , R2 = 4 k Ω , R3 = 2 k Ω and R4 = 10 k Ω).

The XP application of Figure 12 does not require high speed (15 Hz is more than sufficient). It is suggested to choose low frequency values from Table 1. For example, TSI_SKIP = 330 slots and TSI_DELAY = 156 μ s.

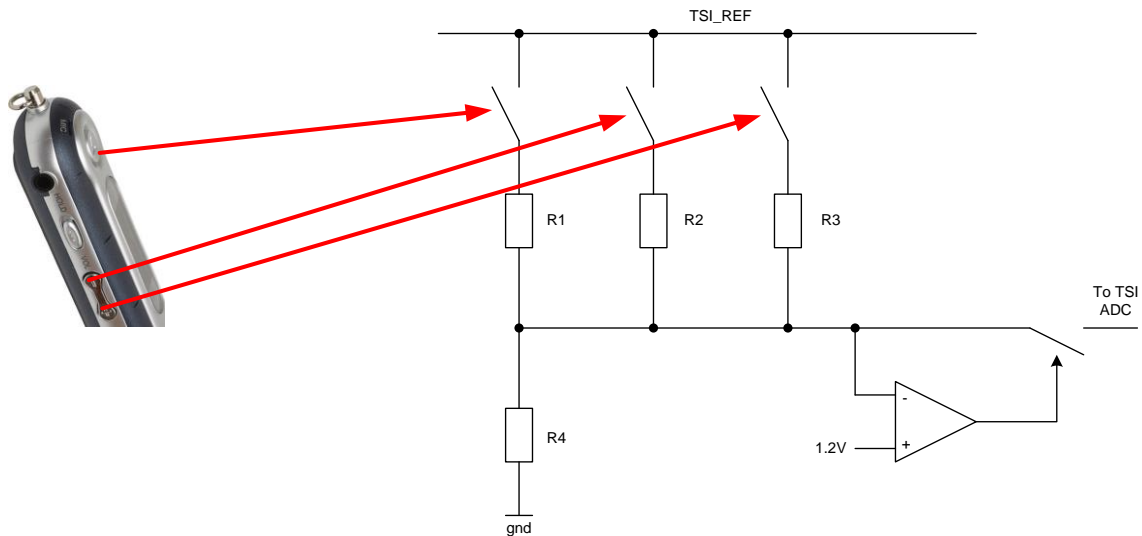

Figure 12: Example of application of XP mode

6.2 Frames identification on displays (soft coded buttons)

The association of patterns and frames on a display with possible software functionalities is a common application in portable devices with touch screens. An example of this is the soft keyboard, scroll buttons, icons, and such.

To serve these kinds of applications, a full X and Y measurement must be activated on DA905x by setting `TSI_MODE = 0`.

A high frequency is not needed, therefore a mid-range frequency, around 100 Hz, can be selected from [Table 1](#). For example, `TSI_SKIP = 80` slots and `TSI_DELAY = 56 μs`. Alternatively, `TSI_SKIP = 30` slots and `TSI_DELAY = 156 μs` can be selected if a higher delay is needed for noisy application environments (at the cost of increased current consumption).

By choosing low or middle range operating frequencies for these applications, the interface between DA905x and the host processor only requires medium traffic and reduces power consumption. Therefore, it is recommended to use the lowest possible sample rates on the TSI.

6.3 Hand writing recognition

This represents one of the most critical applications for the TSI. A minimum of 100 samples per second are needed for correct hand writing recognition and they need to be precise values. To achieve this, each value should be the averaged result of a minimum of ten raw TSI measurements and therefore, mandates a minimum TSI sample rate of 1 kHz.

The suggested values for this application are `TSI_SKIP = 5` slots (to give a maximum sampling frequency of 1.2 kHz) and `TSI_DELAY = 56 μs` or `156 μs`, depending on the quality of the touch panel.

If lower frequencies are selected, the quality of the recognition will be affected.

If higher frequencies are selected, the interface (SPI or I²C) between DA905x and the host may be over-loaded due to high traffic. This will depend on the speed of the host processor, the maximum handling frequency of the interrupt routine, and to a certain extent, the number of parallel tasks running in the portable device. If the host processor is committed for baseband, displays, camera, audio, or other activities, there could be a lack of resources for TSI activities.

NOTE

DA905x's TSI does not offer averaged samples; only the original values are transmitted on the interface for processing by the host processor

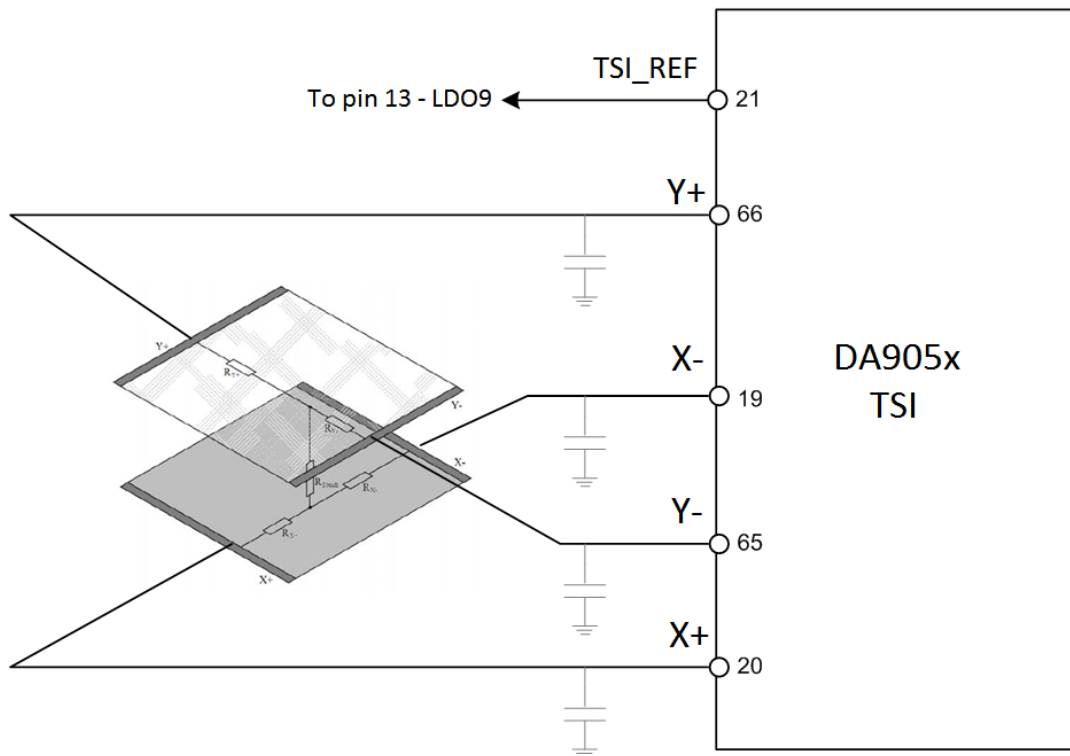

Figure 13: Suggested application connections

7 PCB layout guidelines

The implementation of good circuit board connections is a very important part for the correct operation of DA905x's TSI. Below are some suggestions to achieve the best performance.

7.1 Noise

The touch screen tracks X+, X-, Y+, and Y- are sensitive lines. Noise can be captured by these tracks if the line is too long and placed close to noisy lines. For example, some digital data lines as well as the I²C or SPI lines.

Recommendations:

- Prevent the tracks overlapping with any noisy signal lines. If an overlap is unavoidable, insert GND separation between touch screen and noisy lines.
- Place GND shielding on each side of touch screen track routing.
- Route the touch screen tracks as short as possible.

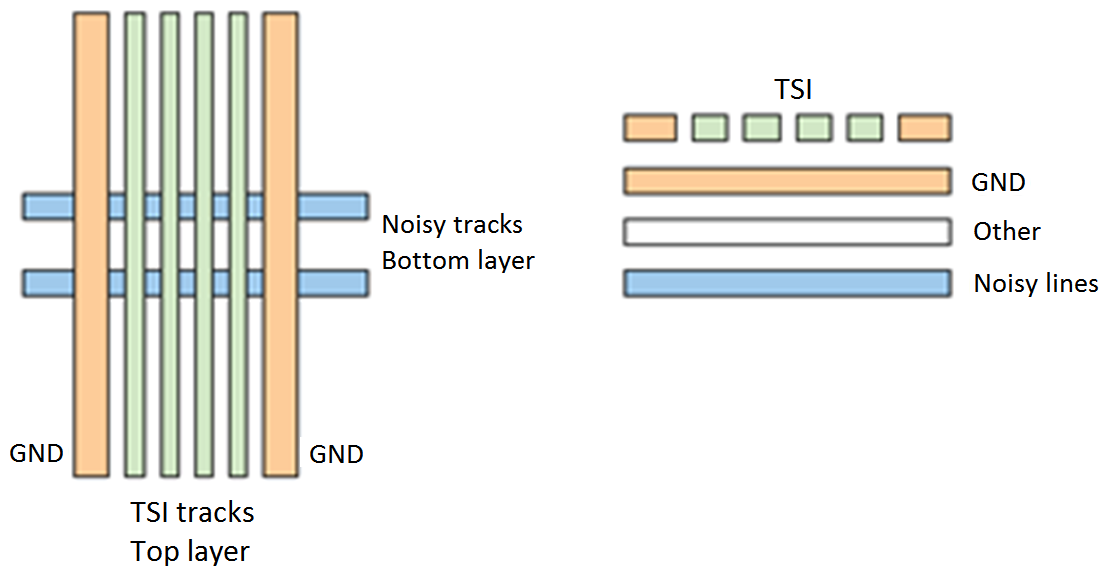

Figure 14: Recommended layout to prevent from noise.

Some filtering capacitors can be placed on the touch screen tracks to suppress noise (see [Figure 13](#) as optional grey connections). In this case, the best location for the filtering capacitor is as near as possible to DA905x.

The values for the filtering capacitors should be selected as appropriate for the TSI sampling rate (see [Section 6.3](#)) as follows:

- 1 nF to 2 nF are typical values for LCDs smaller than 6 inches.
- 5 nF to 10 nF are typical values for LCDs bigger than 6 inches.

7.2 Resistance

Any track will have an amount of resistance, thus reducing the effective resolution of the TSI. During the measurement, current flows to the touch screen panel through the tracks. The track resistance combined with the current flowing creates a voltage drop across the track resistance reducing the effective voltage applied to the panel terminals.

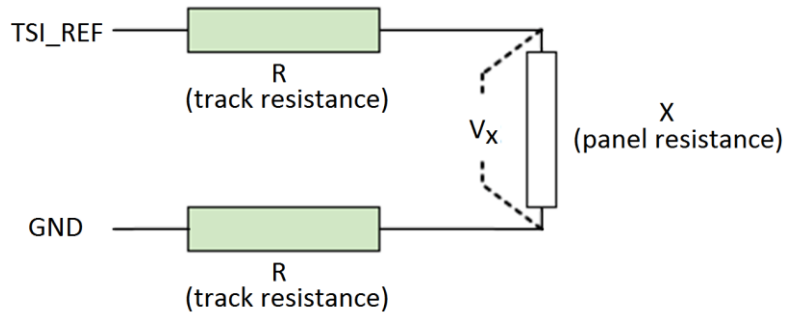

Figure 15: Effect of high board track resistance in TSI applications

Due to track resistance, the voltage at the panel's terminals V_x is:

$$V_x = \frac{X}{X + 2R} \cdot TSI_REF$$

Hence, the effective resolution is reduced by the same factor as well.

The track resistance can be reduced by designing the track to be as short and wide as possible.

DA905x switches that connect the touch screen panel to TSI_REF and GND introduce additional resistance. To overcome this problem, it is possible to connect the ADC directly to the panel instead of to the TSI_REF supply. This is done by setting in register R106, ADCREF = 1.

Revision history

Revision	Date	Description
2.2	19-May-2016	Minor changes following review.
2.1	06-Apr-2016	Minor changes following review.
2.0	14-Mar-2016	Conversion to new corporate template. Update to information.
1.0	16-Apr-2009	Initial version.

Status definitions

Status	Definition
DRAFT	The content of this document is under review and subject to formal approval, which may result in modifications or additions.
APPROVED or unmarked	The content of this document has been approved for publication.

Disclaimer

Information in this document is believed to be accurate and reliable. However, Dialog Semiconductor does not give any representations or warranties, expressed or implied, as to the accuracy or completeness of such information. Dialog Semiconductor furthermore takes no responsibility whatsoever for the content in this document if provided by any information source outside of Dialog Semiconductor.

Dialog Semiconductor reserves the right to change without notice the information published in this document, including without limitation the specification and the design of the related semiconductor products, software and applications.

Applications, software, and semiconductor products described in this document are for illustrative purposes only. Dialog Semiconductor makes no representation or warranty that such applications, software and semiconductor products will be suitable for the specified use without further testing or modification. Unless otherwise agreed in writing, such testing or modification is the sole responsibility of the customer and Dialog Semiconductor excludes all liability in this respect.

Customer notes that nothing in this document may be construed as a license for customer to use the Dialog Semiconductor products, software and applications referred to in this document. Such license must be separately sought by customer with Dialog Semiconductor.

All use of Dialog Semiconductor products, software and applications referred to in this document are subject to Dialog Semiconductor's [Standard Terms and Conditions of Sale](#), unless otherwise stated.

© Dialog Semiconductor. All rights reserved.

RoHS Compliance

Dialog Semiconductor complies to European Directive 2001/95/EC and from 2 January 2013 onwards to European Directive 2011/65/EU concerning Restriction of Hazardous Substances (RoHS/RoHS2).

Dialog Semiconductor's statement on RoHS can be found on the customer portal <https://support.diasemi.com/>. RoHS certificates from our suppliers are available on request.

Contacting Dialog Semiconductor

United Kingdom (Headquarters)

Dialog Semiconductor (UK) LTD
Phone: +44 1793 757700

Germany

Dialog Semiconductor GmbH
Phone: +49 7021 805-0

The Netherlands

Dialog Semiconductor B.V.
Phone: +31 73 640 8822

Email:

enquiry@diasemi.com

North America

Dialog Semiconductor Inc.
Phone: +1 408 845 8500

Japan

Dialog Semiconductor K. K.
Phone: +81 3 5425 4567

Taiwan

Dialog Semiconductor Taiwan
Phone: +886 281 786 222

Web site:

www.dialog-semiconductor.com

Singapore

Dialog Semiconductor Singapore
Phone: +65 64 8499 29

Hong Kong

Dialog Semiconductor Hong Kong
Phone: +852 3769 5200

Korea

Dialog Semiconductor Korea
Phone: +82 2 3469 8200

China (Shenzhen)

Dialog Semiconductor China
Phone: +86 755 2981 3669

China (Shanghai)

Dialog Semiconductor China
Phone: +86 21 5424 9058

IMPORTANT NOTICE AND DISCLAIMER

RENESAS ELECTRONICS CORPORATION AND ITS SUBSIDIARIES (“RENESAS”) PROVIDES TECHNICAL SPECIFICATIONS AND RELIABILITY DATA (INCLUDING DATASHEETS), DESIGN RESOURCES (INCLUDING REFERENCE DESIGNS), APPLICATION OR OTHER DESIGN ADVICE, WEB TOOLS, SAFETY INFORMATION, AND OTHER RESOURCES “AS IS” AND WITH ALL FAULTS, AND DISCLAIMS ALL WARRANTIES, EXPRESS OR IMPLIED, INCLUDING, WITHOUT LIMITATION, ANY IMPLIED WARRANTIES OF MERCHANTABILITY, FITNESS FOR A PARTICULAR PURPOSE, OR NON-INFRINGEMENT OF THIRD-PARTY INTELLECTUAL PROPERTY RIGHTS.

These resources are intended for developers who are designing with Renesas products. You are solely responsible for (1) selecting the appropriate products for your application, (2) designing, validating, and testing your application, and (3) ensuring your application meets applicable standards, and any other safety, security, or other requirements. These resources are subject to change without notice. Renesas grants you permission to use these resources only to develop an application that uses Renesas products. Other reproduction or use of these resources is strictly prohibited. No license is granted to any other Renesas intellectual property or to any third-party intellectual property. Renesas disclaims responsibility for, and you will fully indemnify Renesas and its representatives against, any claims, damages, costs, losses, or liabilities arising from your use of these resources. Renesas' products are provided only subject to Renesas' Terms and Conditions of Sale or other applicable terms agreed to in writing. No use of any Renesas resources expands or otherwise alters any applicable warranties or warranty disclaimers for these products.

(Disclaimer Rev.1.01)

Corporate Headquarters

TOYOSU FORESIA, 3-2-24 Toyosu,
Koto-ku, Tokyo 135-0061, Japan
www.renesas.com

Trademarks

Renesas and the Renesas logo are trademarks of Renesas Electronics Corporation. All trademarks and registered trademarks are the property of their respective owners.

Contact Information

For further information on a product, technology, the most up-to-date version of a document, or your nearest sales office, please visit www.renesas.com/contact-us/.