

OB1203

OB1203 Heart Rate, Blood Oxygen Concentration, Pulse Oximetry, Proximity, Light and Color Sensor: RGB

Abstract

This application note introduces color sensing with OB1203. The IDT OB1203 all-in-one RGB color sensor/proximity sensor/PPG biosensor has a 4 channel color sensor with red, green, blue and white ambient light sensing channels. The ambient light sensor offers a wide field of view in a compact 2 × 4.2 × 1.2 mm package and offers

The application note introduces the concepts and basic methods for converting RGBW color measurements to useful lux and correlated color temperature (CCT) for mobile applications such as display brightness and color adjustment.

Contents

- 1. Application Circuit.....3**
- 2. Color Sensing with OB1203.....3**
 - 2.1 Dark Current/Temperature Compensation.....3
 - 2.2 RGB Settings.....3
 - 2.2.1. RGB Resolution and Sample Period4
 - 2.2.2. RGB Gain Control4
 - 2.2.3. RGB Interrupt Thresholds4
 - 2.3 OB1203 Light Sensor FOV5
 - 2.4 Cover Glass Aperture Placement6
- 3. Color, Lux and Color Temperature Estimation7**
 - 3.1 RGB Color Correction.....7
 - 3.2 Lux Calculation10
 - 3.3 CCT Calculation11
- 4. Revision History13**

Figures

- Figure 1. Application Circuit.....3
- Figure 2. RGB Field of View in the Portrait Orientation5
- Figure 3. Optical Element Locations within the Package.....6
- Figure 4. Ink Hole Placement7
- Figure 5. CIE 1931 Standard Observer Human Eye Response8
- Figure 6. CIE 1931 xy Color Space8
- Figure 7. RGB Spectra and Color Corrected Spectra.....9
- Figure 8. Lux Accuracy for Five OB1203 Devices and 13 Light Sources10
- Figure 9. The Planckian Locus and Lines of Equal CCT in the UV Color Space.....11
- Figure 10. The Planckian Locus and Lines of Equal CCT in XY Color Space11

Figure 11. Linearized CCT 12
Figure 12. CCT Accuracy for Five OB1203 Devices and 13 Light Sources..... 12

1. Application Circuit

It is suggested to use low noise power supply sources, such as low-noise low dropout (LDO) linear regulators. Independent supplies for analog and digital supply (VDD) and LED supply (LED_VDD or LVDD) are suggested. Pull-up resistors in the appropriate range to microcontroller logic voltage of 1.8–3.3V are necessary for I2C SDA, I2C SCL and INTB pins. A decoupling cap between VDD and analog ground (GND) of 0.1µF and optionally 1µF for longer leads is suggested. 4.7-10 µF capacitors are useful between LVDD and LED_GND (LGND). The analog ground (GND) and LED power ground (LGND) should be connected at a low impedance node to avoid ground bounce effects when the LED current is high. Trace lengths should be minimized and wider trace/via widths used for current carrying LVDD and LGND lines. All the LED pins should be connected to a low thermal impedance pad.

For bench test functionality purposes it is sufficient to connect LVDD and VDD to 3.3V source relative to LGND and GND, and connect the I2C and INTB lines to the logic level (typically 1.8V or 3.3V) via pull-up resistors in the appropriate range. Note that the internal digital and analog levels are set by an internal LDO regulator.

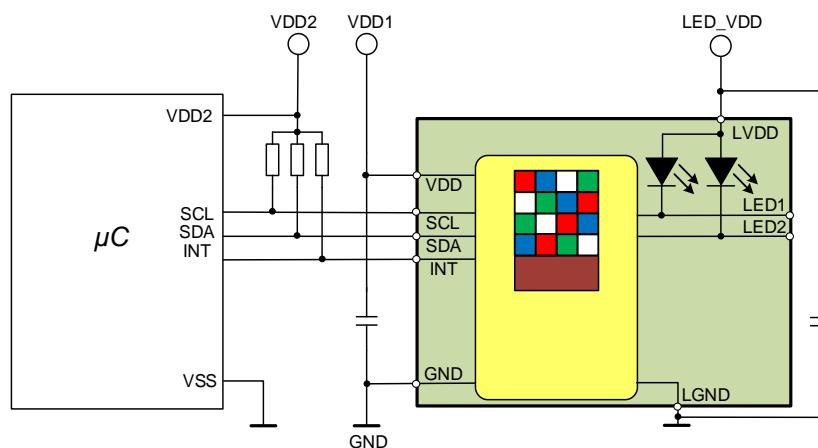

Figure 1. Application Circuit

2. Color Sensing with OB1203

The OB1203 ambient light color sensor measures five channels simultaneously: red, green, blue, white and comp. The Comp channel is for compensating temperature dependent dark current. The comp photodiode is obscured by a metal layer so the only current detected is thermally generated dark (leakage) current. The color channels use a high extinction, low angle shift infrared cut filter which provides stable color measurements over the field of view.

2.1 Dark Current/Temperature Compensation

Photodiodes have a small thermally-generated photocurrent called “dark current”, which shows up as a positive offset at elevated temperatures that is detectable at low ambient light levels. The dark current is measured by the comp channel and automatically subtracted from the color channels. The output value of the light sensor registers equals the measured ADC counts on each color, less the comp channel ADC value. For example,

$$Red_{register} = Red_{ADC} - Comp_{ADC}$$

For application of alternative temperature compensation strategies, the “comp” or “dark” value that was subtracted can be read at registers 0x10–0x12, as described in the datasheet.

2.2 RGB Settings

OB1203 has configurable registers for RGB settings including resolution, gain, sample period, and ambient light interrupt thresholds.

2.2.1. RGB Resolution and Sample Period

RGB measurement resolution scales with the ADC integration time. Doubling the resolution (aka integration time) will half the maximum data output rate. Lower resolution measurements offer fast sample rates.

Sample period can be set to any time equal to or greater than the integration time. Longer sample periods introduce a delay between measurements. For example, with 18-bit resolution (100ms integration time) sample periods of 100, 200, 500, 1000 and 2000 ms are selectable.

For display adjustment applications, high resolution measurements are used for low light level sensing. Typical handset applications will use 50ms or 100ms integration time. These integration times are multiples of both 60Hz and 50Hz periods and are useful for reducing ambient light flicker.

2.2.2. RGB Gain Control

OB1203 has a common programmable gain which is applied to all the ambient light sensor channels. Increasing the gain delivers a lower minimum detectable signal (LSB) and correspondingly decreases the maximum detectable signal. The gain should be decreased when the ambient light is so large that it may saturate the ADC, or increased when the signal is small and improved resolution is needed.

A typical algorithm for gain control includes two count thresholds. When all measurements fall below the low threshold, the gain should be increased. When any measurement of interest goes above the high threshold, gain should be reduced. The low threshold should be set such that when the gain is changed the expected count value should be higher than the threshold. This type of hysteresis provides stability and avoids rapid toggling of gain.

Note that RGBW measurements are LSB aligned. This means that the threshold values must be scaled according to the full scale count value. Full scale = $(2^N - 1)$, where N = bits of resolution. Resolution is set by register 0x22 bits 6:4.

Current Gain	Low Threshold	High Threshold	Notes
1x	N/A	90% of full scale	(Minimum gain, maximum range)
3x	10% of full scale	90% of full scale	(Default gain)
6x	10% of full scale	90% of full scale	(Maximum recommend gain for high accuracy color)
20x (on available models)	10% of full scale	N/A	(Expect increasing channel gain variation at very high gain)

2.2.3. RGB Interrupt Thresholds

OB1203 includes an ambient light sensor (LS) interrupt feature which pulls the interrupt pin low when a specified condition occurs. Ambient interrupts can be used to detect a handset being covered or uncovered, or to detect large changes in ambient intensity such as going outside in bright sunlight, so the handset may override the normal ambient light intensity filter time constant and set the display brightness immediately to maximum brightness.

The LS interrupt feature can be enabled or disabled and has programmable high and low thresholds. When the ambient light interrupt is enabled, the INTB pin will be pulled low when a measurement below the low threshold or above the high threshold occurs. Reading the status register releases the interrupt. The LS channel (color) to be compared with the interrupt thresholds is set by the interrupt configuration register 0x2B. Any of the four colors can be chosen for the interrupt. For display adjustment, the green channel is recommend which has a spectrum that makes the best a good approximation of lux, or perceived brightness.

The LS interrupt persistence, set by INT_PST register 0x2D, sets the number of successive measurements below or above the threshold which must occur before the interrupt is asserted.

There is also a unique interrupt mode called LS Variation which can be selected instead of the default threshold interrupt mode. This feature compares the current sample to the previous sample. In this mode, successive LS measures which differ by more than the amount set in the LS_THRES_VAR register (0x2A) will trigger the interrupt. Persistence applied to this interrupt feature means that each successive measurement must differ from the sample immediately previous by more than the variation threshold.

NOTE: For regular threshold LS interrupts, the interrupts values programmed into the register are directly compared to the sensor value. So if the gain or resolution is changed, the LS interrupts should be scaled accordingly.

2.3 OB1203 Light Sensor FOV

The field of view (FOV) of the light sensor channels is limited by the opening of the window in the OB1203 OSIP package. In the long direction of package the measured light intensity nominally drops to 50% of the normal incidence intensity at 45°, providing a full width at half maximum (FWHM) of 90°. In the short direction of the package the FOV nominally drops to 50% of the normal incidence intensity at 50°, offering a FWHM of 100°.

The long direction of the package is typically horizontal with a handset in portrait mode. Referring to Figure 2, the up-down FOV is 100° and the left-right FOV is 90°.

Notably, all colors have approximately the same FOV. With traditional dielectric filters the filter passband blue-shifts with angle of incidence causing the blue signal to grow and the red signal to drop, relative to green, meaning blue has a larger field of view and red is narrower. However, OB1203's advanced color filters provide a largely angle-independent transmission for red, green and blue, such that a significant color shift is not observed for off-axis illumination less than about 40°.

Beyond the package-limited FOV, a portion of the light sensors are shadowed by the package, which can alter the measured color. To reduce this affect the RGB sensor is centered in the package window and the respective color photodiodes have been divided into a 4x4 array of color subpixels. The subpixels are arranged such that each row and column has one of each type of color subpixel. The achieved FOV in the end application may also depend on the thickness of the cover glass, the air gap between the sensor and cover glass and the aperture through any opaque bezel ink.

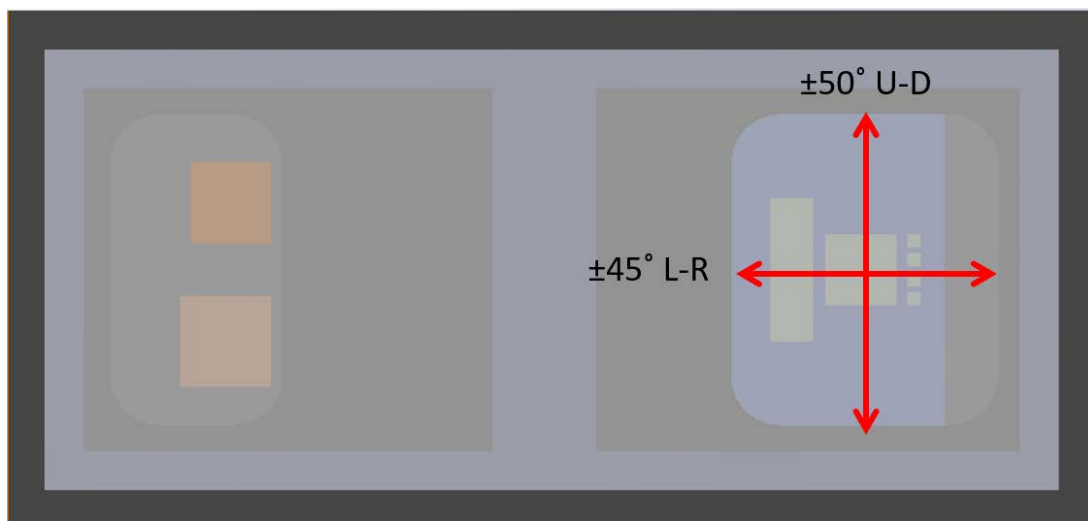

Figure 2. RGB Field of View in the Portrait Orientation

2.4 Cover Glass Aperture Placement

In common handset applications the cover glass of the phone includes an opaque ink layer in the bezel outside the display region (on the inside surface of the glass over the top of any aesthetic color layer). Circular openings in the bezel allow the proximity LEDs to transmit infrared (IR) light and the proximity photodiode to receive reflected light, as well as the light sensors to receive ambient light. The sensor apertures should be centered over the RGB array and the LED aperture located at least 2.6mm away. Sensor apertures may be covered with IR-transmissive ink, so-called IR ink. The transmission of the ink in the range greater than 690nm should be at least 80% for proper function of the biosensor. Figure 3 shows the relative locations of the optical elements in OB1203 for alignment of the cover glass apertures. Figure 4 shows the respective FWHM fields of view of the LEDs and RGB sensors along with appropriately aligned 2mm diameter apertures.

A variety of appropriate IR inks can be supplied by companies such as Teikoku and Seiko (Japan), or distributors.

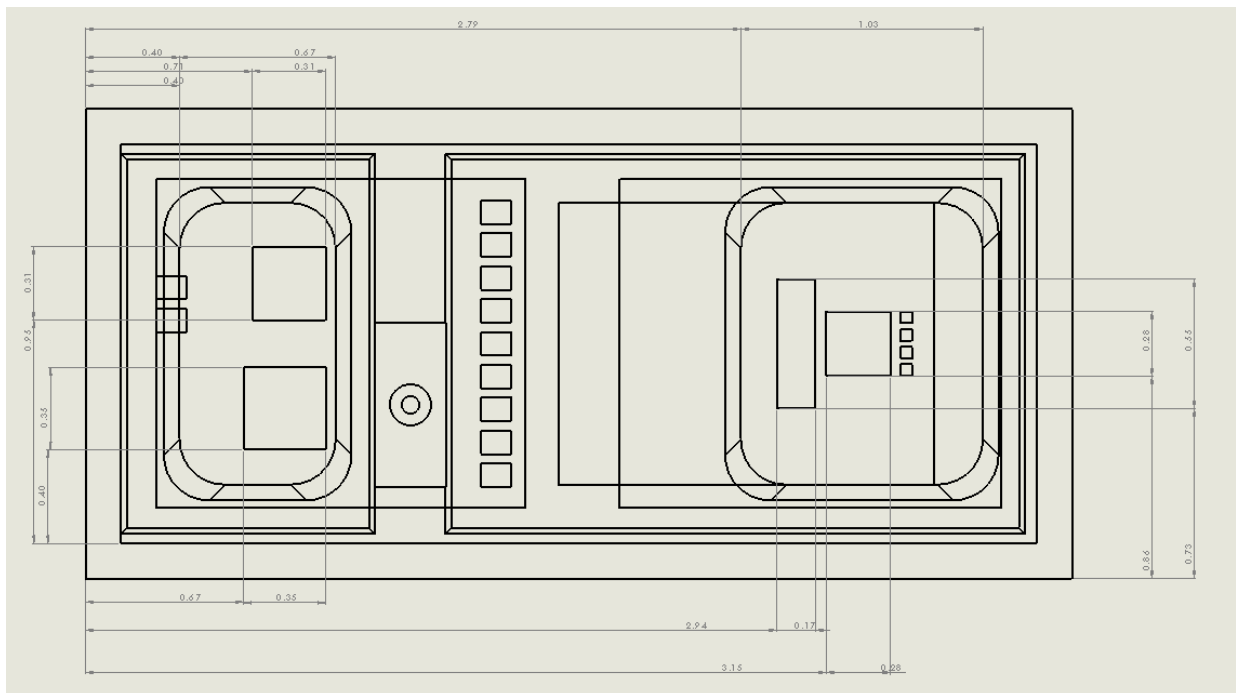

Figure 3. Optical Element Locations within the Package

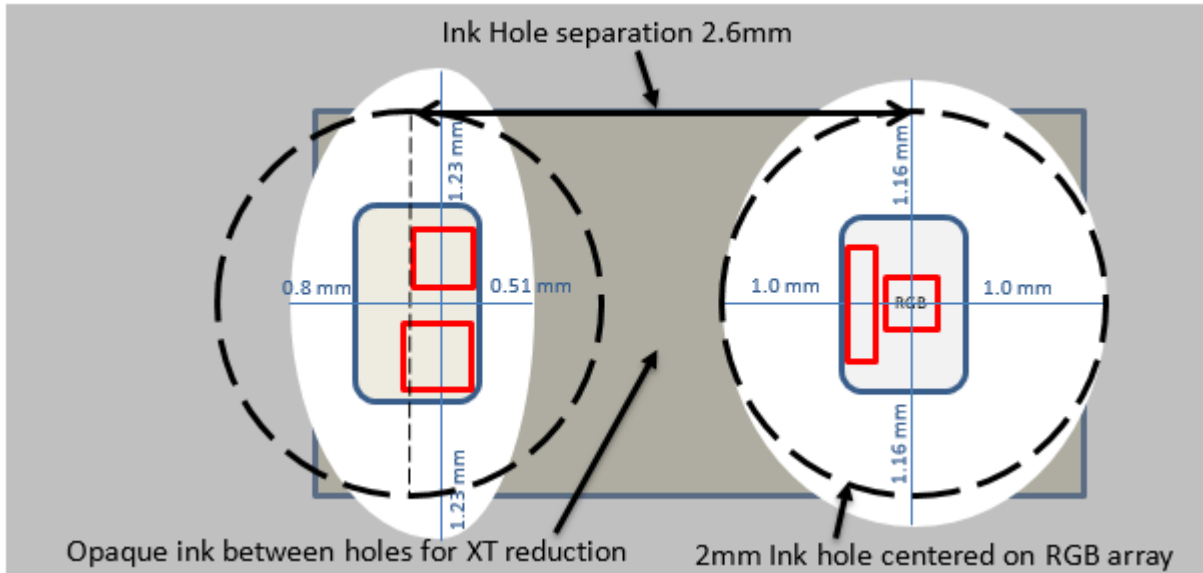

Figure 4. Ink Hole Placement

3. Color, Lux and Color Temperature Estimation

3.1 RGB Color Correction

The RGB color sensor has a wavelength response which differs from the human eye. Human perception of color has been classified by various representations including the CIE XYZ representation, where X is red, Y is green and Z is blue. In the representation, or conformal map, there is a degree of freedom. The Y value has been chosen to follow the total light sensitivity of the human eye photopic response. The second degree of freedom was used to make the photoresponse curves strictly positive.

The human eye and brain perform a kind of “spectral compression” on color, reducing the many wavelengths of incident light into approximately 3 points. Thus, light viewed by a person is a 3-dimensional space. However, we can use one axis for total observed light intensity (Y), like a radius in spherical coordinates. The Y measurement is the SI unit of lux. That leaves two other axes for the actual color. The xyY color space uses Y for the total light intensity. For the two color axes we use normalized “little xyz” colors which are always between zero and one.

$$x = \frac{X}{(X + Y + Z)}$$

$$y = \frac{Y}{(X + Y + Z)}$$

$$z = \frac{Z}{(X + Y + Z)}$$

Once we know total light intensity, we only need two of these normalized colors to represent the color fully. For the common xyY color space, the x (redness) and y (greenness) were chosen. The xy color space is shown in Figure 6. The colors displayable by a typical monitor are shown as a limited gamut in the center. In the xy color space, individual wavelengths trace the upper boundary of the color space, where color overlap is minimal. Unlike Cartesian spaces, X, Y and Z (or x, y, and z) are not orthogonal. If you increase one value, based on the overlap of the human eye response spectra, you also increase the others. Because the green and red colors overlap, the reddest possible color still has some green (y), and blue always generates some red response (x).

Only for the wavelength at which the red response goes to zero does the locus of wavelengths touch the y axis.

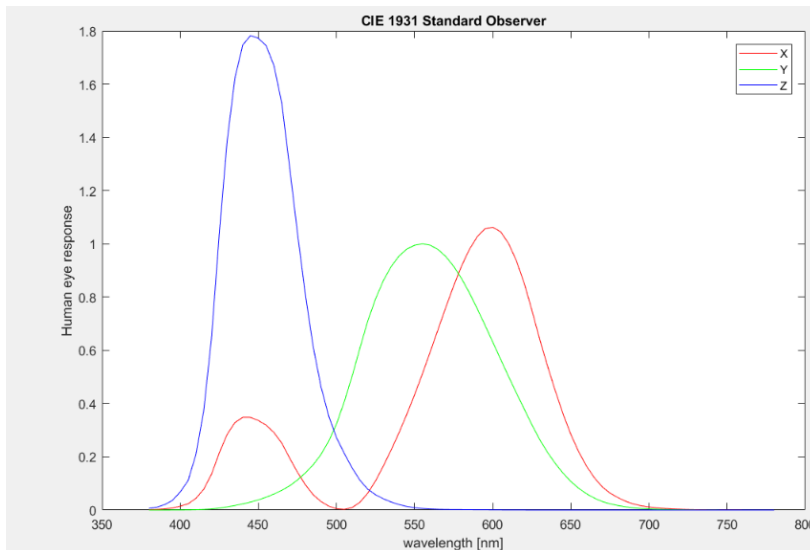

Figure 5. CIE 1931 Standard Observer Human Eye Response

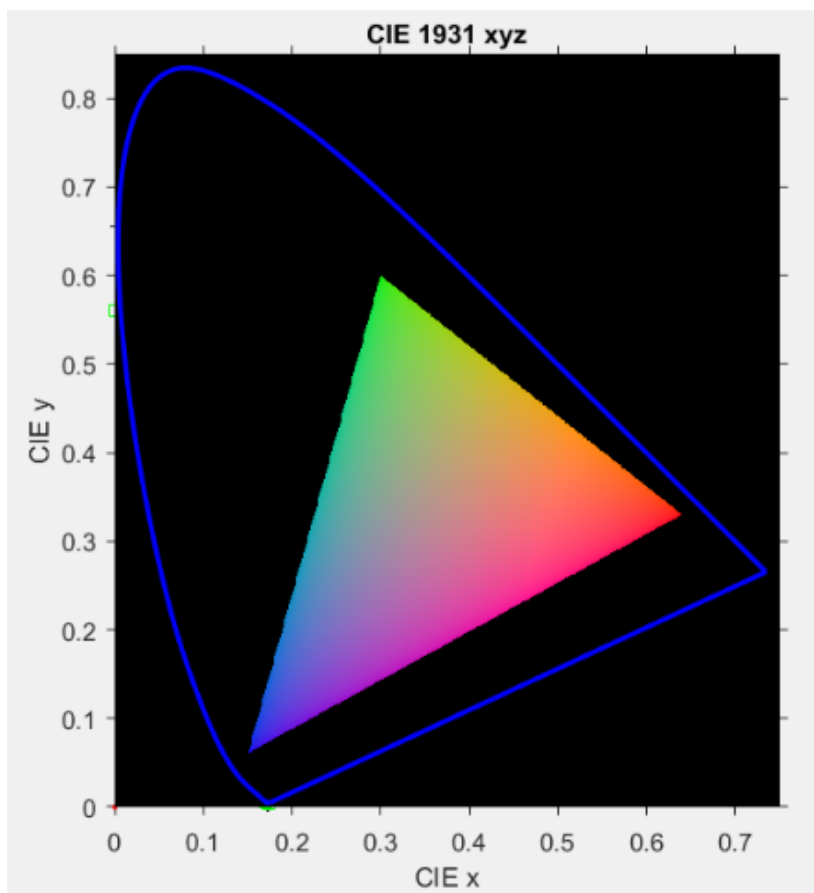

Figure 6. CIE 1931 xy Color Space

For light sensors with response different from an ideal XYZ detector, it is possible to generate linear combinations of the measured colors to best approximate what a human observer would see.

As an example consider the OB1203 green channel. Its peak is slightly blue-shifted relative to the human eye Y response. By adding a small amount of red we shift the peak to better overlap with the Y curve. However, we still have too much response in the blue region. So we subtract a small amount of blue. Then we scale the color-corrected value to match a reference lux meter. This same process is done to generate X and Z responses as well. The three sets of coefficients for calculating XYZ values from RGB counts are combined into a convenient color-correction (CC) matrix.

$$\begin{bmatrix} X' \\ Y' \\ Z' \end{bmatrix} = \begin{bmatrix} c_{11} & c_{12} & c_{13} \\ c_{21} & c_{22} & c_{23} \\ c_{31} & c_{32} & c_{33} \end{bmatrix} \begin{bmatrix} R \\ G \\ B \end{bmatrix}$$

Where X', Y', and Z' are our approximation of the human eye XYZ value. In theory we could use white and make a 3 x 4 matrix, but in practice adding white, which has almost no orthogonality to the RGB space, rarely improves the color correction, while adding additional variability.

With three input colors it is possible to match the CIE outputs at three positions in color space. We can choose those positions as “reference colors”, or we can choose to optimize the RMS error over many color points.

The color correction matrix is calculated from the measured RGB sensor values and reference device XYZ values using a variety of matrix inverse or pseudo-inverse methods. Tikhonov regularization may be used to avoid overfitting where necessary.

One suitable color correction matrix obtained from principal component analysis (PCA) of the sensor spectra is:

$$\begin{bmatrix} 0.366 & 0.126 & 0.0424 \\ 0.0797 & 0.3436 & -0.0375 \\ 0.0582 & -0.1431 & 0.7471 \end{bmatrix}$$

We see that the diagonal terms are the largest terms. This is a good indication that the RGB values are reasonable representations of the XYZ color spectra, and the other colors are providing minor corrections. Figure 7 shows the RGB spectra of the OB1203 and the transformed spectra obtained by combining the spectra in the ratios specified by the color correction matrix. For example, the red channel spectrum is 0.366 of the red plus 0.126 of the green, plus 0.0424 of the blue. The color-corrected red spectrum is wider, the color-corrected green spectrum is more centered on the Y curve and blue spectrum is narrower and centered more towards the shorter wavelength peak of the Z spectrum.

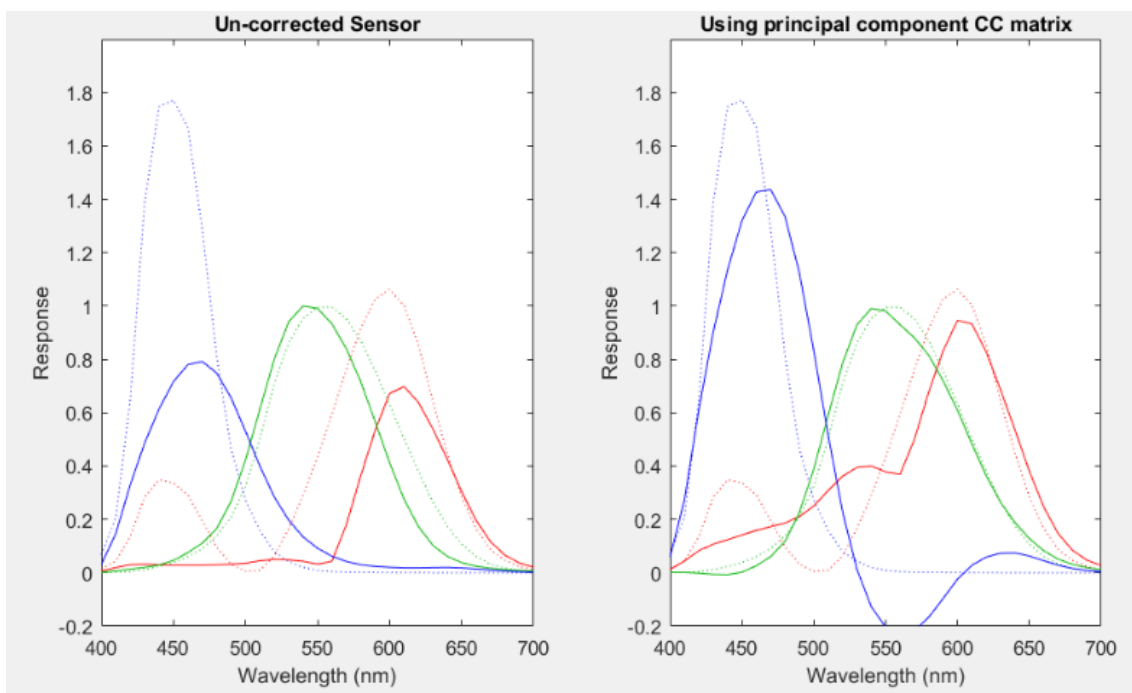

Figure 7. RGB Spectra and Color Corrected Spectra

3.2 Lux Calculation

Since lux is the Y measurement, the coefficients of the lux equation come from the middle row of the color correction matrix.

$$Lux = 0.0797R + 0.3436G - 0.0375B$$

This formula applies to count values in the default gain and resolution settings. Other gain setting will need to be scaled appropriately.

Typically lux accuracy is within $\pm 10\%$.

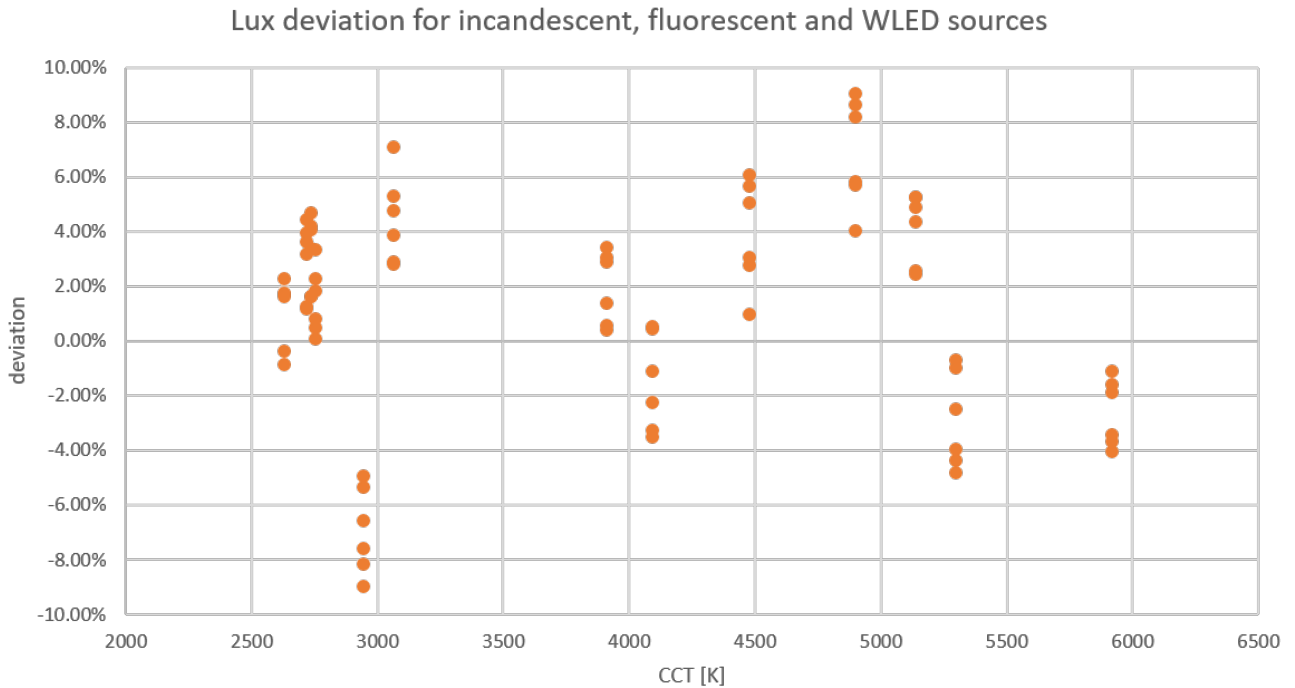

Figure 8. Lux Accuracy for Five OB1203 Devices and 13 Light Sources

3.3 CCT Calculation

Correlated color temperature is the color of an incandescent glowing object that is closest to the observed color. It is the closest distance in uv color space between the Planckian locus—the colors made by hot glowing objects with flat absorption spectra—and the observed color. The Yuv color space represents colors in a conformal map designed so that equal distances are equivalent differences in perceptible color change. In the Yuv color space we can draw a perpendicular line to the Planckian locus to see what temperature object is the nearest color (Figure 8). When we transform the xy color space (Figure 9) those lines are no longer perpendicular but are non-intersecting in a defined region close to the Planckian locus. Beyond that distance, colors are not “white” enough, so they don’t have a correlated color temperature.

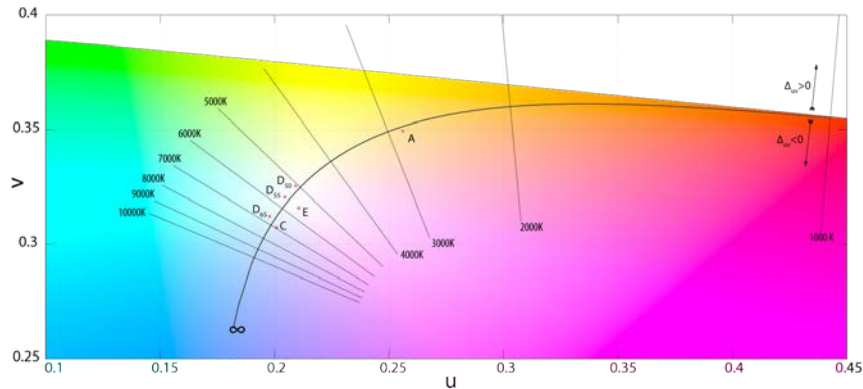

Figure 9. The Planckian Locus and Lines of Equal CCT in the UV Color Space

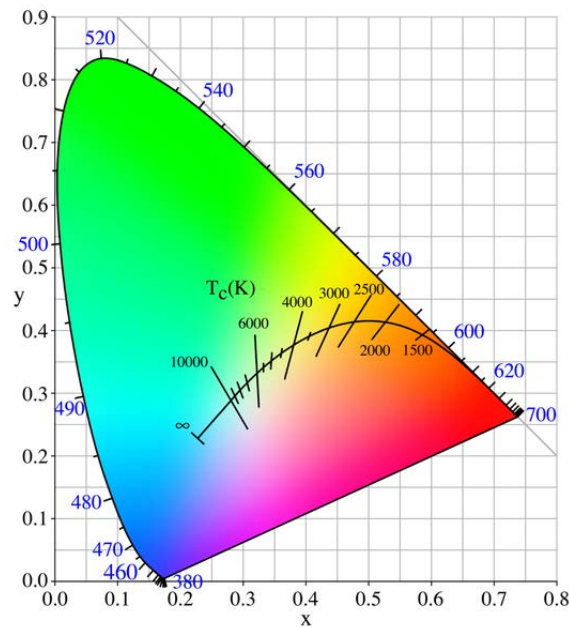

Figure 10. The Planckian Locus and Lines of Equal CCT in XY Color Space

There are many formulas and methods for calculating correlated color temperature (CCT). The full method of converting from xy to uv, finding the nearest distance and converting back is a little processor heavy. Simpler formulas in terms of x and y have been developed including the simple McCamy formula.

The McCamy formula and others are nonlinear formulas which rely on accurate xy color values.

Where CCT accuracy is limited by the color-corrected spectra, it is often more appropriate to generate a heuristic conversion. A linearized model has the advantage of being more robust to color error than nonlinear methods as well as supporting a wide gamut.

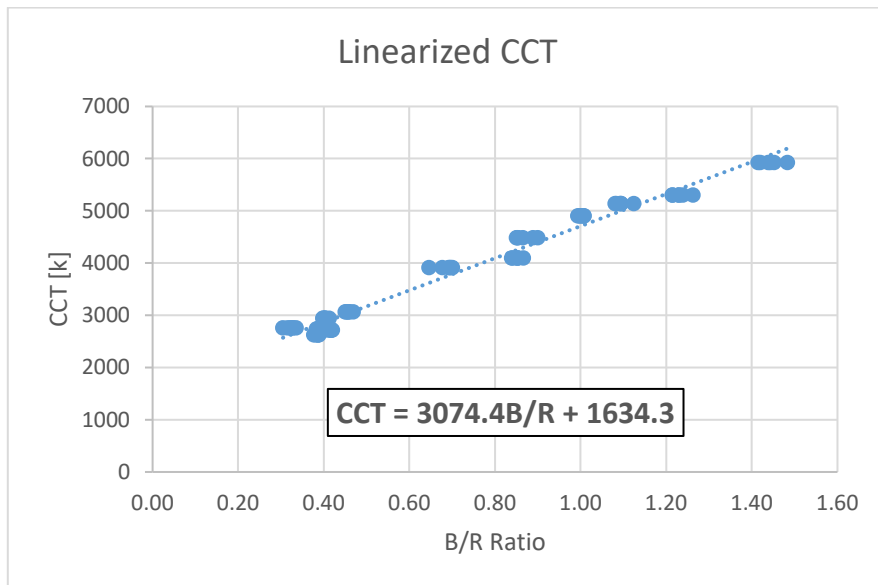

Figure 11. Linearized CCT

For OB1203 the CCT may be calculated as a linear function of the ratio of blue counts to red counts.

$$CCT = 3074.4 \left(\frac{B}{R} \right) + 1634.3$$

Typical CCT accuracy is within ±10%.

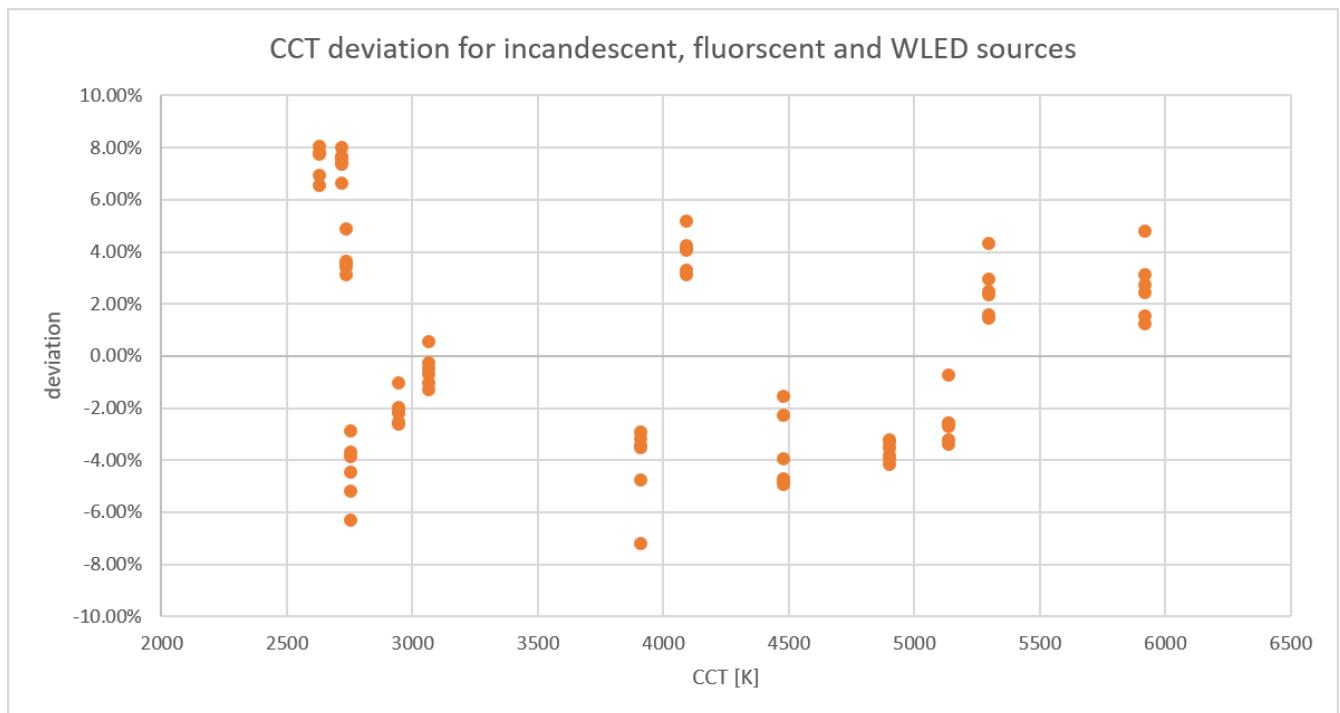

Figure 12. CCT Accuracy for Five OB1203 Devices and 13 Light Sources

4. Revision History

Revision	Date	Description
1.1	Apr.30.20	Redefined document title.
1.0	Apr.20.20	Initial release.

IMPORTANT NOTICE AND DISCLAIMER

RENESAS ELECTRONICS CORPORATION AND ITS SUBSIDIARIES (“RENESAS”) PROVIDES TECHNICAL SPECIFICATIONS AND RELIABILITY DATA (INCLUDING DATASHEETS), DESIGN RESOURCES (INCLUDING REFERENCE DESIGNS), APPLICATION OR OTHER DESIGN ADVICE, WEB TOOLS, SAFETY INFORMATION, AND OTHER RESOURCES “AS IS” AND WITH ALL FAULTS, AND DISCLAIMS ALL WARRANTIES, EXPRESS OR IMPLIED, INCLUDING, WITHOUT LIMITATION, ANY IMPLIED WARRANTIES OF MERCHANTABILITY, FITNESS FOR A PARTICULAR PURPOSE, OR NON-INFRINGEMENT OF THIRD-PARTY INTELLECTUAL PROPERTY RIGHTS.

These resources are intended for developers who are designing with Renesas products. You are solely responsible for (1) selecting the appropriate products for your application, (2) designing, validating, and testing your application, and (3) ensuring your application meets applicable standards, and any other safety, security, or other requirements. These resources are subject to change without notice. Renesas grants you permission to use these resources only to develop an application that uses Renesas products. Other reproduction or use of these resources is strictly prohibited. No license is granted to any other Renesas intellectual property or to any third-party intellectual property. Renesas disclaims responsibility for, and you will fully indemnify Renesas and its representatives against, any claims, damages, costs, losses, or liabilities arising from your use of these resources. Renesas' products are provided only subject to Renesas' Terms and Conditions of Sale or other applicable terms agreed to in writing. No use of any Renesas resources expands or otherwise alters any applicable warranties or warranty disclaimers for these products.

(Disclaimer Rev.1.01)

Corporate Headquarters

TOYOSU FORESIA, 3-2-24 Toyosu,
Koto-ku, Tokyo 135-0061, Japan
www.renesas.com

Trademarks

Renesas and the Renesas logo are trademarks of Renesas Electronics Corporation. All trademarks and registered trademarks are the property of their respective owners.

Contact Information

For further information on a product, technology, the most up-to-date version of a document, or your nearest sales office, please visit www.renesas.com/contact-us/.