

The Charger buck DCDC switching regulator is integrated and designed to power the IDTP95020 device and is an extremely flexible power source that also functions as a Lithium ion or Lithium-polymer battery charger. The Charger is the main power block of the device and it will accept power sources ranging from 4.5 to 5.5V while delivering up to 2A of current to the other DCDC regulators located on the chip. Some of the additional functions integrated and powered by the IDTP95020 charger are the low distortion Audio and Class_D BTL amplifier for driving down to 4Ω speakers, high brightness LED backlight driver illuminating up to 20 LEDs, and a touch screen controller; all powered while charging the portable device's battery, and achieving >87% power efficiency. With all this power and programmability at the users' disposal, care must be taken to get the most out of the Charger block of the IDTP95020. The input power source, typically USB or any other 4.5 to 5.5V power supply is input into the Charger Buck switching regulator operating around 2MHz, which converts the input voltage down to 3.6 to 4.5V. Then using the mask defined internal ROM or the I²C interface, the Charger can be programmed to handle a wide variety of loading configurations. In order to simplify the specified tasks and for convenience, the typical applications will be broken into three categories. The details of these applications and recommended settings will be covered. These applications are not the only available options; however, due to the plethora of programmable variations that the IDTP95020 can be configured into, it is not practical to cover every option.

- Using the Charger to power an entire system using the 8 programmable Low-Drop Out linear regulators, 3 programmable Buck switching regulators, touch screen interface, backlight and audio non-portable solutions.
- Using the Charger to charge a Li⁺ battery, while powering a complete portable or non-portable system.
- Using the Charger when the battery is powering the Charger and the portable system is on the go.

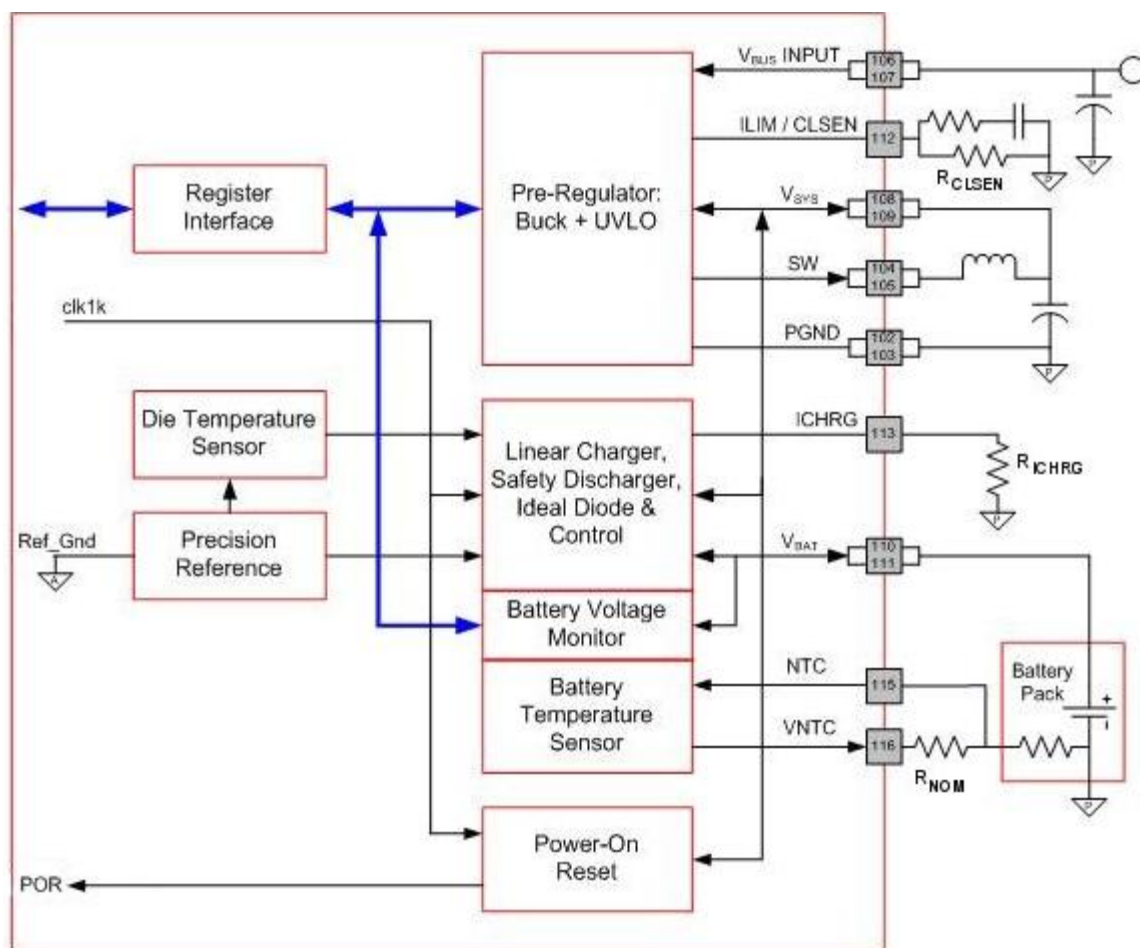

Figure 1 - Charger Block Diagram

When the Charger is powering a complete solution, the programming should be performed by analyzing the necessary loads first. After the deciding the magnitude of all the necessary output voltages and necessary loads on each has been calculated, then the programming of the Charger should be considered. Once the power needed from each output is known, the input requirements can easily be determined using the input current calculator provided by IDT. In this configuration with no battery present, the expected output voltage of the charger will be 3.6V, but this value can be adjusted by placing a series RC connected network to the source of the switch transistor connected to pins CHRG_BAT 1 & 2 (pins A64, B54). After this network has been connected programming the maximum charging voltage, bits 4 & 5 in the Charging Configuration register (Table -1 in Appendix – Registers) will result in system voltage rail (V_{SYS}) being 0.3V greater than the setting programmed into the Charging Configuration Register. Now that the necessary output power and the input voltage is known, the input current limit should be programmed. This is accomplished by programming the programmable input current limit or by programming the current limit to external and using an external

resistor. Using bit 7 of the Current Limit Configuration register (Table -2 in Appendix –Registers) the current limit mode is selected, if programmed to 0, the external resistor connected to CHRG_IGHRG (pin B55) will be used to set the input current limit, and if programmed to 1, then the internal register will control the input current limit. While the internal current limit is being used it will be programmed using bits 0,1, & 2 of the Current Limit Configuration Register in 500mA steps according to Table 8 in section 3.5.1 of the datasheet with the exception being that 100mA is the minimum input current limit setting. When using the external current limit scheme, the input current limit will be controlled by a combination of the R_{CLSEN} resistor resistance and the voltage applied to GPIO4 (pin A72). Setting the GPIO4 pin voltage to V_{SYS} , with $R_{CLSEN} = 600 \Omega$, will result in the highest possible externally programmed current limit value of 1.5A. This current limit can be further limited by changing the R_{CLSEN} resistance according to Fig.2.

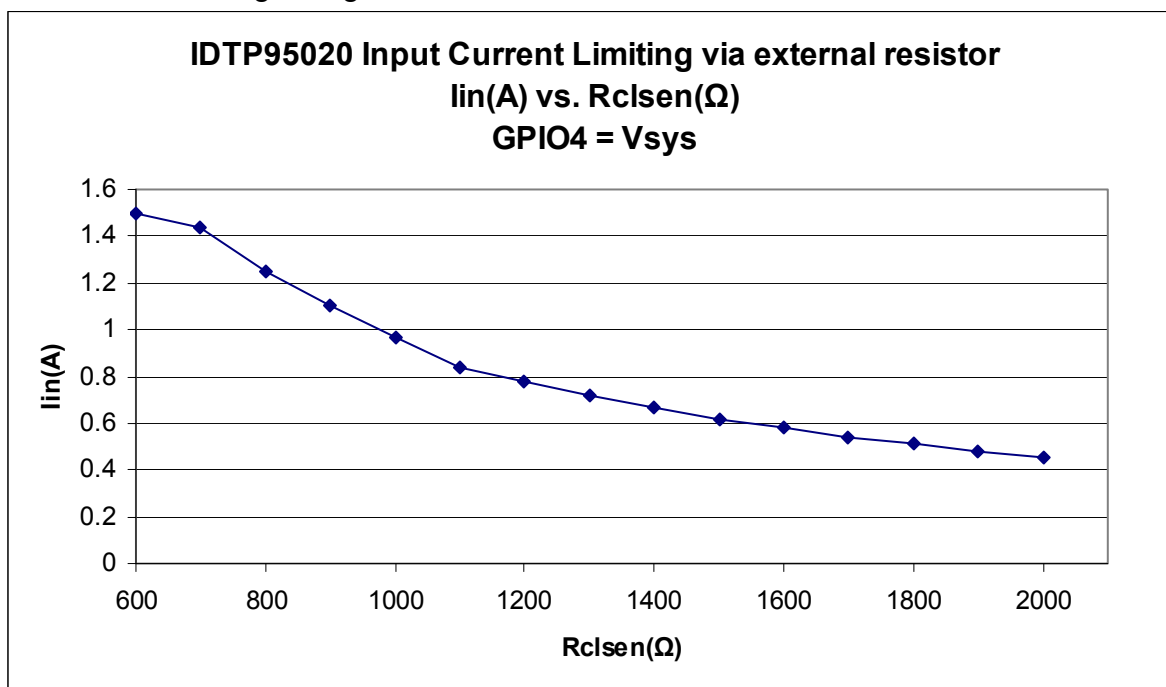

Figure 2 - Typical Input Current Limiting via external resistor, GPIO4= V_{sys}

Alternately forcing the GPIO4 pin voltage to GND(0V), with $R_{CLSEN} = 600 \Omega$ will yield an maximum input current limit of 500mA and changes to R_{CLSEN} will result in current limits defined by Fig.3. Once the input current limit is programmed the rest of the blocks needed by your system are ready to be enabled and programmed to the desired voltage levels in the required activation sequence.

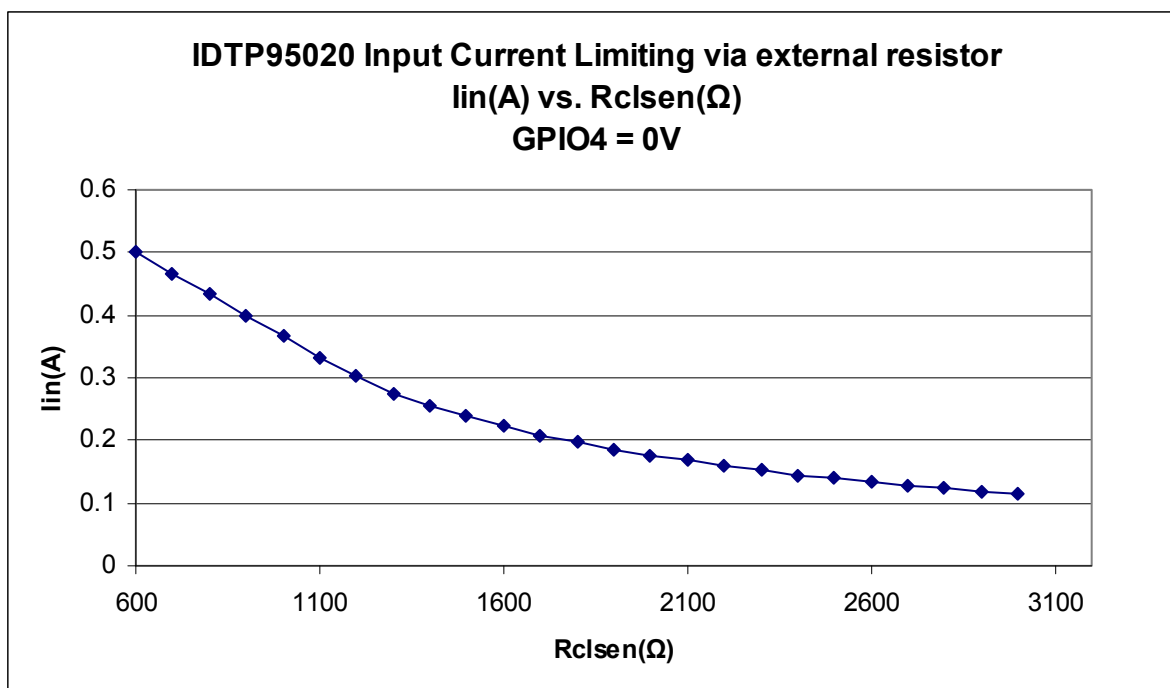

Figure 3 - Typical Input Current Limiting via external resistor, GPIO4=GND

Another useful operating function of the IDTP95020 is to power a complete system while charging or running off of Li^+ batteries. In this mode, aside from the power requirements of the system, additional power resources must be allocated to the battery, and the maximum charging current must be considered when performing the power calculations for the system and the battery. The charge current should be set considering the proper charge current to maximize battery life, which is to charge the battery at full rated load, or in other words if the battery is rated for 3.7Wh, it should be charged at 3.7 volts and 1A. Since this does not correspond to a normal charging curve, the next best situation is to charge the battery to the programmed Charging Maximum Voltage (Table – 1 [5:4] in Appendix –Registers) and setting the Charging Current Limit (Table – 1 [3:0] in Appendix –Registers) to the proportional current. For example, using a 3.7Wh battery, and assuming the maximum charging voltage is 4.1V, the charging current should be programmed to 900mA to target the 3.7Wh rating of the battery to ensure a rapid charge while promoting extended battery lifetime. The dynamic control loop of the charger will supply power to the system load and the programmed charging current as programmed as long the input power limit is not exceeded. However, if the input power limit is exceeded, the Charger will react to this condition in one of two ways:

- Priority is placed on powering the system, thus maintaining the V_{SYS} voltage and routing all of the available current to the system first, then any excess current will be diverted and used for battery charging.

- Priority is placed on charging the battery, thus the programmed current will be directed to charging the battery, and any additional available power will be used to maintain the programmed system voltages.

These are programmed using bit 5 of the Special Control Register (Table – 3 in Appendix – Registers) defined in Section 3.5.5 of the datasheet. When this bit is programmed to 0, the priority is placed on the system first and if the system needs exceed the available power, then the battery will be used to supplement the current shortage and keep the system operating at the programmed voltage levels. If the combination of the battery and the Charger is not providing adequate power for the system, then the expected result is for all of the regulators' voltages to begin falling out proportionally to the shortage of available power. On the flip side of bit 5 of the Special Control Register, programming that bit to a 1, will place the priority on maintaining the programmed battery charging current and in this case any shortage of required current will result in the system voltages falling out proportionally to the system power requirement divided by input power minus the allotted battery charging current. Assuming that the Charger's priority is placed on the system and that there is sufficient power to charge the battery and power the system, several options must be considered for the termination of the charging the battery. Termination of charging will depend upon the time that the sensed battery voltage reaches the programmed Maximum Charging Voltage. For example, at the point in time when the sensed battery voltage equals the programmed Charging Maximum Voltage, the Charger will change from constant current mode to constant voltage mode and the programmed termination mode will be initiated. The programmed charging current will begin to taper off and will cease at the end of the selected charge termination mode. The end of charge (EOC) options can be summarized as follows: Charging will be terminated after a period of time passes by with the time period programmed according to the Table - 11 found in Section 3.5.3 of the datasheet – Charging Termination Control Register (Table – 4 in Appendix –Registers). Charging terminates once the charging current drops below the programmed termination current, or whichever occurs first. Programming the EOC takes place by programming the Charging Termination Control Register. In this register, bits [1:0] program the EOC mode, and the EOC will be controlled in the following manners. Programming [1:0] to 00b will cause the timer bits [6:2] of the same register to count in 2 minute intervals beginning once the programmed termination current (bit [7]) equals the actual charging current and when the programmed time period expires, charging will be complete. Programming [1:0] to 01b will cause the timer bits [6:2] of the same register to count in 10 minute intervals starting the moment the sensed battery voltage equals the programmed Charging Maximum Voltage and when the timer expires, charging will be complete. Programming [1:0] to 10b will cause the charging to be complete the moment the programmed termination current (bit [7]) equals the actual charging current. Finally programming [1:0] to 11b will cause timer bits [6:2] of the same register to count in 10 minute intervals starting the moment the sensed battery voltage equals the programmed Charging Maximum Voltage; additionally, the charging current will be monitored while waiting for the programmed termination current (bit [7]) to equal the actual charging current, and EOC happens when either event occurs. The timer expiring or the charging current reaching the termination current will cause the EOC event in this programmed scenario. Upon the first EOC event

and without an IDTP95020 reset, subsequent charging cycles will follow the same EOC programming (unless changed by user) with the exception that both timers time intervals will be half the time. After the EOC event, the Charger will continuously monitor the battery voltage and if that voltage falls below 3.9V, a charging cycle will be initiated, assuming there is a power source supplied to the Charger.

In the case when the Charger will be powered by only the battery because the input power source is either not present or the voltage is below the minimum operating level (UVLO) the battery will supply all of the system needs. As such the Charger Buck Regulator will not be enabled to save power and the V_{SYS} voltage will be equal to the battery voltage due to the ideal diode transmitting the power from the battery to the system. The Charger charging characteristics should still be set so that when the input source is reconnected, or reaches an adequate voltage level charging will take place in the desired manner. In the event that the battery powers the system until it becomes depleted, the system will shut down at the Battery Good Voltage Threshold (Table – 5 in Appendix –Registers) programmed according to Table-13 in section 3.5.4 of the datasheet and most of the regulators' voltages will already have begun diminishing with the decreasing battery voltage. This shutdown takes place in order to keep the battery from becoming severely depleted. Upon the return of the input power source and dependant upon the voltage level of the battery at the time a few events can occur. If the battery voltage is above the programmed Battery Good Voltage then a normal charge cycle will commence and the system, still operating and enabled according previous programming will continue powering the system normally. If the battery voltage is below the Battery Good Voltage then the Charger will turn on and enter the battery trickle charge mode and the system will be enabled in the programmed power sequence to the previously programmed levels. This trickle charge mode will limit the possible charging current to the current programmed via the Application Settings Register (Table – 5 [7:5] in Appendix –Registers) and defined in Table-12 of Section 3.5.4 of the datasheet. This register will set the charge current whenever the IDTP95020 is reset and the battery voltage is below the Battery Good Voltage. Once the battery voltage exceeds the Battery Good Voltage the programmed charge cycle will commence. Additional safety features that are always applied for all battery charging and usage periods are associated with the Negative Temperature Coefficient thermistor (NTC) which is located within all Li^+ batteries. The way to take advantage of these safety features is to know the room temperature resistance of the thermistor inside the battery that will be charged. Then place a 1% resistor of the same value from the $CHRG_V_{NTC}$ (pin A67) to the $CHRG_NTC$ (pin B55) and additionally tie the $CHRG_NTC$ pin to the NTC node of the battery (R_{NOM}). This will allow the IDTP95020 to continuously monitor the battery temperature and react to drastic changes in battery pack temperature. There are four functions related to these connections based on the battery pack's temperature measured by the temperature dependent resistance of the thermistor. As the battery pack temperature increases the thermistor resistance decreases, and the $CHRG_V_{NTC}$ node will be equal to V_{SYS} , thus when the R_{NOM} and thermistor voltage divider on the $CHRG_NTC$ node is 35% or less of the V_{SYS} voltage, the charger will stop charging because this is an indication that the battery has become too hot and further charging must halt due to damage or possibly hazardous results. Inversely when the battery pack temperature decreases causing the resistance of the thermistor to increase and the voltage at the $CHRG_NTC$ node becomes 76% or greater than the

V_{SYS} voltage, charging will cease because charging a too cold battery can be just as harmful as charging one that is too hot. The third function of these connections is for further safety, which is when the CHRG_NTC node is 20% of the V_{SYS} voltage and the battery voltage is greater than 3.9V, the charger will discharge the battery below 3.9V and no charging will commence until the CHRG_NTC node increases above 35% of the V_{SYS} voltage. This feature discharges fully charged batteries in case they become too hot after being charged to prevent damage. The final possibility is to hard tie the CHRG_NTC node to GND and this will essentially disable the feature and allow for regular charging cycles at all times regardless of battery temperature (this is not recommended in any battery charging application). Another temperature related charging feature of the IDTP95020 is that the Charger will decrease the charging current as the die temperature increases according to the characteristic curves found in Figure-12 of the datasheet.

A few other options worth noting are found in the Special Control Register (Table – 3 in Appendix –Registers) found in Section 3.5.5 of the datasheet. The first is bit 0 which disables the charger and will force the V_{SYS} voltage to be the nominal value of 3.6V which will save power when charging is not necessary. Second is to disable recharging of the battery, which will only allow for one charge cycle provided the IDTP95020 is not reset. This register also allows the disabling of the NTC functions, and the disabling of the constant current, constant voltage charge modes or both. All of these features are designed to save power when their functions are not necessary. Additionally there are two 8-bit status registers and two 8-bit interrupt registers which are crucial for inter-functional communications of each described aspect of the Charger in this note and many others from the IDTP95020 IC to the application processor in the application that the IDTP95020 IC is powering. These registers should be used and taken full advantage of while the IDTP95020 is being designed to power your specific application. If you have any other questions or need any assistance with any programming or options of the IDTP95020 Charger or any other blocks please do not hesitate to contact myself or any other knowledgeable IDT FAE's or Sales Personnel for additional help with your specific application.

Nicholaus W. Smith

Integrated Device Technology, Inc.

APD – Applications Engineering

December 6, 2010

Appendix

Registers-

Charging Configuration Register

I²C Address = Page-0: 145(0x91), μ C Address = 0xA091

Bit	Bit Name	Def. Set.	User Type	Value	Description / Comments
[3:0]	CHG_CUR	0h	RW		Charging Current (via sense resistor) = CHG_CUR x 100 mA
[5:4]	CHG_VOL	00b	RW		Maximum Battery Voltage
[7:6]	RESERVED	00b	RW		RESERVED

Table 1 - Charging Configuration Register

Current Limit Configuration Register

I²C Address = Page-0: 144(0x90), μ C Address = 0xA090

Bit	Bit Name	Def. Set.	User Type	Value	Description / Comments
[2:0]	I_LIM	000b	RW		Current Limit Setting
[6:3]	RESERVED	0h	RW		RESERVED
7	INT_ILIM	1b	RW		Current Limit Source

Table 2 - Current Limit Configuration Register

Special Control Register

I²C Address = Page-0: 148(0x94), μ C Address = 0xA094

Bit	Bit Name	Def. Set.	User Type	Value	Description / Comments
0	DIS_CHARGER	0b	RW	1 = Disable 0 = Enable	Disable Charger
1	DIS_RCH	0b	RW	1 = Disable 0 = Enable	Disable Recharge
2	DIS_NTC	0b	RW	1 = Disable 0 = Enable	Disable NTC-Related Function
3	DIS_CV	0b	RW	1 = Disable 0 = Enable	Disable CV Loop
4	DIS_CC	0b	RW	1 = Disable 0 = Enable	Disable CC Loop
5	DIS_INST_ON	0b	RW	1 = Charging with Priority 0 = System Load with Priority	0: Charging is disabled when V _{sys} is lower than the 3.6V "instant-on" voltage. 1: Reduce charge current when V _{sys} is lower than the 3.6V "instant-on" voltage.
[7:6]	RESERVED	00b	RW		RESERVED

Table 3 - Special Control Register

Registers continued-

Charging Termination Control RegisterI²C Address = Page-0: 146(0x92), μ C Address = 0xA092

Bit	Bit Name	Def. Set.	User Type	Value	Description / Comments
[1:0]	CHG_TERM	00b	RW	(See Error! Reference source not found.)	Charging Termination Time and method after enter CV mode
[6:2]	TERM_TIMER	00001b	RW		CHG_TERM = 00; Termination Timer = TERM_TIMER x 2 minutes CHG_TERM = x1; Termination Timer = TERM_TIMER x 10 minutes
7	TERM_CUR	0b	RW	1 = 100mA 0 = 50mA	Termination Current

Table 4 - Charging Termination Control Register**Application Settings Register**I²C Address = Page-0: 147(0x93), μ C Address = 0xA093

Bit	Bit Name	Def. Set.	User Type	Value	Description / Comments
0	UVLO_VOL	0b	RW	1 = 3.95 V 0 = 4.15 V	Under-Voltage Lockout
[2:1]	RESERVED	00b	RW		RESERVED
[4:3]	BATGD_VOL	11b	RW	(See Error! Reference source not found.)	Battery Good Voltage Threshold, lower than this voltage will be charged with recovery charge method
[7:5]	REC_CHCUR	011b	RW	(See Error! Reference source not found.)	Battery Recovery Charge Current Control

Table 5 - Application Settings Register

IMPORTANT NOTICE AND DISCLAIMER

RENESAS ELECTRONICS CORPORATION AND ITS SUBSIDIARIES (“RENESAS”) PROVIDES TECHNICAL SPECIFICATIONS AND RELIABILITY DATA (INCLUDING DATASHEETS), DESIGN RESOURCES (INCLUDING REFERENCE DESIGNS), APPLICATION OR OTHER DESIGN ADVICE, WEB TOOLS, SAFETY INFORMATION, AND OTHER RESOURCES “AS IS” AND WITH ALL FAULTS, AND DISCLAIMS ALL WARRANTIES, EXPRESS OR IMPLIED, INCLUDING, WITHOUT LIMITATION, ANY IMPLIED WARRANTIES OF MERCHANTABILITY, FITNESS FOR A PARTICULAR PURPOSE, OR NON-INFRINGEMENT OF THIRD-PARTY INTELLECTUAL PROPERTY RIGHTS.

These resources are intended for developers who are designing with Renesas products. You are solely responsible for (1) selecting the appropriate products for your application, (2) designing, validating, and testing your application, and (3) ensuring your application meets applicable standards, and any other safety, security, or other requirements. These resources are subject to change without notice. Renesas grants you permission to use these resources only to develop an application that uses Renesas products. Other reproduction or use of these resources is strictly prohibited. No license is granted to any other Renesas intellectual property or to any third-party intellectual property. Renesas disclaims responsibility for, and you will fully indemnify Renesas and its representatives against, any claims, damages, costs, losses, or liabilities arising from your use of these resources. Renesas' products are provided only subject to Renesas' Terms and Conditions of Sale or other applicable terms agreed to in writing. No use of any Renesas resources expands or otherwise alters any applicable warranties or warranty disclaimers for these products.

(Disclaimer Rev.1.01 Jan 2024)

Corporate Headquarters

TOYOSU FORESIA, 3-2-24 Toyosu,
Koto-ku, Tokyo 135-0061, Japan
www.renesas.com

Trademarks

Renesas and the Renesas logo are trademarks of Renesas Electronics Corporation. All trademarks and registered trademarks are the property of their respective owners.

Contact Information

For further information on a product, technology, the most up-to-date version of a document, or your nearest sales office, please visit www.renesas.com/contact-us/.