

Application Note

Battery Powered Overdrive Pedal for Guitar Effects

AN-CM-279

Abstract

This application note covers the creation of a low voltage low power overdrive pedal using a GreenPAK SLG88104V.

This application note includes a circuit diagram using 3V i.e. two AA batteries, a thorough explanation, diagrams, overview, graph and picture.

EVB versions of GreenPAK operational amplifiers are ready manufactured breakout boards with the operational amplifier on board and soldered. These make it very easy to test designs using through hole methods.

Battery Powered Overdrive Pedal for Guitar Effects

Contents

Abstract	1
Contents	2
Figures	2
1 Terms and Definitions	3
2 References	3
3 Introduction	4
4 Prerequisites	5
4.1 Overview	5
4.2 Explanation and Theory	6
5 Circuit Diagram	9
5.1 Circuit Explained	10
6 Conclusions	11
Revision History	12

Figures

Figure 1: Strong Square Wave Like Clipping, Indicative Example.....	4
Figure 2: Overview Block Diagram of Overdrive Circuit.....	5
Figure 3: Non-inverting Amplifier Topology	6
Figure 4: Non-inverting Amplifier Topology Incorporating Frequency Selective Gain – Dual Version..	7
Figure 5: Graph Demonstrating Hypothetical Frequency Selective Amplification Gain.....	8
Figure 6: Low Voltage, Low Power Overdrive – Circuit Diagram	9
Figure 7: Picture of Prototype as per Circuit Diagram using the SLG88104V-EVB.....	11
Figure 8: 500Hz Scope Display.....	11
Figure 9: 1kHz Scope Display	11

Battery Powered Overdrive Pedal for Guitar Effects

1 Terms and Definitions

Buffer	An amplifier, usually with unity gain, that serves as a protective barrier to preserve current sink/source capabilities
Clipping	A type of wave distortion that occurs when a signal is amplified to the extent such that the wave “clips” or hits the rail lines
Div	Divide
OpAmp	Operational amplifier
Scope	Oscilloscope

2 References

For related documents and software, please visit:

<https://www.dialog-semiconductor.com/products/greenpak>.

Download our free [GreenPAK™ Designer](#) software [1] and use the [GreenPAK development tools](#) [2] to freeze the design into your own customized IC in a matter of minutes. Find out more in complete library of application notes [3] featuring design examples as well as explanations of features and blocks within the GreenPAK IC.

- [1] [GreenPAK Designer Software](#), Software Download and User Guide
- [2] [GreenPAK Development Tools](#), [GreenPAK Development Tools Webpage](#)
- [3] [GreenPAK Application Notes](#), [GreenPAK Application Notes Webpage](#)
- [4] [SLG88104V Datasheet](#)
- [5] [SLG88104V-EVB](#) See [SLG88104V Datasheet](#)

Battery Powered Overdrive Pedal for Guitar Effects

3 Introduction

For the love of music or for the love of electronics, the aim of this application note is to show how critical the SLG88104V Rail to Rail I/O 375nA Quad OpAmp with its low power and low voltage advancements can be to revolutionize overdrive circuits.

Typical overdrive designs on the market today run at 9V. However, as explained here we have been able to achieve an overdrive that is extremely economical in its power usage and running on such a low VDD that it can work using only two AA batteries at three volts for extended periods and extremely long battery life. To further preserve batteries left in the unit, a mechanical switch for disengagement is used as standard. In addition, as the footprint of the SLG88104V is small with minimal amount of batteries used, a small light weight pedal can be made if desired. All of this combined with likeable sound effects makes it a leading overdrive design.

Amplified guitars appeared in the early 1930's. However, at that time early recording artists strove for clean orchestra type sounds. By the 40's DeArmond manufactured the world's first standalone effect. But at that time amplifiers were valve based and bulky. During the 40's and through to the 50's even though clean tones were prevalent, competitive individuals and bands frequently turned their amps volume up to overdrive status and the distortion sound became increasingly popular. In the 60's transistor amplifiers started to be manufactured with the Vox T-60, in 1964 and around the same era to further preserve the distortion sound which was very sought after at that time the first distortion effect was born.

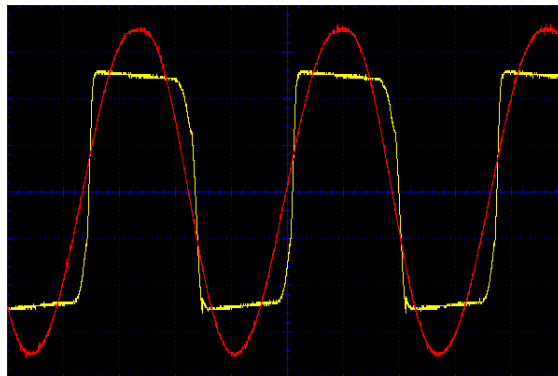

Figure 1: Strong Square Wave Like Clipping, Indicative Example

Battery Powered Overdrive Pedal for Guitar Effects

4 Prerequisites

Analog or digital processing of music signals can provide new effects, and active overdrive effects recreate the overdriven clipping effects of those early valve amps.

Usually unwanted and minimized in terms of amplification the opposite is true in terms of this effect. Clipping produces frequencies that are not present in the original sound and that could have been partly the reason for its appeal in the early days. Strong and almost square wave related clipping produces very hash sounds that are inharmonic to its parent tone, while soft clipping produces harmonic overtones and so generally the sound produced depends on the amount of clipping and depletion with frequency. It's the strong belief of this author that the quality of an overdrive pedal depends on its proportion of harmonic to inharmonic tones throughout its range and its ability to preserve the harmonic tones at higher amplifications.

4.1 Overview

Below is an overview of a proposed circuit, the aim of which is to preserve existing signals and produce those overdrive sounds. Using the SLG88104V allows an Overdrive pedal running on 3 V using two AA batteries which are much more widely available and less expensive to purchase than 9 V PP3 batteries. If desired, AAA batteries can be used instead, although the extra capacity of the AA make it more than apt. Further, the circuit will be able to work on 4.5 V (1.5 V center line +3 V) or 6 V (3 V center line +3 V) if desired, although not necessary.

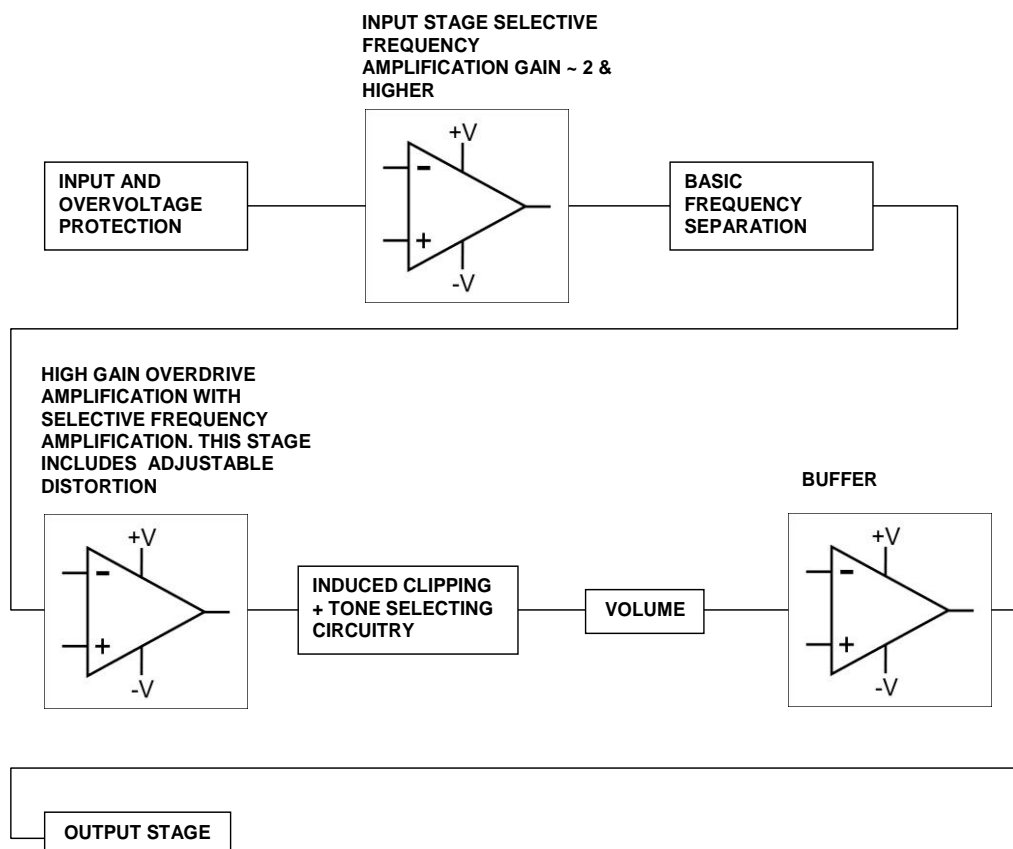

Figure 2: Overview Block Diagram of Overdrive Circuit

Selective frequency amplification - important modification to accomplish amplification at lower voltages.

Battery Powered Overdrive Pedal for Guitar Effects

4.2 Explanation and Theory

We choose to use the non-inverting topology of the amplifier as a base for the gain stages due to its high input impedance and easy adaption for frequency selection.

$$AGain = 1 + \frac{R2}{R1}$$

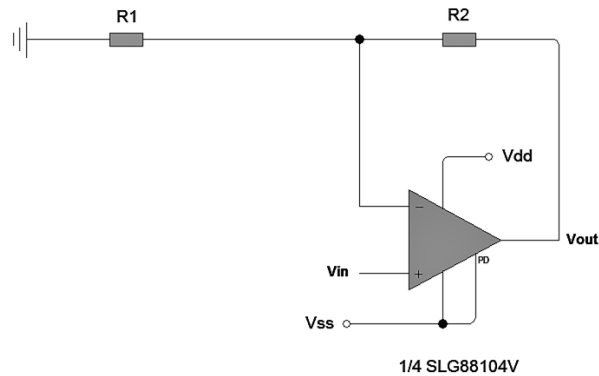

Figure 3: Non-inverting Amplifier Topology

As we have seen, the gain in this set up is solely conditional on the feedback. If we convert this as a high pass topology, gain will be dependent on feedback and input frequencies as per some overdrive arrangements. Further, if the filter feedback circuitry is doubled, then the topology will apply one range of responsive gains to the input and then a further different set of responsive gains.

This setup can serve to both clarify the design and allow a more frequency directional / selective amplification. Below is the diagram of such arrangement with formulas producing interesting conclusions. This topology is an important crux relied upon by the final overdrive circuitry which will incorporate it as a main core several times to maintain a working model.

If we look at things a little simpler, then for a certain frequency f

$$AGain = 1 + \frac{2\pi f C1 R2}{2\pi f C1 R1 + 1}$$

and

$$AGain = 1 + \frac{2\pi f C1 R2}{2\pi f C2 R3 + 1}$$

Battery Powered Overdrive Pedal for Guitar Effects

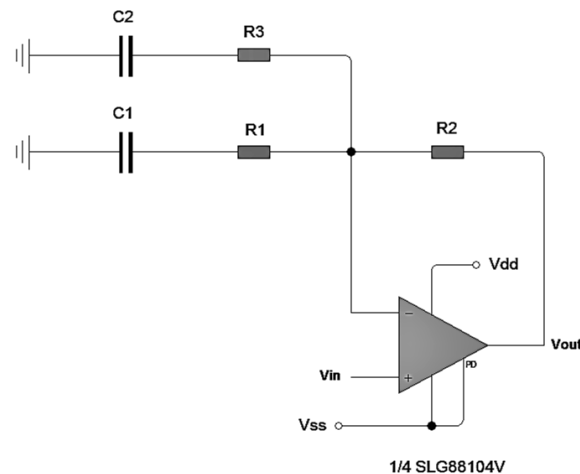

Figure 4: Non-inverting Amplifier Topology Incorporating Frequency Selective Gain – Dual Version

The actual equation for AGain at a particular frequency f is thus:

$$AGain = 1 + \frac{R1R2 + R3R2 + \left(\frac{R2}{2\pi f C1}\right) + \left(\frac{R2}{2\pi f C2}\right)}{\left(R1 + \frac{1}{2\pi f C1}\right) \left(R3 + \left(\frac{1}{2\pi f C2}\right)\right)}$$

which breaks down further to produce a final formula:

$$AGain = 1 + \frac{2\pi f C1 R1}{2\pi f C1 R1 + 1} + \frac{2\pi f C2 R2}{2\pi f C2 R3 + 1}$$

As evident this is analogous to the addition of the simplified equations above except for the inherent unity gain of the amplifier which is constant. In summary the frequency response gain of each high pass feedback topology leg is compounded.

The aim of such arrangements is to obtain a more uniform amplification of the input signal over the frequency range so that at higher frequencies where the OpAmp's gain is reduced, we can introduce more gain. At low voltages the sound can be preserved through those low frequencies even though the headroom is not very high.

Battery Powered Overdrive Pedal for Guitar Effects

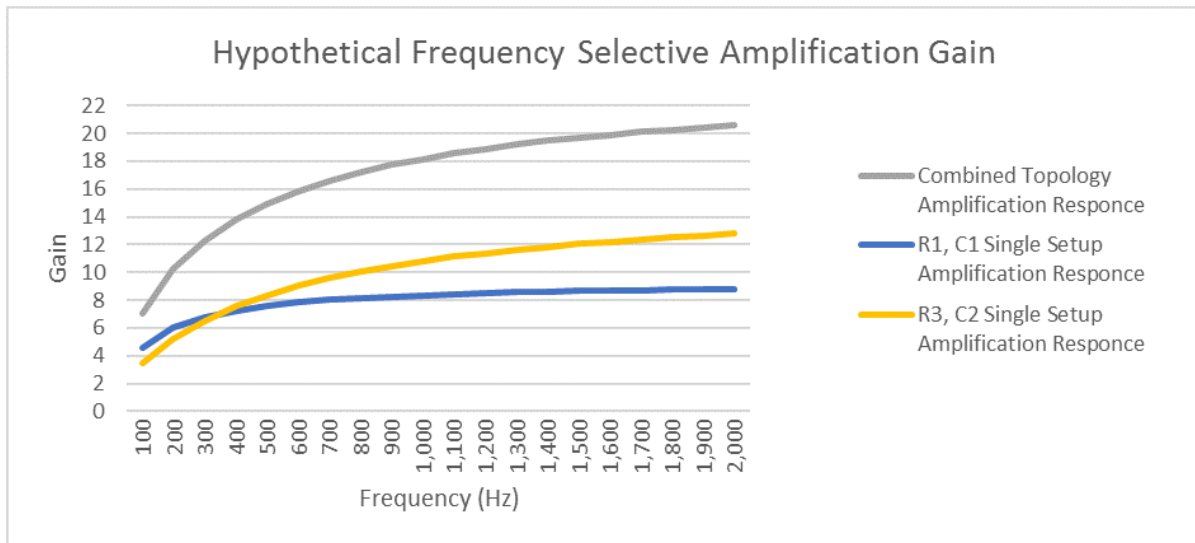

Figure 5: Graph Demonstrating Hypothetical Frequency Selective Amplification Gain

Battery Powered Overdrive Pedal for Guitar Effects

5 Circuit Diagram

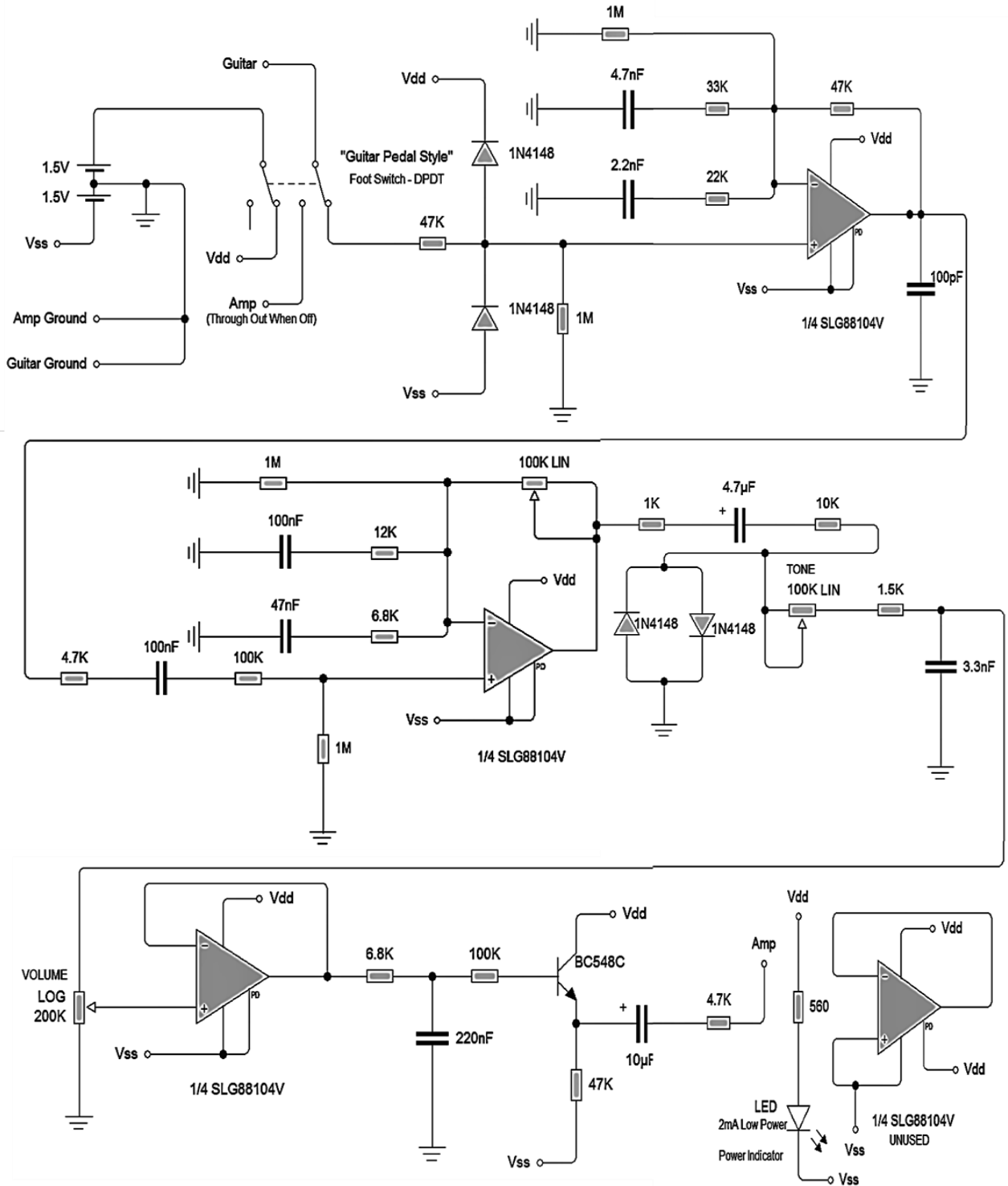

Figure 6: Low Voltage, Low Power Overdrive – Circuit Diagram

Battery Powered Overdrive Pedal for Guitar Effects

5.1 Circuit Explained

The SLG88103/4V incorporates innate input protection to prevent overvoltage at its inputs. Extra protection diodes have been added at the initial stage of overdrive input for extra design robustness.

First stage amplification acts as a first stage high impedance buffer and amplifies initially to prepare for the overdrive stage. Gain is around two although it varies with frequency. At this stage care needs to be taken to ensure that the amplification stays low, as any amplification at this stage is multiplied into the overdrive amplification.

Following through to the overdrive stage, where the signal will undergo large gains, frequency selective amplification again ensures that the higher frequencies get that boost for a more consistent amplification, and consecutively we induce clipping using two diodes in forward conductive mode. A simple low pass filter forms the tone, and this leads to a simple volume potentiometer and a buffer to drive the output.

Only three of the on-board Operational Amplifiers are utilized, and the last remaining one is wired appropriately as per “proper setup for unused OpAmps”. If desired, 2 x SLG88103V'S can be used instead of the single SLG88104V.

A low power light emitting diode indicates an on-state. The importance of it being a low power version cannot be understated due to the low quiescent currents and running power of the SLG88104V. The main power consumption from the circuit will be the power indicator LED.

In fact, due to the extremely low 375 nA quiescent current, the power consideration for the [GreenPAK](#) SLG88104V is very small. The majority of power loss is through the decoupling low pass capacitors and the emitter follower resistor. If we measure the current consumption of the complete circuit's quiescent current, it turns out to be only about 20 μ A, increasing to around a maximum of 90 μ A when the guitar is in action. This is very small compared to the 2 mA consumed by the LED and is the reason that the use of a low power LED is imperative. We can estimate the average life of a single AA alkaline battery to drain from full to 1 V is around 2000 mAh* at a discharge rate of 100 mA. A decent new pair of batteries producing 3 V should then be able to source over 4000 mAh. With the LED in place our circuit measures a 1.75 mA draw from which we can estimate over 2285 hours or 95 days of continuous usage. Because overdrives are active circuits our overdrive can produce “a hell of a kick” at minimal current usage. As a side note, two AAA batteries should last around half the time of the AA.

Below is the working model of this overdrive circuit. Obviously, as with any pedal, the user needs to adjust the settings to find the sound that is most apt for them. Turning the amp's mid and bass higher than treble seemed to give really cool overdrive sounds for us (as treble was harsher). It then resembled the warmer old-fashioned type of sound.

Because of the [GreenPAK](#) SLG88104V's tiny package and very low power consumption, we have succeeded in achieving a low power overdrive pedal that is less bulky and runs on only two pencil type batteries for a great length of time.

AA batteries are more readily available, and there is the possibility that they will not be changed for the life of any working unit, making it extremely easy maintenance and ecologically friendly. Further, it can be built with a small number of external components, so it can be low cost, easy to make, and as stated previously, lightweight.

* Source: Energizer E91 Datasheet (see bar graph), powerstream.com

Battery Powered Overdrive Pedal for Guitar Effects

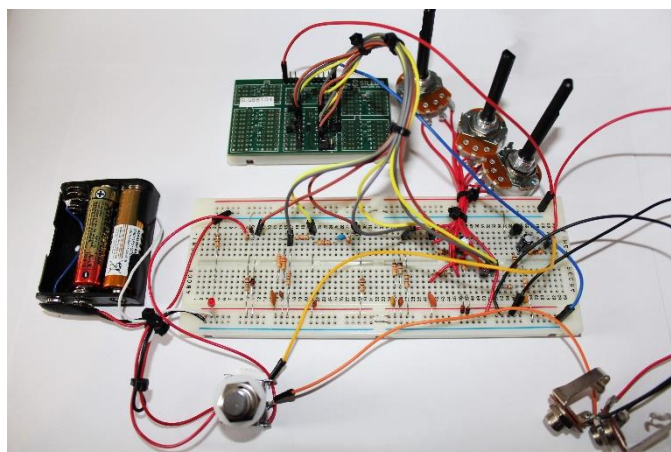

Figure 7: Picture of Prototype as per Circuit Diagram using the SLG88104V-EVB

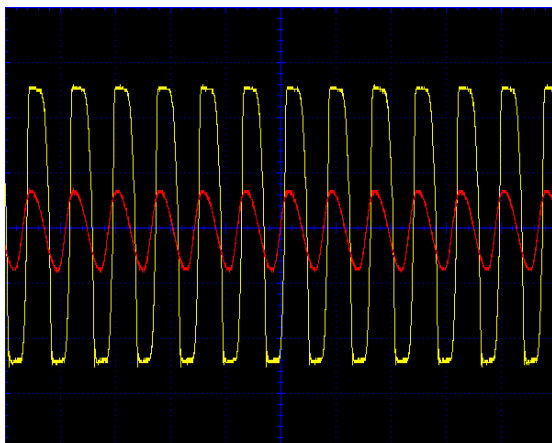

Figure 8: 500Hz Scope Display

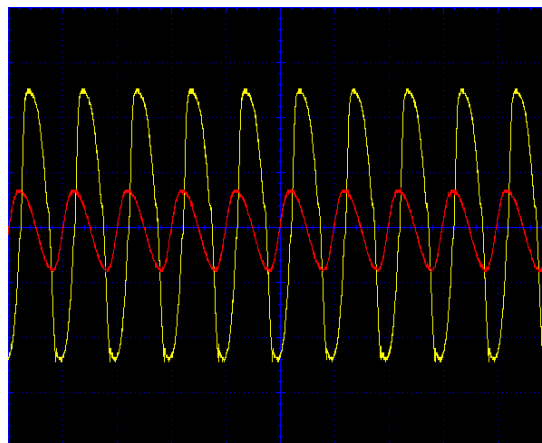

Figure 9: 1kHz Scope Display

Figure 8: Ch1 Red, Ch2 Yellow. Ch1 Overdrive Input, Sine Wave, 304 Vpk-pk, 513 Hz. 200 mV/Div, Timebase 2.5 mS. Ch2 Overdrive Buffer Output, Clipped Sine Wave, 1.024 Vpk-pk 513 Hz. 200 mV/Div, Timebase 2.5 mS

Figure 9: Ch1 Red, Ch2 Yellow. Ch1 Overdrive Input, Sine Wave, 304 Vpk-pk, 1 kHz. 200 mV/Div, Timebase 1 mS. Ch2 Overdrive Buffer Output, Clipped Sine Wave, 992 mVpk-pk 1 kHz. 200 mV/Div, Timebase 1 mS

6 Conclusions

In this application note we have constructed a low voltage low power overdrive pedal.

Aside from handling the analog processing for GreenPAK's mixed-signal IC's and other digital semiconductors, GreenPAK's Rail to Rail Low Voltage, Low Current OpAmp's have been shown to be useful in overdrive circuitry. They are autonomous in many other applications and especially advantageous in power sensitive applications.

Battery Powered Overdrive Pedal for Guitar Effects**Revision History**

Revision	Date	Description
1.0	12-Sep-2018	Initial Version

IMPORTANT NOTICE AND DISCLAIMER

RENESAS ELECTRONICS CORPORATION AND ITS SUBSIDIARIES (“RENESAS”) PROVIDES TECHNICAL SPECIFICATIONS AND RELIABILITY DATA (INCLUDING DATASHEETS), DESIGN RESOURCES (INCLUDING REFERENCE DESIGNS), APPLICATION OR OTHER DESIGN ADVICE, WEB TOOLS, SAFETY INFORMATION, AND OTHER RESOURCES “AS IS” AND WITH ALL FAULTS, AND DISCLAIMS ALL WARRANTIES, EXPRESS OR IMPLIED, INCLUDING, WITHOUT LIMITATION, ANY IMPLIED WARRANTIES OF MERCHANTABILITY, FITNESS FOR A PARTICULAR PURPOSE, OR NON-INFRINGEMENT OF THIRD-PARTY INTELLECTUAL PROPERTY RIGHTS.

These resources are intended for developers who are designing with Renesas products. You are solely responsible for (1) selecting the appropriate products for your application, (2) designing, validating, and testing your application, and (3) ensuring your application meets applicable standards, and any other safety, security, or other requirements. These resources are subject to change without notice. Renesas grants you permission to use these resources only to develop an application that uses Renesas products. Other reproduction or use of these resources is strictly prohibited. No license is granted to any other Renesas intellectual property or to any third-party intellectual property. Renesas disclaims responsibility for, and you will fully indemnify Renesas and its representatives against, any claims, damages, costs, losses, or liabilities arising from your use of these resources. Renesas' products are provided only subject to Renesas' Terms and Conditions of Sale or other applicable terms agreed to in writing. No use of any Renesas resources expands or otherwise alters any applicable warranties or warranty disclaimers for these products.

(Disclaimer Rev.1.01)

Corporate Headquarters

TOYOSU FORESIA, 3-2-24 Toyosu,
Koto-ku, Tokyo 135-0061, Japan
www.renesas.com

Trademarks

Renesas and the Renesas logo are trademarks of Renesas Electronics Corporation. All trademarks and registered trademarks are the property of their respective owners.

Contact Information

For further information on a product, technology, the most up-to-date version of a document, or your nearest sales office, please visit www.renesas.com/contact-us/.