

How to Use HSP43168 to Implement Complex Filtering

The architecture of the HSP43168 allows for filtering of complex inputs. The output of the filtering operation in the complex case will calculate an Imaginary (I) and a Real (R) component. The complex filter outputs are governed by the following equations.

$$Y_R(n) = \sum_{j=0}^{N-1} X_R(j)C_R(j) - X_I(j)C_I(j)$$

and:

$$Y_I(n) = \sum_{j=0}^{N-1} X_R(j)C_I(j) + X_I(j)C_R(j)$$

Where: Y_R = Real Output Component
 Y_I = Imaginary Output Component
 X_R, X_I = I and R Input Components
 C_R = Real Coefficients
 C_I = Imaginary Coefficients

Using a single HSP43168 dual FIR Filter one can implement a 4-tap complex filter with the output rate running at the full input rate. The HSP43168 architecture includes two independent FIR filters that can be configured to operate in various modes. For this example the two filters within the HSP43168 are configured to operate as two separate filters, FIR A and FIR B. FIR A is calculating the Real Output $Y_R(n)$, while FIR B is calculating the Imaginary Output $Y_I(n)$.

Figure 1 illustrates a top level Block Diagram for the complex filtering operations of the HSP43168. Each of the two filters FIR A and FIR B must be programmed to decimate by 2. This implies that every 2 clocks the real and imaginary outputs are calculated and then loaded into the holding registers. The contents of these registers are then multiplexed and clocked out at the full input rate.

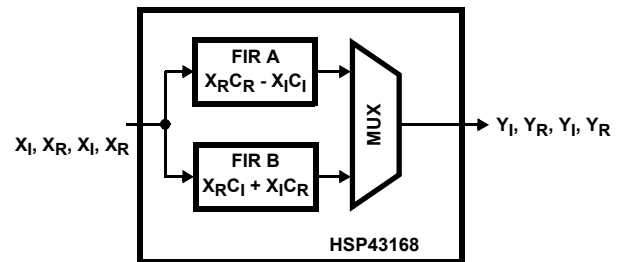

FIGURE 1. HSP43168 SINGLE CHIP CONFIGURATION TO PERFORM COMPLEX FILTERING

Figure 2 illustrates in more detail the internal operations of the HSP43168 as it calculates Y_R and Y_I .

The computational flow for FIR A is:

$$\text{Clock 1: } X_R(0) \cdot C_R(3) + X_R(1) \cdot C_R(2) + X_R(2) \cdot C_R(1) + X_R(3) \cdot C_R(0)$$

$$\text{Clock 2: } X_R(0) \cdot C_R(3) + X_R(1) \cdot C_R(2) + X_R(2) \cdot C_R(1) + X_R(3) \cdot C_R(0) \\ + \\ -X_I(0) \cdot C_I(3) - X_I(1) \cdot C_I(2) - X_I(2) \cdot C_I(1) - X_I(3) \cdot C_I(0)$$

Similarly, the computational flow for FIR B is:

$$\text{Clock 1: } X_R(0) \cdot C_I(3) + X_R(1) \cdot C_I(2) + X_R(2) \cdot C_I(1) + X_R(3) \cdot C_I(0)$$

$$\text{Clock 2: } X_R(0) \cdot C_I(3) + X_R(1) \cdot C_I(2) + X_R(2) \cdot C_I(1) + X_R(3) \cdot C_I(0) \\ + \\ X_I(0) \cdot C_R(3) + X_I(1) \cdot C_R(2) + X_I(2) \cdot C_R(1) + X_I(3) \cdot C_R(0)$$

After Clock 2, both Y_R and Y_I are valid and ready to be multiplexed as outputs. Note on Figure 2 that in the decimate by 2 mode, there are two decimation registers between each multiplier. This ensures that either all R or all I input samples are aligned at the multipliers on alternate clocks. Also note that a different coefficient set is used on alternate clocks. Real coefficients and imaginary coefficients are alternated on every clock as appropriate for each of the two filters to calculate the desired results.

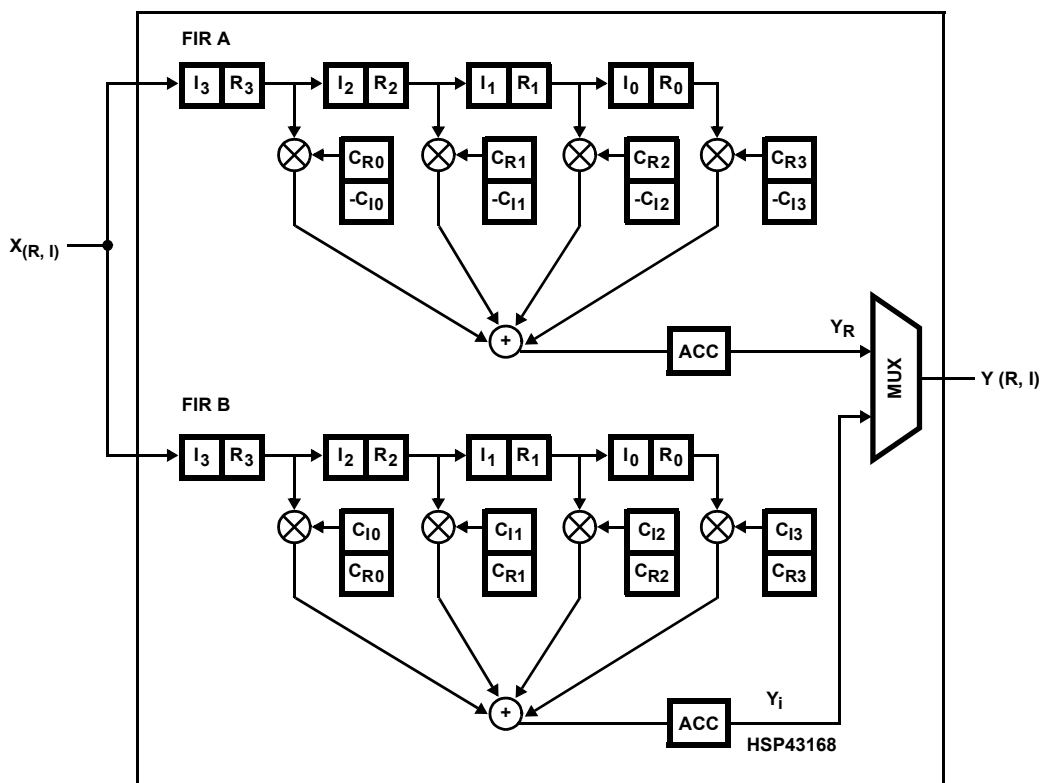

FIGURE 2. DATA FLOW WITHIN HSP43168 CONFIGURED AS A COMPLEX FILTER

Combining Multiple HSP43168 Filters For Extended Number of Taps and Complex Filtering

Many applications require more than 4-taps to achieve the filtering requirements of the system.

Multiple HSP43168s can be combined to meet these requirements. One possible architecture that implements complex filtering for extended number of taps is shown on Figure 3. This example illustrates the implementation of a 16-tap complex filter using the HSP43168 as the core filtering engine. This example also assumes that the desired output rate of the filter is equal to the input rate of the data. The example can be expanded to accommodate more taps and/or various input and output data rates. The maximum number of filters that can be combined together under this architecture is limited by the maximum decimation factor of the HSP43168. The maximum throughput is set by the maximum data rate that a single HSP43168 can operate at.

As shown on Figure 3, there are eight HSP43168 filters that are required for this 16-tap implementation. The architecture is partitioned into two processing groups with one group of 4 filters calculating the real output component and the second group of 4 filters calculating the imaginary output component of the complex result.

The two independent FIR filters that are integrated in each of the 8 HSP43168 devices are configured to operate as separate filters. Each FIRA is processing the real input samples $X(\text{real})$ while each FIRB is processing the imaginary input samples

$X(\text{im.})$. In addition, each of the individual filters is set in a decimate by four mode. In essence, this decimating factor is actually increasing the number of taps from four to sixteen for each of the individual FIR operations.

Decimation causes each of the filters to have an output rate that is four times less than the input rate (decimation by 4). For this example the input data rate is 45MHz and the decimated output rate of each filter is 11.25MHz.

In an attempt to better understand the signal processing throughout this architecture, the calculation of the real output component will be described in some detail. The hardware processing for the calculation of the imaginary complex output is equivalent.

The combined output for the group of the four filters, that calculates the real output component, runs at the aggregate rate of its 4 filters, which is the 45MHz input rate (11.25×4). This implies that the output MUX selects one of the four individual filters at every 45MHz clock, rotating sequentially through the output of each of the four filters. Every filter calculates the sum of products that defines the real output component which is defined by the following equation:

$$Y_R(n) = \sum_{j=0}^{N-1} X_R(j)C_R(j) - X_I(j)C_I(j)$$

where: Y_R = Real Output Component
 X_R, X_I = I and R Input Components
 C_R = Real Coefficients
 C_I = Imaginary Coefficients

and $N = 16$ representing the 16 filter taps required for this example.

Since each of the four filter outputs is selected sequentially every fourth consecutive clock, all of the input data samples are being filtered within the filter combination. The four filters are programmed to use all 16 coefficients in the decimate by four mode.

Figure 4 illustrates the data flow and register structure within a single HSP43168 device. The snapshot shows 16 real and 16 imaginary input samples loaded in the registers. Note that in the decimate by 4 mode there are 4 registers between each of the 4 multipliers for FIRA and FIRB.

The sum of the 16 products required for each output sample is calculated over four clocks by shifting four new samples and their corresponding coefficients at the inputs of the four multipliers as shown on the Diagram of Figure 4. The results of FIRA and FIRB are accumulated individually and they are finally combined every fourth clock to provide the desired output sample. The computational flow for FIRA over the 4 clock periods is shown below as an example for the calculation of the sum of products processing. The example illustrates the results in the accumulator for each of the clocks.

Clock 1: $R(0) C(3) + R(4) C(2) + R(8) C(1) + R(12) C(0)$
 Clock 2: $R(0) C(3) + R(4) C(2) + R(8) C(1) + R(12) C(0) + R(1) C(7) + R(5) C(6) + R(9) C(5) + R(13) C(4)$
 Clock 3: $R(0) C(3) + R(4) C(2) + R(8) C(1) + R(12) C(0) + R(1) C(7) + R(5) C(6) + R(9) C(5) + R(13) C(4) + R(2) C(11) + R(6) C(10) + R(10) C(9) + R(14) C(8)$
 Clock 4: $R(0) C(3) + R(4) C(2) + R(8) C(1) + R(12) C(0) + R(1) C(7) + R(5) C(6) + R(9) C(5) + R(13) C(4) + R(2) C(11) + R(6) C(10) + R(10) C(9) + R(14) C(8) + R(3) C(15) + R(7) C(14) + R(11) C(13) + R(15) C(12)$

Therefore, FIRA calculates one of the two partial sum of products that is necessary for the real complex output component. This partial sum of products is:

$$\left(\begin{array}{c} N-1 \\ \sum \\ j=0 \end{array} X_R(j) C_R(j) \right)$$

In a similar fashion FIRB calculates the second partial sum of the overall real output sample which is:

$$\left(\begin{array}{c} N-1 \\ \sum \\ j=0 \end{array} X_I(j) C_I(j) \right)$$

The results of the two filters are finally combined as shown on Figure 4 in order to produce the desired output sample. Note that there are 4 filters in the group running in parallel but with their outputs staggered by one clock. This architecture assures the processing of all input samples.

The implementation for the calculation of the imaginary component of the complex output is identical to that of the real and is performed by the lower group of the other 4 HSP43168s as shown on Figure 3. This second group of filters calculates the imaginary component equation:

$$Y_I(n) = \sum_{j=0}^{N-1} X_R(j) C_I(j) + X_I(j) C_R(j)$$

Where: Y_I = Imaginary Output Samples
 X_R, X_I = R and I Input Samples
 C_R = Real Coefficients
 C_I = Imaginary Coefficients

The Timing Diagram that describes the relationship between data, control signals and clocks to operate a single HSP43168 at its decimating mode is shown on Figure 5. The Timing Diagrams on Figure 5 are examples for the decimate by 2 and decimate by 4 cases. Timing of the device for higher decimation factors can be readily derived based on these two sample examples. For more details on signal description and part functionality and operation refer to the Intersil DSP Data Book.

The examples described in this Application Note provide the core architectural and signal processing details that can be followed to implement other complex filters with different length and/or data rate requirements.

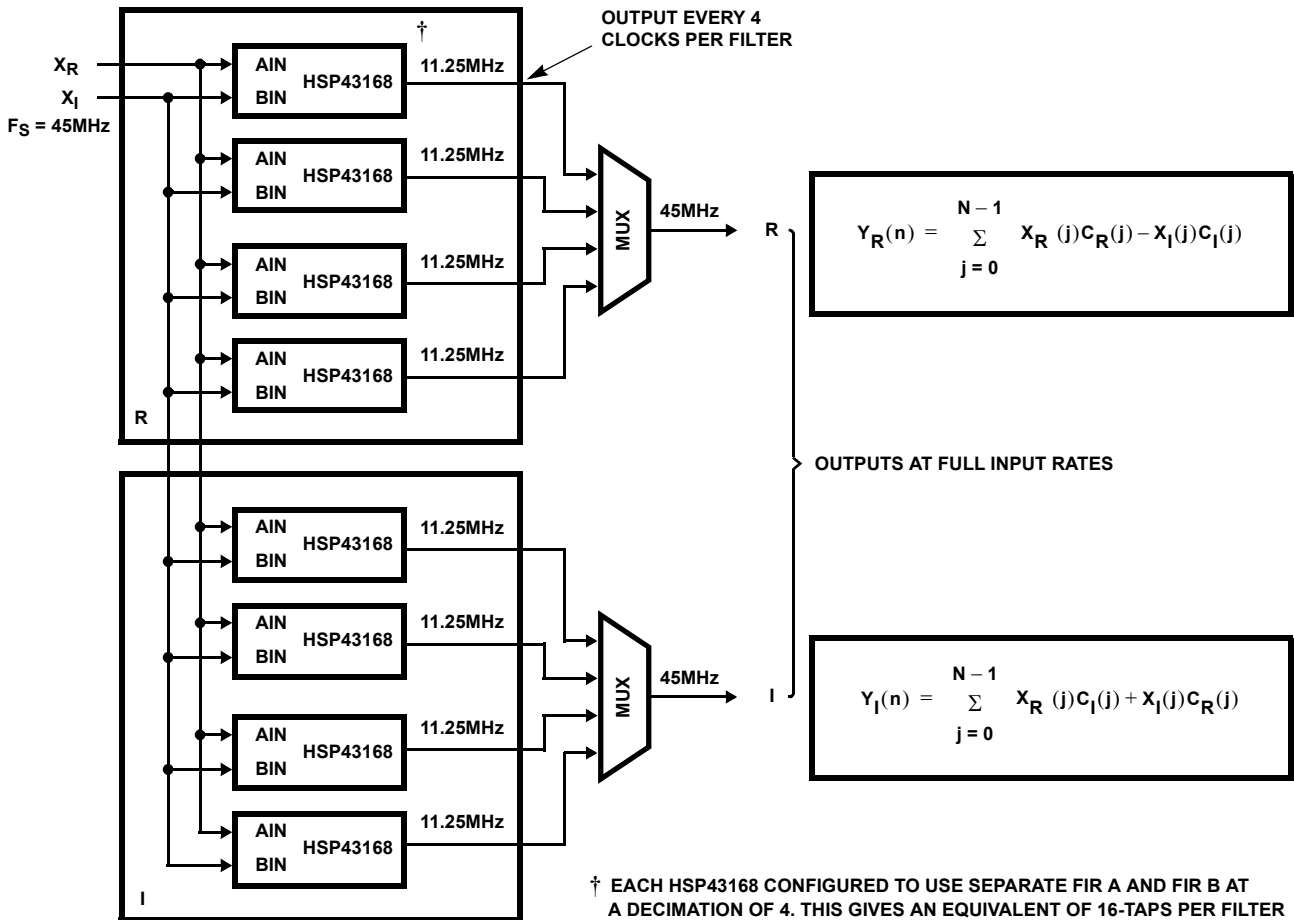

FIGURE 3. 16-TAP COMPLEX FILTER AT 45MHz

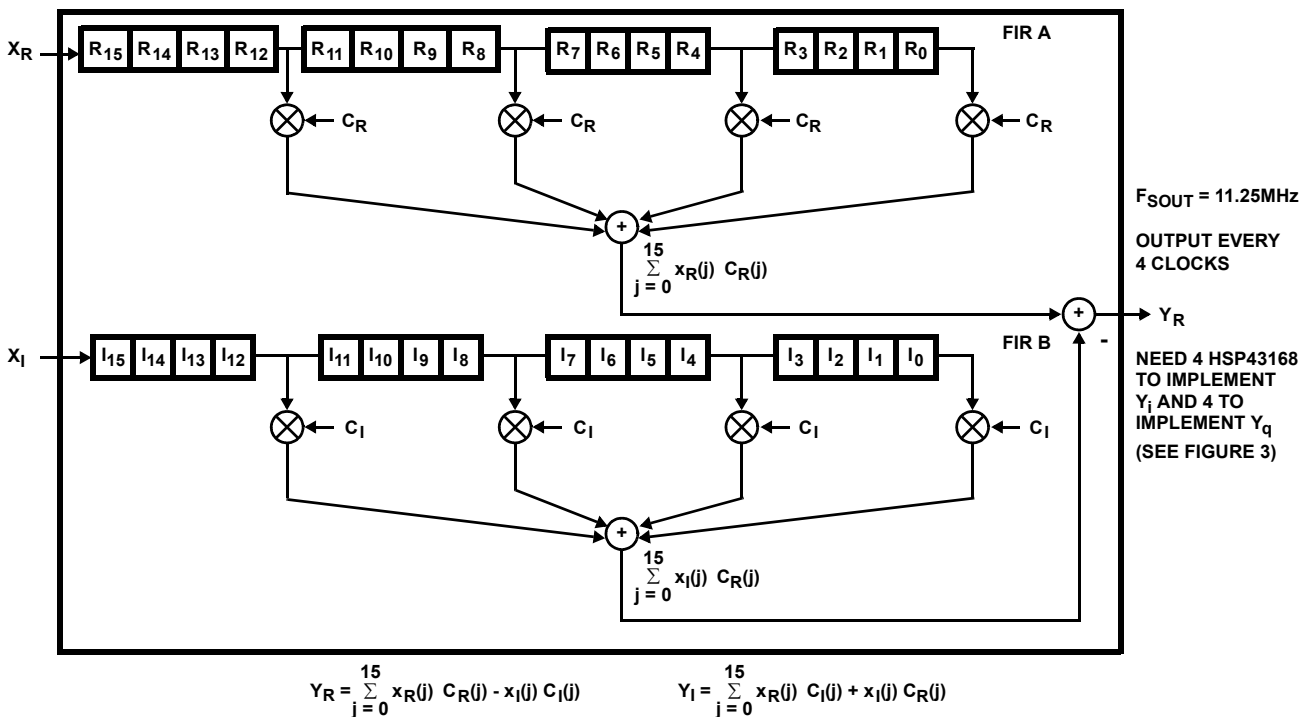

FIGURE 4. INTERNAL OPERATIONS PER FILTER (Y_R EXAMPLE)

Timing Diagram

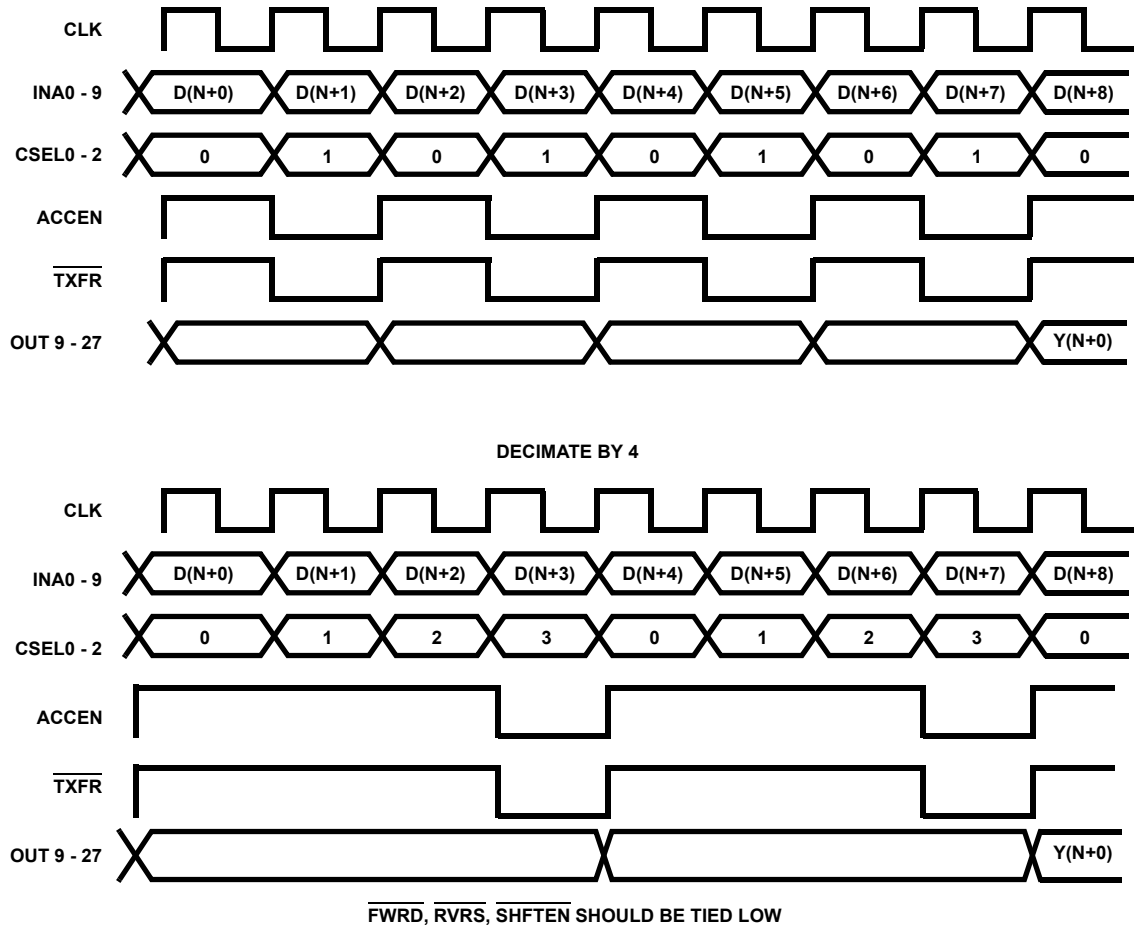

FIGURE 5. TIMING DIAGRAM OF DECIMATING MODES

Notice

1. Descriptions of circuits, software and other related information in this document are provided only to illustrate the operation of semiconductor products and application examples. You are fully responsible for the incorporation or any other use of the circuits, software, and information in the design of your product or system. Renesas Electronics disclaims any and all liability for any losses and damages incurred by you or third parties arising from the use of these circuits, software, or information.
2. Renesas Electronics hereby expressly disclaims any warranties against and liability for infringement or any other claims involving patents, copyrights, or other intellectual property rights of third parties, by or arising from the use of Renesas Electronics products or technical information described in this document, including but not limited to, the product data, drawings, charts, programs, algorithms, and application examples.
3. No license, express, implied or otherwise, is granted hereby under any patents, copyrights or other intellectual property rights of Renesas Electronics or others.
4. You shall not alter, modify, copy, or reverse engineer any Renesas Electronics product, whether in whole or in part. Renesas Electronics disclaims any and all liability for any losses or damages incurred by you or third parties arising from such alteration, modification, copying or reverse engineering.
5. Renesas Electronics products are classified according to the following two quality grades: "Standard" and "High Quality". The intended applications for each Renesas Electronics product depends on the product's quality grade, as indicated below.
"Standard": Computers; office equipment; communications equipment; test and measurement equipment; audio and visual equipment; home electronic appliances; machine tools; personal electronic equipment; industrial robots; etc.
"High Quality": Transportation equipment (automobiles, trains, ships, etc.); traffic control (traffic lights); large-scale communication equipment; key financial terminal systems; safety control equipment; etc.
Unless expressly designated as a high reliability product or a product for harsh environments in a Renesas Electronics data sheet or other Renesas Electronics document, Renesas Electronics products are not intended or authorized for use in products or systems that may pose a direct threat to human life or bodily injury (artificial life support devices or systems; surgical implantations; etc.), or may cause serious property damage (space system; undersea repeaters; nuclear power control systems; aircraft control systems; key plant systems; military equipment; etc.). Renesas Electronics disclaims any and all liability for any damages or losses incurred by you or any third parties arising from the use of any Renesas Electronics product that is inconsistent with any Renesas Electronics data sheet, user's manual or other Renesas Electronics document.
6. When using Renesas Electronics products, refer to the latest product information (data sheets, user's manuals, application notes, "General Notes for Handling and Using Semiconductor Devices" in the reliability handbook, etc.), and ensure that usage conditions are within the ranges specified by Renesas Electronics with respect to maximum ratings, operating power supply voltage range, heat dissipation characteristics, installation, etc. Renesas Electronics disclaims any and all liability for any malfunctions, failure or accident arising out of the use of Renesas Electronics products outside of such specified ranges.
7. Although Renesas Electronics endeavors to improve the quality and reliability of Renesas Electronics products, semiconductor products have specific characteristics, such as the occurrence of failure at a certain rate and malfunctions under certain use conditions. Unless designated as a high reliability product or a product for harsh environments in a Renesas Electronics data sheet or other Renesas Electronics document, Renesas Electronics products are not subject to radiation resistance design. You are responsible for implementing safety measures to guard against the possibility of bodily injury, injury or damage caused by fire, and/or danger to the public in the event of a failure or malfunction of Renesas Electronics products, such as safety design for hardware and software, including but not limited to redundancy, fire control and malfunction prevention, appropriate treatment for aging degradation or any other appropriate measures. Because the evaluation of microcomputer software alone is very difficult and impractical, you are responsible for evaluating the safety of the final products or systems manufactured by you.
8. Please contact a Renesas Electronics sales office for details as to environmental matters such as the environmental compatibility of each Renesas Electronics product. You are responsible for carefully and sufficiently investigating applicable laws and regulations that regulate the inclusion or use of controlled substances, including without limitation, the EU RoHS Directive, and using Renesas Electronics products in compliance with all these applicable laws and regulations. Renesas Electronics disclaims any and all liability for damages or losses occurring as a result of your noncompliance with applicable laws and regulations.
9. Renesas Electronics products and technologies shall not be used for or incorporated into any products or systems whose manufacture, use, or sale is prohibited under any applicable domestic or foreign laws or regulations. You shall comply with any applicable export control laws and regulations promulgated and administered by the governments of any countries asserting jurisdiction over the parties or transactions.
10. It is the responsibility of the buyer or distributor of Renesas Electronics products, or any other party who distributes, disposes of, or otherwise sells or transfers the product to a third party, to notify such third party in advance of the contents and conditions set forth in this document.
11. This document shall not be reprinted, reproduced or duplicated in any form, in whole or in part, without prior written consent of Renesas Electronics.
12. Please contact a Renesas Electronics sales office if you have any questions regarding the information contained in this document or Renesas Electronics products.
(Note 1) "Renesas Electronics" as used in this document means Renesas Electronics Corporation and also includes its directly or indirectly controlled subsidiaries.
(Note 2) "Renesas Electronics product(s)" means any product developed or manufactured by or for Renesas Electronics.

(Rev.4.0-1 November 2017)



SALES OFFICES

Renesas Electronics Corporation

<http://www.renesas.com>

Refer to "<http://www.renesas.com/>" for the latest and detailed information.

Renesas Electronics America Inc.
1001 Murphy Ranch Road, Milpitas, CA 95035, U.S.A.
Tel: +1-408-432-8888, Fax: +1-408-434-5351

Renesas Electronics Canada Limited
9251 Yonge Street, Suite 8309 Richmond Hill, Ontario Canada L4C 9T3
Tel: +1-905-237-2004

Renesas Electronics Europe Limited
Dukes Meadow, Millboard Road, Bourne End, Buckinghamshire, SL8 5FH, U.K
Tel: +44-1628-651-700, Fax: +44-1628-651-804

Renesas Electronics Europe GmbH
Arcadiastrasse 10, 40472 Düsseldorf, Germany
Tel: +49-211-6503-0, Fax: +49-211-6503-1327

Renesas Electronics (China) Co., Ltd.
Room 1709 Quantum Plaza, No.27 ZhichunLu, Haidian District, Beijing, 100191 P. R. China
Tel: +86-10-8235-1155, Fax: +86-10-8235-7679

Renesas Electronics (Shanghai) Co., Ltd.
Unit 301, Tower A, Central Towers, 555 Langao Road, Putuo District, Shanghai, 200333 P. R. China
Tel: +86-21-2226-0888, Fax: +86-21-2226-0999

Renesas Electronics Hong Kong Limited
Unit 1601-1611, 16/F., Tower 2, Grand Century Place, 193 Prince Edward Road West, Mongkok, Kowloon, Hong Kong
Tel: +852-2265-6688, Fax: +852-2886-9022

Renesas Electronics Taiwan Co., Ltd.
13F, No. 363, Fu Shing North Road, Taipei 10543, Taiwan
Tel: +886-2-8175-9600, Fax: +886-2-8175-9670

Renesas Electronics Singapore Pte. Ltd.
80 Bendemeer Road, Unit #06-02 Hyflux Innovation Centre, Singapore 339949
Tel: +65-6213-0200, Fax: +65-6213-0300

Renesas Electronics Malaysia Sdn.Bhd.
Unit 1207, Block B, Menara Amcorp, Amcorp Trade Centre, No. 18, Jln Persiaran Barat, 46050 Petaling Jaya, Selangor Darul Ehsan, Malaysia
Tel: +60-3-7955-9390, Fax: +60-3-7955-9510

Renesas Electronics India Pvt. Ltd.
No.777C, 100 Feet Road, HAL 2nd Stage, Indiranagar, Bangalore 560 038, India
Tel: +91-80-67208700, Fax: +91-80-67208777

Renesas Electronics Korea Co., Ltd.
17F, KAMCO Yangjae Tower, 262, Gangnam-daero, Gangnam-gu, Seoul, 06265 Korea
Tel: +82-2-558-3737, Fax: +82-2-558-5338