

Introduction

This application note describes a unique implementation for the Intersil X9241 Digitally Controlled Potentiometers (XDCPs) in a process control or process monitoring environment. This implementation is made possible by some of the features of X9241, many of which have not been available on XDCP devices prior to the introduction of the X9241.

Implementation

Imagine a process control system or any other system where an analog voltage from a transducer needs to be monitored. The ideal method of monitoring such signals is to have an "alarm" in place for when the signal drifts out of its acceptable operating range, and to have the absolute value of the signal accessible to the processor so that intelligent decisions can be made about how to address the new condition. There are several ways of accomplishing this task using A-to-D converters, resistor-divider networks, or similar techniques, but these solutions prove to be messy and/or costly.

Imagine achieving the requirements of the ideal monitor with nothing more than a potentiometer and a comparator! The potentiometer is used to set a reference voltage which will become the trip point at which an "alarm" is generated (Figure 1). A simple comparator is used to compare the reference voltage to a transducer output voltage. The comparator output is then used to signal the processor by means of an interrupt. The missing element is the means to read the value of the transducer voltage. This can be done by implementing an A-to-D converter, but this adds cost and complexity. A variable voltage reference is still required, which the A-to-D converter cannot provide. By using the X9241 quad XDCP as the precision reference voltage potentiometer, the transducer voltage can be determined without adding any other components.

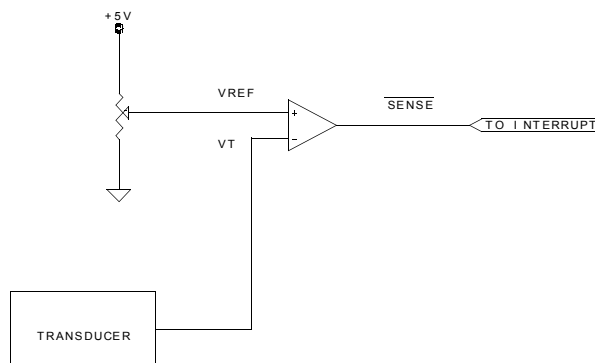

FIGURE 1.

The key to this scheme is a feature of the X9241 that allows direct reading of the contents of the Wiper Counter Registers (WCRs). Each of the four potentiometers on the X9241 has a WCR which contains the numeric position of the corresponding wiper. The processor can read the digital contents of the WCR via a 2-wire serial communications bus and, if necessary, easily calculate the actual wiper voltage. By adjusting the X9241 and reading the I/O bit assigned to the comparator output (after first disabling the interrupt), the XDCPs wiper voltage is matched to the transducer voltage, which can be determined by reading the contents of the WCR (Figure 2). The reference wiper setting (or the trip point setting) is not lost since it had previously been stored in one of the XDCPs four nonvolatile data registers (R0-R3). The contents of the desired data register can be transferred into the WCR by giving the appropriate software command. The interrupt is then enabled to resume monitoring.

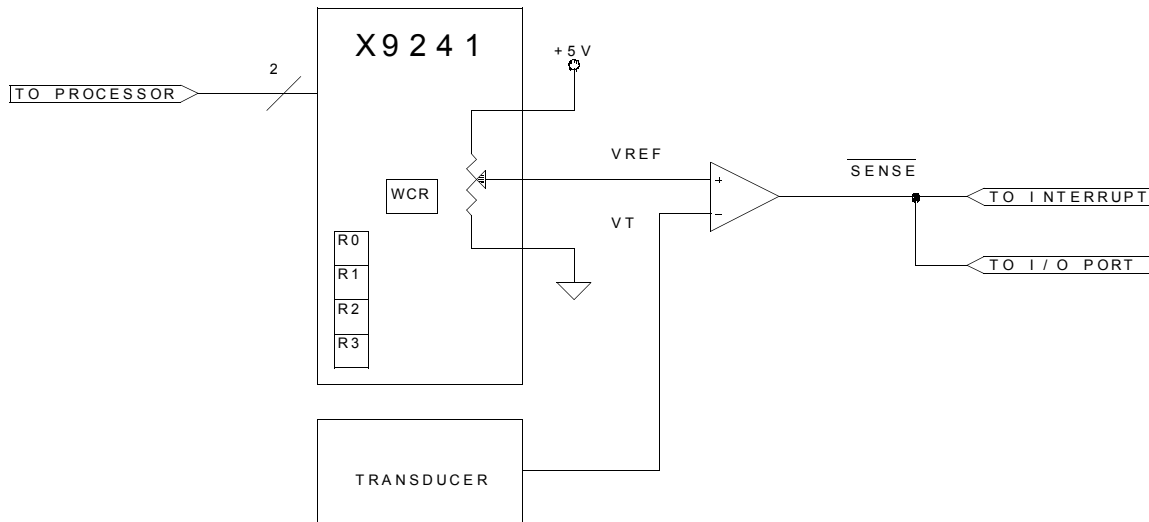

FIGURE 2. SMART MONITOR USING X9241 QUAD XDCP

System Calibration

Calibration of the transducer and A-to-D conversion process can be easily achieved by storing the required constants in system memory and having the system processor perform the appropriate calculation. In this manner the total system is calibrated rather than calibrating the transducer and A-to-D converter individually.

Reference Voltage Resolution

The X9241 consists of four potentiometers with 63 resistive elements each, giving each potentiometer 64 steps or wiper positions. The resolution would thus be 1/63 or approximately 1.59%. The X9241 feature set includes a cascade mode where adjacent potentiometers can be connected in series, and the extra wipers disabled, resulting in potentiometers of 127, 190, or 253 steps with internal wiper transitions, allowing resolution levels of 0.79%, 0.53%, or 0.40% respectively. If higher resolution is required, vernier cascading techniques can be used. (For a method of increasing resolution, see Intersil application note AN43 "Software Implements a High Resolution Nonvolatile Digital Potentiometer".)

Application Example

Let's say that a liquid or chemical used in a process must be at least +65°C for the process to yield the desired results. The reference voltage is initially calibrated by adjusting the XDCP, so that its wiper voltage is the next increment below the actual voltage of the transducer at +65°C. The WCR contents are then stored into the desired E2 register, (R0-R3.) If the temperature of the liquid drops below +65°C, the comparator changes state and an interrupt is generated. The processor can then adjust the potentiometer until the comparator output changes state again, at which point the WCR contents can be

read to find the new transducer voltage level. The processor can then make a decision about what has happened. If the temperature had drifted a couple of degrees below +65°C, then warming heaters can be switched on (or intensity increased) to return the liquid to +65°C. The process can then continue uninterrupted and the event can be logged into the system's EEPROM or NOVRAM memory for future analysis. However, if the voltage read indicates a temperature dramatically below +65°C, then the process can be shut down and the appropriate "alarm" activated. This monitor can easily be set-up to maintain an operating window, for example +65°C ±1°C, by using dual comparators.

Conclusion

The advanced features of the X9241, especially the direct read capability of the WCRs, allow the user to simplify monitor controls by having a device that functions both as a variable reference voltage and an A-to-D converter. Additionally, the X9241 allows total system calibration since correction factors may be stored in system memory and combined with the contents of the WCR as required for calibration. The 128-bits of nonvolatile memory in the data registers may be used for other purposes, if all four data registers are not required for use in transducer monitoring. The X9241 thus offers the user a simple, low cost, yet quite versatile solution for intelligent process monitoring and control.

Notice

1. Descriptions of circuits, software and other related information in this document are provided only to illustrate the operation of semiconductor products and application examples. You are fully responsible for the incorporation or any other use of the circuits, software, and information in the design of your product or system. Renesas Electronics disclaims any and all liability for any losses and damages incurred by you or third parties arising from the use of these circuits, software, or information.
2. Renesas Electronics hereby expressly disclaims any warranties against and liability for infringement or any other claims involving patents, copyrights, or other intellectual property rights of third parties, by or arising from the use of Renesas Electronics products or technical information described in this document, including but not limited to, the product data, drawings, charts, programs, algorithms, and application examples.
3. No license, express, implied or otherwise, is granted hereby under any patents, copyrights or other intellectual property rights of Renesas Electronics or others.
4. You shall not alter, modify, copy, or reverse engineer any Renesas Electronics product, whether in whole or in part. Renesas Electronics disclaims any and all liability for any losses or damages incurred by you or third parties arising from such alteration, modification, copying or reverse engineering.
5. Renesas Electronics products are classified according to the following two quality grades: "Standard" and "High Quality". The intended applications for each Renesas Electronics product depends on the product's quality grade, as indicated below.
"Standard": Computers; office equipment; communications equipment; test and measurement equipment; audio and visual equipment; home electronic appliances; machine tools; personal electronic equipment; industrial robots; etc.
"High Quality": Transportation equipment (automobiles, trains, ships, etc.); traffic control (traffic lights); large-scale communication equipment; key financial terminal systems; safety control equipment; etc.
Unless expressly designated as a high reliability product or a product for harsh environments in a Renesas Electronics data sheet or other Renesas Electronics document, Renesas Electronics products are not intended or authorized for use in products or systems that may pose a direct threat to human life or bodily injury (artificial life support devices or systems; surgical implantations; etc.), or may cause serious property damage (space system; undersea repeaters; nuclear power control systems; aircraft control systems; key plant systems; military equipment; etc.). Renesas Electronics disclaims any and all liability for any damages or losses incurred by you or any third parties arising from the use of any Renesas Electronics product that is inconsistent with any Renesas Electronics data sheet, user's manual or other Renesas Electronics document.
6. When using Renesas Electronics products, refer to the latest product information (data sheets, user's manuals, application notes, "General Notes for Handling and Using Semiconductor Devices" in the reliability handbook, etc.), and ensure that usage conditions are within the ranges specified by Renesas Electronics with respect to maximum ratings, operating power supply voltage range, heat dissipation characteristics, installation, etc. Renesas Electronics disclaims any and all liability for any malfunctions, failure or accident arising out of the use of Renesas Electronics products outside of such specified ranges.
7. Although Renesas Electronics endeavors to improve the quality and reliability of Renesas Electronics products, semiconductor products have specific characteristics, such as the occurrence of failure at a certain rate and malfunctions under certain use conditions. Unless designated as a high reliability product or a product for harsh environments in a Renesas Electronics data sheet or other Renesas Electronics document, Renesas Electronics products are not subject to radiation resistance design. You are responsible for implementing safety measures to guard against the possibility of bodily injury, injury or damage caused by fire, and/or danger to the public in the event of a failure or malfunction of Renesas Electronics products, such as safety design for hardware and software, including but not limited to redundancy, fire control and malfunction prevention, appropriate treatment for aging degradation or any other appropriate measures. Because the evaluation of microcomputer software alone is very difficult and impractical, you are responsible for evaluating the safety of the final products or systems manufactured by you.
8. Please contact a Renesas Electronics sales office for details as to environmental matters such as the environmental compatibility of each Renesas Electronics product. You are responsible for carefully and sufficiently investigating applicable laws and regulations that regulate the inclusion or use of controlled substances, including without limitation, the EU RoHS Directive, and using Renesas Electronics products in compliance with all these applicable laws and regulations. Renesas Electronics disclaims any and all liability for damages or losses occurring as a result of your noncompliance with applicable laws and regulations.
9. Renesas Electronics products and technologies shall not be used for or incorporated into any products or systems whose manufacture, use, or sale is prohibited under any applicable domestic or foreign laws or regulations. You shall comply with any applicable export control laws and regulations promulgated and administered by the governments of any countries asserting jurisdiction over the parties or transactions.
10. It is the responsibility of the buyer or distributor of Renesas Electronics products, or any other party who distributes, disposes of, or otherwise sells or transfers the product to a third party, to notify such third party in advance of the contents and conditions set forth in this document.
11. This document shall not be reprinted, reproduced or duplicated in any form, in whole or in part, without prior written consent of Renesas Electronics.
12. Please contact a Renesas Electronics sales office if you have any questions regarding the information contained in this document or Renesas Electronics products.
(Note 1) "Renesas Electronics" as used in this document means Renesas Electronics Corporation and also includes its directly or indirectly controlled subsidiaries.
(Note 2) "Renesas Electronics product(s)" means any product developed or manufactured by or for Renesas Electronics.

(Rev.4.0-1 November 2017)



SALES OFFICES

Renesas Electronics Corporation

<http://www.renesas.com>

Refer to "<http://www.renesas.com/>" for the latest and detailed information.

Renesas Electronics America Inc.
1001 Murphy Ranch Road, Milpitas, CA 95035, U.S.A.
Tel: +1-408-432-8888, Fax: +1-408-434-5351

Renesas Electronics Canada Limited
9251 Yonge Street, Suite 8309 Richmond Hill, Ontario Canada L4C 9T3
Tel: +1-905-237-2004

Renesas Electronics Europe Limited
Dukes Meadow, Millboard Road, Bourne End, Buckinghamshire, SL8 5FH, U.K
Tel: +44-1628-651-700, Fax: +44-1628-651-804

Renesas Electronics Europe GmbH
Arcadiastrasse 10, 40472 Düsseldorf, Germany
Tel: +49-211-6503-0, Fax: +49-211-6503-1327

Renesas Electronics (China) Co., Ltd.
Room 1709 Quantum Plaza, No.27 ZhichunLu, Haidian District, Beijing, 100191 P. R. China
Tel: +86-10-8235-1155, Fax: +86-10-8235-7679

Renesas Electronics (Shanghai) Co., Ltd.
Unit 301, Tower A, Central Towers, 555 Langao Road, Putuo District, Shanghai, 200333 P. R. China
Tel: +86-21-2226-0888, Fax: +86-21-2226-0999

Renesas Electronics Hong Kong Limited
Unit 1601-1611, 16/F., Tower 2, Grand Century Place, 193 Prince Edward Road West, Mongkok, Kowloon, Hong Kong
Tel: +852-2265-6688, Fax: +852-2886-9022

Renesas Electronics Taiwan Co., Ltd.
13F, No. 363, Fu Shing North Road, Taipei 10543, Taiwan
Tel: +886-2-8175-9600, Fax: +886-2-8175-9670

Renesas Electronics Singapore Pte. Ltd.
80 Bendemeer Road, Unit #06-02 Hyflux Innovation Centre, Singapore 339949
Tel: +65-6213-0200, Fax: +65-6213-0300

Renesas Electronics Malaysia Sdn.Bhd.
Unit 1207, Block B, Menara Amcorp, Amcorp Trade Centre, No. 18, Jln Persiaran Barat, 46050 Petaling Jaya, Selangor Darul Ehsan, Malaysia
Tel: +60-3-7955-9390, Fax: +60-3-7955-9510

Renesas Electronics India Pvt. Ltd.
No.777C, 100 Feet Road, HAL 2nd Stage, Indiranagar, Bangalore 560 038, India
Tel: +91-80-67208700, Fax: +91-80-67208777

Renesas Electronics Korea Co., Ltd.
17F, KAMCO Yangjae Tower, 262, Gangnam-daero, Gangnam-gu, Seoul, 06265 Korea
Tel: +82-2-558-3737, Fax: +82-2-558-5338