

Introduction

The process of powering up a part like the X9258 can be challenging. There are up to five different supply voltages connected to the part. Because of the protection mechanisms built into the device there is a lot of flexibility in how the supplies power-up. However, not all possible power supply conditions can be handled internally.

The power supply issue is complicated further, because as the various voltages are applied to the part, initial conditions are being recalled from internal registers. These recalled values set the wiper position and initialize of the serial interface circuit.

There are two main failure conditions that result from improper power on sequencing. These are:

1. Damage to the device due to latchup caused by reverse voltage application.
2. Improper Power On Recall (POR) of initial conditions.

This document explores the failure mechanisms and recommends conditions for consistent device operation.

Power Supply Limits

The following conditions are specified in the data sheet and MUST be observed. Failure to follow these recommendations can result in device failure or improper Power On Reset (POR).

1. The V₋ supply is NOT to go more positive than V_{SS} by more than 0.5V at ANY time.
2. The V₊ supply is NOT to go more negative than V_{SS} by more than -0.5V at ANY time.
3. The V_{CC} supply is NOT to go more negative than V_{SS} by more than -0.5V at ANY time.

NOTES: It is advised that the excursions above be limited to <0.3V if possible to minimize leakage effects. If any of the above situations is possible, then it is highly recommended that a clamping diode (schottky required) be added to the circuit to protect the DCP device and any other devices connected to that supply.

V_{CC} Supply Quality

The following conditions are highly recommended for proper POR:

1. The V_{CC} supply should power up with a maximum ramp rate 50V/ms and minimum ramp rate of 0.2V/ms (as per the data sheet). See Figure 2.
2. The voltage ramp on V_{CC} should be monotonic (does not reverse direction) and contain no noise greater than 100mV. See Figure 3.
3. Noise or voltage direction changes are especially significant when V_{CC} is in the range of 1.9 to 2.4V. See Figure 4.
4. If the voltage on V_{CC} reaches 1.9 to 2.4V, but has not reached 2.7V, and then falls to less than 1V, it must recover to 2.4V within 1ms or remain below 1V for more than 10ms. This is a "brownout" condition. A brownout condition that happens before V_{CC} reaches the 1.9 to 2.4V region or when V_{CC} is greater than 2.7V always retains the proper configuration. See Figure 4.

NOTES: It is possible for devices to function properly while violating one or more of these recommendations. However, these conditions are recommended to provide proper POR over a wide range of environmental, system and fabrication variations.

Power Supply Sequencing

Starting with all V_{CC}, V₋, V₊ and V_{SS} at 0V. For proper POR, the recommended power on sequence is:

1. V_{SS}.
2. V₋. V_L can be connected to V₋ and power up simultaneously with V₋.
3. V_{CC}.
4. V₊. V_H can be connected to V₊ and power up simultaneously with V₊.
5. V_W, V_L and V_H (Potentiometer Voltages) last. V_L and V_H can power up earlier as indicated above.
6. V₋ should be at least -2.7V as V_{CC} reaches 2V. If not, the POR circuit is more susceptible to V_{CC} noise and V_{CC} power-up brown-out conditions. See Figure 5.
7. V_{CC} and V₊ should be greater than 2V within 100ms of V₋ reaching the maximum value of V₋. This condition has not been known to cause POR issues, but it can stress the device as the result of improper biasing. See Figure 6.

NOTES: It may be possible to power up V_+ , V_- and V_{CC} simultaneously, or in other sequences, if V_{CC} Supply Quality conditions are met.

If the power sequencing cannot be guaranteed, then it is important to do the following:

- Add resistors to V_H , V_L and V_W to limit the current to less than 10mA into any of the terminals as shown in Figure 1.
- Make sure that the V_{CC} power supply is a clean, monotonic ramp that meets the specified ramp rate conditions.

Supplemental Information

V_- must go to a negative value first because this controls the substrate voltage, which must be stable prior to the V_{CC} turn on. This is because the Power on Recall circuit, which recalls the E2 memory contents, has a V_{CC} trip point of about 2.2 volts when V_- is in the range of -2.7 to -5.0 volts. But if V_- is at 0 volts then the POR trip point drops from 2.2 volts to about 1.9 volts and the recall operation happens at a voltage that is lower than the design value. Also, an unasserted V_- input can be pulled above V_{SS} by the application of the V_+ supply in some applications, increasing the chance of incorrect wiper recall.

V_{CC} must turn on 2nd with a ramp rate between 0.2V/ms and 50V/ms. This is required because the POR operation must be performed to set the correct wiper position before power is applied to the DCP pins (V_H and V_L). Otherwise the wiper setting could be unknown, allowing possibly excessive currents to flow between the DCP pins and the external circuits. If the ramp rate is too slow, the POR occurs when V_{CC} is too low and the wiper data may be recalled incorrectly. If the ramp rate is too fast, the POR circuit responds before the internal circuits have had a chance to “charge up”, again causing a recall when the voltage internal to the device is too low.

V_+ should turn on after V_{CC} powers up because the correct wiper position will have been recalled, leaving no chance of a transient erroneous wiper setting.

V_H , V_L and V_W voltages are generally applied last (with the exceptions noted above). This will assure a uniform power-on at the correct wiper setting and no stress on the internal circuits.

Incorrect Sequencing Issues

The X9258 has protection diodes on each of the supplies as shown in Figure 1.

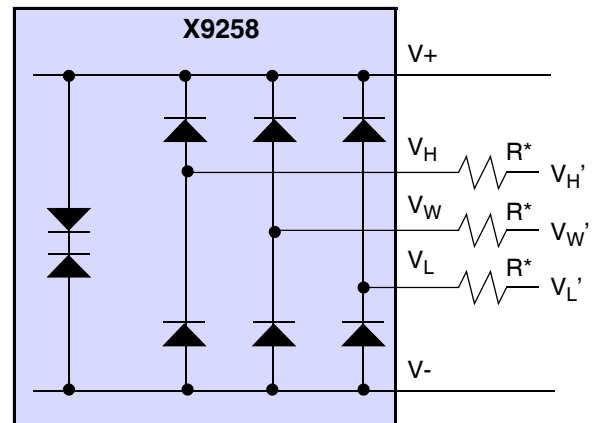

NOTE: If the power-on sequence cannot be controlled, resistors are required to protect against a worst case condition, where V_H' , V_L' or V_W' experience voltage levels that reach V_+ or V_- . Current should be limited to 10mA, so a 270 Ω resistor is required for V_+/V_- of 2.7V and a 500 Ω resistor is required for V_+/V_- of 5V.

FIGURE 1. X9258 INTERNAL PROTECTION DIODES

V_H , V_L , V_W

If these pins are powered out of sequence, and there are no current limiting resistors, then it is possible to forward bias a PN junction on the chip (which should always be reverse biased). If this occurs, damage to the chip can occur.

V_-

If V_- powers up more than 100ms before V_{CC} and V_+ , then internal biasing causes the un-controlled wiper selection FETs to partially turn on. This causes current leakage between V_+ and V_- .

Improper sequencing can cause these general issues:

8. Permanent damage which appears to be a stuck wiper position that can't be moved or set properly.
9. An SCR latchup condition which can cause large transient currents resulting in permanent damage to the device.
10. Improper recall of the non-volatile wiper setting and in rare cases improper initialization of the serial port.
11. Long term degradation of internal circuits with unknown failure mechanisms.

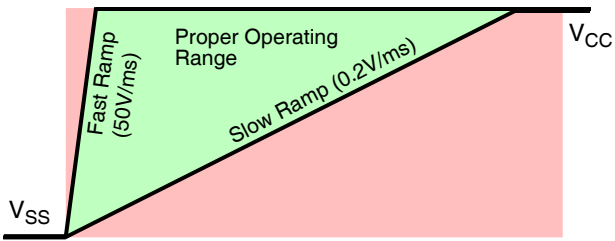

FIGURE 2. V_{CC} RISE TIME

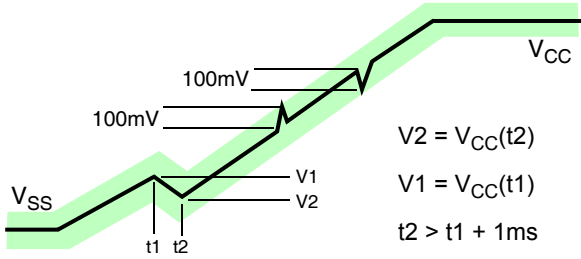

FIGURE 3. V_{CC} MONOTONICITY AND NOISE RESTRICTIONS

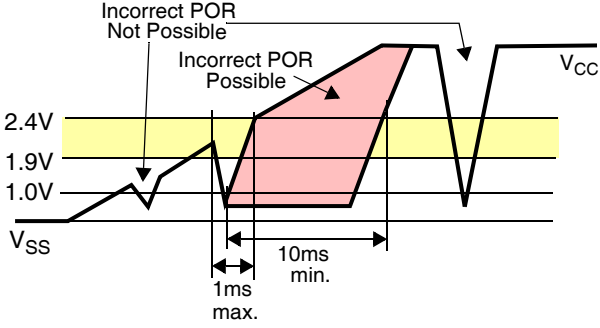

FIGURE 4. V_{CC} POWER-ON BROWN-OUT CONDITION

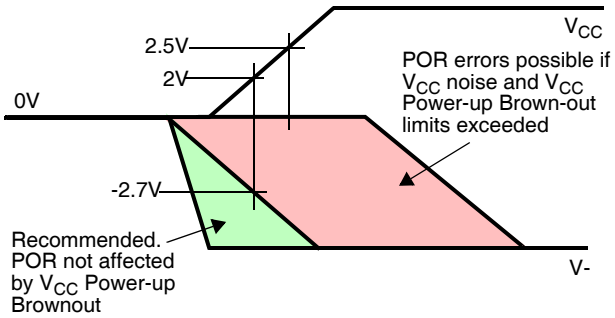

FIGURE 5. V-/V_{CC} POWER-ON TIMING

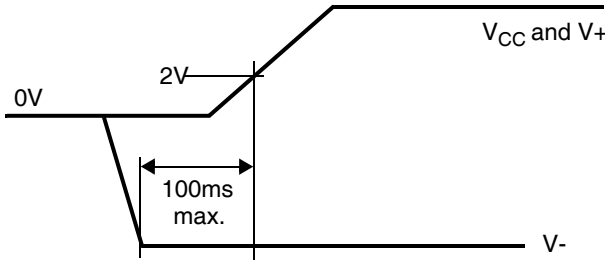

FIGURE 6. V-/V_{CC}/V₊ Power-on Timing

Notice

1. Descriptions of circuits, software and other related information in this document are provided only to illustrate the operation of semiconductor products and application examples. You are fully responsible for the incorporation or any other use of the circuits, software, and information in the design of your product or system. Renesas Electronics disclaims any and all liability for any losses and damages incurred by you or third parties arising from the use of these circuits, software, or information.
 2. Renesas Electronics hereby expressly disclaims any warranties against and liability for infringement or any other claims involving patents, copyrights, or other intellectual property rights of third parties, by or arising from the use of Renesas Electronics products or technical information described in this document, including but not limited to, the product data, drawings, charts, programs, algorithms, and application examples.
 3. No license, express, implied or otherwise, is granted hereby under any patents, copyrights or other intellectual property rights of Renesas Electronics or others.
 4. You shall not alter, modify, copy, or reverse engineer any Renesas Electronics product, whether in whole or in part. Renesas Electronics disclaims any and all liability for any losses or damages incurred by you or third parties arising from such alteration, modification, copying or reverse engineering.
 5. Renesas Electronics products are classified according to the following two quality grades: "Standard" and "High Quality". The intended applications for each Renesas Electronics product depends on the product's quality grade, as indicated below.
"Standard": Computers; office equipment; communications equipment; test and measurement equipment; audio and visual equipment; home electronic appliances; machine tools; personal electronic equipment; industrial robots; etc.
"High Quality": Transportation equipment (automobiles, trains, ships, etc.); traffic control (traffic lights); large-scale communication equipment; key financial terminal systems; safety control equipment; etc.
Unless expressly designated as a high reliability product or a product for harsh environments in a Renesas Electronics data sheet or other Renesas Electronics document, Renesas Electronics products are not intended or authorized for use in products or systems that may pose a direct threat to human life or bodily injury (artificial life support devices or systems; surgical implantations; etc.), or may cause serious property damage (space system; undersea repeaters; nuclear power control systems; aircraft control systems; key plant systems; military equipment; etc.). Renesas Electronics disclaims any and all liability for any damages or losses incurred by you or any third parties arising from the use of any Renesas Electronics product that is inconsistent with any Renesas Electronics data sheet, user's manual or other Renesas Electronics document.
 6. When using Renesas Electronics products, refer to the latest product information (data sheets, user's manuals, application notes, "General Notes for Handling and Using Semiconductor Devices" in the reliability handbook, etc.), and ensure that usage conditions are within the ranges specified by Renesas Electronics with respect to maximum ratings, operating power supply voltage range, heat dissipation characteristics, installation, etc. Renesas Electronics disclaims any and all liability for any malfunctions, failure or accident arising out of the use of Renesas Electronics products outside of such specified ranges.
 7. Although Renesas Electronics endeavors to improve the quality and reliability of Renesas Electronics products, semiconductor products have specific characteristics, such as the occurrence of failure at a certain rate and malfunctions under certain use conditions. Unless designated as a high reliability product or a product for harsh environments in a Renesas Electronics data sheet or other Renesas Electronics document, Renesas Electronics products are not subject to radiation resistance design. You are responsible for implementing safety measures to guard against the possibility of bodily injury, injury or damage caused by fire, and/or danger to the public in the event of a failure or malfunction of Renesas Electronics products, such as safety design for hardware and software, including but not limited to redundancy, fire control and malfunction prevention, appropriate treatment for aging degradation or any other appropriate measures. Because the evaluation of microcomputer software alone is very difficult and impractical, you are responsible for evaluating the safety of the final products or systems manufactured by you.
 8. Please contact a Renesas Electronics sales office for details as to environmental matters such as the environmental compatibility of each Renesas Electronics product. You are responsible for carefully and sufficiently investigating applicable laws and regulations that regulate the inclusion or use of controlled substances, including without limitation, the EU RoHS Directive, and using Renesas Electronics products in compliance with all these applicable laws and regulations. Renesas Electronics disclaims any and all liability for damages or losses occurring as a result of your noncompliance with applicable laws and regulations.
 9. Renesas Electronics products and technologies shall not be used for or incorporated into any products or systems whose manufacture, use, or sale is prohibited under any applicable domestic or foreign laws or regulations. You shall comply with any applicable export control laws and regulations promulgated and administered by the governments of any countries asserting jurisdiction over the parties or transactions.
 10. It is the responsibility of the buyer or distributor of Renesas Electronics products, or any other party who distributes, disposes of, or otherwise sells or transfers the product to a third party, to notify such third party in advance of the contents and conditions set forth in this document.
 11. This document shall not be reprinted, reproduced or duplicated in any form, in whole or in part, without prior written consent of Renesas Electronics.
 12. Please contact a Renesas Electronics sales office if you have any questions regarding the information contained in this document or Renesas Electronics products.
- (Note 1) "Renesas Electronics" as used in this document means Renesas Electronics Corporation and also includes its directly or indirectly controlled subsidiaries.
(Note 2) "Renesas Electronics product(s)" means any product developed or manufactured by or for Renesas Electronics.

(Rev.4.0-1 November 2017)



SALES OFFICES

Renesas Electronics Corporation

<http://www.renesas.com>

Refer to "<http://www.renesas.com/>" for the latest and detailed information.

Renesas Electronics America Inc.
1001 Murphy Ranch Road, Milpitas, CA 95035, U.S.A.
Tel: +1-408-432-8888, Fax: +1-408-434-5351

Renesas Electronics Canada Limited
9251 Yonge Street, Suite 8309 Richmond Hill, Ontario Canada L4C 9T3
Tel: +1-905-237-2004

Renesas Electronics Europe Limited
Dukes Meadow, Millboard Road, Bourne End, Buckinghamshire, SL8 5FH, U.K
Tel: +44-1628-651-700, Fax: +44-1628-651-804

Renesas Electronics Europe GmbH
Arcadiastrasse 10, 40472 Düsseldorf, Germany
Tel: +49-211-6503-0, Fax: +49-211-6503-1327

Renesas Electronics (China) Co., Ltd.
Room 1709 Quantum Plaza, No.27 ZhichunLu, Haidian District, Beijing, 100191 P. R. China
Tel: +86-10-8235-1155, Fax: +86-10-8235-7679

Renesas Electronics (Shanghai) Co., Ltd.
Unit 301, Tower A, Central Towers, 555 Langao Road, Putuo District, Shanghai, 200333 P. R. China
Tel: +86-21-2226-0888, Fax: +86-21-2226-0999

Renesas Electronics Hong Kong Limited
Unit 1601-1611, 16/F., Tower 2, Grand Century Place, 193 Prince Edward Road West, Mongkok, Kowloon, Hong Kong
Tel: +852-2265-6688, Fax: +852-2886-9022

Renesas Electronics Taiwan Co., Ltd.
13F, No. 363, Fu Shing North Road, Taipei 10543, Taiwan
Tel: +886-2-8175-9600, Fax: +886-2-8175-9670

Renesas Electronics Singapore Pte. Ltd.
80 Bendemeer Road, Unit #06-02 Hyflux Innovation Centre, Singapore 339949
Tel: +65-6213-0200, Fax: +65-6213-0300

Renesas Electronics Malaysia Sdn.Bhd.
Unit 1207, Block B, Menara Amcorp, Amcorp Trade Centre, No. 18, Jln Persiaran Barat, 46050 Petaling Jaya, Selangor Darul Ehsan, Malaysia
Tel: +60-3-7955-9390, Fax: +60-3-7955-9510

Renesas Electronics India Pvt. Ltd.
No.777C, 100 Feet Road, HAL 2nd Stage, Indiranagar, Bangalore 560 038, India
Tel: +91-80-67208700, Fax: +91-80-67208777

Renesas Electronics Korea Co., Ltd.
17F, KAMCO Yangjae Tower, 262, Gangnam-daero, Gangnam-gu, Seoul, 06265 Korea
Tel: +82-2-558-3737, Fax: +82-2-558-5338