

Interfacing the X9408, X9418 XDCP to 8051 Microcontrollers

This application note describes the routines for the control of an X9408 or X9418 digitally controllable potentiometer. The X9408, X9418 devices have a variety of different instructions that provide flexibility to the designer. Additionally, the nonvolatile nature of the device allows for stored wiper positions that can be retrieved after power cycles.

The following code implements all of the available X9408, X9418 instructions using a standard bi-directional bus protocol. Although the subroutines occupy about 300 bytes of program memory, designers who won't need to implement all of the instructions can shorten the code by removing any unnecessary routines. However, this will necessitate the reassembly of the code.

For those instructions which program the nonvolatile data registers (XFR_WCR, GXFR_WCR, & WRITE_DR), acknowledge polling has been implemented to determine an early completion of the internal write cycle. Although this is automatically handled by the routines, a word or two regarding the procedure should be informative. After issuing a start condition, the master sends a slave address and receives an acknowledge. It then issues an instruction byte to the X9408, X9418 and again receives an acknowledge. If necessary, it now transmits the data byte and receives a final acknowledge. The master must then initiate a stop condition which will cause the X9408, X9418 to begin an internal write cycle. The X9408, X9418 pins go to high impedance until this internal cycle is complete. The master can now begin

acknowledge polling by successively sending start conditions followed by "dummy" instructions. When the X9408, X9418 finally answers with an acknowledge, the internal write cycle has been completed. The master must then initiate a stop condition. After the next start condition, the X9408, X9418 is ready to receive further instructions.

In the code listing, an assumption was made that the code executes upon a reset of the microcontroller. That is, the code is loaded into low memory, however this can be changed with an ORG assembler directive. Simple MAIN program routines are included in the code listing. These can be modified for different device addresses, different registers and different DCPs within the device.

In this listing, the commands cause an X9408, X9418 (at A3A2A1A0 = 1100 to be accessed.) The listing also includes some instructions that are specific to the Cygnal 80C51 processor. These should be examined and modified, as needed, for the specific 80C51 in the system. The commands issued in the "Main" section of the code are simple assignment and call sequences.

In Figure 1, a representative hardware connection between the X9408 and an 8051 family microcontroller is shown. The pull-up resistors on the SDA and SCL lines are determined by the total capacitance of all of the devices connected to the bus, which is about 18pF.

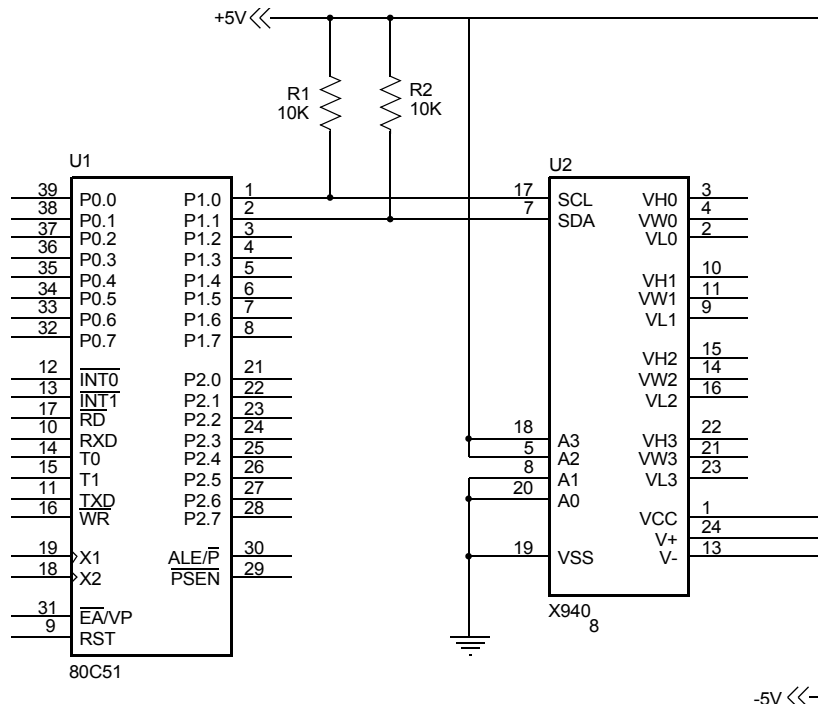

FIGURE 1. CONNECTING THE X9408 TO AN 80C51 MICROCONTROLLER

80C51 MICROCONTROLLER ROUTINES FOR MANIPULATING AN X9408

```

-----
;
; 80C51 MICROCONTROLLER ROUTINES FOR MANIPULATING AN X9408
;           QUAD EEPOT
;
;           (C) INTERSIL INC. 2002
;
;                               CEM
;
; FILE NAME   : X9408 8051.TXT
; TARGET MCU  : Cygnal C8051F000
; DESCRIPTION:
;
; This code provides basic 80C51 code for communicating with and
; controlling the X9408 quad digital potentiometer. In this listing
; is code that implements all of the available X9408 instructions.
; The X9408 communicates via a 2-wire bus that is similar, but a little
; different from the I2C bus. This code is very generic and can be
; simplified and shortened by removing any unnecessary routines.
;
; For those instructions which program the nonvolatile data registers
; (XFR_WCR, GFXR_WCR, and WRITE_DR) this program provides acknowledge
; polling to determine early completion of the internal write cycle.
; Although this is handled automatically by the routines, some background
; might be helpful.
;
; After issuing a start condition, the master sends a slave address
; and receives and acknowledge (ACK). The master then sends an instruction
; byte to the X9408 and again receives an ACK. If necessary, the master sends
; a data byte and receives a final ACK. The master then initiates a stop
; condition to signal the X9408 to begin an internal nonvolatile write
; cycle. When the write cycle begins, the I/O pins go to a high impedance state
; and remain in this state until the nonvolatile write is complete.
;
; Immediately following the stop condition, the master can begin acknowledge
; polling by successively sending start conditions, followed by "dummy"
; instructions. When the X9408 finally answers with an acknowledge, the
; internal write cycle is completed. The master then issues a stop
; condition. After the next start condition, the X9408 is ready to receive
; further instructions.
;
; This code give the flexibility to communicate with up to 16 different X9408
; devices on the same bus. It does this by using a register, named "ADDR_BYTE".
; This register is loaded with the specific slave address and address of the
; desired X9408 device. The register can be saved if there is only one X9408
; on the bus, by making ADDR_BYTE a constant.
;
; An 80C51 register is used to identify the particular X9408 register or DCP, or both,
; are used for a particular operation. There are various constants available for
; easy selection of the WCR and DR combination. The contents of the register
; is appended to the specific instruction in the "instr_gen" routine.
;
; A register is used as a counter for keeping track of the number of bits sent
; in each byte.
;
; A register is used for the increment/decrement instruction to specify up or
; down movement of the wiper. For each command, the master loads the "PULSES"
; register with a direction bit and 6 bits of count. If the MSB is a 1
; the wiper increments the specified number of tap positions. If the MSB
; is a 0 the wiper decrements the specified number of tap positions.
;
; A register is used to hold the specific command being executed. This allows
; the instruction to be built up and sent to the X9408.
;
; In the MAIN section are sample main code segments showing how to use the
; various subroutines.
;
; This code was tested on a Cygnal 80C51 microcontroller, using the Cygnal
; tools. The specific routines required to set up the Cygnal processor

```

```

; are identified and are probably not needed for other standard 8051 devices.
; Since each 8051 may have specific requirements that are not handled in this
; code, the programmer is advised to check the setup needs of the specific
; 80C51 derivation that is being used.
;
;-----
; I/O Definition
;-----

SCL          bit    p1.0    ; 80C51 pin used AS SCL
SDA          bit    p1.1    ; 80C51 pin used AS SDA

;-----
; Register Definition
;-----

#include (c8051f000.inc); Include register definition file (Cygna).

TEMP        equ    r1      ; Scratch register
COUNT      equ    r2      ; Loop counting register
PULSES      equ    r3      ; Bits -> DIR 0 ##### (#=pulses = 0 to 64)
COMMAND     equ    r4      ; Instruction (I.E. 0,4,8,12,16,...)
ID          equ    r5      ; Bits -> 0 0 0 0 R1 R0 P1 P0
ADDR_BYTE   equ    r6      ; Bits -> 0 1 0 1 A3 A2 A1 A0
DATA_BYTE   equ    r7      ; Bits -> CM DW D5 D4 D3 D2 D1 D0

;-----
; Constant Definition
;-----

SLAVE_ADR0  equ    050h
SLAVE_ADR1  equ    051h
SLAVE_ADR2  equ    052h
SLAVE_ADR3  equ    053h
SLAVE_ADR4  equ    054h
SLAVE_ADR5  equ    055h
SLAVE_ADR6  equ    056h
SLAVE_ADR7  equ    057h
SLAVE_ADR8  equ    058h
SLAVE_ADR9  equ    059h
SLAVE_ADR10 equ    05Ah
SLAVE_ADR11 equ    05Bh
SLAVE_ADR12 equ    05Ch
SLAVE_ADR13 equ    05Dh
SLAVE_ADR14 equ    05Eh
SLAVE_ADR15 equ    05Fh

;
WCR_0       equ    00h
WCR_1       equ    01h
WCR_2       equ    02h
WCR_3       equ    03h

;
DR_0        equ    00h
DR_1        equ    04h
DR_2        equ    08h
DR_3        equ    0Ch

;
DCP0_R0     equ    00h
DCP0_R1     equ    04h
DCP0_R2     equ    08h
DCP0_R3     equ    0Ch

;
DCP1_R0     equ    01h
DCP1_R1     equ    05h
DCP1_R2     equ    09h
DCP1_R3     equ    0Dh

;
DCP2_R0     equ    02h
DCP2_R1     equ    06h
DCP2_R2     equ    0Ah

```

```

DCP2_R3      equ    0Eh
;
DCP3_R0      equ    03h
DCP3_R1      equ    07h
DCP3_R2      equ    0Bh
DCP3_R3      equ    0Fh
;

READWCR      equ    0
WRITEWCR     equ    4
READDR       equ    8
WRITEDR      equ    12
XFRDR        equ    16
XFRWCR       equ    20
GXFRDR       equ    24
GXFRWCR      equ    28
INCDECWIPER  equ    32

;-----
; INTERNAL RAM
;-----

STACK_TOP    equ    060H    ; Stack top

;-----
; RESET and INTERRUPT VECTORS
;-----

        cseg AT 0
        ljmp main           ; Locate a jump to the start of code at

;-----
; CODE SEGMENT
;-----

Code_Seg    segment    CODE

        rseg      Code_Seg    Switch to this code segment.
        using     Specify register bank for the following
                  program code.

;-----
;
; NAME: execute
; FUNCTION: Determines which X9408 instruction is issued,
;           then executes
; INPUTS: COMMAND
; OUTPUTS: none
; CALLS: read_wcr, read_dr, write_wcr, write_dr, xfr_dr,
;        xfr_wcr, gxfr_dr, gxfr_wcr, inc_wiper
; AFFECTED: DPTR, A
;
;-----

execute:
        mov     dptr,#first    ; Get Base Address
        mov     a,COMMAND      ; Jump Offset
        jmp     @a+dptr        ; Jump to instruction handler

first:
        call   read_wcr        ; COMMAND #0
        ret
        call   write_wcr       ; COMMAND #4
        ret
        call   read_dr         ; COMMAND #8
        ret
        call   write_dr        ; COMMAND #12
        ret
        call   xfr_dr          ; COMMAND #16
        ret

```

```

    call  xfr_wcr      ; COMMAND #20
    ret
    call  gxfr_dr     ; COMMAND #24
    ret
    call  gxfr_wcr    ; COMMAND #28
    ret
    call  inc_wiper   ; COMMAND #32
    ret
;-----
;
; The following routines handle each X9408 instruction.
; These are called by the "execute" routine.
;
; read_wcrReads a WCR and returns its value in DATA_BYTE
; write_wcrWrites the value in DATA_BYTE to a WCR
; read_drReads a Data Register and returns its value in DATA_BYTE
; write_drWrites the value in DATA_BYTE to a data register
; xfr_drTransfers the value in a data register to its WCR
; xfr_wcrTransfers the value in a WCR to one of its data registers
; gxfr_drGlobal transfer of data registers to WCRs
; gxfr_wcrGlobal transfer of WCRs to Data Registers
; inc_wiperSingle Step Increment/Decrement of wiper position for WCR
;
; FUNCTION: Appends bits R1, R0, P1, P0 to the appropriate
;           Instruction code and passes the instruction byte to the
;           Instruction Generator.
; INPUTS:  ID
; OUTPUTS: NONE
; CALLS:  instr_gen
; AFFECTED: ID,A,DPTR
;-----

read_wcr:
    mov    a, ID      ; Get bits x x P1 P0
    orl    a, #090h   ; Append to read WCR instruction code
    mov    ID, a      ; Save the result
    mov    dptr, #case1 ; Jump to the base addr for this instrucion
    call   instr_gen
    ret

write_wcr:
    mov    a, ID      ; Get bits x x P1 P0
    orl    a, #0A0h   ; Append to Write WCR instruction code
    mov    ID, a      ; Save the result
    mov    dptr, #case2 ; Jump to the base addr for this instruction
    call   instr_gen
    ret

read_dr:
    mov    a, ID      ; Get bits R1 R0 P1 P0
    orl    a, #0B0h   ; Append to Read DR instruction code
    mov    ID, a      ; Save the result
    mov    dptr, #case1 ; Jump to the base addr for this instruction
    call   instr_gen
    ret

write_dr:
    mov    a, ID      ; Get bits R1 R0 P1 P0
    orl    a, #0C0h   ; Append to Write DR instruction code
    mov    ID, a      ; Save the result
    mov    dptr, #case3 ; Jump to the base addr for this instruction
    call   instr_gen
    ret

xfr_dr:
    mov    a, ID      ; Get bits R1 R0 P1 P0
    orl    a, #0D0h   ; Append to the XFR DR instruction code
    mov    ID, a      ; Save the result

```

```

    mov    dptr,#case4 ; Jump to the addr for this instruction
    call  instr_gen
    ret

xfr_wcr:
    mov    a,ID        ; Get bits R1 R0 P1 P0
    orl    a,#0E0h     ; Append to the XFR WCR instruction code
    mov    ID, a       ; Save the result
    mov    dptr,#case5 ; Jump to the addr for this instruction
    call  instr_gen
    ret

gxfr_dr:
    mov    a,ID        ; Get bits R1 R0 x x
    orl    a,#010h     ; Append to the GXFR DR instruction code
    mov    ID, a       ; Save the result
    mov    dptr,#case4 ; Jump to the addr for this instruction
    call  instr_gen
    ret

gxfr_wcr:
    mov    a,ID        ; Get bits R1 R0 x x
    orl    a,#080h     ; Append to the GXFR WCR instruction code
    mov    ID, a       ; Save the result
    mov    dptr,#case5 ; Jump to the addr for this instruction
    call  instr_gen
    ret

inc_wiper:
    mov    a,ID        ; Get bits x x P1 P0
    orl    a,#020h     ; Append to the Incr Wiper instruction code
    mov    ID,a        ; Save the result
    mov    dptr,#case6 ; Jump to the addr for this instruction
    call  instr_gen
    ret

;-----
;
; NAME: instr_gen (Instruction generator)
; FUNCTION: Issues appropriate I2C protocol for each X9408 instruction
; INPUTS: ADDR_BYTE, ID, PULSES, DPTR, DATA_BYTE
; OUTPUTS: DATA_BYTE
; CALLS: start_cond, stop_cond, send_byte, send_bit, get_byte, polling
; AFFECTED: DATA_BYTE, A, COUNT
;-----

instr_gen:
    call  start_cond   ; Issue an I2C start condition
    mov    a,ADDR_BYTE ; Send X9408 slave/address byte
    call  send_byte
    jc    stop_gen     ; if NACK, end...
    mov    a,ID        ; Send X9408 instruction byte
    call  send_byte
    jc    stop_gen     ; if NACK, end...
    clr    a           ; Reset offset before jump
    jmp   @a +dptr    ; Jump to various instruction cases

case6:
    mov    a,PULSES    ; A <- Bits DIR X D5 D4 D3 D2 D1 D0
    anl    a,#00111111b ; A <- Bits 0 0 D5 D4 D3 D2 D1 D0
    mov    COUNT, a    ; Save as the number of pulses
    mov    a,PULSES
    anl    a,#10000000b ; A <- Bits DIR 0 0 0 0 0 0 0

wiper_lp:
    call  send_bit     ; Send the bit (a single pulse)
    djnz COUNT,wiper_lp ; Continue until all pulses are sent

case4:

```

```

        jmp    stop_gen    ; If program gets here, then it is done

case2:
    mov    a,DATA_BYTE    ; Send X9408 data byte
    call   send_byte
    jmp    stop_gen

case1:
    call   get_byte       ; Receive X9408 Data Byte
    jmp    stop_gen

case3:
    mov    a,DATA_BYTE    ; Send X9408 Data Byte
    call   send_byte
    call   stop_cond      ; Issue a stop condition
    call   polling        ; Begin Acknowledge Polling
    jmp    stop_gen

case5:
    call   stop_cond      ; Issue a stop condition
    call   polling        ; Begin Acknowledge Polling

stop_gen:
    call   stop_cond      ; I2C Transmission Over!
    ret

;-----
;
; NAME: send_byte
; FUNCTION: Sends 8 bits (from MSB to LSB) to SDA and reads 1 bit from SDA
; INPUTS: A
; OUTPUTS: NONE
; CALLS: send_bit, get_bit
; AFFECTED: COUNT, TEMP, A
;-----

send_byte:
    mov    COUNT,#8      ; Set loop for 8 repetitions
    mov    TEMP,a        ; store as shifted byte (no shift)

bit_loop:
    mov    a,TEMP        ; Retrieve last saved shifted byte
    anl   a,#10000000b   ; Mask for MSB (Most Significant Bit)
    call   send_bit      ; Place this bit on SDA

next_bit:
    mov    a,TEMP        ; Retrieve last saved shifted byte
    rl    a              ; Rotate all bits 1 position left
    mov    TEMP,a        ; Store this updated shifted byte
    djnz  COUNT,bit_loop
    setb  SDA            ; let SDA go high after 8th bit
    call  clock          ; When all 8 bits done, read SDA line
                    ; (ACKnowledge pulse)
    ret

;-----
;
; NAME: send_bit
; FUNCTION: Places a bit on SDA and initiates a clock pulse on SCL
; INPUTS: A
; OUTPUTS: NONE
; CALLS: clock
; AFFECTED: SDA
;-----

send_bit:
    clr   SDA            ; Pull SDA Low
    jz    sent_zero     ; Should SDA really be LOW?

```

```

        setb   SDA            ; If Not, pull SDA HIGH
sent_zero:
        call  clock          ; Initiate a clock pulse
        ret

;-----
;
; NAME: clock
; FUNCTION: Issues a LOW-HIGH-LOW clock pulse of sufficient duration
;          & reads SDA during the high phase, just in case its needed
; INPUTS: NONE
; OUTPUTS: C
; CALLS: NONE
; AFFECTED: SCL, C
;-----
clock:
        nop                ; Let SDA Set-up
        setb   SCL          ; Pull SCL HIGH and hold
        nop
        nop
        nop
        mov    c,SDA        ; Move SDA bit into carry flag
        clr    SCL          ; Pull SCL LOW
        ret

;-----
;
; NAME: get_byte
; FUNCTION: Receives 8 bits from SDA (MSB to LSB) and sends 1 bit to SDA
; INPUTS: NONE
; OUTPUTS: DATA_BYTE
; CALLS: clock, send_bit
; AFFECTED: COUNT, SDA, A, DATA_BYTE
;-----
get_byte:
        setb   SDA          ; Receiver shouldn't drive SDA low
        mov    COUNT,#8     ; Set Loop count to 8 repetitions

get_loop:
        call  clock         ; Clock in the current bit
        rlc   a             ; Reconstruct byte using left shifts
        djnz  COUNT,get_loop
        mov   DATA_BYTE,a  ; Store retrieved Byte for user
        clr   a             ; A <- LOW (Sending a 0)
        call  send_bit      ; Send an acknowledge
        ret

;-----
;
; NAME: start_cond (Start Condition)
; FUNCTION: Issues an I2C bus start condition
; INPUTS: NONE
; OUTPUTS: NONE
; CALLS: NONE
; AFFECTED: SDA, SCL
;-----
start_cond:
        setb   SDA          ; Pull SDA HIGH and allow set-up
        setb   SCL          ; Pull SCL HIGH and hold
        nop
        nop
        nop
        nop
        clr   SDA           ; Pull SDA LOW (SCL=HIGH) and hold

```



```

    nop
    nop
    nop
    nop
    clr    SCL          ;Complete clock pulse
    ret

;-----
;
; NAME: stop_cond (Stop condition)
; FUNCTION: Issues an I2C bus stop condition
; INPUTS: NONE
; OUTPUTS: NONE
; CALLS: NONE
; AFFECTED: SDA, SCL
;
;-----

stop_cond:
    clr    SDA          ; Pull SDA LOW and hold
    setb   SCL          ; Pull SCL HIGH and hold
    nop
    nop
    nop
    nop
    setb   SDA          ; Pull SDA HIGH (SCL=HIGH)
    ret

;-----
;
; NAME: ack_send (Send Acknowledge)
; FUNCTION: Sends an acknowledge bit to complete SDA line data reads
; INPUTS: NONE
; OUTPUTS: NONE
; CALLS: send_bit
; AFFECTED: A
;
;-----

ack_send:
    clr    a            ; A <- LOW (Sending a 0)
    call   SEND_BIT    ; Send the bit!
    ret

;-----
;
; NAME: polling (Acknowledge polling for XFR_WCR, WRITE_DR, GXFR_WCR)
; FUNCTION: Sends dummy commands to X9408 during an internal write cycle
;           so that the end of the cycle is marked by an acknowledge
; INPUTS: ADDR_BYTE
; OUTPUTS: NONE
; CALLS: start_cond, send_byte
; AFFECTED: C
;
;-----

polling:
    call   START_COND  ; Re-establish I2C protocol
    mov    a,ADDR_BYTE ; Attempt to send a dummy command

again:
    call   SEND_BYTE
    jc    POLLING      ; If C=1, then there was no ACK

    ret

;-----
;
; PUT MAIN PROGRAM HERE...
;

```

```

; Below are sample main programs calling the various command routines
;
;-----
main:
    mov    SP, #STACK_TOP; Initialize stack pointer

;-----
;
; The following section is required for the Cygnal processor. This could
; change for different versions of the 80C51.
;
; Disable the WDT. (IRQs not enabled at this point.)
; If interrupts were enabled, they would need to be explicitly disabled
; so that the 2nd move to WDTCN occurs no more than four clock
; cycles after the first move to WDTCN.

    clr    EA            ; Disable interrupts

    mov    WDTCN, #0DEh; Cygnal processor specific
    mov    WDTCN, #0ADh; Cygnal processor specific

; Enable the Port I/O Crossbar

    mov    XBR2, #40h    ; Cygnal processor specific (enable weak pull ups)

    mov    PRT1CF, #00h ; Cygnal processor specific
                        ; Set no ports as push-pull (this processor
                        ; operates from 3.3V, but the X9408 operates from
                        ; 5V, so the 8051 outputs must be pulled up to 5V
                        ; with external resistors.)

;-----
;
; The following are sample code segments for use in the main program...
; The potentiometer was A0-A3 pins were set to address 0Ch.
;
;-----
write_2_wcr:
    mov    ADDR_BYTE, #SLAVE_ADR12; Load Slave address byte
    mov    ID, #WCR_2    ; Specify WCR for DCP#2
    mov    COMMAND, #WRITEWCR; Write to WCR
    mov    DATA_BYTE, #43; Set wiper position to tap 43
    call   execute

read_from_wcr:
    mov    ADDR_BYTE, #SLAVE_ADR12; Load Slave address byte
    mov    ID, #WCR_2    ; Specify WCR for DCP#2
    mov    COMMAND, #READWCR; Read WCR
    call   execute      ; WCR value is in DATA_BYTE

write_2_dr:
    mov    ADDR_BYTE, #SLAVE_ADR12; Load Slave address byte
    mov    ID, #DCP2_R1; Specify DR#1 for DCP#2
    mov    COMMAND, #WRITEDR; Write to DR
    mov    DATA_BYTE, #21; Set data value to 21
    call   execute

read_from_dr:
    mov    ADDR_BYTE, #SLAVE_ADR12; Load Slave address byte
    mov    ID, #DCP2_R1; Specify DR#1 for DCP#2
    mov    COMMAND, #READDR; Read DR
    call   execute      ; DR value is in DATA_BYTE

mov_dr_2_wcr:
    mov    ADDR_BYTE, #SLAVE_ADR12; Load Slave address byte
    mov    ID, #DCP2_R1; Specify DR#1 to WCR of DCP#2
    mov    COMMAND, #XFRDR; Transfer DR to WCR

```

```
    call    execute

mov_wcr_2_dr:
    mov     ADDR_BYTE, #SLAVE_ADR12; Load Slave address byte
    mov     ID, #DCP2_R1; Specify WCR to DR#1 of DCP#2
    mov     COMMAND, #XFRWCR; Transfer WCRto DR
    call    execute

global_dr_2_wcr:
    mov     ADDR_BYTE, #SLAVE_ADR12; Load Slave address byte
    mov     ID, #DR_1    ; Specify DR#1 to WCR
    mov     COMMAND, #GXFRDR; Transfer DR to WCR
    call    execute

global_wcr_2_dr:
    mov     ADDR_BYTE, #SLAVE_ADR12; Load Slave address byte
    mov     ID, #DR_1    ; Specify WCR to DR#1 of DCP#2
    mov     COMMAND, #GXFRWCR; Transfer WCRto DR
    call    execute

decr_wiper:
    mov     ADDR_BYTE, #SLAVE_ADR12; Load Slave address byte
    mov     ID, #WCR_2    ; Select DCP#2
    mov     PULSES, #0Fh; Decrement DCP#2 for 16 pulses
    mov     COMMAND, #INCDECWIPER; INC wiper
    call    execute

incr_wiper:
    mov     ADDR_BYTE, #SLAVE_ADR12; Load Slave address byte
    mov     ID, #WCR_2    ; Select DCP#2
    mov     PULSES, #8Fh; Increment DCP#2 for 16 pulses
    mov     COMMAND, #INCDECWIPER; DEC wiper
    call    execute

    END
```

Notice

1. Descriptions of circuits, software and other related information in this document are provided only to illustrate the operation of semiconductor products and application examples. You are fully responsible for the incorporation or any other use of the circuits, software, and information in the design of your product or system. Renesas Electronics disclaims any and all liability for any losses and damages incurred by you or third parties arising from the use of these circuits, software, or information.
2. Renesas Electronics hereby expressly disclaims any warranties against and liability for infringement or any other claims involving patents, copyrights, or other intellectual property rights of third parties, by or arising from the use of Renesas Electronics products or technical information described in this document, including but not limited to, the product data, drawings, charts, programs, algorithms, and application examples.
3. No license, express, implied or otherwise, is granted hereby under any patents, copyrights or other intellectual property rights of Renesas Electronics or others.
4. You shall not alter, modify, copy, or reverse engineer any Renesas Electronics product, whether in whole or in part. Renesas Electronics disclaims any and all liability for any losses or damages incurred by you or third parties arising from such alteration, modification, copying or reverse engineering.
5. Renesas Electronics products are classified according to the following two quality grades: "Standard" and "High Quality". The intended applications for each Renesas Electronics product depends on the product's quality grade, as indicated below.
"Standard": Computers; office equipment; communications equipment; test and measurement equipment; audio and visual equipment; home electronic appliances; machine tools; personal electronic equipment; industrial robots; etc.
"High Quality": Transportation equipment (automobiles, trains, ships, etc.); traffic control (traffic lights); large-scale communication equipment; key financial terminal systems; safety control equipment; etc.
Unless expressly designated as a high reliability product or a product for harsh environments in a Renesas Electronics data sheet or other Renesas Electronics document, Renesas Electronics products are not intended or authorized for use in products or systems that may pose a direct threat to human life or bodily injury (artificial life support devices or systems; surgical implantations; etc.), or may cause serious property damage (space system; undersea repeaters; nuclear power control systems; aircraft control systems; key plant systems; military equipment; etc.). Renesas Electronics disclaims any and all liability for any damages or losses incurred by you or any third parties arising from the use of any Renesas Electronics product that is inconsistent with any Renesas Electronics data sheet, user's manual or other Renesas Electronics document.
6. When using Renesas Electronics products, refer to the latest product information (data sheets, user's manuals, application notes, "General Notes for Handling and Using Semiconductor Devices" in the reliability handbook, etc.), and ensure that usage conditions are within the ranges specified by Renesas Electronics with respect to maximum ratings, operating power supply voltage range, heat dissipation characteristics, installation, etc. Renesas Electronics disclaims any and all liability for any malfunctions, failure or accident arising out of the use of Renesas Electronics products outside of such specified ranges.
7. Although Renesas Electronics endeavors to improve the quality and reliability of Renesas Electronics products, semiconductor products have specific characteristics, such as the occurrence of failure at a certain rate and malfunctions under certain use conditions. Unless designated as a high reliability product or a product for harsh environments in a Renesas Electronics data sheet or other Renesas Electronics document, Renesas Electronics products are not subject to radiation resistance design. You are responsible for implementing safety measures to guard against the possibility of bodily injury, injury or damage caused by fire, and/or danger to the public in the event of a failure or malfunction of Renesas Electronics products, such as safety design for hardware and software, including but not limited to redundancy, fire control and malfunction prevention, appropriate treatment for aging degradation or any other appropriate measures. Because the evaluation of microcomputer software alone is very difficult and impractical, you are responsible for evaluating the safety of the final products or systems manufactured by you.
8. Please contact a Renesas Electronics sales office for details as to environmental matters such as the environmental compatibility of each Renesas Electronics product. You are responsible for carefully and sufficiently investigating applicable laws and regulations that regulate the inclusion or use of controlled substances, including without limitation, the EU RoHS Directive, and using Renesas Electronics products in compliance with all these applicable laws and regulations. Renesas Electronics disclaims any and all liability for damages or losses occurring as a result of your noncompliance with applicable laws and regulations.
9. Renesas Electronics products and technologies shall not be used for or incorporated into any products or systems whose manufacture, use, or sale is prohibited under any applicable domestic or foreign laws or regulations. You shall comply with any applicable export control laws and regulations promulgated and administered by the governments of any countries asserting jurisdiction over the parties or transactions.
10. It is the responsibility of the buyer or distributor of Renesas Electronics products, or any other party who distributes, disposes of, or otherwise sells or transfers the product to a third party, to notify such third party in advance of the contents and conditions set forth in this document.
11. This document shall not be reprinted, reproduced or duplicated in any form, in whole or in part, without prior written consent of Renesas Electronics.
12. Please contact a Renesas Electronics sales office if you have any questions regarding the information contained in this document or Renesas Electronics products.
(Note 1) "Renesas Electronics" as used in this document means Renesas Electronics Corporation and also includes its directly or indirectly controlled subsidiaries.
(Note 2) "Renesas Electronics product(s)" means any product developed or manufactured by or for Renesas Electronics.

(Rev.4.0-1 November 2017)



SALES OFFICES

Renesas Electronics Corporation

<http://www.renesas.com>

Refer to "<http://www.renesas.com/>" for the latest and detailed information.

Renesas Electronics America Inc.
1001 Murphy Ranch Road, Milpitas, CA 95035, U.S.A.
Tel: +1-408-432-8888, Fax: +1-408-434-5351

Renesas Electronics Canada Limited
9251 Yonge Street, Suite 8309 Richmond Hill, Ontario Canada L4C 9T3
Tel: +1-905-237-2004

Renesas Electronics Europe Limited
Dukes Meadow, Millboard Road, Bourne End, Buckinghamshire, SL8 5FH, U.K.
Tel: +44-1628-651-700, Fax: +44-1628-651-804

Renesas Electronics Europe GmbH
Arcadiastrasse 10, 40472 Düsseldorf, Germany
Tel: +49-211-6503-0, Fax: +49-211-6503-1327

Renesas Electronics (China) Co., Ltd.
Room 1709 Quantum Plaza, No.27 ZhichunLu, Haidian District, Beijing, 100191 P. R. China
Tel: +86-10-8235-1155, Fax: +86-10-8235-7679

Renesas Electronics (Shanghai) Co., Ltd.
Unit 301, Tower A, Central Towers, 555 Langao Road, Putuo District, Shanghai, 200333 P. R. China
Tel: +86-21-2226-0888, Fax: +86-21-2226-0999

Renesas Electronics Hong Kong Limited
Unit 1601-1611, 16/F., Tower 2, Grand Century Place, 193 Prince Edward Road West, Mongkok, Kowloon, Hong Kong
Tel: +852-2265-6688, Fax: +852-2886-9022

Renesas Electronics Taiwan Co., Ltd.
13F, No. 363, Fu Shing North Road, Taipei 10543, Taiwan
Tel: +886-2-8175-9600, Fax: +886-2-8175-9670

Renesas Electronics Singapore Pte. Ltd.
80 Bendemeer Road, Unit #06-02 Hyflux Innovation Centre, Singapore 339949
Tel: +65-6213-0200, Fax: +65-6213-0300

Renesas Electronics Malaysia Sdn.Bhd.
Unit 1207, Block B, Menara Amcorp, Amcorp Trade Centre, No. 18, Jln Persiaran Barat, 46050 Petaling Jaya, Selangor Darul Ehsan, Malaysia
Tel: +60-3-7955-9390, Fax: +60-3-7955-9510

Renesas Electronics India Pvt. Ltd.
No.777C, 100 Feet Road, HAL 2nd Stage, Indiranagar, Bangalore 560 038, India
Tel: +91-80-67208700, Fax: +91-80-67208777

Renesas Electronics Korea Co., Ltd.
17F, KAMCO Yangjae Tower, 262, Gangnam-daero, Gangnam-gu, Seoul, 06265 Korea
Tel: +82-2-558-3737, Fax: +82-2-558-5338