

Accelerators (IIRFA/TFU) performance in motor application

RA Family

Abstract

The purpose of this application note is to explain how to use IIRFA and TFU and how to reduce processing time when used.

Operation checking device

Operations of the target software of this application note are checked by using the following device.

IIRFA/TFU

- RA6T2 (R7FA6T2BD3CFP)

TFU only

- RA4T1 (R7FA4T1BB3CFM)

- RA6T3 (R7FA6T3BB3CFM)

Contents

1. Overview	3
2. Development environment.....	3
3. Software	4
3.1 Specifications	4
3.2 Sample Program Structure.....	5
3.3 Project Structure.....	5
3.4 Processing of Measured Targets	6
3.4.1 Filter processing for IIRFA measurement (notch filter, LPF).....	6
3.4.2 Processing for TFU measurement (dq conversion)	6
3.5 Selection of measurement Target	7
3.6 Starting measurements	7
3.7 Measurement Processing.....	8
3.8 Peripheral Functions.....	9
3.8.1 IIRFA	9
3.8.2 TFU.....	12
3.8.3 GPT	12
3.8.4 AGT	13
4. Measurement procedure.....	14
4.1 Importing the Demo Project.....	14
4.2 TFU.....	16

Accelerators (IIRFA/TFU) performance in motor application	RA Family
4.3 Build and Download.....	16
4.4 RMW connections	17
4.5 Performing Measurements	18
4.5.1 Selection of measurement target	18
4.5.2 Start of measurement.....	19
4.5.3 Confirmation of measurement results	19
4.6 Measurement results	21
5. Reference Documents	23
Revision History	24

1. Overview

This application note shows the effect of IIRFA and TFU to reduce processing time. Sample code with IIRFA and TFU and sample code written in c language without them are used to check the processing time.

2. Development environment

Table 2-1 and Table 2-2 show development environment of the software explained in this application note.

Table 2-1 Hardware Development Environment

Microcontroller	Evaluation board
RA6T2 (R7FA6T2BD3CFP)	RA6T2 (R7FA6T2BD3CFP) / RTK0EMA270C00000BJ
RA4T1 (R7FA4T1BB3CFM)	RA4T1 (R7FA4T1BB3CFM) / RTK0EMA430C00000BJ
RA6T3 (R7FA6T3BB3CFM)	RA6T3 (R7FA6T3BB3CFM) / RTK0EMA330C00000BJ

Table 2-2 Software Development Environment

e ² studio version	FSP version	Toolchain version
V2023-04	V4.4.0	GCC ARM Embedded: V10.3.1.20210824

For purchase and technical support, please contact Sales representatives and dealers of Renesas Electronics Corporation.

3. Software

Sample software is described below.

IIRFA is not implemented in RA4T1 and RA6T3. Therefore, the explanation about IIRFA is valid only to RA6T2.

3.1 Specifications

IIRFA processing time is measured with filter processing (5-stage notch filter, 1-stage notch filter, and 2nd-order low-pass filter). In the case where IIRFA is not used, the process is implemented with four arithmetic operations in c code.

TFU processing time is measured with the dq conversion process used in vector control.

The following table summarizes the functions of this sample program.

Table 3-1 List of Functions

Item	Description
Start measurement	Starts measurement triggered by writing "1" to the measurement start variable from RMW
Measurement Function	Measurement using GPT
Filter processing for IIRFA measurement	5-stage notch filter 1-stage notch filter Second-order low-pass filter
Processing for TFU measurement	dq transform in vector control
Setting to the IIRFA input register	Set using FSP API (R_IIRFA_Filter) Directly set to register
Enabling/disabling of IIRFA/TFU	[IIRFA] Measurements when IIRFA is not used are performed by quadrature with c-code. [TFU] Enable/disable with compile option
Switching of measurement target	Filters (3 types) for IIRFA measurement and TFU are switched by RMW operation

3.2 Sample Program Structure

Each CPU board is a target of this sample program. This program measures the processing time of IIRFA and TFU with GPT.

An overall diagram is shown below.

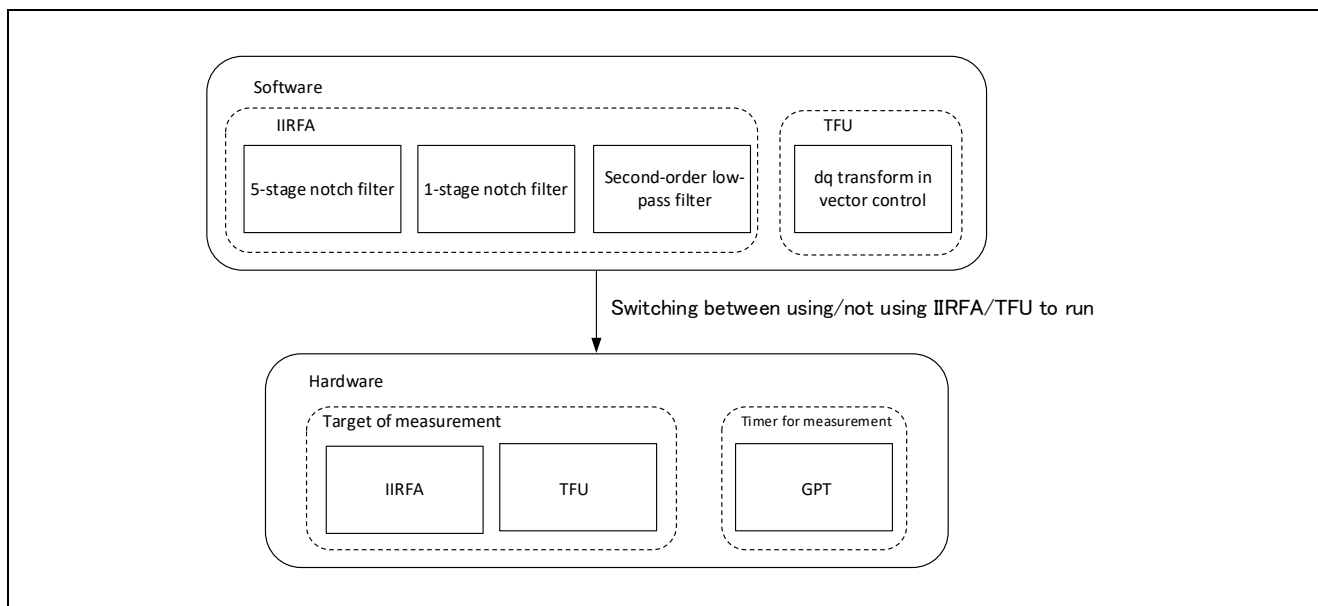

Figure 3-1 Program Structure

3.3 Project Structure

The structure in the project folder of the sample program is shown below.

Table 3-2 Project Structure

Folder	Description
ra_cfg	(Auto-generated) configuration file
ra_gen	(Auto-generated) Register set values, initial values of instance members
ra	(Auto-generated) FSP source code
src	Measurement target/measurement process

The file structure in the src folder is shown below.

Table 3-3 File Structure

File	Description
iir_tfu_main.c	Sample program source code file
iir_tfu_main.h	Sample program header file

3.4 Processing of Measured Targets

3.4.1 Filter processing for IIRFA measurement (notch filter, LPF)

The processing time of IIRFA is measured as a notch filter or second-order low-pass filter.

The notch filter consists of the following transfer functions.

$$\frac{(s^2 + \frac{\omega_n s}{Q_2} + \omega_n^2)}{(s^2 + \frac{\omega_n s}{Q_1} + \omega_n^2)}$$

The second-order low-pass filter consists of the following transfer functions.

$$\frac{\omega_n^2}{s^2 + 2\omega_n \zeta_n s + \omega_n^2}$$

These operations during filter processing are performed by four arithmetic operations using IIRFA and c code.

3.4.2 Processing for TFU measurement (dq conversion)

The processing time of TFU is measured as the dq conversion process in vector control.

The dq transformation is calculated by the following transformation formula.

$$C = \sqrt{\frac{2}{3}} \begin{bmatrix} \cos\theta & \cos(\theta - 2\pi/3) & \cos(\theta + 2\pi/3) \\ -\sin\theta & -\sin(\theta - 2\pi/3) & -\sin(\theta + 2\pi/3) \end{bmatrix}$$

$$\begin{bmatrix} v_d \\ v_q \end{bmatrix} = C \begin{bmatrix} v_u \\ v_v \\ v_w \end{bmatrix}$$

The sin and cos operations during this conversion are performed in each cases of TFU enable or disable.

3.5 Selection of measurement Target

Variables to select the measurement target are listed below.

Table 3-4 Variables for selecting measurement targets

Item	Type	Variable name	Description
Variables for selecting measurement targets	uint8_t	g_u1_measure_select	0: IIRFA 5-stage notch filter 1: IIRFA 1-stage notch filter 2: IIRFA 2nd order low-pass filter 3: TFU dq conversion

The executable process is selected according to the value of g_u1_measure_select.

3.6 Starting measurements

Variables for starting measurements are listed below.

Table 3-5 Variables for starting measurement

Item	Type	Variable name	Description
Variables for starting measurement	uint8_t	g_u1_measure_start	0 : Standby/Stopped measurement 1: Measurement started

'g_u1_measure_start' is monitored in the main loop to move from the wait state to the measurement process.

3.7 Measurement Processing

The count of free-run timer is read at the beginning and ending of the process. From the difference of these counts and timer clock frequency, the processing time is calculated.

Variables for measurement are shown below.

Table 3-6 Variables for measurement

Item	Type	Variable name	Description
At the start of measurement	uint32_t	g_u4_gpt_count_s	Stores timer count value at the start of measurement
At the end of measurement	uint32_t	g_u4_gpt_count_e	Stores timer count value at the end of measurement
Measured value	float	g_f4_measure_iir_api	Stores the processing time calculation value when using IIRFA (API)
	float	g_f4_measure_iir_direct	Stores the processing time calculation value when IIRFA (register direct) is used.
	float	g_f4_measure_iir_non	Stores the processing time calculation value when IIRFA is not used
	float	g_f4_measure_dq	Stores the processing time calculation value of dq conversion

The processing time is calculated as follows

$$\text{Processing time } [\mu\text{s}] = (\text{count at end of measurement} - \text{count at start of measurement}) / \text{GPT clock } [\text{MHz}].$$

3.8 Peripheral Functions

The following table shows used peripheral functions.

Table 3-7 Peripheral Functions

Peripheral	Resource	Description
IIRFA	Channel 0, 1, 2	Used for notch filter and second-order low-pass filter operations.
TFU	-	Used to calculate the sine (sin) and cosine (cos) in a dq conversion
GPT	Channel 0	Used as a free-run timer to measure processing time
AGT	AGT0	250[μs] interval timer

The following is a diagram of the entire FSP stack.

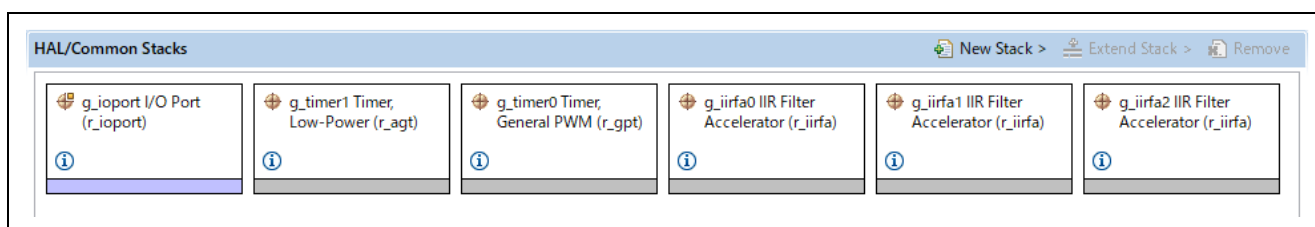

Figure 3-2 Overall view of FSP stack

3.8.1 IIRFA

3.8.1.1 Configuration

Filter processing is performed as a 5-stage notch filter (stages 0-4), a 1-stage notch filter (stage 5), and a 2nd-order low-pass filter (stage 6).

g_iirfa0 IIR Filter Accelerator (r_iirfa)		
Settings	Property	Value
API Info	▼ Common	
	Parameter Checking	Default (BSP)
	Polling Mode	Enabled
	Software Loop Unroll Depth	1 Sample
	ECC Support	Enabled
	Rounding Mode	Nearest
	▼ Module g_iirfa0 IIR Filter Accelerator (r_iirfa)	
	Name	g_iirfa0
	Channel	0

Figure 3-3 FSP configuration for IIRFA

3.8.1.2 IIRFA Filter parameter settings

IIRFA filter configuration is done by setting values in the `iir_filter_cfg_t` structure and using `R_IIRFA_Configure()`.

`R_IIRFA_Configure()` takes `iir_filter_cfg_t` as its argument, and the following settings are used.

· Notch filter

Table 3-8 Notch filter settings

Structure	Member	Value	
iir_filter_cfg_t	iir_filter_coefs_t	b0	0.9349
		b1	-1.78
		b2	0.9281
		a1	1.78
		a2	-0.863
	stage_base	0	
	stage_num	5-stages: 5 1-stage: 1	

· Second-order low-pass filter

Table 3-9 Second-order low-pass filter settings

Structure	Member	Value	
iir_filter_cfg_t	iir_filter_coefs_t	b0	0.37334
		b1	2×0.37334
		b2	0.37334
		a1	-0.37334×1.1894
		a2	-0.37334×0.13205
	stage_base	5	
	stage_num	1	

3.8.1.3 C language Filter parameter settings

The filter coefficients for implementation by C source should be set as follows.

- Notch filter

Table 3-10 Notch filter settings

Coefficient name	Value
ka	0.9349
kb	-1.78
kc	0.9281
kd	-0.863

- Second-order low-pass filter

Table 3-11 Second-order low-pass filter settings

Coefficient name	Value
ka	0.37334
kb	1.1894
kc	0.13205

3.8.1.4 Method of setting input data

For setting input data to IIRFA, two kinds of method can be used to input data into IIRFA (API used or not used).

Table 3-12 Setting Input Data

Item	Description
API Used	Data set using R_IIRFA_Filter() (R_IIRFA_Filter() sets a pointer to the input data variable as an argument)
API not used	Direct data set in R_IIRFA->IIRCH[g_iirfa0_ctrl.channel].INP (Write input data value to the above register)

3.8.2 TFU

TFU is used for trigonometric operations (sine, cosine) in dq conversion.

MCK-RA6T2		
Settings	Property	Value
	> R7FA6T2BD3CFP	
	> RA6T2	
	▼ RA6T2 Family	
	> Security	
	> OFS0 register settings	
	> OFS1 register settings	
	> Block Protection Settings (BPS)	
	> Permanent Block Protection Settings (PBPS)	
	> Clocks	
	Startup C-Cache Line Size	32 Bytes
	TFU Mathlib	Enabled
	Main Oscillator Wait Time	8163 cycles
	> RA Common	

Figure 3-4 TFU enable/disable setting

3.8.3 GPT

GPT is used for a free-run timer to measure processing time.

g_timer0 Timer, General PWM (r_gpt)		
Settings	Property	Value
API Info	▼ Common	
	Parameter Checking	Default (BSP)
	Pin Output Support	Disabled
	Write Protect Enable	Disabled
	Clock Source	PCLKD
	▼ Module g_timer0 Timer, General PWM (r_gpt)	
	▼ General	
	Name	g_timer0
	Channel	0
	Mode	Periodic
	Period	0x10000000
	Period Unit	Raw Counts
	> Output	
	> Input	
	> Interrupts	
	> Extra Features	
	▼ Pins	
	GTIOC0A	<unavailable>
	GTIOC0B	<unavailable>

Figure 3-5 FSP configuration for GPT

3.8.4 AGT

AGT is used as interval timer for processing RMW communication.

g_timer1 Timer, Low-Power (r_agt)		
Settings	Property	Value
API Info	<ul style="list-style-type: none"> ▼ Common Parameter Checking Pin Output Support Pin Input Support ▼ Module g_timer1 Timer, Low-Power (r_agt) <ul style="list-style-type: none"> ▼ General Name Channel Mode Period Period Unit Count Source > Output > Input > Interrupts ▼ Pins AGTEE0 AGTIO0 AGTO0 AGTOA0 AGTOB0 	<ul style="list-style-type: none"> Default (BSP) Disabled Disabled g_timer1 0 Periodic 250 Microseconds PCLKB <unavailable> <unavailable> <unavailable> <unavailable> <unavailable>

Figure 3-6 FSP configuration for AGT

4. Measurement procedure

This section describes the procedure for measuring processing time.

4.1 Importing the Demo Project

The sample application provided with this document may be imported into e²studio using the steps in this section.

- 1) Select File → Import.

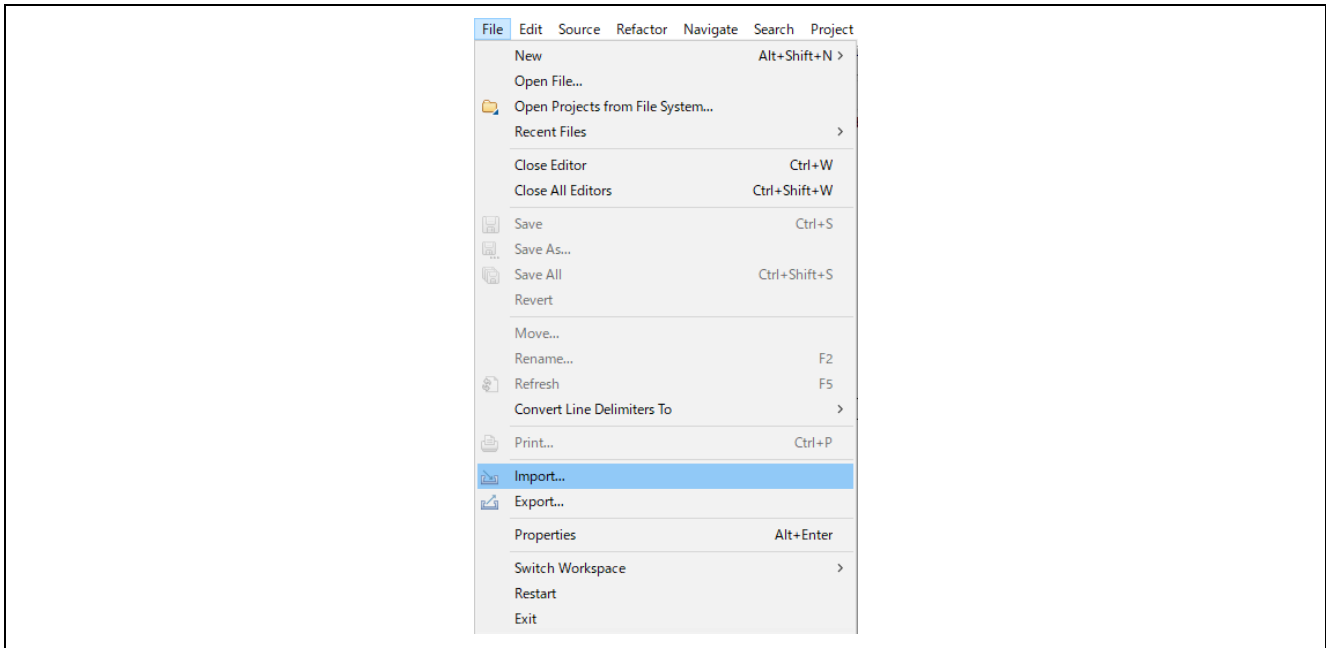

Figure 4-1 File Menu

2) Select “Existing Projects into Workspace”.

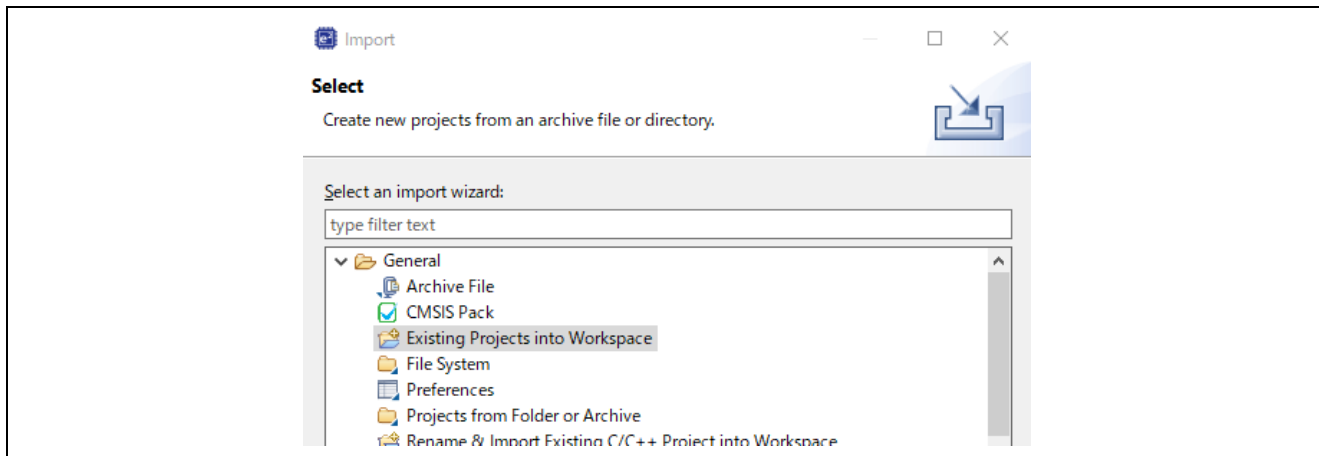

Figure 4-2 Import Wizard Selection

3) input the path.

Click “Browse...” button and select the demo project. Click ‘Finish’ button, then the sample project is imported.

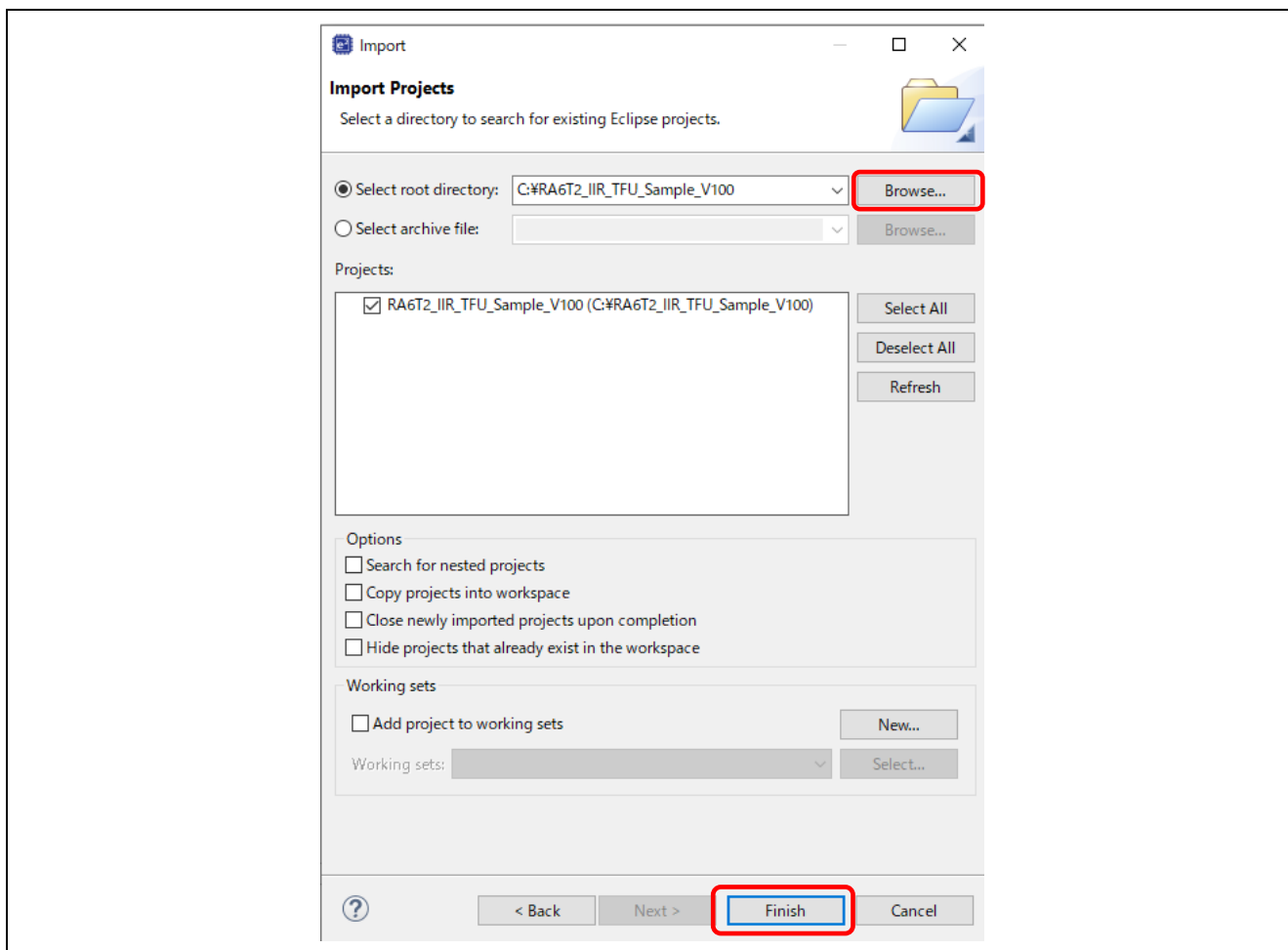

Figure 4-3 Import Projects

4.2 TFU

Enable/Disable TFU.

Select the [BSP] - ["CPU Name" Family] - [TFU Mathlib] setting.

Enable: Enable

Disable: Disable

MCK-RA6T2		
Settings	Property	Value
	> R7FA6T2BD3CFP	
	> RA6T2	
	▼ RA6T2 Family	
	> Security	
	> OFS0 register settings	
	> OFS1 register settings	
	> Block Protection Settings (BPS)	
	> Permanent Block Protection Settings (PBPS)	
	> Clocks	
	Startup C-Cache Line Size	32 Bytes
	TFU Mathlib	Enabled
	Main Oscillator Wait Time	8163 cycles
	> RA Common	

Figure 4-4 Enable/Disable TFU

4.3 Build and Download

Build and download the program.

Refer to the "e²studio Getting Started Guide (R20UT4204)".

4.4 RMW connections

Renesas Motor Workbench, a motor control development support tool, is used as a user interface (for Start of measurement and check of measurement results). Renesas Motor Workbench (RMW) can be downloaded from our website.

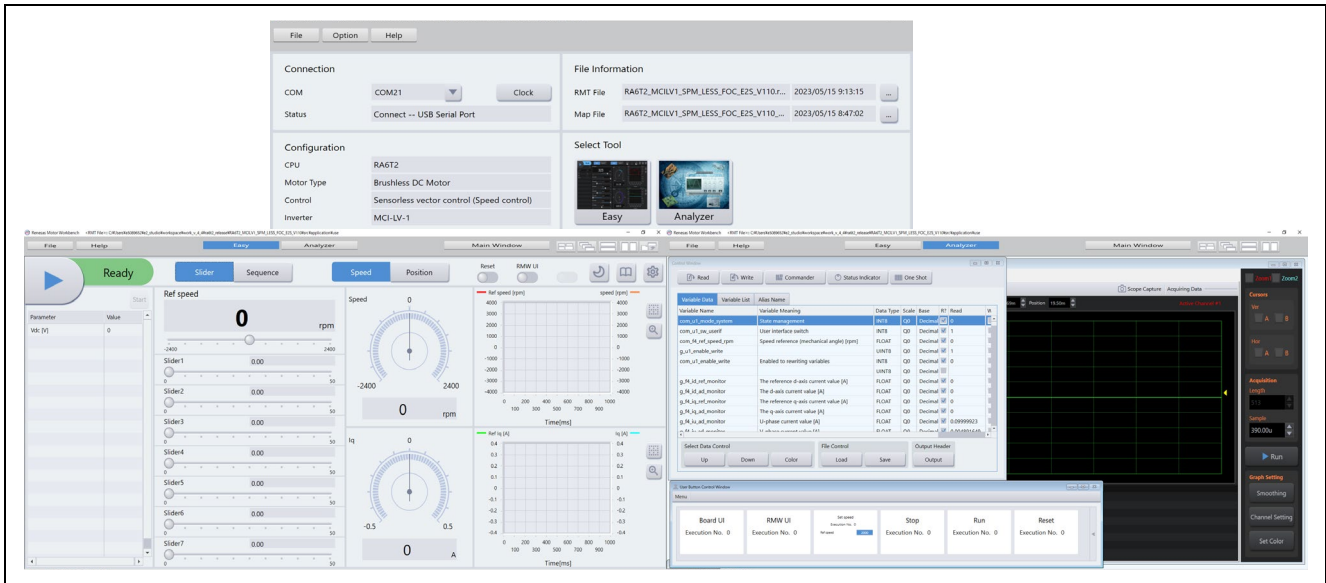
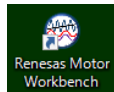
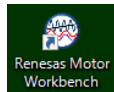

Figure 4-5 Windows of Renesas Motor Workbench

How to use Renesas Motor Workbench (motor control development support tool)



- Click the  icon to start the tool.
- On the menu bar of the Main Window, select [File] > [Open RMT File].
The RMT file in the "rmw" folder in the project folder is loaded.
- In the [Connection] area, from the [COM] drop-down list, select the COM of the connected kit.
- In the [Select Tool] area, click the [Analyzer] button to open the Analyzer Window.

What is the RMT file?

- The RMT file is a file that stores the environmental information that was manipulated or configured by using RMW.
- If the environmental information has been saved in the RMT file, the environment can be restored with the saved information by calling the RMT file.
- If the address information of a program is changed, load the map file that was generated during program building, and then save the RMT file again.

4.5 Performing Measurements

4.5.1 Selection of measurement target

Write defined values for each measurement target into the variable which is provided for measurement target selection from RMW according to the following table.

Variable to select measured target: `g_u1_measure_select`

Table 4-1 Defined value to be measured

No	Target of measurement
0	IIRFA 5-stage notch filter
1	IIRFA 1-stage notch filter
2	IIRFA 2nd order low pass filter
3	TFU dq conversion

(1) Enter the value to be measured in `g_u1_measure_select`

(2) Click "Write"

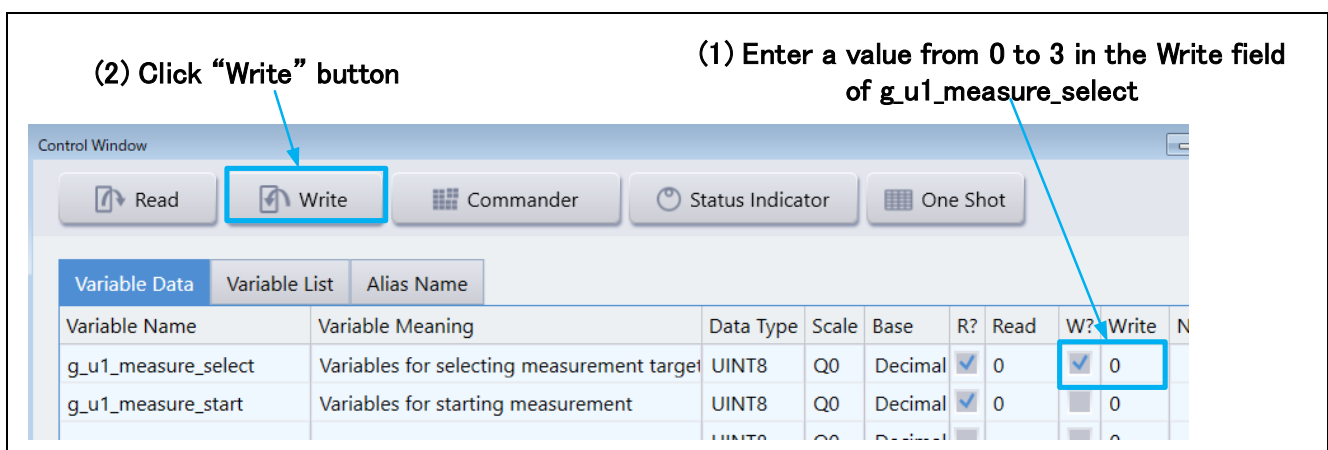

Figure 4-6 Selection of measurement target

4.5.2 Start of measurement

Write "1" to the variable for starting measurement from RMW to start measurement.

Variable for starting measurement: g_u1_measure_start

- (1) Enter 1 in g_u1_measure_start
- (2) Click Write

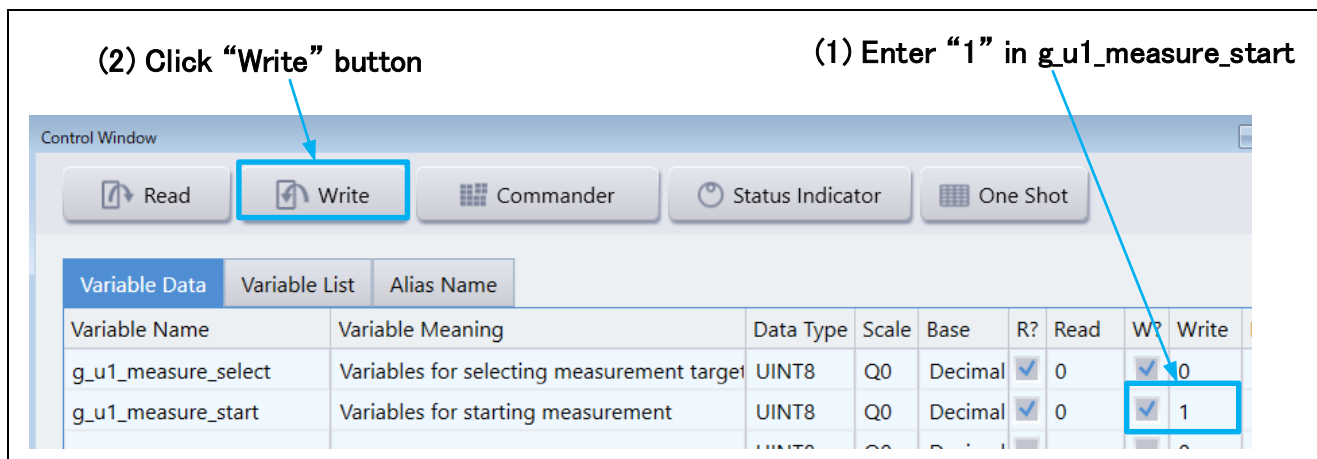

Figure 4-7 Start of measurement

4.5.3 Confirmation of measurement results

Confirm the measurement result (measured period) by reading defined variables as shown below on RMW.

Table 4-2 Variables for measurement

Variables	Discription
g_f4_measure_iir_api	Stores the processing time calculation value [us] when using IIRFA (API)
g_f4_measure_iir_direct	Stores the processing time calculation value [us] when using IIRFA (register direct)
g_f4_measure_iir_non	Stores the processing time calculation value [us] when IIRFA is not used
g_f4_measure_dq	Stores the processing time calculation value [us] of dq conversion

- (1) Click Read
- (2) Confirm the measured value

(1) Click "Read" button

(2) Check each measurement

The screenshot shows a software interface titled "Control Window". At the top, there are several buttons: "Read", "Write", "Commander", "Status Indicator", and "One Shot". The "Read" button is highlighted with a blue box and an arrow pointing to it from the text "(1) Click 'Read' button". Below the buttons is a table with columns for "Variable Name", "Variable Meaning", "Data Type", "Scale", "Base", "R?", "Read", "W?", and "Write". The "Read" column contains numerical values for four variables, and this column is highlighted with a blue box and an arrow pointing to it from the text "(2) Check each measurement".

Variable Name	Variable Meaning	Data Type	Scale	Base	R?	Read	W?	Write
g_f4_measure_iir_api	Stores the processing time calculation valu	FLOAT	Q0	Decimal	<input checked="" type="checkbox"/>	1.058333	<input type="checkbox"/>	0
g_f4_measure_iir_direct	Stores the processing time calculation valu	FLOAT	Q0	Decimal	<input checked="" type="checkbox"/>	0.2416667	<input type="checkbox"/>	0
g_f4_measure_iir_non	Stores the processing time calculation valu	FLOAT	Q0	Decimal	<input checked="" type="checkbox"/>	5.133334	<input type="checkbox"/>	0
g_f4_measure_dq	Stores the processing time calculation valu	FLOAT	Q0	Decimal	<input checked="" type="checkbox"/>	0	<input type="checkbox"/>	0

Figure 4-8 Confirmation of measured values

4.6 Measurement results

Measured results with using the sample program are shown below.

·IIRFA

Table 4-3 Measurement results (IIRFA) [us]

Filter	processing method		
	C source	API Used	API not used
5-stage notch filter	5.13	1.06	0.24
1-stage notch filter	1.23	0.95	0.22
2nd order low-pass filter	0.71	0.95	0.22

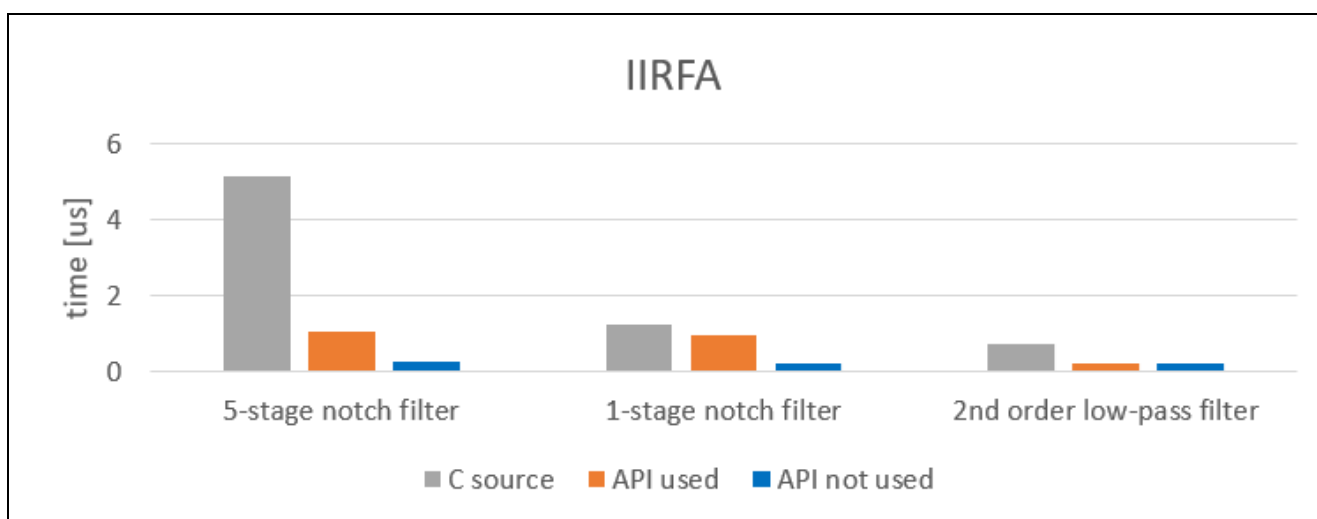
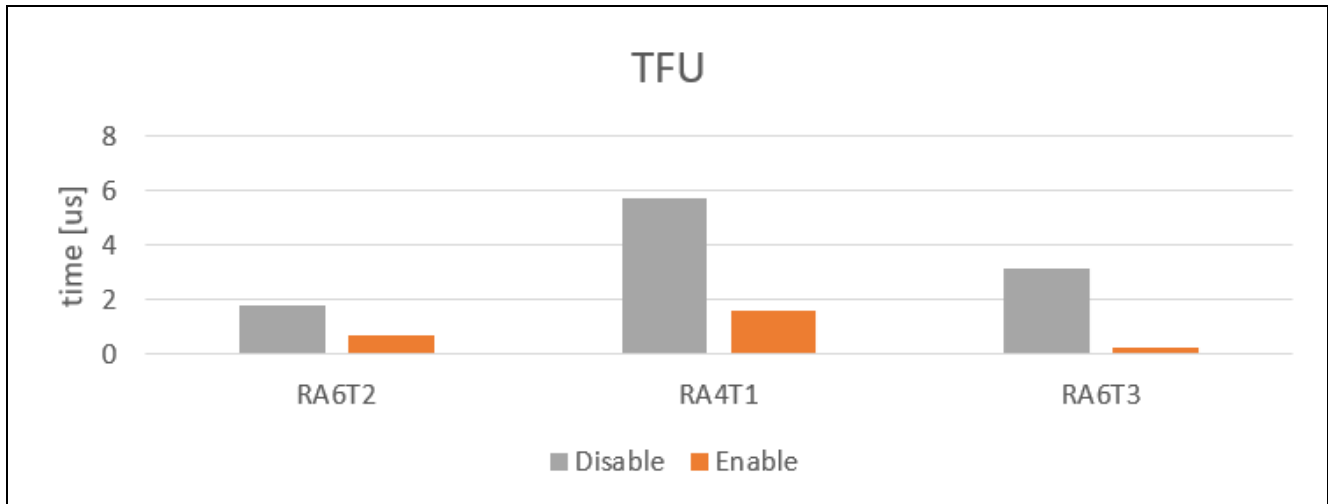

Figure 4-9 Measurement results (IIRFA)

·TFU

Table 4-4 Measurement results (TFU) [us]

Measured target	Target MCU	TFU disabled	TFU enabled
dq transformation	RA6T2	1.78	0.71
	RA4T1	5.74	1.63
	RA6T3	3.17	0.92

**Figure 4-10 Measurement results (TFU)**

5. Reference Documents

RA6T2 Group User's Manual: Hardware (R01UH0951)
RA4T1 Group User's Manual: Hardware (R01UH0999)
RA6T3 Group User's Manual: Hardware (R01UH0998)
RA Flexible Software Package Documentation
Renesas Motor Workbench User's Manual (R21UZ0004)
Renesas Motor Workbench Quick start guide (R21QS0011)
MCK-RA6T2 User's Manual (R12UZ0091)
MCK-RA4T1 User's Manual (R12UZ0117)
MCK-RA6T3 User's Manual (R12UZ0116)

Revision History

Rev.	Date	Description	
		Page	Summary
1.00	May 23, 2023	-	First edition issued

General Precautions in the Handling of Microprocessing Unit and Microcontroller Unit Products

The following usage notes are applicable to all Microprocessing unit and Microcontroller unit products from Renesas. For detailed usage notes on the products covered by this document, refer to the relevant sections of the document as well as any technical updates that have been issued for the products.

1. Precaution against Electrostatic Discharge (ESD)

A strong electrical field, when exposed to a CMOS device, can cause destruction of the gate oxide and ultimately degrade the device operation. Steps must be taken to stop the generation of static electricity as much as possible, and quickly dissipate it when it occurs. Environmental control must be adequate. When it is dry, a humidifier should be used. This is recommended to avoid using insulators that can easily build up static electricity. Semiconductor devices must be stored and transported in an anti-static container, static shielding bag or conductive material. All test and measurement tools including work benches and floors must be grounded. The operator must also be grounded using a wrist strap. Semiconductor devices must not be touched with bare hands. Similar precautions must be taken for printed circuit boards with mounted semiconductor devices.

2. Processing at power-on

The state of the product is undefined at the time when power is supplied. The states of internal circuits in the LSI are indeterminate and the states of register settings and pins are undefined at the time when power is supplied. In a finished product where the reset signal is applied to the external reset pin, the states of pins are not guaranteed from the time when power is supplied until the reset process is completed. In a similar way, the states of pins in a product that is reset by an on-chip power-on reset function are not guaranteed from the time when power is supplied until the power reaches the level at which resetting is specified.

3. Input of signal during power-off state

Do not input signals or an I/O pull-up power supply while the device is powered off. The current injection that results from input of such a signal or I/O pull-up power supply may cause malfunction and the abnormal current that passes in the device at this time may cause degradation of internal elements. Follow the guideline for input signal during power-off state as described in your product documentation.

4. Handling of unused pins

Handle unused pins in accordance with the directions given under handling of unused pins in the manual. The input pins of CMOS products are generally in the high-impedance state. In operation with an unused pin in the open-circuit state, extra electromagnetic noise is induced in the vicinity of the LSI, an associated shoot-through current flows internally, and malfunctions occur due to the false recognition of the pin state as an input signal become possible.

5. Clock signals

After applying a reset, only release the reset line after the operating clock signal becomes stable. When switching the clock signal during program execution, wait until the target clock signal is stabilized. When the clock signal is generated with an external resonator or from an external oscillator during a reset, ensure that the reset line is only released after full stabilization of the clock signal. Additionally, when switching to a clock signal produced with an external resonator or by an external oscillator while program execution is in progress, wait until the target clock signal is stable.

6. Voltage application waveform at input pin

Waveform distortion due to input noise or a reflected wave may cause malfunction. If the input of the CMOS device stays in the area between V_{IL} (Max.) and V_{IH} (Min.) due to noise, for example, the device may malfunction. Take care to prevent chattering noise from entering the device when the input level is fixed, and also in the transition period when the input level passes through the area between V_{IL} (Max.) and V_{IH} (Min.).

7. Prohibition of access to reserved addresses

Access to reserved addresses is prohibited. The reserved addresses are provided for possible future expansion of functions. Do not access these addresses as the correct operation of the LSI is not guaranteed.

8. Differences between products

Before changing from one product to another, for example to a product with a different part number, confirm that the change will not lead to problems. The characteristics of a microprocessing unit or microcontroller unit products in the same group but having a different part number might differ in terms of internal memory capacity, layout pattern, and other factors, which can affect the ranges of electrical characteristics, such as characteristic values, operating margins, immunity to noise, and amount of radiated noise. When changing to a product with a different part number, implement a system-evaluation test for the given product.

Notice

1. Descriptions of circuits, software and other related information in this document are provided only to illustrate the operation of semiconductor products and application examples. You are fully responsible for the incorporation or any other use of the circuits, software, and information in the design of your product or system. Renesas Electronics disclaims any and all liability for any losses and damages incurred by you or third parties arising from the use of these circuits, software, or information.
2. Renesas Electronics hereby expressly disclaims any warranties against and liability for infringement or any other claims involving patents, copyrights, or other intellectual property rights of third parties, by or arising from the use of Renesas Electronics products or technical information described in this document, including but not limited to, the product data, drawings, charts, programs, algorithms, and application examples.
3. No license, express, implied or otherwise, is granted hereby under any patents, copyrights or other intellectual property rights of Renesas Electronics or others.
4. You shall be responsible for determining what licenses are required from any third parties, and obtaining such licenses for the lawful import, export, manufacture, sales, utilization, distribution or other disposal of any products incorporating Renesas Electronics products, if required.
5. You shall not alter, modify, copy, or reverse engineer any Renesas Electronics product, whether in whole or in part. Renesas Electronics disclaims any and all liability for any losses or damages incurred by you or third parties arising from such alteration, modification, copying or reverse engineering.
6. Renesas Electronics products are classified according to the following two quality grades: "Standard" and "High Quality". The intended applications for each Renesas Electronics product depends on the product's quality grade, as indicated below.

"Standard": Computers; office equipment; communications equipment; test and measurement equipment; audio and visual equipment; home electronic appliances; machine tools; personal electronic equipment; industrial robots; etc.

"High Quality": Transportation equipment (automobiles, trains, ships, etc.); traffic control (traffic lights); large-scale communication equipment; key financial terminal systems; safety control equipment; etc.

Unless expressly designated as a high reliability product or a product for harsh environments in a Renesas Electronics data sheet or other Renesas Electronics document, Renesas Electronics products are not intended or authorized for use in products or systems that may pose a direct threat to human life or bodily injury (artificial life support devices or systems; surgical implantations; etc.), or may cause serious property damage (space system; undersea repeaters; nuclear power control systems; aircraft control systems; key plant systems; military equipment; etc.). Renesas Electronics disclaims any and all liability for any damages or losses incurred by you or any third parties arising from the use of any Renesas Electronics product that is inconsistent with any Renesas Electronics data sheet, user's manual or other Renesas Electronics document.

7. No semiconductor product is absolutely secure. Notwithstanding any security measures or features that may be implemented in Renesas Electronics hardware or software products, Renesas Electronics shall have absolutely no liability arising out of any vulnerability or security breach, including but not limited to any unauthorized access to or use of a Renesas Electronics product or a system that uses a Renesas Electronics product. RENESAS ELECTRONICS DOES NOT WARRANT OR GUARANTEE THAT RENESAS ELECTRONICS PRODUCTS, OR ANY SYSTEMS CREATED USING RENESAS ELECTRONICS PRODUCTS WILL BE INVULNERABLE OR FREE FROM CORRUPTION, ATTACK, VIRUSES, INTERFERENCE, HACKING, DATA LOSS OR THEFT, OR OTHER SECURITY INTRUSION ("Vulnerability Issues"). RENESAS ELECTRONICS DISCLAIMS ANY AND ALL RESPONSIBILITY OR LIABILITY ARISING FROM OR RELATED TO ANY VULNERABILITY ISSUES. FURTHERMORE, TO THE EXTENT PERMITTED BY APPLICABLE LAW, RENESAS ELECTRONICS DISCLAIMS ANY AND ALL WARRANTIES, EXPRESS OR IMPLIED, WITH RESPECT TO THIS DOCUMENT AND ANY RELATED OR ACCOMPANYING SOFTWARE OR HARDWARE, INCLUDING BUT NOT LIMITED TO THE IMPLIED WARRANTIES OF MERCHANTABILITY, OR FITNESS FOR A PARTICULAR PURPOSE.
8. When using Renesas Electronics products, refer to the latest product information (data sheets, user's manuals, application notes, "General Notes for Handling and Using Semiconductor Devices" in the reliability handbook, etc.), and ensure that usage conditions are within the ranges specified by Renesas Electronics with respect to maximum ratings, operating power supply voltage range, heat dissipation characteristics, installation, etc. Renesas Electronics disclaims any and all liability for any malfunctions, failure or accident arising out of the use of Renesas Electronics products outside of such specified ranges.
9. Although Renesas Electronics endeavors to improve the quality and reliability of Renesas Electronics products, semiconductor products have specific characteristics, such as the occurrence of failure at a certain rate and malfunctions under certain use conditions. Unless designated as a high reliability product or a product for harsh environments in a Renesas Electronics data sheet or other Renesas Electronics document, Renesas Electronics products are not subject to radiation resistance design. You are responsible for implementing safety measures to guard against the possibility of bodily injury, injury or damage caused by fire, and/or danger to the public in the event of a failure or malfunction of Renesas Electronics products, such as safety design for hardware and software, including but not limited to redundancy, fire control and malfunction prevention, appropriate treatment for aging degradation or any other appropriate measures. Because the evaluation of microcomputer software alone is very difficult and impractical, you are responsible for evaluating the safety of the final products or systems manufactured by you.
10. Please contact a Renesas Electronics sales office for details as to environmental matters such as the environmental compatibility of each Renesas Electronics product. You are responsible for carefully and sufficiently investigating applicable laws and regulations that regulate the inclusion or use of controlled substances, including without limitation, the EU RoHS Directive, and using Renesas Electronics products in compliance with all these applicable laws and regulations. Renesas Electronics disclaims any and all liability for damages or losses occurring as a result of your noncompliance with applicable laws and regulations.
11. Renesas Electronics products and technologies shall not be used for or incorporated into any products or systems whose manufacture, use, or sale is prohibited under any applicable domestic or foreign laws or regulations. You shall comply with any applicable export control laws and regulations promulgated and administered by the governments of any countries asserting jurisdiction over the parties or transactions.
12. It is the responsibility of the buyer or distributor of Renesas Electronics products, or any other party who distributes, disposes of, or otherwise sells or transfers the product to a third party, to notify such third party in advance of the contents and conditions set forth in this document.
13. This document shall not be reprinted, reproduced or duplicated in any form, in whole or in part, without prior written consent of Renesas Electronics.
14. Please contact a Renesas Electronics sales office if you have any questions regarding the information contained in this document or Renesas Electronics products.

(Note1) "Renesas Electronics" as used in this document means Renesas Electronics Corporation and also includes its directly or indirectly controlled subsidiaries.

(Note2) "Renesas Electronics product(s)" means any product developed or manufactured by or for Renesas Electronics.

(Rev.5.0-1 October 2020)

Corporate Headquarters

TOYOSU FORESIA, 3-2-24 Toyosu,
Koto-ku, Tokyo 135-0061, Japan

www.renesas.com

Trademarks

Renesas and the Renesas logo are trademarks of Renesas Electronics Corporation. All trademarks and registered trademarks are the property of their respective owners.

Contact information

For further information on a product, technology, the most up-to-date version of a document, or your nearest sales office, please visit:

www.renesas.com/contact/.