

Introduction

This application note describes the requirements for a differential interface being referenced to the V_{IH} (Input High Voltage) of an input signal.

Advantages of a Differential Interface

- It offers a wide range of input signaling standards and works with a wide range of input offset voltage.
- Greater immunity to common mode noise. Has tolerance to ground offsets or noise.
- Suitability for use with a low voltage application.
- Less power and substrate noise during signal transition. Current switching much less than single ended interface.
- Reduced EMI due to the cancellation in differential traces.

Requirements of Differential Interface

The input requirement for a differential interface is different from the requirement for a single ended interface. In a single ended interface such as LVCMOS, LVTTTL, single-ended HSTL or single-ended PECL/ECL, the V_{OH} and V_{OL} must meet the V_{IH} and V_{IL} requirements of the receivers. In the differential interface, such as LVPECL, HSTL, HCSL, CML, LVDS, or SSTL, the V_{IH} and V_{IL} are no longer referenced. The input parameters V_{PP} and V_{CMR} are now the requirements. Only V_{SWING} and the V_{OH} of the incoming signal are required to meet both V_{PP} and V_{CMR} .

$$V_{PP} < V_{SWING} < V_{PP_MAX}$$

$$V_{CMR_MIN} < V_{OH} < V_{CMR_MAX}$$

V_{PP} = Input peak-to-peak voltage requirement

V_{CMR} = Input Common Mode Range Voltage requirement

V_{SWING} = Driver output swing

V_{OH} = Driver output logic high

Figure 1 shows the relationship between V_{SWING} , V_{OH} and V_{PP} , V_{CMR} . The following conditions must be met for a valid input signal: V_{SWING} must be within the required range of the specified V_{PP} and the V_{OH} must be within the V_{CMR} range.

Figure 1. Relationship between Interface Parameters

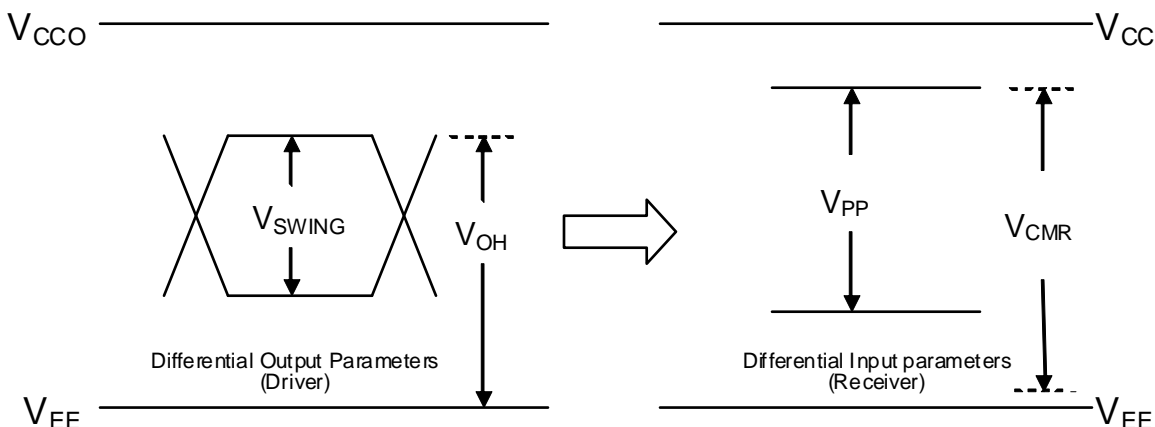

Figure 2. Typical Datasheet for VCMR and VPP

Symbol	Parameter	Minimum	Typical	Maximum	Units
V_{PP}	Peak-to-Peak Input Voltage	0.15		1.3	V
V_{CMR}	Common Mode Input Voltage	$V_{EE} + 0.5$		$V_{CC} - 0.85$	V

Example

Figure 2 shows a typical datasheet specification for both V_{PP} and V_{CMR} . As an example, let's use an input driver with an amplitude (V_{SWING}) of 200mV and a V_{OH} level at 2V. Will this work? First, the V_{SWING} should be verified that it is within the V_{PP} specification. Yes, 200mV falls between 0.15V and 1.3V. Second, the V_{OH} of the signal must fall within the V_{CMR} range. Assuming the V_{CC} is 3.3V and V_{EE} is 0V, the V_{CMR} range will be 0.5V and 2.45V. Again, 2V fall within the V_{CMR} range. Both of the conditions are met. This is a valid input. Though not specified, it is not recommended that the V_{IL} goes below V_{EE} . This could happen with the V_{PP} at 1.3V and the V_{IH} at $V_{EE}+0.5$. That would put the V_{IL} at 800mV below V_{EE} .

Limitations of VCMR and VPP

This section will describe the limitation of both V_{CMR} and v from a circuit perspective. When V_{CMR} is referenced to V_{IH} , the analysis is purely DC. Some inputs also reference V_{CMR} to the input signals cross-point. This would be a similar except it would be an AC analysis.

Figure 3. Simplified Typical Differential Input Interface Circuit

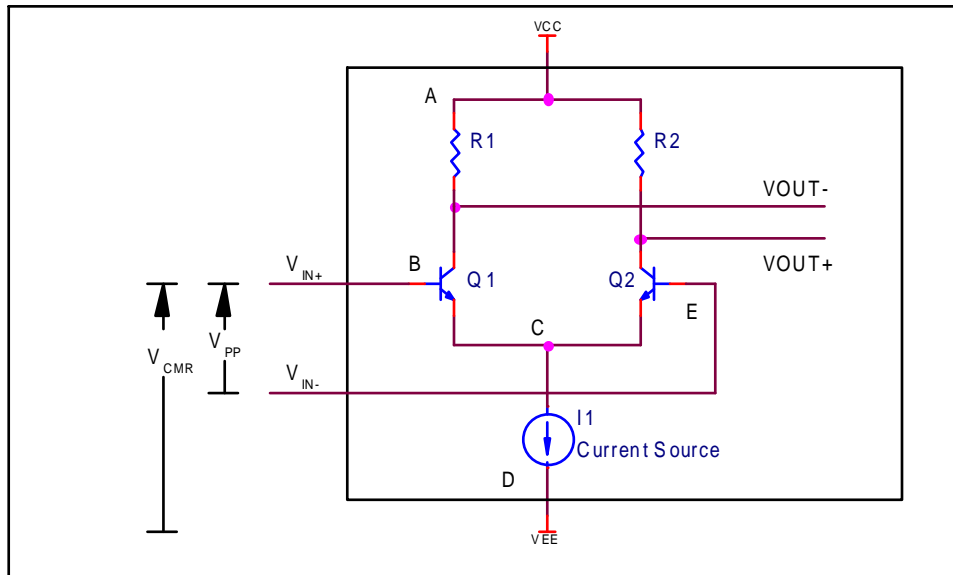

For the following analysis, refer to Figure 3. In determining V_{PP} , both $V_{PP(min)}$ and $V_{PP(max)}$ specification must be examined. For both cases, V_{IN+} is greater than V_{IN-} , where V_{IN+} is a logic high and V_{IN-} is a logic low.

- $V_{PP(min)}$ is determined by the minimum voltage difference required to correctly operate the differential amplifier by keeping the Q1 transistor on and Q2 off.
- $V_{PP(max)}$ is determined by the maximum voltage swing allowable which will not forward bias either Q1 or Q2.

Similar to V_{PP} , both $V_{CMR(max)}$ and $V_{CMR(min)}$ must be examined.

- $V_{CMR(min)}$ is determined by the minimum V_{CD} required to keep the constant current source I1 function properly.
- $V_{CMR(max)}$ is determined by the minimum V_{AB} required to prevent the forward biasing of Q1.

Notice

1. Descriptions of circuits, software and other related information in this document are provided only to illustrate the operation of semiconductor products and application examples. You are fully responsible for the incorporation or any other use of the circuits, software, and information in the design of your product or system. Renesas Electronics disclaims any and all liability for any losses and damages incurred by you or third parties arising from the use of these circuits, software, or information.
2. Renesas Electronics hereby expressly disclaims any warranties against and liability for infringement or any other claims involving patents, copyrights, or other intellectual property rights of third parties, by or arising from the use of Renesas Electronics products or technical information described in this document, including but not limited to, the product data, drawings, charts, programs, algorithms, and application examples.
3. No license, express, implied or otherwise, is granted hereby under any patents, copyrights or other intellectual property rights of Renesas Electronics or others.
4. You shall be responsible for determining what licenses are required from any third parties, and obtaining such licenses for the lawful import, export, manufacture, sales, utilization, distribution or other disposal of any products incorporating Renesas Electronics products, if required.
5. You shall not alter, modify, copy, or reverse engineer any Renesas Electronics product, whether in whole or in part. Renesas Electronics disclaims any and all liability for any losses or damages incurred by you or third parties arising from such alteration, modification, copying or reverse engineering.
6. Renesas Electronics products are classified according to the following two quality grades: "Standard" and "High Quality". The intended applications for each Renesas Electronics product depends on the product's quality grade, as indicated below.

"Standard": Computers; office equipment; communications equipment; test and measurement equipment; audio and visual equipment; home electronic appliances; machine tools; personal electronic equipment; industrial robots; etc.

"High Quality": Transportation equipment (automobiles, trains, ships, etc.); traffic control (traffic lights); large-scale communication equipment; key financial terminal systems; safety control equipment; etc.

Unless expressly designated as a high reliability product or a product for harsh environments in a Renesas Electronics data sheet or other Renesas Electronics document, Renesas Electronics products are not intended or authorized for use in products or systems that may pose a direct threat to human life or bodily injury (artificial life support devices or systems; surgical implantations; etc.), or may cause serious property damage (space system; undersea repeaters; nuclear power control systems; aircraft control systems; key plant systems; military equipment; etc.). Renesas Electronics disclaims any and all liability for any damages or losses incurred by you or any third parties arising from the use of any Renesas Electronics product that is inconsistent with any Renesas Electronics data sheet, user's manual or other Renesas Electronics document.
7. No semiconductor product is absolutely secure. Notwithstanding any security measures or features that may be implemented in Renesas Electronics hardware or software products, Renesas Electronics shall have absolutely no liability arising out of any vulnerability or security breach, including but not limited to any unauthorized access to or use of a Renesas Electronics product or a system that uses a Renesas Electronics product. RENESAS ELECTRONICS DOES NOT WARRANT OR GUARANTEE THAT RENESAS ELECTRONICS PRODUCTS, OR ANY SYSTEMS CREATED USING RENESAS ELECTRONICS PRODUCTS WILL BE INVULNERABLE OR FREE FROM CORRUPTION, ATTACK, VIRUSES, INTERFERENCE, HACKING, DATA LOSS OR THEFT, OR OTHER SECURITY INTRUSION ("Vulnerability Issues"). RENESAS ELECTRONICS DISCLAIMS ANY AND ALL RESPONSIBILITY OR LIABILITY ARISING FROM OR RELATED TO ANY VULNERABILITY ISSUES. FURTHERMORE, TO THE EXTENT PERMITTED BY APPLICABLE LAW, RENESAS ELECTRONICS DISCLAIMS ANY AND ALL WARRANTIES, EXPRESS OR IMPLIED, WITH RESPECT TO THIS DOCUMENT AND ANY RELATED OR ACCOMPANYING SOFTWARE OR HARDWARE, INCLUDING BUT NOT LIMITED TO THE IMPLIED WARRANTIES OF MERCHANTABILITY, OR FITNESS FOR A PARTICULAR PURPOSE.
8. When using Renesas Electronics products, refer to the latest product information (data sheets, user's manuals, application notes, "General Notes for Handling and Using Semiconductor Devices" in the reliability handbook, etc.), and ensure that usage conditions are within the ranges specified by Renesas Electronics with respect to maximum ratings, operating power supply voltage range, heat dissipation characteristics, installation, etc. Renesas Electronics disclaims any and all liability for any malfunctions, failure or accident arising out of the use of Renesas Electronics products outside of such specified ranges.
9. Although Renesas Electronics endeavors to improve the quality and reliability of Renesas Electronics products, semiconductor products have specific characteristics, such as the occurrence of failure at a certain rate and malfunctions under certain use conditions. Unless designated as a high reliability product or a product for harsh environments in a Renesas Electronics data sheet or other Renesas Electronics document, Renesas Electronics products are not subject to radiation resistance design. You are responsible for implementing safety measures to guard against the possibility of bodily injury, injury or damage caused by fire, and/or danger to the public in the event of a failure or malfunction of Renesas Electronics products, such as safety design for hardware and software, including but not limited to redundancy, fire control and malfunction prevention, appropriate treatment for aging degradation or any other appropriate measures. Because the evaluation of microcomputer software alone is very difficult and impractical, you are responsible for evaluating the safety of the final products or systems manufactured by you.
10. Please contact a Renesas Electronics sales office for details as to environmental matters such as the environmental compatibility of each Renesas Electronics product. You are responsible for carefully and sufficiently investigating applicable laws and regulations that regulate the inclusion or use of controlled substances, including without limitation, the EU RoHS Directive, and using Renesas Electronics products in compliance with all these applicable laws and regulations. Renesas Electronics disclaims any and all liability for damages or losses occurring as a result of your noncompliance with applicable laws and regulations.
11. Renesas Electronics products and technologies shall not be used for or incorporated into any products or systems whose manufacture, use, or sale is prohibited under any applicable domestic or foreign laws or regulations. You shall comply with any applicable export control laws and regulations promulgated and administered by the governments of any countries asserting jurisdiction over the parties or transactions.
12. It is the responsibility of the buyer or distributor of Renesas Electronics products, or any other party who distributes, disposes of, or otherwise sells or transfers the product to a third party, to notify such third party in advance of the contents and conditions set forth in this document.
13. This document shall not be reprinted, reproduced or duplicated in any form, in whole or in part, without prior written consent of Renesas Electronics.
14. Please contact a Renesas Electronics sales office if you have any questions regarding the information contained in this document or Renesas Electronics products.

(Note1) "Renesas Electronics" as used in this document means Renesas Electronics Corporation and also includes its directly or indirectly controlled subsidiaries.

(Note2) "Renesas Electronics product(s)" means any product developed or manufactured by or for Renesas Electronics.

(Disclaimer Rev.5.0-1)

Corporate Headquarters

TOYOSU FORESIA, 3-2-24 Toyosu,
Koto-ku, Tokyo 135-0061, Japan
www.renesas.com

Trademarks

Renesas and the Renesas logo are trademarks of Renesas Electronics Corporation. All trademarks and registered trademarks are the property of their respective owners.

Contact Information

For further information on a product, technology, the most up-to-date version of a document, or your nearest sales office, please visit:
www.renesas.com/contact/