

Introduction

This application note explains the mounting and heat dissipation requirements of the TO-247plus package.

Contents

- 1. Outline.....2
- 2. Package Size .....3
- 3. Heat Dissipation Characteristics .....4
  - 3.1 Mounting Torque (contact pressure).....4
  - 3.2 Thermal Grease .....4
  - 3.3 Comparison with TO-247 .....5
- 4. Usage Notes for Mounting and Storage.....5
  - 4.1 Device Holding Position during Heatsink Mounting .....5
  - 4.2 Forming and Cutting Leads.....6
  - 4.3 Storage.....7
    - 4.3.1 Storage Environment .....7
    - 4.3.2 Storage form .....8
    - 4.3.3 Long Term Storage .....8

## 1. Outline

Multiple IGBTs are used in parallel connection to increase the power of a system and reduce conduction loss. Yet we now see a growing need to use IGBTs with a high rated current to reduce the number of parallel connections or to further increase the power of the system.

The most common method of improving the rated current of the IGBT is to mount larger chips on the package, but each package has physical restrictions in regards to what size chip can be mounted.

As a solution, the TO-247plus package offers the same shape as that of the conventional TO-247 package, while the rated current has been improved by eliminating screw holes and mounting a larger chip. At the same time, the heat dissipation performance is also improved by the area expansion effect of the backside (collector electrode), the contact point for the heat sink. These effects make it possible to increase the power of the system with fewer parallel connections.

Screw holes were eliminated by attaching the TO-247plus package to the heat sink with a clip rather than conventional screw fastenings.

Please notice heatsink mounting. Because of inappropriate mounting, heat dissipation is not enough, and device temperature might increase beyond expectation.

## 2. Package Size

The following illustrates the package sizes of the TO-247 and TO-247plus.

The most difference between the two package types is the presence, or lack of, screw holes. External dimensions, pin pitch and other features remain almost same. Board design for TO-247plus can incorporate the same pattern used for the TO-247, with easy replacement evaluation.

Unit: mm

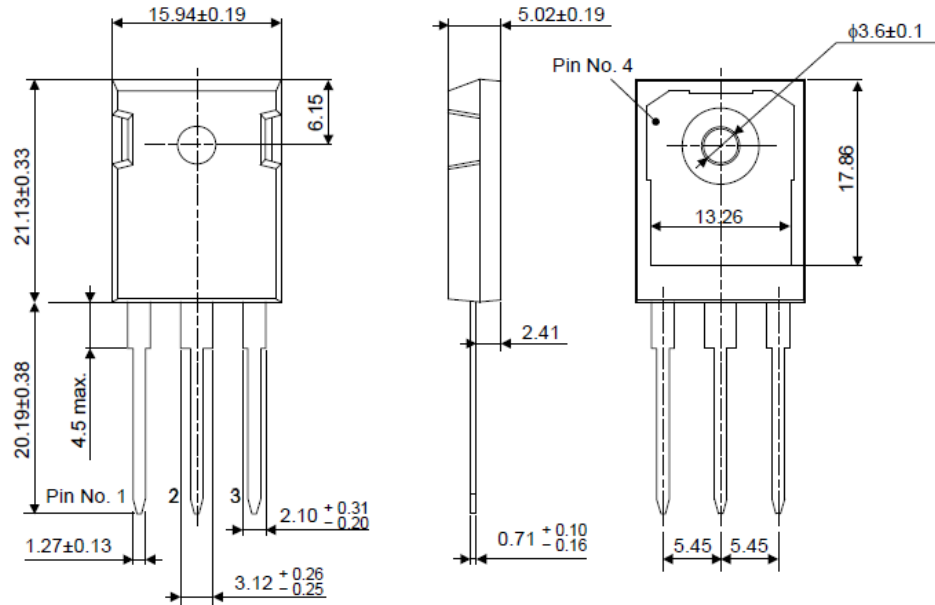

Figure 1. TO-247 Package Dimensions

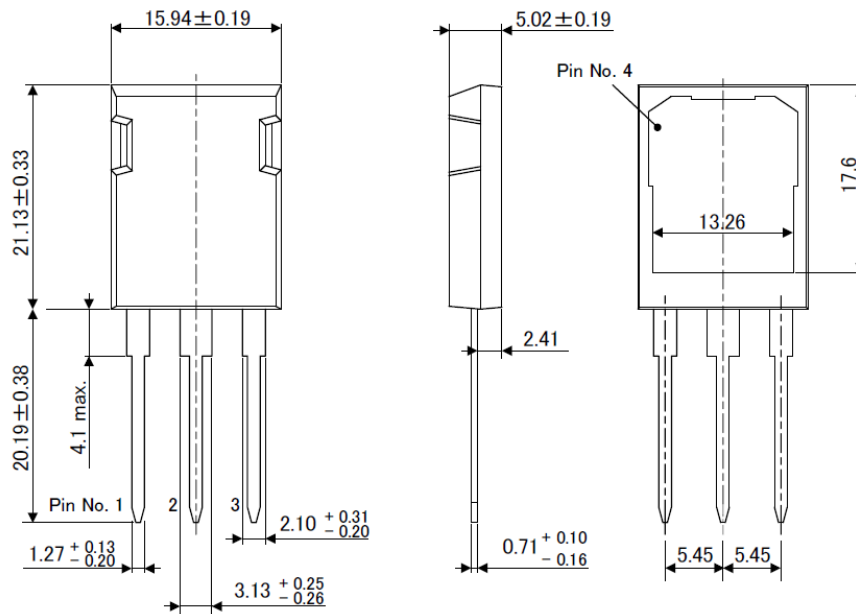

Figure 2. TO-247plus Package Dimensions

### 3. Heat Dissipation Characteristics

Since IGBTs control large amounts of power, the device itself generates heat. Using an IGBT without consideration of this heat generation and without limiting the flowing current will be, in the worst-case scenario, destroy the device. Therefore, it is critical to grasp the heat generation of the device under the corresponding operating conditions and design in heat dissipation appropriate to the heat generated. Note that IGBT heat dissipation performance will also vary depending on mounting conditions such as mounting torque (contact pressure) and thermal grease.

#### 3.1 Mounting Torque (contact pressure)

If attachment to the heatsink is too weak, the contact area will become unstable, leading to poor thermal connectivity. Therefore, adequate mounting torque is required to ensure the device is firmly attached to the heatsink. At the same time, too much mount torque can cause excess contact pressure or stress at the point of attachment, potentially damaging the device. Achieving the right balance is essential.

Make sure to stay within the recommended mounting torque range of 20[N]~100[N]. Note that package strength and reliability can be highly impacted if the mount pressure value exceeds 150[N]. (See Figure 3.)

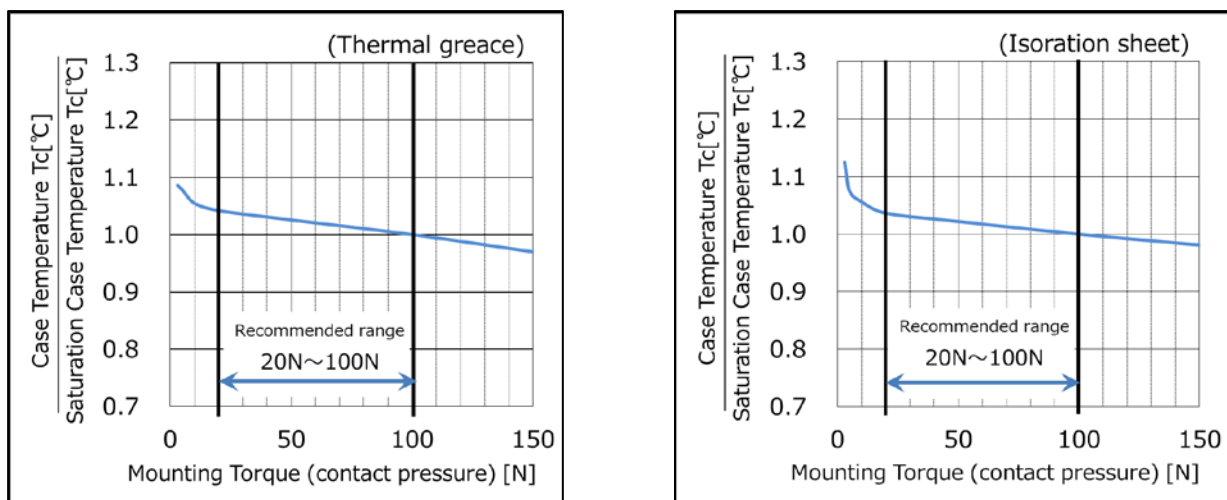

Figure 3. Case Temperature and Mounting Torque Dependency

#### 3.2 Thermal Grease

Both the back tab on the TO-247plus and the heatsink are made of metal and are therefore smooth, but when you enlarged the surface, there are small irregularities of micro-order size creating a layer of air. The high heat insulation characteristics of the air layer deteriorate the device’s heat dissipation. However, our test result has confirmed that the presence/lack of thermal grease shows a change of 1.8 times the value of heat resistance.

In order to obtain the specified dissipation capability, it is necessary to improve the adhesion of the contact surface and heat conduction. We recommend to apply the surface with thermal grease.

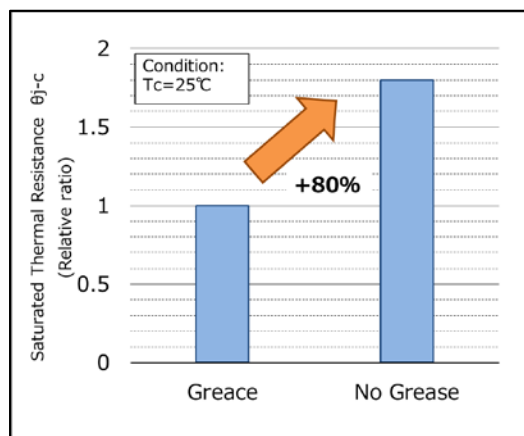

Figure 4. Comparison of Saturated Thermal Resistance With and Without Thermal Grease

### 3.3 Comparison with TO-247

The following is a comparison of heat dissipation of the same chip using TO-247 and TO-247plus packaging.

When comparing thermal resistance  $\theta_{j-c}$  of junction cases, the TO-247plus, with the larger frame for chip mounting, shows improved thermal resistance, which will help suppress heat generation from the device.

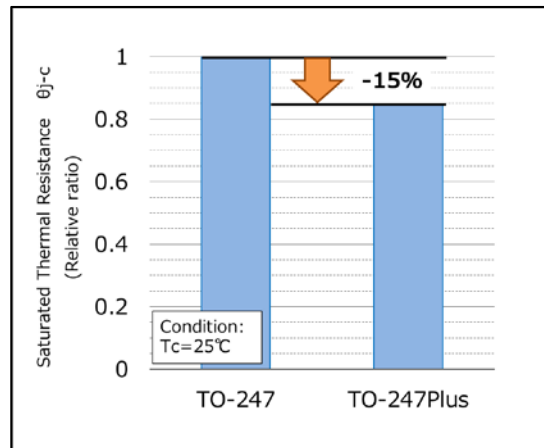

Figure 5. Saturated Thermal Resistance Comparison

## 4. Usage Notes for Mounting and Storage

To use the chip at the specified heat dissipation capability, it is important to mount and store it in a suitable manner. Please keep the following points in mind to ensure the best outcome.

### 4.1 Device Holding Position during Heatsink Mounting

When holding the device, putting all the pressure on one point may result in the mold resin chipping, internal cracking, or other damage to the device. To avoid such damage, instead of keeping the pressure in one spot, press the center of the mold resin by the line or surface.

And then, when holding the multiple devices with a bar, please take care not to put too much pressure to edge of the device (see Figure 6,7).

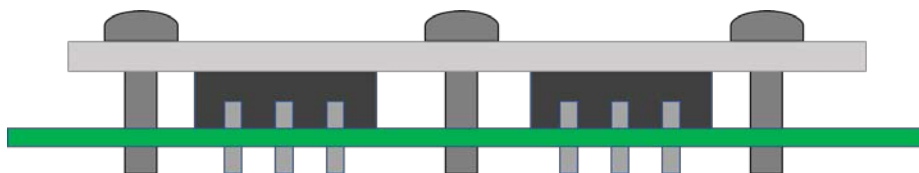

Figure 6. Putting Pressure on the Bar (good example)

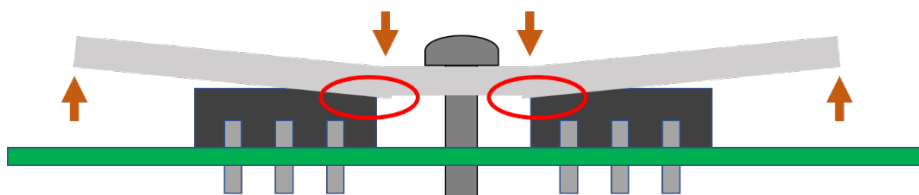

Figure 7. Putting Pressure on the Bar (bad example)

### 4.2 Forming and Cutting Leads

When forming and cutting the leads of semiconductor devices, be careful of the following points:

- When bending the lead, fix between the lead bending point and the package body so that relative stress is not applied between the package body and the lead. Then, do not bend the lead while holding the package body (see figure 8). And, when forming outer leads using a metal mold, use a mechanism that fixes the outer leads. And, the mechanism to secure the lead also please be careful to not put stress on the semiconductor device body (See figure 9).

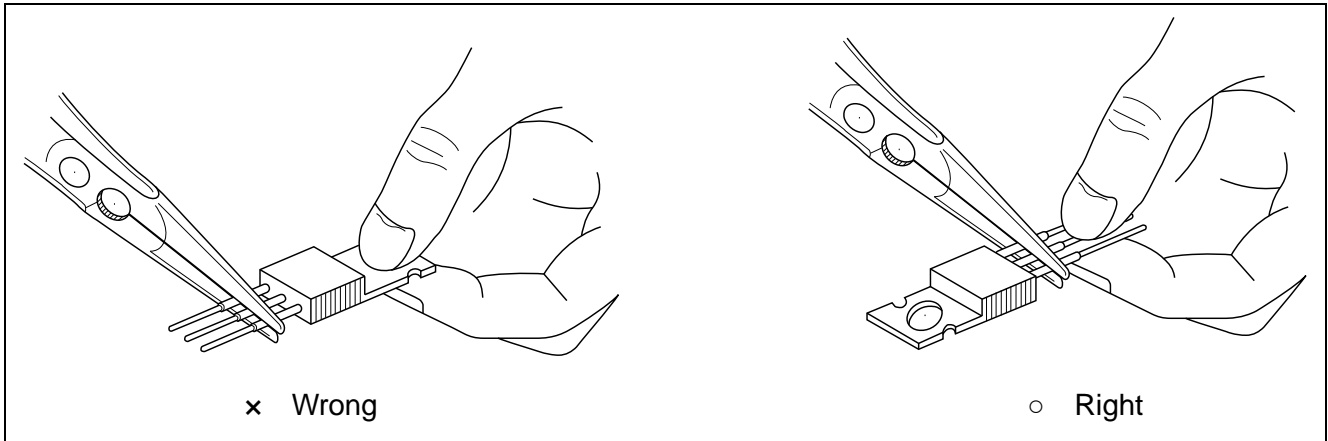

Figure 8. How to Bend Package Leads with Handling

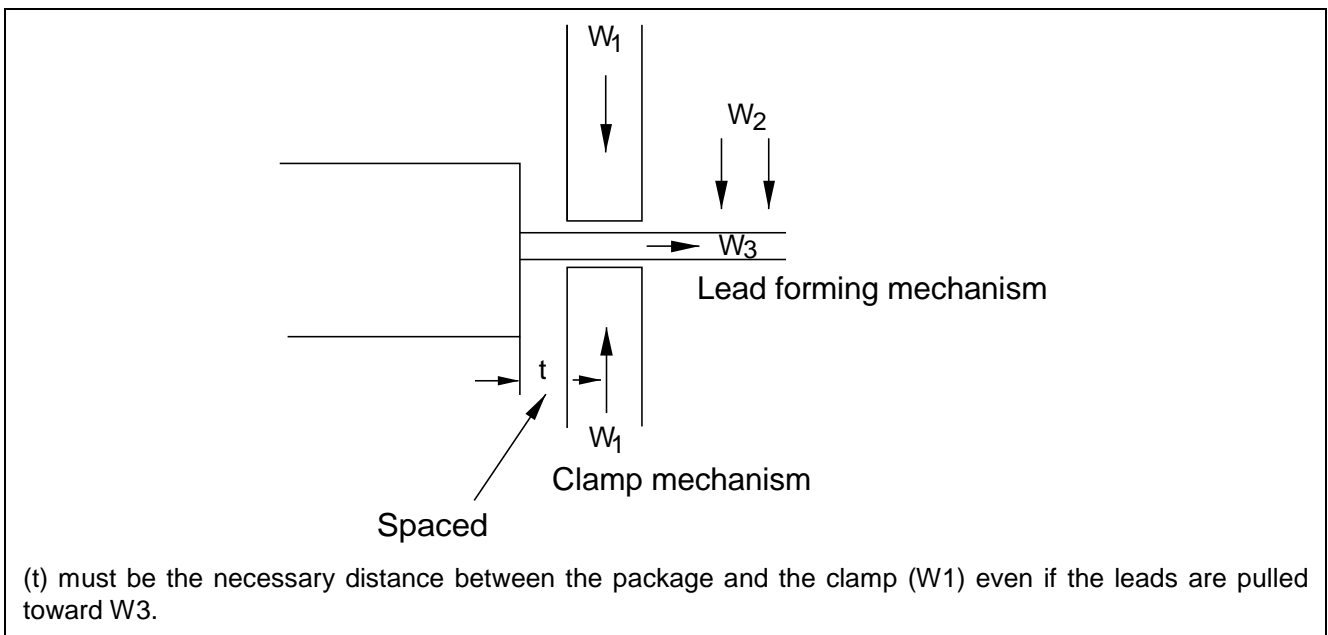

Figure 9. How to Bend the Lead by Using a Mold

- When bending the leads at right angles, make the bend at least 3 mm away from the package end as illustrated in figure 10 (A). Do not bend them more than 90°. When they must be bent less than 90°, allow a space of more than 1.5 mm (See figure 10 (B)).
- Do not repeatedly bend the leads.
- Do not bend them sideways as shown in figure 3 (C).

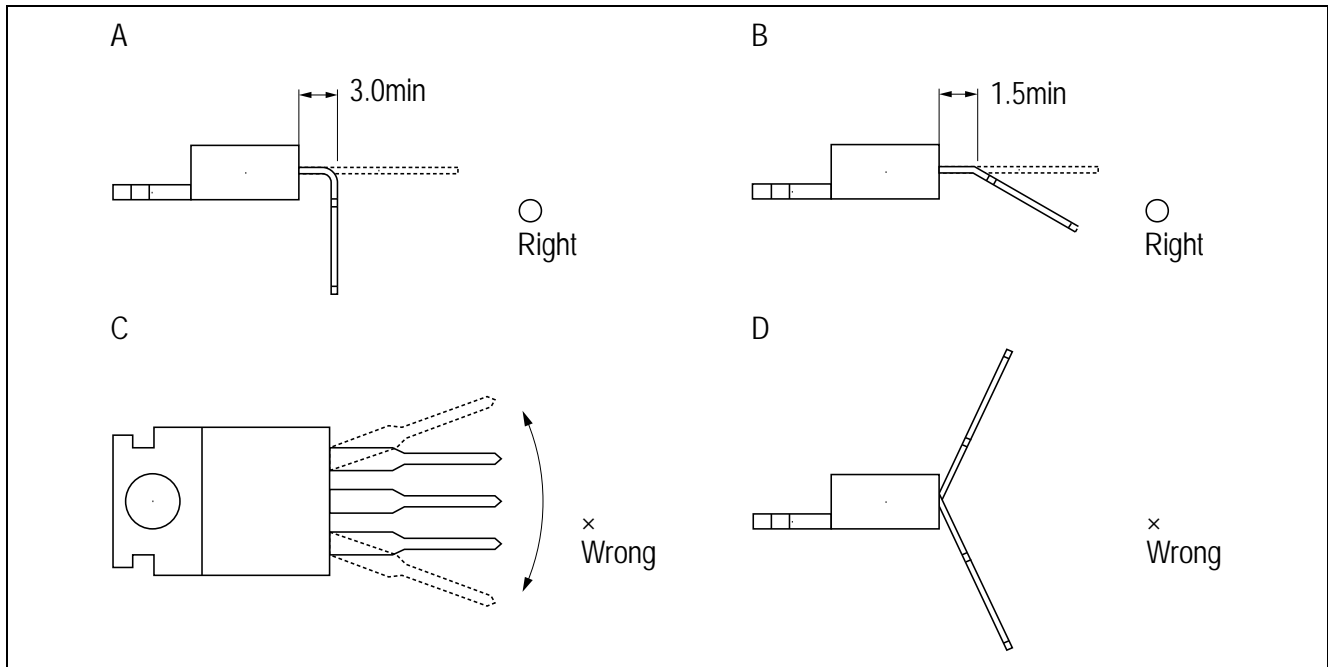

Figure 10. Places and Angles for Lead Bending

- A lead of a semiconductor device can be broken by excessive stress (such as tension) in the axial direction, so do not apply more than the prescribed force. The prescribed stress will vary depending on the cross-sectional area of a lead.
- Depending on the shape of the bending jig or tool, the plated surface of an outer lead can be damaged, so exercise caution.

## 4.3 Storage

When storing semiconductor devices, environmental control is necessary for temperature, humidity, ultraviolet rays, harmful gases such as hydrogen sulfide, radiation such as X-rays, static electricity and strong electromagnetic fields.

### 4.3.1 Storage Environment

#### (1) Ambient temperature and Humidity

The temperature and humidity of the storage location of the semiconductor device are preferably in normal temperature and normal humidity. Avoid temperature and humidity that are too far from these. As a condition of normal temperature and normal humidity, it is desirable that  $T_a = 5$  to  $35$  °C,  $RH = 20$  to  $75$  %RH and  $P = 86$  to  $106$  kPa. When it is very dry, such as during winter, it is necessary to use a humidifier. If tap water is used in the humidifier the chlorine in it can corrode leads of the semiconductor devices, so purified or distilled water should be used.

#### (2) Clean location

Avoid places that are dusty or where corrosive gases are generated.

#### (3) Stable temperature

Avoid environments where there are sudden temperature changes, since moisture condensation can occur in semiconductor devices. Choose darker places with no direct sunlight or strong lighting.

#### (4) Other

Choose a location free from radiation, static electricity, and strong electromagnetic fields.

### 4.3.2 Storage form

- (1) Care is required so that weight is not applied to semiconductor devices in storage. Especially, in the stacked state, excessive weight is applied to the semiconductor device. Avoid placing heavy objects on semiconductor devices. (see figure 14)

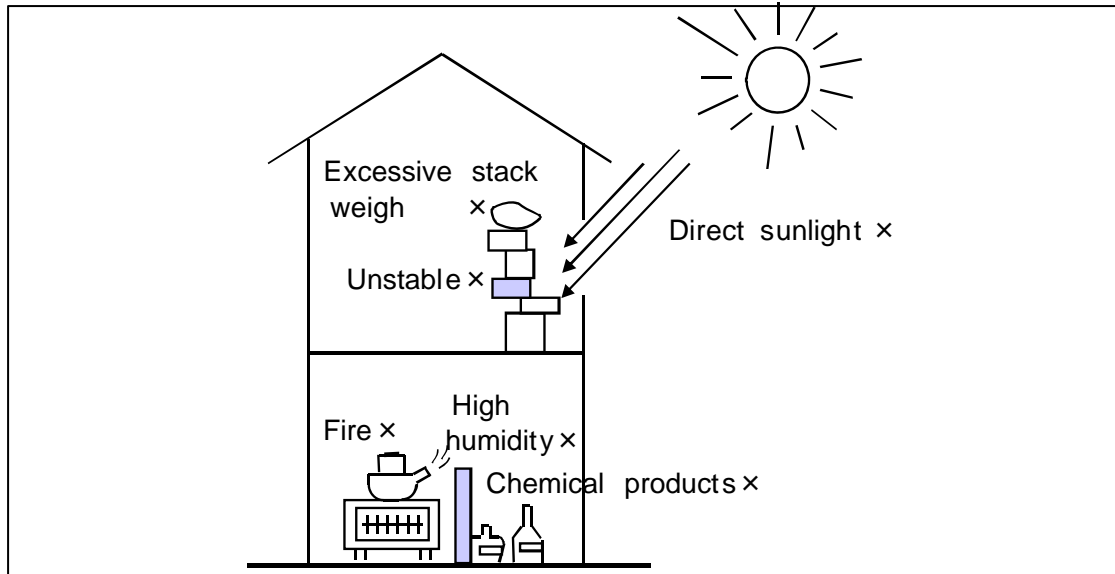

Figure 11. Bad Storage Locations

- (2) Store semiconductor device external terminals in an unprocessed condition. This is to avoid solderability failure during mounting due to occurrence of rust etc.

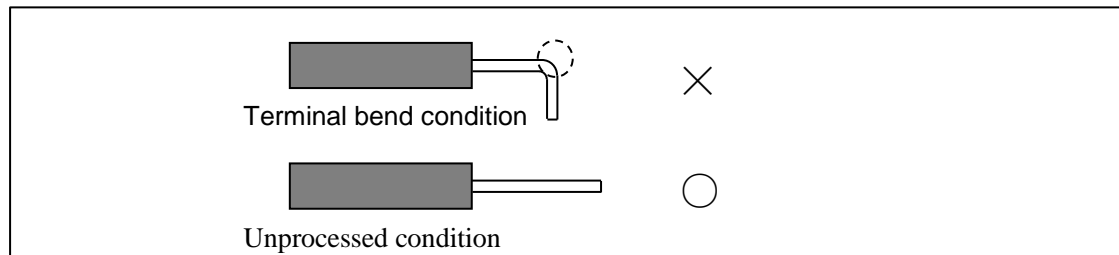

Figure 12. Storing conditions

- (3) Choose containers that do not charge easily for storing semiconductor devices.

### 4.3.3 Long Term Storage

When storing semiconductor devices for long periods (2 years or more), there is a chance of lead pin solderability decrease, rusting, or electrical characteristic faults. The following cautions are especially necessary.

- (1) For the storage environment, please refer to the previous section 4.3.1.
- (2) When long term storage is foreseen, use vacuum packing or put silica gel in a sealed container.
- (3) If long term (2 years or more) has passed under normal storage conditions, it is necessary to inspect solderability and lead rust before use.
- (4) Devices that have been placed in poor environment also must be examined for solderability, and including of rusting of the leads, and electrical characteristics.



## Website and Support

Renesas Electronics Website

<http://www.renesas.com/>

Inquiries

<http://www.renesas.com/contact/>

All trademarks and registered trademarks are the property of their respective owners.

## Notice

1. Descriptions of circuits, software and other related information in this document are provided only to illustrate the operation of semiconductor products and application examples. You are fully responsible for the incorporation or any other use of the circuits, software, and information in the design of your product or system. Renesas Electronics disclaims any and all liability for any losses and damages incurred by you or third parties arising from the use of these circuits, software, or information.
2. Renesas Electronics hereby expressly disclaims any warranties against and liability for infringement or any other claims involving patents, copyrights, or other intellectual property rights of third parties, by or arising from the use of Renesas Electronics products or technical information described in this document, including but not limited to, the product data, drawings, charts, programs, algorithms, and application examples.
3. No license, express, implied or otherwise, is granted hereby under any patents, copyrights or other intellectual property rights of Renesas Electronics or others.
4. You shall not alter, modify, copy, or reverse engineer any Renesas Electronics product, whether in whole or in part. Renesas Electronics disclaims any and all liability for any losses or damages incurred by you or third parties arising from such alteration, modification, copying or reverse engineering.
5. Renesas Electronics products are classified according to the following two quality grades: "Standard" and "High Quality". The intended applications for each Renesas Electronics product depends on the product's quality grade, as indicated below.  
"Standard": Computers; office equipment; communications equipment; test and measurement equipment; audio and visual equipment; home electronic appliances; machine tools; personal electronic equipment; industrial robots; etc.  
"High Quality": Transportation equipment (automobiles, trains, ships, etc.); traffic control (traffic lights); large-scale communication equipment; key financial terminal systems; safety control equipment; etc.  
Unless expressly designated as a high reliability product or a product for harsh environments in a Renesas Electronics data sheet or other Renesas Electronics document, Renesas Electronics products are not intended or authorized for use in products or systems that may pose a direct threat to human life or bodily injury (artificial life support devices or systems; surgical implantations; etc.), or may cause serious property damage (space system; undersea repeaters; nuclear power control systems; aircraft control systems; key plant systems; military equipment; etc.). Renesas Electronics disclaims any and all liability for any damages or losses incurred by you or any third parties arising from the use of any Renesas Electronics product that is inconsistent with any Renesas Electronics data sheet, user's manual or other Renesas Electronics document.
6. When using Renesas Electronics products, refer to the latest product information (data sheets, user's manuals, application notes, "General Notes for Handling and Using Semiconductor Devices" in the reliability handbook, etc.), and ensure that usage conditions are within the ranges specified by Renesas Electronics with respect to maximum ratings, operating power supply voltage range, heat dissipation characteristics, installation, etc. Renesas Electronics disclaims any and all liability for any malfunctions, failure or accident arising out of the use of Renesas Electronics products outside of such specified ranges.
7. Although Renesas Electronics endeavors to improve the quality and reliability of Renesas Electronics products, semiconductor products have specific characteristics, such as the occurrence of failure at a certain rate and malfunctions under certain use conditions. Unless designated as a high reliability product or a product for harsh environments in a Renesas Electronics data sheet or other Renesas Electronics document, Renesas Electronics products are not subject to radiation resistance design. You are responsible for implementing safety measures to guard against the possibility of bodily injury, injury or damage caused by fire, and/or danger to the public in the event of a failure or malfunction of Renesas Electronics products, such as safety design for hardware and software, including but not limited to redundancy, fire control and malfunction prevention, appropriate treatment for aging degradation or any other appropriate measures. Because the evaluation of microcomputer software alone is very difficult and impractical, you are responsible for evaluating the safety of the final products or systems manufactured by you.
8. Please contact a Renesas Electronics sales office for details as to environmental matters such as the environmental compatibility of each Renesas Electronics product. You are responsible for carefully and sufficiently investigating applicable laws and regulations that regulate the inclusion or use of controlled substances, including without limitation, the EU RoHS Directive, and using Renesas Electronics products in compliance with all these applicable laws and regulations. Renesas Electronics disclaims any and all liability for damages or losses occurring as a result of your noncompliance with applicable laws and regulations.
9. Renesas Electronics products and technologies shall not be used for or incorporated into any products or systems whose manufacture, use, or sale is prohibited under any applicable domestic or foreign laws or regulations. You shall comply with any applicable export control laws and regulations promulgated and administered by the governments of any countries asserting jurisdiction over the parties or transactions.
10. It is the responsibility of the buyer or distributor of Renesas Electronics products, or any other party who distributes, disposes of, or otherwise sells or transfers the product to a third party, to notify such third party in advance of the contents and conditions set forth in this document.
11. This document shall not be reprinted, reproduced or duplicated in any form, in whole or in part, without prior written consent of Renesas Electronics.
12. Please contact a Renesas Electronics sales office if you have any questions regarding the information contained in this document or Renesas Electronics products.  
(Note 1) "Renesas Electronics" as used in this document means Renesas Electronics Corporation and also includes its directly or indirectly controlled subsidiaries.  
(Note 2) "Renesas Electronics product(s)" means any product developed or manufactured by or for Renesas Electronics.

(Rev.4.0-1 November 2017)



### SALES OFFICES

Renesas Electronics Corporation

<http://www.renesas.com>

Refer to "<http://www.renesas.com/>" for the latest and detailed information.

#### Renesas Electronics America Inc.

1001 Murphy Ranch Road, Milpitas, CA 95035, U.S.A.  
Tel: +1-408-432-8888, Fax: +1-408-434-5351

#### Renesas Electronics Canada Limited

9251 Yonge Street, Suite 8309 Richmond Hill, Ontario Canada L4C 9T3  
Tel: +1-905-237-2004

#### Renesas Electronics Europe Limited

Dukes Meadow, Millboard Road, Bourne End, Buckinghamshire, SL8 5FH, U.K  
Tel: +44-1628-651-700, Fax: +44-1628-651-804

#### Renesas Electronics Europe GmbH

Arcadiastrasse 10, 40472 Düsseldorf, Germany  
Tel: +49-211-6503-0, Fax: +49-211-6503-1327

#### Renesas Electronics (China) Co., Ltd.

Room 1709 Quantum Plaza, No.27 ZhichunLu, Haidian District, Beijing, 100191 P. R. China  
Tel: +86-10-8235-1155, Fax: +86-10-8235-7679

#### Renesas Electronics (Shanghai) Co., Ltd.

Unit 301, Tower A, Central Towers, 555 Langao Road, Putuo District, Shanghai, 200333 P. R. China  
Tel: +86-21-2226-0888, Fax: +86-21-2226-0999

#### Renesas Electronics Hong Kong Limited

Unit 1601-1611, 16/F., Tower 2, Grand Century Place, 193 Prince Edward Road West, Mongkok, Kowloon, Hong Kong  
Tel: +852-2265-6688, Fax: +852 2886-9022

#### Renesas Electronics Taiwan Co., Ltd.

13F, No. 363, Fu Shing North Road, Taipei 10543, Taiwan  
Tel: +886-2-8175-9600, Fax: +886 2-8175-9670

#### Renesas Electronics Singapore Pte. Ltd.

80 Bendemeer Road, Unit #06-02 Hyflux Innovation Centre, Singapore 339949  
Tel: +65-6213-0200, Fax: +65-6213-0300

#### Renesas Electronics Malaysia Sdn.Bhd.

Unit 1207, Block B, Menara Amcorp, Amcorp Trade Centre, No. 18, Jln Persiaran Barat, 46050 Petaling Jaya, Selangor Darul Ehsan, Malaysia  
Tel: +60-3-7955-9390, Fax: +60-3-7955-9510

#### Renesas Electronics India Pvt. Ltd.

No.777C, 100 Feet Road, HAL 2nd Stage, Indiranagar, Bangalore 560 038, India  
Tel: +91-80-67208700, Fax: +91-80-67208777

#### Renesas Electronics Korea Co., Ltd.

17F, KAMCO Yangjae Tower, 262, Gangnam-daero, Gangnam-gu, Seoul, 06265 Korea  
Tel: +82-2-558-3737, Fax: +82-2-558-5338