Asynchronous State Machine 4x4 Keypad Encoder SLG46537

The application note gives step-by-step guidelines for creating an asynchronous state machine 4x4 keypad encoder using a SLG46537V device. A unique set of components of the SLG46537 allows the creation of such a system.

The application note comes complete with design files which can be found in the Reference section.

Contents

1. Terms and Definitions	2
2. References	2
3. Introduction	3
4. 4-bit Counter on ASM	4
5. I ² C Output	4
6. Conclusion	5
7. Revision History	6

Figures

Figure 1. 4x4 Keypad encoder design	3
Figure 2. ASM block diagram design	4
Figure 3. External Expansion Keyboard (16 Keys 4X4 Matrix)	5

1. Terms and Definitions

ASM	Asynchronous State Machine
ASMM	Asynchronous State Machine Macrocell
MUX	Multiplexer

2. References

For related documents and software, please visit:

[GreenPAK Programmable Mixed-Signal Products | Renesas](#)

Download our free Go Configure Software Hub [1] to open the .gp5 files [2] and view the proposed circuit design. Use the GreenPAK development tools [3] to freeze the design into your own customized IC in a matter of minutes. Renesas provides a complete library of application notes [4] featuring design examples as well as explanations of features and blocks within the Renesas IC.

[1] [Go Configure Software Hub](#), Software Download and User Guide, Renesas Electronics

[2] [AN-1088 Asynchronous State Machine 4x4 Keypad Encoder.gp](#), GreenPAK Design File, Renesas Electronics

[3] [GreenPAK Development Tools](#), GreenPAK Development Tools Webpage, Renesas Electronics

[4] [Application Notes](#), GreenPAK Application Notes, Renesas Electronics

4. 4-bit Counter on ASM

A 4-bit counter is realized using 8-states Asynchronous state machine (ASM). To go through the full cycle and to return into 0th state, 16 state transitions should be done. Two Lower bits are decoded from binary code and control 4 lines, which are connected to the matrix buttons' (switches) columns. If the counter code is equal to «XX00», then the first line will be LOW and three others will be HIGH. Similarly «XX01» code – the second line, «XX10» - the third, «XX11» - the fourth will be LOW and three others - HIGH.

By the external connection each line is connected to the matrix column (1st – to the 1st and so on). The two higher bits control the MUX (sel1 and sel2 inputs), whose inputs are connected to the matrix buttons' (switches) rows. If the counter code is «00XX», then the first row will be connected to the MUX input. Similarly: «01XX» code – the second row, «10XX» - the third row and «11XX» - the fourth row.

When the switched button is detected, the MUX output will go HIGH, which stops the generator and its value will be output to the D0..D3 outputs, or by the request of the MC using I²C protocol.

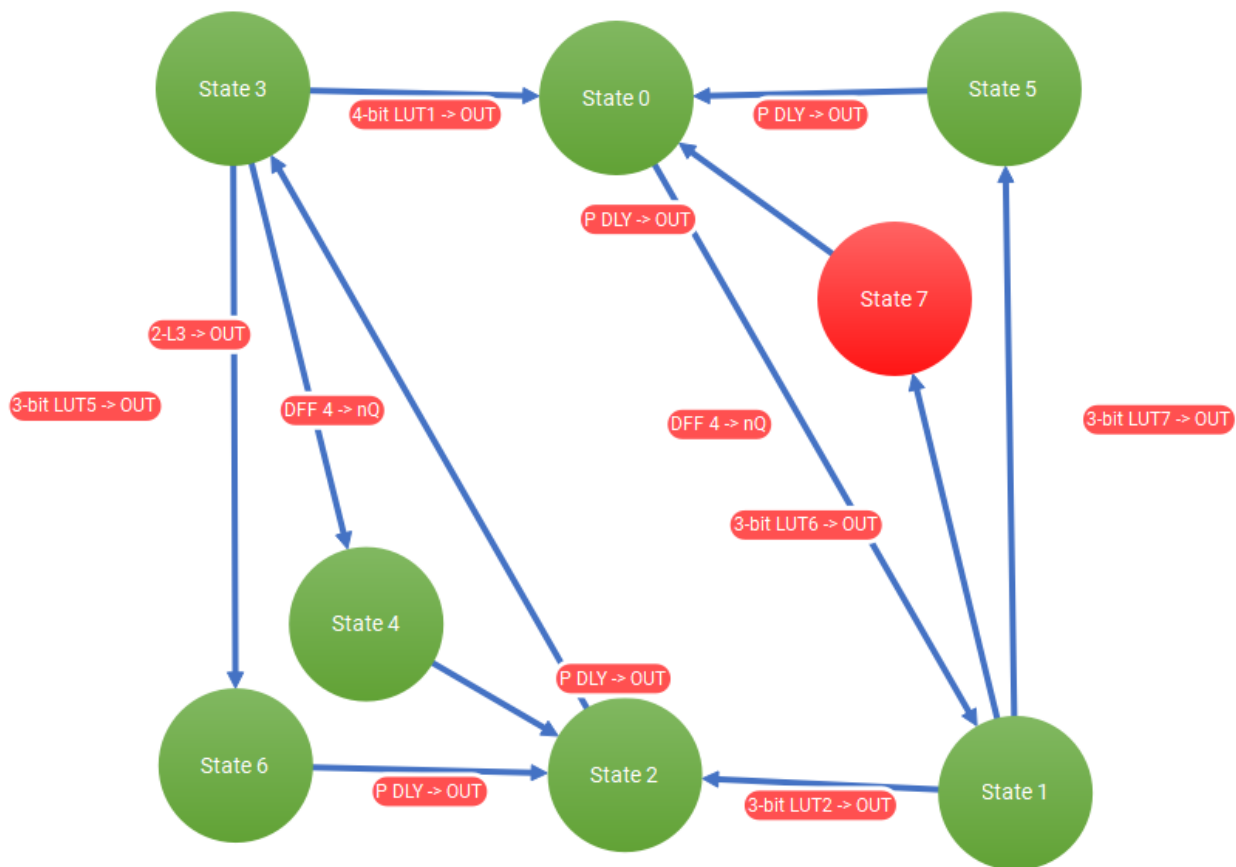

Figure 2. ASM block diagram design

5. I²C Output

In this design the pressed button code transfer function on the two lines using I²C protocol is realized. To do this it is necessary to ask for the next MC address: 3rd MC bank, 247th data byte. The lowest bit of the byte will contain the information whether the button is pressed or not. From the 2nd to 5th bit (4 bits) – pressed button code (if the first bit is equal to “1”). The 6th, 7th and 8th bits information doesn't matter to us and they should be ignored.

The program code (for demo-board "Arduino UNO") example implementation is provided in the attachment. This solution allows using only 2 line interface to a 16-button matrix, which is valuable when limited by a MC with a small number of free pins.

Ext. Keypad 4X4

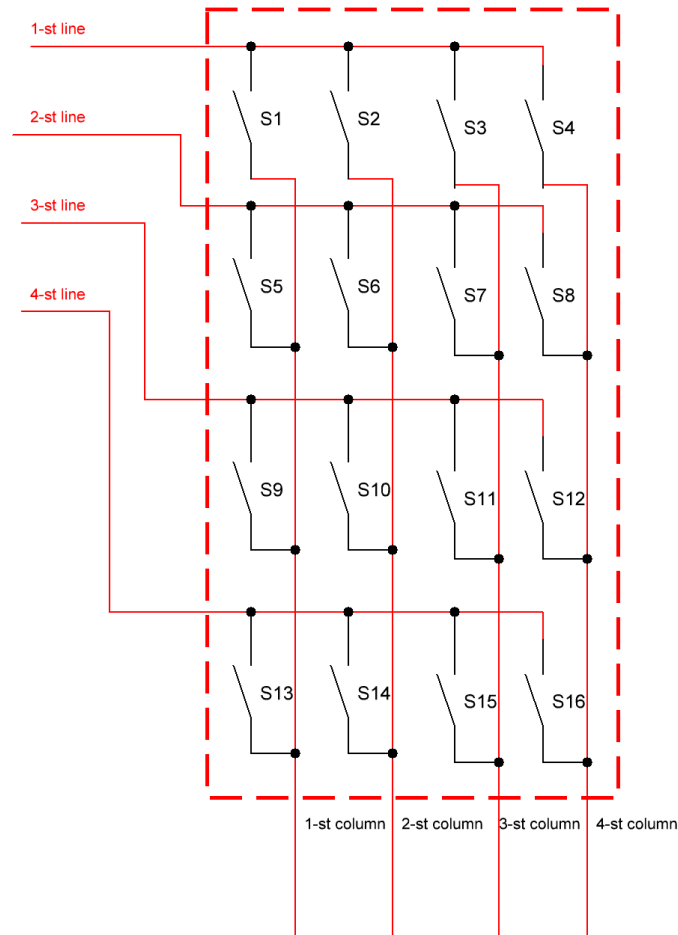

Figure 3. External Expansion Keyboard (16 Keys 4X4 Matrix)

6. Conclusion

This keypad decoder design illustrates the ease of using asynchronous state machine design, and the advantage of freeing up MC pins when used for MC expansion.

7. Revision History

Revision	Date	Description
1.00	Oct 28, 2015	Initial release.
2.00	Apr 7, 2026	The part number has been changed from SLG46531V to SLG46537V.

IMPORTANT NOTICE AND DISCLAIMER

RENESAS ELECTRONICS CORPORATION AND ITS SUBSIDIARIES (“RENESAS”) PROVIDES TECHNICAL SPECIFICATIONS AND RELIABILITY DATA (INCLUDING DATASHEETS), DESIGN RESOURCES (INCLUDING REFERENCE DESIGNS), APPLICATION OR OTHER DESIGN ADVICE, WEB TOOLS, SAFETY INFORMATION, AND OTHER RESOURCES “AS IS” AND WITH ALL FAULTS, AND DISCLAIMS ALL WARRANTIES, EXPRESS OR IMPLIED, INCLUDING, WITHOUT LIMITATION, ANY IMPLIED WARRANTIES OF MERCHANTABILITY, FITNESS FOR A PARTICULAR PURPOSE, OR NON-INFRINGEMENT OF THIRD-PARTY INTELLECTUAL PROPERTY RIGHTS.

These resources are intended for developers who are designing with Renesas products. You are solely responsible for (1) selecting the appropriate products for your application, (2) designing, validating, and testing your application, and (3) ensuring your application meets applicable standards, and any other safety, security, or other requirements. These resources are subject to change without notice. Renesas grants you permission to use these resources only to develop an application that uses Renesas products. Other reproduction or use of these resources is strictly prohibited. No license is granted to any other Renesas intellectual property or to any third-party intellectual property. Renesas disclaims responsibility for, and you will fully indemnify Renesas and its representatives against, any claims, damages, costs, losses, or liabilities arising from your use of these resources. Renesas' products are provided only subject to Renesas' Terms and Conditions of Sale or other applicable terms agreed to in writing. No use of any Renesas resources expands or otherwise alters any applicable warranties or warranty disclaimers for these products.

(Disclaimer Rev.1.01)

Corporate Headquarters

TOYOSU FORESIA, 3-2-24 Toyosu,
Koto-ku, Tokyo 135-0061, Japan
www.renesas.com

Trademarks

Renesas and the Renesas logo are trademarks of Renesas Electronics Corporation. All trademarks and registered trademarks are the property of their respective owners.

Contact Information

For further information on a product, technology, the most up-to-date version of a document, or your nearest sales office, please visit www.renesas.com/contact-us/.