

**Introduction**

The SLG55546 is a combination of current-limited USB port power switch with a USB 2.0 high-speed data line (D+/D-) switch and USB charging port identification circuit. The SLG55546 monitors D+ and D-, providing the correct hand-shaking protocol with compliant client devices.

The following shows how the SLG55546 can be used as a simple current limit circuit without using all the BCID features.

**Conclusion**

Using SLG55546 device is an easy, cost effective, and reliable way to implement current limiting. It features protection circuitry, fault detection, and low power consumption. The design in this application note could easily be used in USB ports/Hubs, Notebooks and Universal Wall Charging Adapters.

**Current limit circuit design**

Figure 1 is an example of using the SLG55546 as a Current Limiter. This circuit limits current to 1.5A, and this level is set by the resistor value on ILIM\_H pin. When the current limit is reached, Fault# pin goes low. Other settings of current limit can be designed with different values of R1.

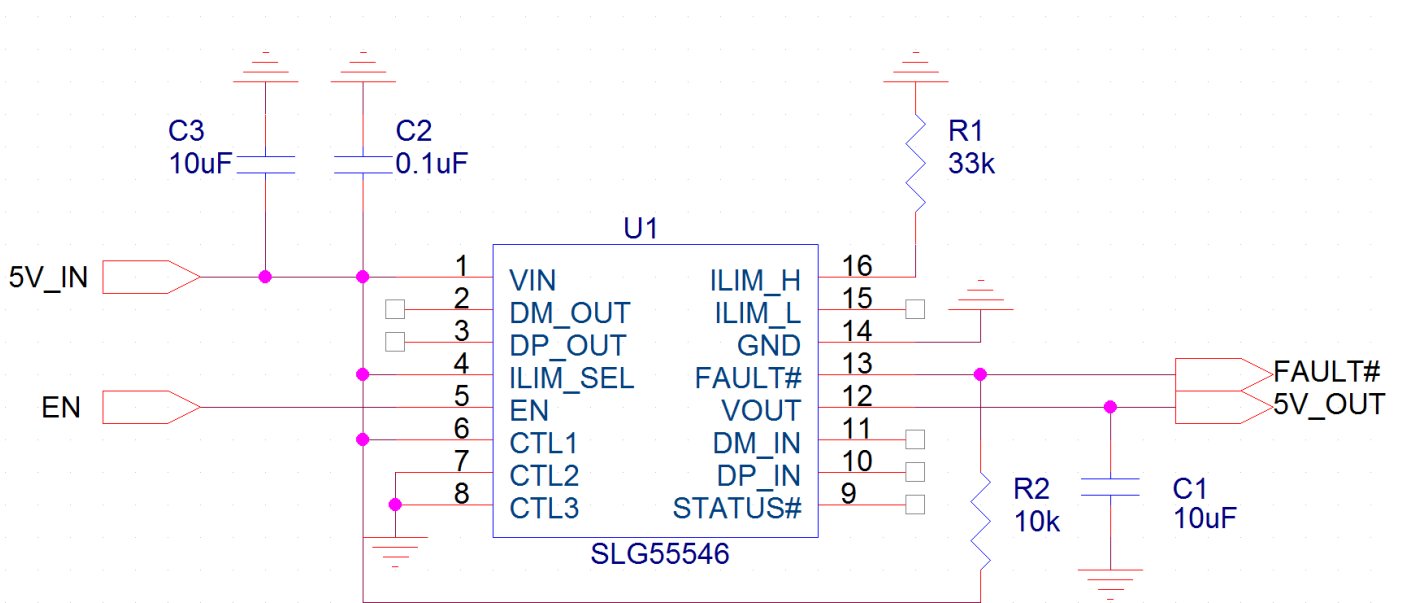

**Figure 1. Implementing the Current Limit Circuit**