

Low Power Constant Brightness LED

SLG46110

Build a compact and efficient constant brightness LED driver using a SLG46110 GreenPAK IC. The design leverages SLG46110's analog comparators and logic blocks to regulate current through LEDs based on voltage feedback from sense resistors. With minimal external components and low power consumption, the solution is ideal for space-constrained and energy-sensitive applications.

Contents

1. Terms and Definitions	1
2. References	1
3. Introduction.....	1
4. LED Constant brightness Circuit Design.....	2
5. LED Constant brightness Circuit Analysis.....	2
6. Conclusion	3
7. Revision History	4

1. Terms and Definitions

IC	Integrated Circuit
LED	Light Emitting Diode

2. References

For related documents and software, please visit:

[GreenPAK Programmable Mixed-Signal Products | Renesas](#)

Download our free Go Configure Software Hub [1] to open the .gp files [2] and view the proposed circuit design. Use the GreenPAK development tools [3] to freeze the design into your own customized IC in a matter of minutes. Renesas provides a complete library of application notes [4] featuring design examples as well as explanations of features and blocks within the Renesas IC.

[1] [GreenPAK Designer Software](#), Software Download and User Guide, Renesas Electronics

[2] [AN-1026 Low power constant brightness LED.gp](#), Renesas Electronics

[3] [GreenPAK Development Tools](#), GreenPAK Development Tools Webpage, Renesas Electronics

[4] [GreenPAK Application Notes](#), GreenPAK Application Notes Webpage, Renesas Electronics

3. Introduction

This design is a Constant Brightness LED Driver. LEDs are current-driven devices whose brightness is proportional to their forward current. Forward current can be controlled in two ways. The first method is using the LED voltage and current curve to determine what voltage needs to be applied to the LED to generate the desired forward current. The second, preferred method of regulating LED current is to drive the LED with a constant-

Low Power Constant Brightness LED

current source. The constant-current source eliminates changes in current due to variations in forward voltage. Preferably, the input power supply regulates the voltage across a current-sense resistor. The power-supply reference voltage and the value of the current-sense resistor determine the LED current.

The LED current is set using the following equation:

$$I_{LED} = \frac{V_{REF}}{R}$$

Where:

- R is connected between the V_{REF} pin and GND.

The maximum I_{LED} is limited by output pin characteristics. The typical current for one output pin is 24 mA at VDD=3.3V, and 68 mA at VDD=5.0 V.

The application circuit can be seen in Figure 2.

4. LED Constant brightness Circuit Design

As shown in Figure 1, a dual constant brightness LED driver can be implemented using two analog comparators (ACMP0 and ACMP1) and two 2-bit LUTs (LUT2 and LUT3).

5. LED Constant brightness Circuit Analysis

When this device is powered on, the output pins (LED1_1, LED1_2, LED2_1 and LED2_2) are LOW. The EN1 (PIN 2) and the EN2 (PIN 4) are independent enables for each pair of output pins.

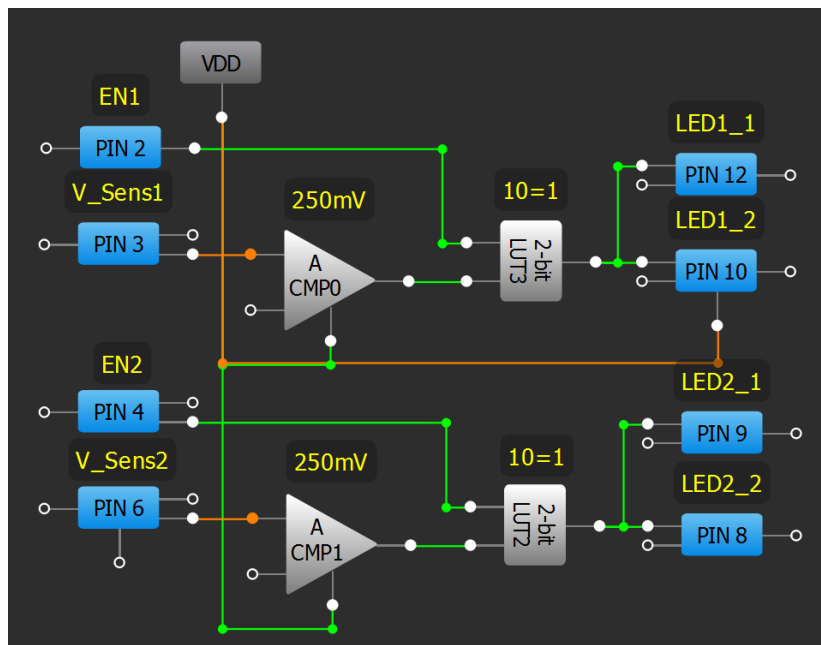

Figure 1: LED Constant brightness Circuit Design

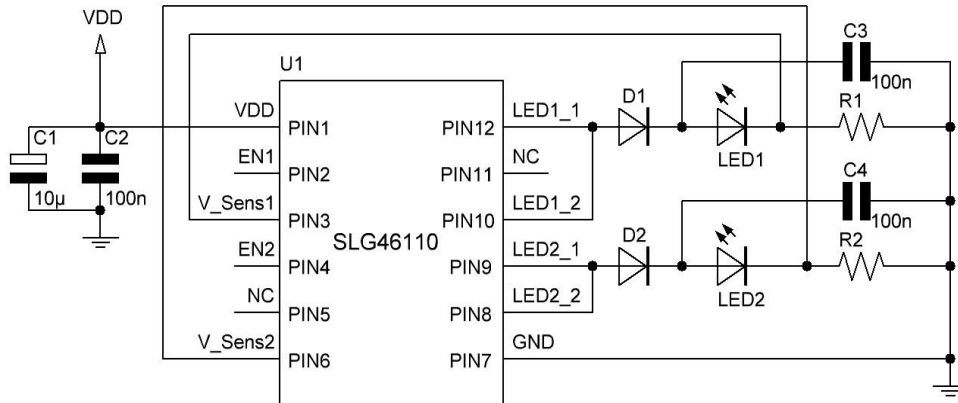

Figure 2: LED Constant brightness Typical Application Circuit

When EN1 is HIGH, the output pins LED1_1 and LED1_2 are enabled. When EN2 is HIGH, the output pins LED2_1 and LED2_2 are enabled. When EN1 is LOW, the output pins LED1_1 and LED1_2 are disabled. When EN2 is LOW, the output pins LED2_1 and LED2_2 are disabled. Capacitors C3, C4 help to smooth the on-off switching behavior of the output pairs as they regulate the average current.

6. Conclusion

A constant brightness LED driver can be easily implemented using a GreenPAK IC. It has low power consumption, small board area footprint, and only a few external components are needed to complete the design.

7. Revision History

Revision	Date	Description
1.00	Jun 26, 2014	Initial release.

IMPORTANT NOTICE AND DISCLAIMER

RENESAS ELECTRONICS CORPORATION AND ITS SUBSIDIARIES (“RENESAS”) PROVIDES TECHNICAL SPECIFICATIONS AND RELIABILITY DATA (INCLUDING DATASHEETS), DESIGN RESOURCES (INCLUDING REFERENCE DESIGNS), APPLICATION OR OTHER DESIGN ADVICE, WEB TOOLS, SAFETY INFORMATION, AND OTHER RESOURCES “AS IS” AND WITH ALL FAULTS, AND DISCLAIMS ALL WARRANTIES, EXPRESS OR IMPLIED, INCLUDING, WITHOUT LIMITATION, ANY IMPLIED WARRANTIES OF MERCHANTABILITY, FITNESS FOR A PARTICULAR PURPOSE, OR NON-INFRINGEMENT OF THIRD-PARTY INTELLECTUAL PROPERTY RIGHTS.

These resources are intended for developers who are designing with Renesas products. You are solely responsible for (1) selecting the appropriate products for your application, (2) designing, validating, and testing your application, and (3) ensuring your application meets applicable standards, and any other safety, security, or other requirements. These resources are subject to change without notice. Renesas grants you permission to use these resources only to develop an application that uses Renesas products. Other reproduction or use of these resources is strictly prohibited. No license is granted to any other Renesas intellectual property or to any third-party intellectual property. Renesas disclaims responsibility for, and you will fully indemnify Renesas and its representatives against, any claims, damages, costs, losses, or liabilities arising from your use of these resources. Renesas' products are provided only subject to Renesas' Terms and Conditions of Sale or other applicable terms agreed to in writing. No use of any Renesas resources expands or otherwise alters any applicable warranties or warranty disclaimers for these products.

(Disclaimer Rev.1.01)

Corporate Headquarters

TOYOSU FORESIA, 3-2-24 Toyosu,
Koto-ku, Tokyo 135-0061, Japan
www.renesas.com

Trademarks

Renesas and the Renesas logo are trademarks of Renesas Electronics Corporation. All trademarks and registered trademarks are the property of their respective owners.

Contact Information

For further information on a product, technology, the most up-to-date version of a document, or your nearest sales office, please visit www.renesas.com/contact-us/.