

Brief Description

The ZSSC4151 is a CMOS integrated circuit for highly accurate amplification and sensor-specific correction of resistive bridge sensor signals. Digital compensation of sensor offset, sensitivity, temperature drift, and non-linearity is accomplished via an internal 16-bit RISC microcontroller running a correction algorithm, with calibration coefficients stored in an integrated EEPROM.

The ZSSC4151 is adjustable to nearly all resistive bridge sensor types. Measured values are provided at the analog voltage output and at the optional digital I²C™* or the ZACwire™ interface, also referred to as the one-wire interface (OWI). The digital interfaces can be used for a simple PC-controlled calibration procedure to program a set of calibration coefficients into an on-chip EEPROM. The ZSSC4151 and the calibration equipment communicate digitally, so the noise sensitivity is greatly reduced. Digital calibration helps keep assembly cost low as no trimming by external devices or lasers is needed.

Features

- Safety and diagnostic functions that can enable support for automotive (ASIL B) and industrial (SIL 2) safety critical applications related to the ISO 26262:2011 and IEC 61508 standards
- Digital compensation of sensor offset, sensitivity, temperature drift, and non-linearity
- Adjustable to nearly all full or half bridge sensors
- Analog gain of 200, supporting sensors with spans down to 1mV/V using the digital zooming option
- Output options: ratiometric 12-bit analog voltage output (e.g., 5-95% or 10-90%) with freely adjustable clamping or ZACwire™ digital one-wire-interface (OWI)
- Temperature compensation: internal or external diode, bridge external series resistance, or RTD
- Sensor biasing by internal voltage
- High voltage and reverse polarity protection up to 40V at all module pins: VDDE, VSSE and AOUT
- Maximum supply current: 7mA
- Short-circuit protection for AOUT
- Traceability via user-defined registers

* I²C™ is a trademark of NXP.

Benefits

- No external trimming components required and only a few external protection devices needed
- PC-controlled configuration and single-pass calibration via ZACwire™ interface: simple, cost-efficient, quick, and precise
- End-of-line calibration via ZACwire™ interface
- I²C™* interface option; can be used in development
- High accuracy: $\pm 0.35\%$ of full-scale output (FSO) at -40°C to 125°C ; $\pm 0.5\%$ FSO at -40°C to 150°C
- Optimized for automotive environments with special protection circuitry and excellent electromagnetic compatibility; AEC-Q100 qualified
- Latch-up immunity: up to $\pm 100\text{mA}$

Available Support

- Evaluation kit
- Application notes
- Calculation tools

Physical Characteristics

- Supply voltage: 4.5 to 5.5V
- Analog-to-digital (ADC) resolution: configurable from 12 to 16 bit
- Large sensor offset correction using digital zooming with 14 to 18 bit resolution
- Output resolution: 12 bit
- Wide operation temperature range: -40°C to 150°C
- RoHS-compliant PQFN24 package or die

Basic Circuit for Dual Bridge Applications

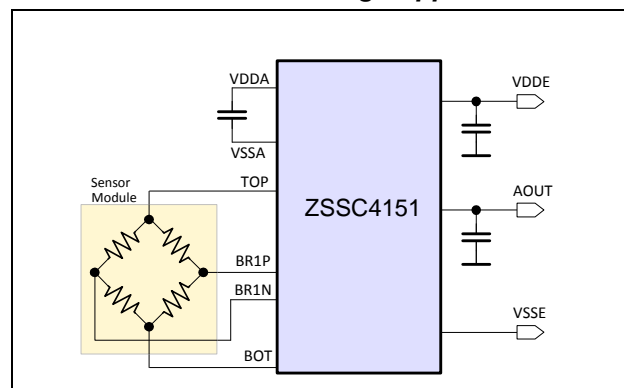

ZSSC4151 Block Diagram

- Typical Applications**
- Pressure sensors
 - Strain gauges
 - PTC RTD temperature sensors

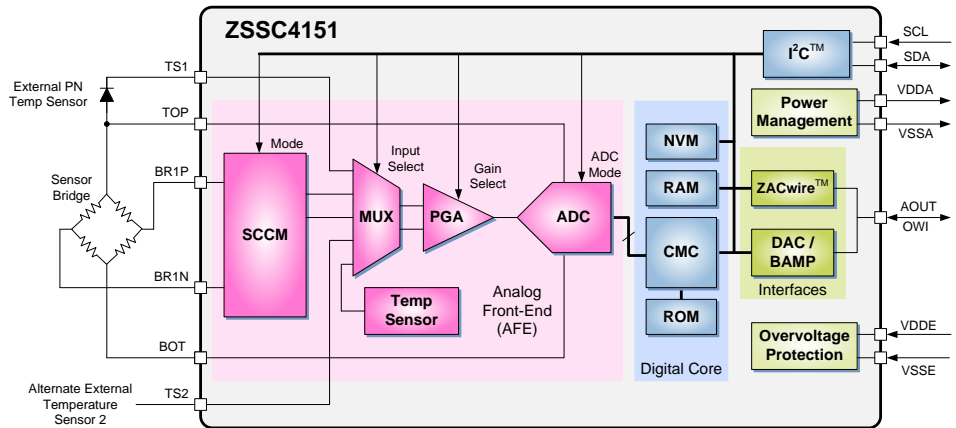

**Analog Application Example:
Pressure and Temperature Sensor**

- 5V module powered by the electronic control unit (ECU) through VCC and GND pins
- Sensor module with 3-pin connector provides ratiometric analog output on AOUT pin
- Media temperature signal derived from external temperature diode
- Temperature compensation via diode on pressure chip
- End-of-line calibration using the one wire interface (OWI) signal on the AOUT pin
- Additional I²C™ interface option

ZSSC4151 Full Bridge, External Diode Temperature Sensor Application

Ordering Information (Contact IDT for die options)

Sales Code	Description	Package
ZSSC4151AE2	ZSSC4151 PQFN24, single bridge input, operating temperature: -40 to 150°C	Add V for tray, R for 13" reel, or W for 7" reel.
ZSSC415xKitV1.10	ZSSC4151 SSC Evaluation Kit: SSC Communication Board, ZSSC415x/6x/7x Evaluation Board, Sensor Replacement Board, 5 samples. Evaluation software is available for download on http://www.idt.com/ZSSC415xKIT . (See kit documentation for details.)	

Document Revision History

Revision	Date	Description
1.00.00	September 14, 2015	First release.
1.00.01	September 23, 2015	Corrections for part order codes and delivery options.
1.01.02	November 11, 2015	Revision of pin names BRP to BR1P and BRN to BR1N corresponding to revisions in data sheet (now revision 1.01).
1.02.02	April 12, 2016	Update for synchronizing revision number with revision 1.02 of the <i>ZSSC4151 Data Sheet</i> , which was updated for adding the minimum ratiometricity error, completion of AEC-Q100 qualification, update for accuracy specification, and extension of the minimum HTOL test time to 3000h. Update to feature sheet accuracy specifications to match update in data sheet. Update to correct kit part code.
	April 20, 2016	Changed to IDT branding.

IMPORTANT NOTICE AND DISCLAIMER

RENESAS ELECTRONICS CORPORATION AND ITS SUBSIDIARIES (“RENESAS”) PROVIDES TECHNICAL SPECIFICATIONS AND RELIABILITY DATA (INCLUDING DATASHEETS), DESIGN RESOURCES (INCLUDING REFERENCE DESIGNS), APPLICATION OR OTHER DESIGN ADVICE, WEB TOOLS, SAFETY INFORMATION, AND OTHER RESOURCES “AS IS” AND WITH ALL FAULTS, AND DISCLAIMS ALL WARRANTIES, EXPRESS OR IMPLIED, INCLUDING, WITHOUT LIMITATION, ANY IMPLIED WARRANTIES OF MERCHANTABILITY, FITNESS FOR A PARTICULAR PURPOSE, OR NON-INFRINGEMENT OF THIRD-PARTY INTELLECTUAL PROPERTY RIGHTS.

These resources are intended for developers who are designing with Renesas products. You are solely responsible for (1) selecting the appropriate products for your application, (2) designing, validating, and testing your application, and (3) ensuring your application meets applicable standards, and any other safety, security, or other requirements. These resources are subject to change without notice. Renesas grants you permission to use these resources only to develop an application that uses Renesas products. Other reproduction or use of these resources is strictly prohibited. No license is granted to any other Renesas intellectual property or to any third-party intellectual property. Renesas disclaims responsibility for, and you will fully indemnify Renesas and its representatives against, any claims, damages, costs, losses, or liabilities arising from your use of these resources. Renesas' products are provided only subject to Renesas' Terms and Conditions of Sale or other applicable terms agreed to in writing. No use of any Renesas resources expands or otherwise alters any applicable warranties or warranty disclaimers for these products.

(Disclaimer Rev.1.01)

Corporate Headquarters

TOYOSU FORESIA, 3-2-24 Toyosu,
Koto-ku, Tokyo 135-0061, Japan
www.renesas.com

Trademarks

Renesas and the Renesas logo are trademarks of Renesas Electronics Corporation. All trademarks and registered trademarks are the property of their respective owners.

Contact Information

For further information on a product, technology, the most up-to-date version of a document, or your nearest sales office, please visit www.renesas.com/contact-us/.