

## Brief Description

The ZSSC3170 is a CMOS integrated circuit for highly accurate amplification and sensor specific correction of bridge sensor signals. Featuring a maximum analog gain of 420, as well as extended offset compensation capabilities, the ZSSC3170 is adjustable to nearly all resistive bridge sensor types.

Digital compensation of offset, sensitivity, temperature drift, and nonlinearity is accomplished via a 16-bit RISC microcontroller. Conditioning coefficients are stored in an EEPROM certified for automotive applications.

Measured values are provided by one of the digital LIN or PWM interfaces. Each interface can support end-of-line calibration using the sensor output. Noise sensitivity is greatly reduced because the calibration equipment and the ZSSC3170 are mated digitally.

For quick and easy evaluation and support for calibrating prototypes, IDT offers the ZSSC3170 SSC Evaluation Kit, which includes evaluation hardware, SSOP20 samples, and software.

## Features

- Complies with LIN specifications 1.3 / 2.0 / 2.1
- Configurable LIN publisher frame content
- Data conversion rate of up to 430Hz fully utilizes the maximum LIN channel capacity of 20kbit/s
- PWM high-side and low-side switches, support for LIN communication for end-of-line calibration
- Digital compensation of offset, gain, temperature effects up to 2<sup>nd</sup> order, and nonlinearity up to 3<sup>rd</sup> order. Compensation of temperature sensor offset, gain, and nonlinearity up to 2<sup>nd</sup> order.
- Internal or external temperature reference
- Media temperature sensing by diode or RTD
- Load dump protection of the LIN pin up to  $\pm 40V$
- Accuracy
  - $\pm 0.25\%$  FSO @ -20 to 85°C
  - $\pm 0.50\%$  FSO @ -40 to 125°C
  - $\pm 1.00\%$  FSO @ -40 to 150°C
- 3 EEPROM words available for optional user data

## Benefits

- Measurement and temperature signal available via one output pin
- Compatible with nearly all resistive bridge inputs
- No external trimming components required
- Single-pass calibration minimizes calibration costs
- End-of-line calibration using sensor output
- Optimized for automotive environments with special protection circuitry, excellent electro-magnetic compatibility, and numerous diagnostic features; AEC-Q100-qualified

## Available Support

- Evaluation Kit
- Application Notes
- Calculation Tools

## Physical Characteristics

- Supply voltage: 7 to 18 V
- Current consumption in Sleep Mode:  $\leq 100\mu A$
- Input span: 1.8 to 267 mV/V
- ADC resolution: 13 to 14 bit
- Output resolution: up to 12-bit (LIN and PWM)
- Operating temperature range: -40 to 125°C
- Extended operating temperature range:  $\leq 150^\circ C$
- RoHS-compliant delivery form options: SSOP20, DFN20, or die

## ZSSC3170 Basic Circuit

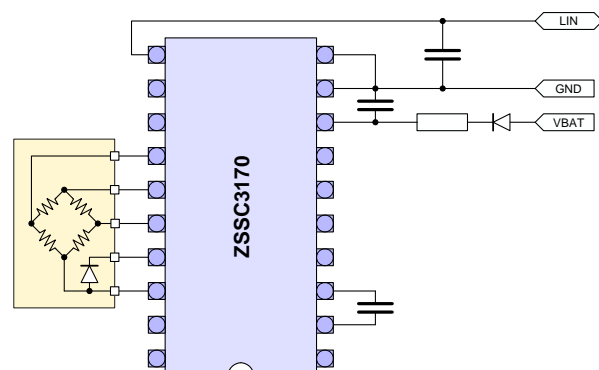

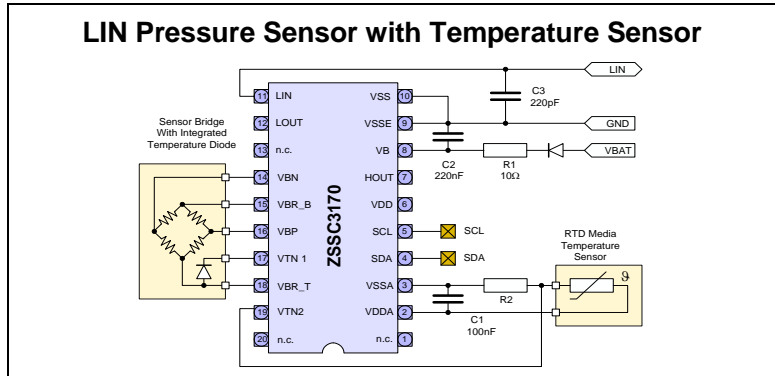
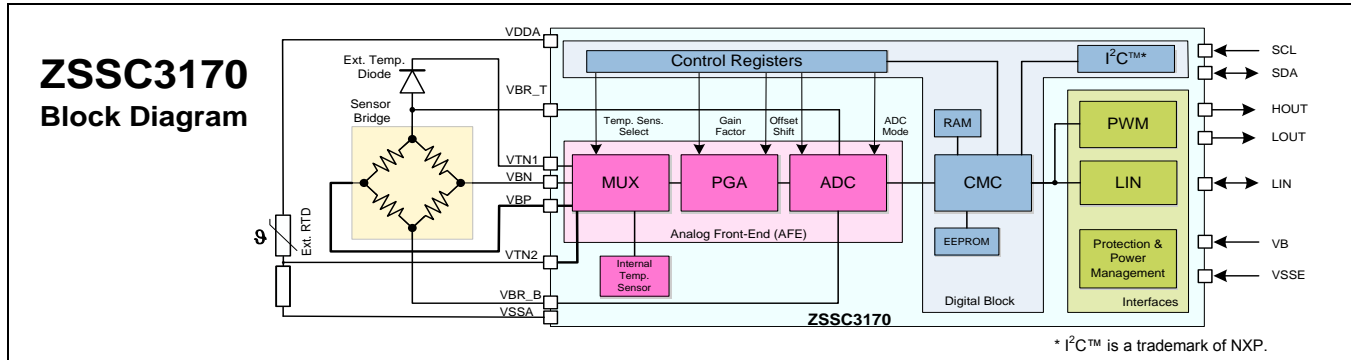

**Ordering Information** (See section 7 in the data sheet for additional options.)

Product Sales Code	Description	Package
ZSSC3170FE1B	ZSSC3170 Die Revision F — Temperature range: -40°C to +150°C	Unsaun on Wafer, 2450 pcs.
ZSSC3170FE1C	ZSSC3170 Die Revision F — Temperature range: -40°C to +150°C	Sawn on Wafer Frame, 2450 pcs.
ZSSC3170FE2	ZSSC3170 SSOP20 Revision F — Temperature range: -40°C to +150°C	Add R for 13" reel, 2000 pcs. Add T for tube, 660 pcs.
ZSSC3170EE1B	ZSSC3170 Die Revision E — Temperature range: -40°C to +150°C	Unsaun on Wafer, 2450 pcs.
ZSSC3170EE1C	ZSSC3170 Die Revision E — Temperature range: -40°C to +150°C	Sawn on Wafer Frame, 2450 pcs.
ZSSC3170EE2	ZSSC3170 SSOP20 Revision E — Temperature range: -40°C to +150°C	Add R for 13" reel, 2000 pcs. Add T for tube, 660 pcs.
ZSSC3170EE3R	ZSSC3170 DFN20 Revision E — Temperature Range -40°C to +150°C	13" Reel, 4500 pcs
ZSSC3170EA1B	ZSSC3170 Die Revision E — Temperature range: -40°C to +125°C	Unsaun on Wafer, 2450 pcs.
ZSSC3170EA1C	ZSSC3170 Die Revision E — Temperature range: -40°C to +125°C	Sawn on Wafer Frame, 2450 pcs.
ZSSC3170EA3R	ZSSC3170 DFN20 Revision E — Temperature Range -40°C to +125°C	13" Reel, 4500 pcs
ZSSC3170KIT	ZSSC3170 Evaluation Kit and 5 SSOP20 samples	Kit

## IMPORTANT NOTICE AND DISCLAIMER

RENESAS ELECTRONICS CORPORATION AND ITS SUBSIDIARIES (“RENESAS”) PROVIDES TECHNICAL SPECIFICATIONS AND RELIABILITY DATA (INCLUDING DATASHEETS), DESIGN RESOURCES (INCLUDING REFERENCE DESIGNS), APPLICATION OR OTHER DESIGN ADVICE, WEB TOOLS, SAFETY INFORMATION, AND OTHER RESOURCES “AS IS” AND WITH ALL FAULTS, AND DISCLAIMS ALL WARRANTIES, EXPRESS OR IMPLIED, INCLUDING, WITHOUT LIMITATION, ANY IMPLIED WARRANTIES OF MERCHANTABILITY, FITNESS FOR A PARTICULAR PURPOSE, OR NON-INFRINGEMENT OF THIRD-PARTY INTELLECTUAL PROPERTY RIGHTS.

These resources are intended for developers who are designing with Renesas products. You are solely responsible for (1) selecting the appropriate products for your application, (2) designing, validating, and testing your application, and (3) ensuring your application meets applicable standards, and any other safety, security, or other requirements. These resources are subject to change without notice. Renesas grants you permission to use these resources only to develop an application that uses Renesas products. Other reproduction or use of these resources is strictly prohibited. No license is granted to any other Renesas intellectual property or to any third-party intellectual property. Renesas disclaims responsibility for, and you will fully indemnify Renesas and its representatives against, any claims, damages, costs, losses, or liabilities arising from your use of these resources. Renesas' products are provided only subject to Renesas' Terms and Conditions of Sale or other applicable terms agreed to in writing. No use of any Renesas resources expands or otherwise alters any applicable warranties or warranty disclaimers for these products.

(Disclaimer Rev.1.01 Jan 2024)

### Corporate Headquarters

TOYOSU FORESIA, 3-2-24 Toyosu,  
Koto-ku, Tokyo 135-0061, Japan  
[www.renesas.com](http://www.renesas.com)

### Trademarks

Renesas and the Renesas logo are trademarks of Renesas Electronics Corporation. All trademarks and registered trademarks are the property of their respective owners.

### Contact Information

For further information on a product, technology, the most up-to-date version of a document, or your nearest sales office, please visit [www.renesas.com/contact-us/](http://www.renesas.com/contact-us/).