

REVISIONS			
DATE CREATED	REV	DESCRIPTION	AUTHOR
4/3/14	00	INITIAL RELEASE	JH
12/11/14	01	ADD PIN1 CHAMFER	JH
4/5/18	02	CHANGE QFN TO VFQFPN, RECALCULATE LAND PATTERN	RC
NOE: REFER TO DCP FOR OFFICIAL RELEASE DATE			

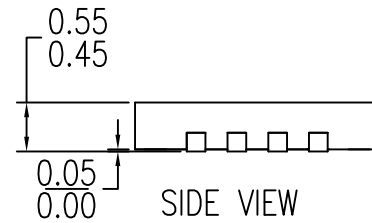
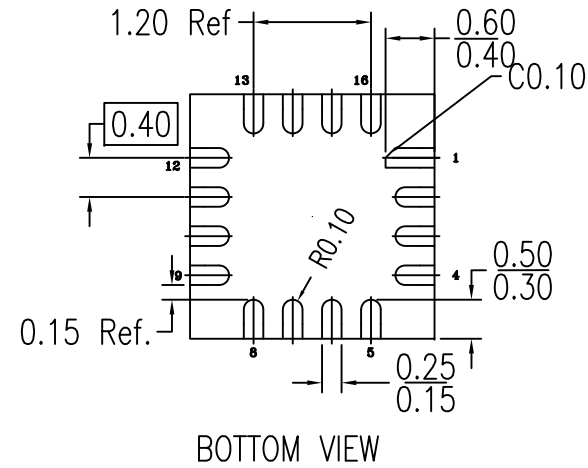
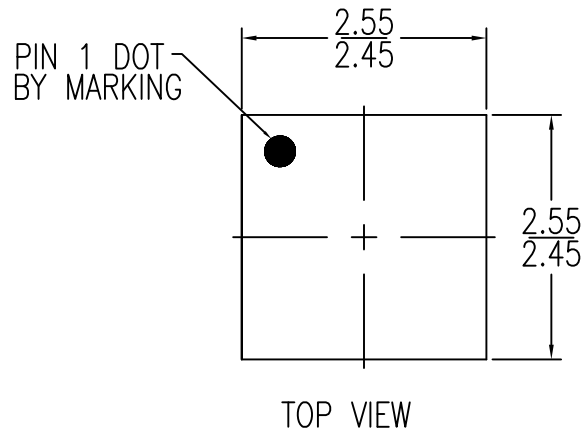

NOTES:

1. ALL DIMENSIONING AND TOLERANCING CONFORM TO ANSI Y14.5M-1982
2. ALL DIMENSIONS ARE IN MILLIMETERS.

TOLERANCES  
UNLESS SPECIFIED  
DECIMAL ANGULAR  
X± ±1°  
XX±  
XXX±



6024 Silver Creek Valley Road  
San Jose CA 95138  
PHONE: (408) 284-8200  
FAX: (408) 284-8591

DRAWN		TITLE CMG16 Package Outline Drawing 2.5 x 2.5 x 0.5 mm Body 0.40mm Pitch VFQFPN	
SIZE	DRAWING No.	REV	
C	PSC-4478	02	
DO NOT SCALE DRAWING			SHEET 1 OF 2

REVISIONS			
DATE CREATED	REV	DESCRIPTION	AUTHOR
4/3/14	00	INITIAL RELEASE	JH
12/11/14	01	ADD PIN1 CHAMFER	JH
4/5/18	02	CHANGE QFN TO VFQFPN, RECALCULATE LAND PATTERN	RC
NOE: REFER TO DCP FOR OFFICIAL RELEASE DATE			

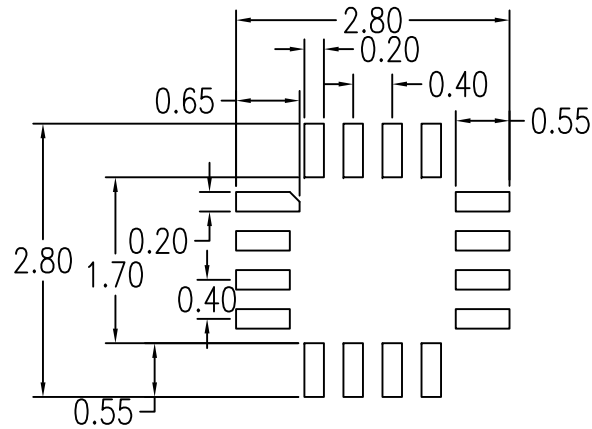

RECOMMENDED LAND PATTERN DIMENSION

NOTES:

1. ALL DIMENSIONS ARE IN MM. ANGLES IN DEGREES.
2. TOP DOWN VIEW AS VIEWED ON PCB.
3. LAND PATTERN RECOMMENDATION PER IPC-7351B GENERIC REQUIREMENT FOR SURFACE MOUNT DESIGN AND LAND PATTERN.

TOLERANCES UNLESS SPECIFIED		 <b>IDT™</b> www.IDT.com	6024 Silver Creek Valley Road San Jose CA 95138 PHONE: (408) 284-8200 FAX: (408) 284-8591	
DECIMAL	ANGULAR			
X±	±1°			
XX±				
XXX±				
DRAWN		TITLE CMG16 Package Outline Drawing 2.5 x 2.5 x 0.5 mm Body 0.40mm Pitch VFQFPN		
SIZE	DRAWING No.	REV		
C	PSC-4478	02		
DO NOT SCALE DRAWING			SHEET 2 OF 2	