

To our customers,

Old Company Name in Catalogs and Other Documents

On April 1st, 2010, NEC Electronics Corporation merged with Renesas Technology Corporation, and Renesas Electronics Corporation took over all the business of both companies. Therefore, although the old company name remains in this document, it is a valid Renesas Electronics document. We appreciate your understanding.

Renesas Electronics website: <http://www.renesas.com>

April 1st, 2010
Renesas Electronics Corporation

Issued by: Renesas Electronics Corporation (<http://www.renesas.com>)

Send any inquiries to <http://www.renesas.com/inquiry>.

Note that the following URLs in this document are not available:

<http://www.necel.com/>

<http://www2.renesas.com/>

Please refer to the following instead:

Development Tools | <http://www.renesas.com/tools>

Download | http://www.renesas.com/tool_download

For any inquiries or feedback, please contact your region.

<http://www.renesas.com/inquiry>

Notice

1. All information included in this document is current as of the date this document is issued. Such information, however, is subject to change without any prior notice. Before purchasing or using any Renesas Electronics products listed herein, please confirm the latest product information with a Renesas Electronics sales office. Also, please pay regular and careful attention to additional and different information to be disclosed by Renesas Electronics such as that disclosed through our website.
2. Renesas Electronics does not assume any liability for infringement of patents, copyrights, or other intellectual property rights of third parties by or arising from the use of Renesas Electronics products or technical information described in this document. No license, express, implied or otherwise, is granted hereby under any patents, copyrights or other intellectual property rights of Renesas Electronics or others.
3. You should not alter, modify, copy, or otherwise misappropriate any Renesas Electronics product, whether in whole or in part.
4. Descriptions of circuits, software and other related information in this document are provided only to illustrate the operation of semiconductor products and application examples. You are fully responsible for the incorporation of these circuits, software, and information in the design of your equipment. Renesas Electronics assumes no responsibility for any losses incurred by you or third parties arising from the use of these circuits, software, or information.
5. When exporting the products or technology described in this document, you should comply with the applicable export control laws and regulations and follow the procedures required by such laws and regulations. You should not use Renesas Electronics products or the technology described in this document for any purpose relating to military applications or use by the military, including but not limited to the development of weapons of mass destruction. Renesas Electronics products and technology may not be used for or incorporated into any products or systems whose manufacture, use, or sale is prohibited under any applicable domestic or foreign laws or regulations.
6. Renesas Electronics has used reasonable care in preparing the information included in this document, but Renesas Electronics does not warrant that such information is error free. Renesas Electronics assumes no liability whatsoever for any damages incurred by you resulting from errors in or omissions from the information included herein.
7. Renesas Electronics products are classified according to the following three quality grades: “Standard”, “High Quality”, and “Specific”. The recommended applications for each Renesas Electronics product depends on the product’s quality grade, as indicated below. You must check the quality grade of each Renesas Electronics product before using it in a particular application. You may not use any Renesas Electronics product for any application categorized as “Specific” without the prior written consent of Renesas Electronics. Further, you may not use any Renesas Electronics product for any application for which it is not intended without the prior written consent of Renesas Electronics. Renesas Electronics shall not be in any way liable for any damages or losses incurred by you or third parties arising from the use of any Renesas Electronics product for an application categorized as “Specific” or for which the product is not intended where you have failed to obtain the prior written consent of Renesas Electronics. The quality grade of each Renesas Electronics product is “Standard” unless otherwise expressly specified in a Renesas Electronics data sheets or data books, etc.
 - “Standard”: Computers; office equipment; communications equipment; test and measurement equipment; audio and visual equipment; home electronic appliances; machine tools; personal electronic equipment; and industrial robots.
 - “High Quality”: Transportation equipment (automobiles, trains, ships, etc.); traffic control systems; anti-disaster systems; anti-crime systems; safety equipment; and medical equipment not specifically designed for life support.
 - “Specific”: Aircraft; aerospace equipment; submersible repeaters; nuclear reactor control systems; medical equipment or systems for life support (e.g. artificial life support devices or systems), surgical implantations, or healthcare intervention (e.g. excision, etc.), and any other applications or purposes that pose a direct threat to human life.
8. You should use the Renesas Electronics products described in this document within the range specified by Renesas Electronics, especially with respect to the maximum rating, operating supply voltage range, movement power voltage range, heat radiation characteristics, installation and other product characteristics. Renesas Electronics shall have no liability for malfunctions or damages arising out of the use of Renesas Electronics products beyond such specified ranges.
9. Although Renesas Electronics endeavors to improve the quality and reliability of its products, semiconductor products have specific characteristics such as the occurrence of failure at a certain rate and malfunctions under certain use conditions. Further, Renesas Electronics products are not subject to radiation resistance design. Please be sure to implement safety measures to guard them against the possibility of physical injury, and injury or damage caused by fire in the event of the failure of a Renesas Electronics product, such as safety design for hardware and software including but not limited to redundancy, fire control and malfunction prevention, appropriate treatment for aging degradation or any other appropriate measures. Because the evaluation of microcomputer software alone is very difficult, please evaluate the safety of the final products or system manufactured by you.
10. Please contact a Renesas Electronics sales office for details as to environmental matters such as the environmental compatibility of each Renesas Electronics product. Please use Renesas Electronics products in compliance with all applicable laws and regulations that regulate the inclusion or use of controlled substances, including without limitation, the EU RoHS Directive. Renesas Electronics assumes no liability for damages or losses occurring as a result of your noncompliance with applicable laws and regulations.
11. This document may not be reproduced or duplicated, in any form, in whole or in part, without prior written consent of Renesas Electronics.
12. Please contact a Renesas Electronics sales office if you have any questions regarding the information contained in this document or Renesas Electronics products, or if you have any other inquiries.

(Note 1) “Renesas Electronics” as used in this document means Renesas Electronics Corporation and also includes its majority-owned subsidiaries.

(Note 2) “Renesas Electronics product(s)” means any product developed or manufactured by or for Renesas Electronics.



User's Manual

MINICUBE[®] OCD Checker

MINICUBE Utility

Target Development Tool

QB-MINI2

QB-78K0MINI

QB-78K0SKX1MINI

Document No. U18591EJ2V0UM00 (2nd edition)

Date Published October 2008 NS

© NEC Electronics Corporation 2007

Printed in Japan

[MEMO]

MINICUBE is a registered trademark of NEC Electronics Corporation in Japan and Germany.

Windows is either a registered trademark or a trademark of Microsoft Corporation in the United States and/or other countries.

The names of other companies and products are the registered trademarks or trademarks of their companies.

- **The information in this document is current as of October, 2008. The information is subject to change without notice. For actual design-in, refer to the latest publications of NEC Electronics data sheets or data books, etc., for the most up-to-date specifications of NEC Electronics products. Not all products and/or types are available in every country. Please check with an NEC Electronics sales representative for availability and additional information.**
- No part of this document may be copied or reproduced in any form or by any means without the prior written consent of NEC Electronics. NEC Electronics assumes no responsibility for any errors that may appear in this document.
- NEC Electronics does not assume any liability for infringement of patents, copyrights or other intellectual property rights of third parties by or arising from the use of NEC Electronics products listed in this document or any other liability arising from the use of such products. No license, express, implied or otherwise, is granted under any patents, copyrights or other intellectual property rights of NEC Electronics or others.
- Descriptions of circuits, software and other related information in this document are provided for illustrative purposes in semiconductor product operation and application examples. The incorporation of these circuits, software and information in the design of a customer's equipment shall be done under the full responsibility of the customer. NEC Electronics assumes no responsibility for any losses incurred by customers or third parties arising from the use of these circuits, software and information.
- While NEC Electronics endeavors to enhance the quality, reliability and safety of NEC Electronics products, customers agree and acknowledge that the possibility of defects thereof cannot be eliminated entirely. To minimize risks of damage to property or injury (including death) to persons arising from defects in NEC Electronics products, customers must incorporate sufficient safety measures in their design, such as redundancy, fire-containment and anti-failure features.
- NEC Electronics products are classified into the following three quality grades: "Standard", "Special" and "Specific".
The "Specific" quality grade applies only to NEC Electronics products developed based on a customer-designated "quality assurance program" for a specific application. The recommended applications of an NEC Electronics product depend on its quality grade, as indicated below. Customers must check the quality grade of each NEC Electronics product before using it in a particular application.
"Standard": Computers, office equipment, communications equipment, test and measurement equipment, audio and visual equipment, home electronic appliances, machine tools, personal electronic equipment and industrial robots.
"Special": Transportation equipment (automobiles, trains, ships, etc.), traffic control systems, anti-disaster systems, anti-crime systems, safety equipment and medical equipment (not specifically designed for life support).
"Specific": Aircraft, aerospace equipment, submersible repeaters, nuclear reactor control systems, life support systems and medical equipment for life support, etc.

The quality grade of NEC Electronics products is "Standard" unless otherwise expressly specified in NEC Electronics data sheets or data books, etc. If customers wish to use NEC Electronics products in applications not intended by NEC Electronics, they must contact an NEC Electronics sales representative in advance to determine NEC Electronics' willingness to support a given application.

(Note)

- (1) "NEC Electronics" as used in this statement means NEC Electronics Corporation and also includes its majority-owned subsidiaries.
- (2) "NEC Electronics products" means any product developed or manufactured by or for NEC Electronics (as defined above).

M8E 02.11-1

INTRODUCTION

- Target Readers** This manual is intended for users who use the MINICUBE OCD Checker when designing and developing a system using an NEC Electronics on-chip flash memory microcontroller.
- Purpose** This manual is intended to give users an understanding of the basic specifications and correct use of the MINICUBE OCD Checker.
- Organization** This manual includes the following sections.
- Overview
 - Installation and startup
 - OCD check for MINICUBE2 and 78K0 microcontroller
 - OCD check for MINICUBE2 and V850 microcontroller
 - OCD check for MINICUBE2 and 78K0S microcontroller
 - OCD check for MINICUBE2 and 78K0R microcontroller
 - OCD check for 78K0 MINICUBE
 - OCD check for 78K0S MINICUBE+
 - OCD checker version indication
 - Uninstallation

How to Read This Manual It is assumed that the readers of this manual have general knowledge of electricity, logic circuits, and microcontrollers. In the explanations of the operation of the applications, it is also assumed that the readers have sufficient knowledge of Windows™. For the usage and terminology of Windows 98, Windows Me, Windows 2000, and Windows XP, refer to each Windows manual.

The mark <R> shows major revised points.

The revised points can be easily searched by copying an "<R>" in the PDF file and specifying it in the "Find what:" field.

To understand the overall operation of the MINICUBE OCD Checker
→ Read this manual according to the **CONTENTS**.

- Conventions**
- | | |
|-------------------------|---|
| Note: | Footnote for item marked with Note in the text |
| Caution: | Information requiring particular attention |
| Remark: | Supplementary information |
| Numeric representation: | Binary ... xxxx or xxxxB |
| | Decimal ... xxxx |
| | Hexadecimal ... xxxxH |
| " ": | Indicates an arbitrary message or item on the screen. |
| []: | indicates the name of a button, command, dialog box, or area. |

Terminology

The meanings of the terms used in this manual are as follows.

Term	Meaning
Emulator	General name that means MINICUBE2, 78K0 MINICUBE and 78K0S MINICUBE+
MINICUBE2	Indicates QB-MINI2, an on-chip debug emulator with programming function.
78K0 MINICUBE	Indicates 78K0 on-chip debug emulator QB-78K0MINI.
78K0S MINICUBE+	Indicates 78K0S/Kx1+ in-circuit emulator QB-78K0SKX1MINI.
Debugger	Indicates NEC Electronics integrated debugger ID78K0-QB, ID78K0S-QB, ID78K0R-QB, or ID850QB.
QBP	Indicates the QB-Programmer, GUI software used for flash programming.
Device file	Binary file that contains device-dependent information. It is prepared for each target device or group of devices in the same lineup.

Related Documents

Please use the following documents in combination with this manual.

The related documents listed below may include preliminary versions. However, preliminary versions are not marked as such.

O Documents Related to Development Tools (User's Manuals)

Document Name	Document Number
MINICUBE OCD Checker	This manual
QB-MINI2 On-Chip Debug Emulator with Programming Function	U18371E
QB-78K0MINI On-Chip Debug Emulator	U17029E
ID78K0-QB Ver. 2.90 Integrated Debugger Operation	U17437E
QB-78K0SKX1MINI In-Circuit Emulator	U17272E
ID78K0S-QB Ver. 2.90 Integrated Debugger Operation	U18247E
ID78K0R-QB Ver. 3.20 Integrated Debugger Operation	U17839E
ID850QB Ver. 3.20 Integrated Debugger Operation	U17435E
QB-Programmer Programming GUI Operation	U18527E
MINICUBE2 Diagnostic Tool	U18588E

Caution The related documents listed above are subject to change without notice.
Be sure to use the latest version of each document for designing, etc.

CONTENTS

CHAPTER 1 OVERVIEW	8
1.1 MINICUBE OCD Checker	8
1.2 Target Emulators and Items to Be Checked	8
1.3 Notes Before Using OCD Checker	9
CHAPTER 2 INSTALLATION AND STARTUP	10
2.1 When NEC Electronics Tool Is Used	10
2.1.1 Installation.....	10
2.1.2 Startup	10
2.2 When Tools Manufactured by Partner Companies (GHS and IAR) are Used	11
2.2.1 Installation.....	11
2.2.2 Startup	11
2.3 Explanation of Each Area	12
CHAPTER 3 OCD CHECK FOR MINICUBE2 AND 78K0 MICROCONTROLLER	14
3.1 Execution of OCD Check	14
3.2 Format of Log File	16
3.3 Error Output	17
3.4 Action for Error	18
CHAPTER 4 OCD CHECK FOR MINICUBE2 AND V850 MICROCONTROLLER	20
4.1 Execution of OCD Check	20
4.2 Format of Log File	22
4.3 Error Output	23
4.4 Action for Error	24
CHAPTER 5 OCD CHECK FOR MINICUBE2 AND 78K0S MICROCONTROLLER	26
5.1 Execution of OCD Check	26
5.2 Format of Log File	28
5.3 Error Output	29
5.4 Action for Error	30
CHAPTER 6 OCD CHECK FOR MINICUBE2 AND 78K0R MICROCONTROLLER	32
6.1 Execution of OCD Check	32
6.2 Format of Log File	34
6.3 Error Output	35
6.4 Action for Error	36
CHAPTER 7 OCD CHECK FOR 78K0 MINICUBE	38
7.1 Execution of OCD Check	38
7.2 Format of Log File	40
7.3 Error Output	41
7.4 Action for Error	43

CHAPTER 8	OCD CHECK FOR 78K0S MINICUBE+	44
8.1	Execution of OCD Check	44
8.2	Format of Log File	46
8.3	Error Output	47
8.4	Action for Error	48
CHAPTER 9	OCD CHECKER VERSION INDICATION	50
CHAPTER 10	UNINSTALLATION	51
APPENDIX A	REVISION HISTORY	52
A.1	Major Revisions in This Edition	52

CHAPTER 1 OVERVIEW

1.1 MINICUBE OCD Checker

MINICUBE OCD Checker (hereinafter referred to as OCD Checker) is a self-check tool for simply detecting problems that may occur when an on-chip debug emulator and target system are connected.

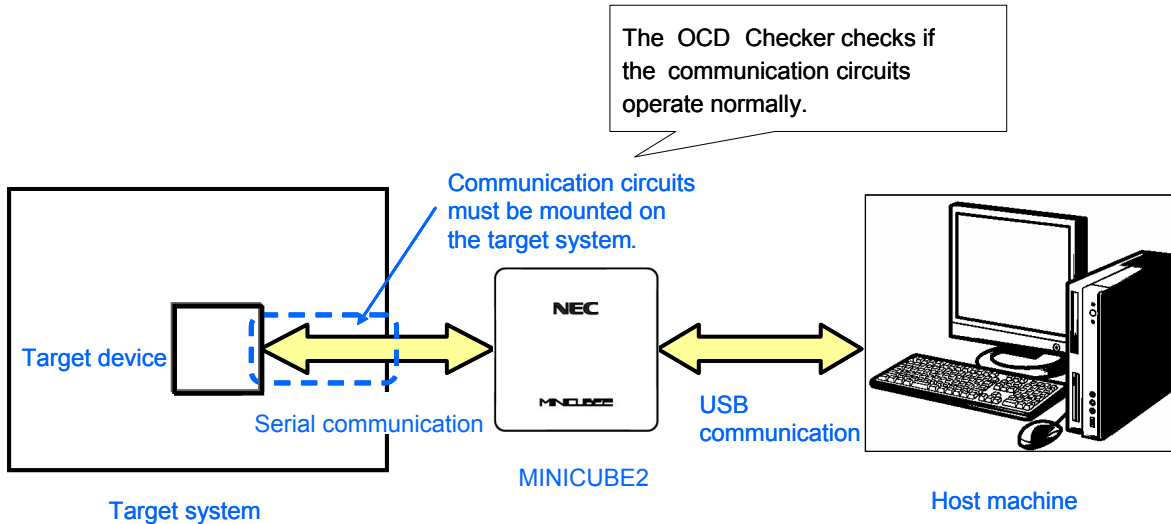

1.2 Target Emulators and Items to Be Checked

The following table lists the items that can be checked with the OCD Checker.

Check Items	MINICUBE2				78K0 MINICUBE	78K0S MINICUBE+
	78K0	V850	78K0S	78K0R		
Status of main clock	√				√	√
Status of target power supply	√	√		√	√	√
Status of $\overline{\text{RESET}}$ pin	√	√	√	√	√	√
Hardware version indication	√	√	√	√	√	√
ID verification	√	√		√	√	
Download of flash memory data	√	√	√	√	√	
Program execution and stop operation	√	√	√	√	√	
Erasement of flash memory data		√	√	√	√	

Remark 1. √ : Available blank : Unavailable

- For the 78K0S MINICUBE+, the system clock status, target power supply status, $\overline{\text{RESET}}$ pin status and hardware version indication are checked, based on connection check of the QB-78K0SMINI and QB-78K0SKX1-DA, both are components of the 78K0S MINICUBE+.

1.3 Notes Before Using OCD Checker

Chapters 1 and 2 present an overview and basic specifications of the OCD Checker, and the following sections provide separate description for the target device and the emulator to be used. To utilize this manual effectively, refer to the following table and see the relevant section for your target device and purpose of use.

Target Device	Emulator	Refer to:
78K0	MINICUBE2	CHAPTER 3 OCD CHECK FOR MINICUBE2 AND 78K0 MICROCONTROLLER
V850		CHAPTER 4 OCD CHECK FOR MINICUBE2 AND V850 MICROCONTROLLER
78K0S		CHAPTER 5 OCD CHECK FOR MINICUBE2 AND 78K0S MICROCONTROLLER
78K0R		CHAPTER 6 OCD CHECK FOR MINICUBE2 AND 78K0R MICROCONTROLLER
78K0	78K0 MINICUBE	CHAPTER 7 OCD CHECK FOR 78K0 MINICUBE
78K0S	78K0S MINICUBE+	CHAPTER 8 OCD CHECK FOR 78K0S MINICUBE+

CHAPTER 2 INSTALLATION AND STARTUP

This section explains how to install and start the OCD Checker.

2.1 When NEC Electronics Tool Is Used

2.1.1 Installation

- <R>
- Select the “Emulator Utilities” check box when installing CubeSuite V1.00 or later. The MINICUBE OCD Checker is then installed automatically.
 - Select the “MINICUBE Utilities Vx.xx” check box when installing ID78K0-QB V2.93 or later. The OCD Checker is then installed automatically.
 - Select the “MINICUBE Utilities Vx.xx” check box when installing ID850QB V3.20 or later. The OCD Checker is then installed automatically.
 - Select the “MINICUBE Utilities Vx.xx” check box when installing QBP V1.00 or later. The OCD Checker is then installed automatically.
 - Select the “MINICUBE Utilities Vx.xx” check box when installing ID78K0S-QB V2.82 or later. The OCD Checker is then installed automatically.
 - Select the “MINICUBE Utilities Vx.xx” check box when installing ID78K0R-QB V3.20 or later. The OCD Checker is then installed automatically.

Caution If multiple debuggers are installed, “MINICUBE Utilities Vx.xx MINICUBE OCD Checker” in the [Latest Version] folder is overwritten. When an ID78K0-QB or ID78K0S-QB earlier than V3.00 is installed, the OCD Checker in the [NEC Tools32] folder is overwritten.

Remark The MINICUBE2 diagnostic tool is installed when the OCD Checker is installed.

<R> 2.1.2 Startup

Start the OCD Checker using either of the following procedure.

- When using CubeSuite
Click the Start menu of Windows, point to “Programs”, “NEC Electronics CubeSuite”, “Emulator Utilities”, “<Target Device>” and then click “OCD Checker”.
- When using the ID850QB, ID78K0-QB, ID78K0S-QB, ID78K0R-QB, or QB-Programmer
Start OCD Checker by using either of the following methods.
 - Click the Start menu of Windows, point to “Programs”, “NEC Electronics Tools”, “Latest Version”, and then click “MINICUBE Utilities Vx.xx OCD Checker”.
 - Click the Start menu of Windows, point to “Programs”, “NEC Tools32”, and then click “OCD Checker”. (For an ID78K0-QB or ID78K0S-QB earlier than V3.00)

Caution If the debugger, QBP, or MINICUBE2 diagnostic tool is running, terminate it before starting the OCD Checker.

Remark When an ID78K0-QB or ID78K0S-QB earlier than V3.00, a link file for startup is created in the [NEC Tools32] and [NEC Electronics Utilities] folders.

2.2 When Tools Manufactured by Partner Companies (GHS and IAR) are Used

2.2.1 Installation

- Download MINICUBE Utilities (*MINICUBE_Utilities_Vxxx.lzh*) from one of the following websites.

<http://www.necel.com/micro/ghs/jpn/exec/execindex.html> (Japanese version)

<http://www.necel.com/micro/ghs/eng/exec/> (English version)

<1> Download *MINICUBE_Utilities_Vxxx.lzh* into an arbitrary folder from the website.

<2> Execute *MINICUBE_Utilities_Vxxx.lzh* in the arbitrary folder.

<3> The following folders and files will be created in the arbitrary folder.

```

MINICUBE_Utilities_Vxxx ┌─ MINICUBE_Utilities_Vxxx
                        │─ MINICUBE_Utilities_Document_Vxxx
                        │─ readme_j.txt
                        └─ readme_e.txt

```

<4> Install *MINICUBE_Utilities_Vxxx* main unit as follows.

- If the OS is Japanese Windows, execute *setup.exe* in the *MINICUBE_Utilities_Vxxx\Japanese\DISK1* folder and install the software according to the installer instructions.
- If the OS is not Japanese Windows, execute *setup.exe* in the *MINICUBE_Utilities_Vxxx\English\DISK1* folder and install the software according to the installer instructions.

Caution Specify *C:\Program Files\NEC Electronics Tools* as an installation destination folder.

Remarks 1. The MINICUBE OCD Checker and MINICUBE2 diagnostic tool can be installed by installing *MINICUBE Utilities Vxxx*.

2. GHS: Green Hills Software, Inc
IAR: IAR Systems AB

2.2.2 Startup

- Click the Start menu of Windows, point to “Programs”, “NEC Electronics Tools”, “Latest Version”, and then click “MINICUBE Utilities Vx.xx OCD Checker”.

Caution If the debugger, QBP, or MINICUBE2 diagnostic tool is running, terminate it before starting the OCD Checker.

2.3 Explanation of Each Area

When the OCD Checker is started, the following window appears.

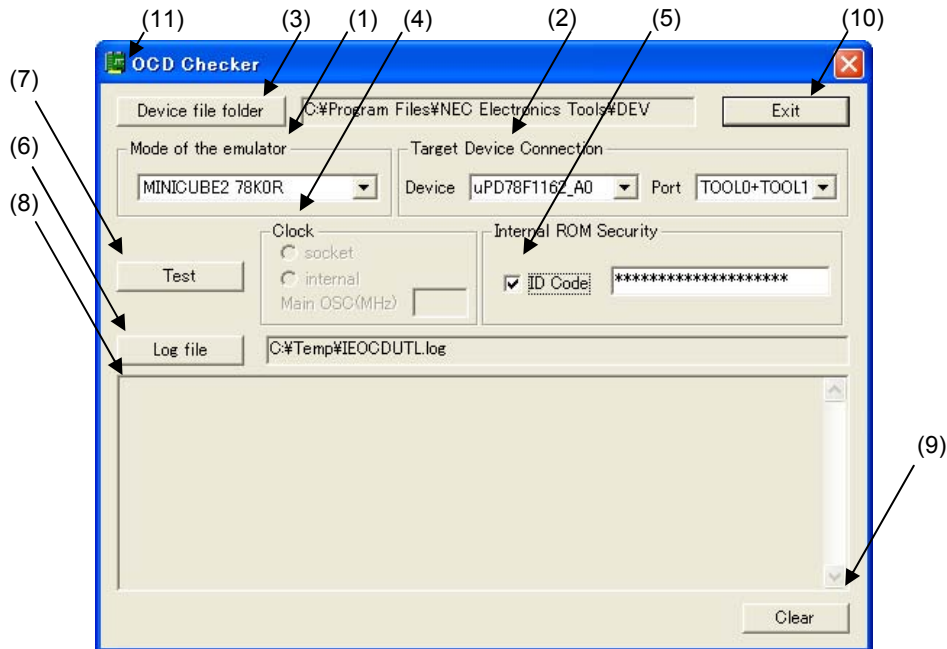

(1) Emulator mode select area

Select from the drop-down list the emulator mode for which target connection check is to be performed.

(2) Target Device Connection area

If "MINICUBE2 V850", "MINICUBE2 78K0S" or "MINICUBE2 78K0R" is selected for the emulator mode, specify from the drop-down list the device file for the target device and the mode for connection with the target system. This menu is unavailable if an item other than "MINICUBE2 V850", "MINICUBE2 78K0S" or "MINICUBE2 78K0R" is selected.

- Device: Select from the drop-down list the target device to be connected.
If the target device (device file) is not displayed in the list, specify the folder where the device file is saved, using the (3) [Device file folder] button in the above window.
- Port: Select the mode for connection with MINICUBE2 and target system from the drop-down list (available only when "MINICUBE2 V850" or "MINICUBE2 78K0R" is selected)

(3) [Device file folder] button

This button is used for searching the folder where the device file is saved to define the device file to be connected when "MINICUBE2 V850", "MINICUBE2 78K0S", or "MINICUBE2 78K0R" is selected. When the device file has been installed using the device file installer (DFINDT), the saved folder is automatically specified.

(4) Clock select area

Select with the radio button the clock supplied to the emulator.

- internal: When a clock mounted in the emulator is used.
- socket: When a clock mounted in the CLK1 socket of the MINICUBE2 78K0-OCD board and a clock mounted in the CLK1 socket of the 78K0 MINICUBE or 78K0S MINICUBE+ are used.
- Main OSC(MHz): Input the target system clock frequency when "MINICUBE2 V850" is selected.

(5) Internal ROM Security setting area

To set the ID code, select the "ID Code" check box; otherwise, the ID code is handled as 0xFF.

If "MINICUBE2 V850" is selected, this area is available only when a debug monitor program has been written to the target device.

This area is unavailable if "MINICUBE2 78K0S" or "78K0S MINICUBE+" is selected for the emulator mode.

(6) [Log file] button

Specifies the file to which the check log will be output (log file).

The location for saving the log file can be changed by clicking the [Log file] button. The log file is created as "IEOCDUTL.log" in a temporary folder by default. Normally, the temporary folder is specified in the tmp or temp environmental variable.

(7) [Test] button

Starts checking. The checked items and their result are output to the log file.

(8) Log view window

Displays the check result. The contents displayed in this area are also output to the log file that is specified using the (6) [Log file] button.

(9) [Clear] button

Clears the log view window. The contents output to the log file are not cleared.

(10) [Exit] button

Terminates the OCD Checker.

(11) System menu

Version can be checked by clicking "About OCD Checker..." on the System menu.

Remark Settings for the OCD Checker are maintained when the OCD Checker is started the next time, except for the setting in the Internal ROM Security setting area.

CHAPTER 3 OCD CHECK FOR MINICUBE2 AND 78K0 MICROCONTROLLER

This section describes the method to check the connection between MINICUBE2 and the target system, which uses a 78K0 microcontroller as the target device, using the OCD Checker.

3.1 Execution of OCD Check

Be sure to terminate the debugger, QBP and MINICUBE2 diagnostic tool before executing the OCD Checker. Perform the connection check according to the following steps (1) to (6).

(1) MINICUBE2 setup

- Power select switch: Set the switch corresponding to the target system.
- Mode select switch: Set to “M2”.
- 78K0-OCD board: Connect the board in accordance with **MINICUBE2 User’s Manual (U18371E)**.
- Target cable: Connect the cable having a pin count corresponding to the target system (16- pin or 10-pin).

(2) Connection and power application

Connect MINICUBE2 to the target system in accordance with **MINICUBE2 User’s Manual (U18371E)**, and the turn on power to the target system.

(3) Setting the OCD Checker

Refer to **2.3 Explanation of Each Area**.

- Emulator mode select area: Select “MINICUBE2 78K0”.
- Clock select area: Select “internal” or “socket”.
- Internal ROM Security setting area: Input the ID code.
- [Log file] button: Specify the log file name and the location for saving the log file.

(4) Click the [Test] button. If an error occurs during checking, refer to **3.3 Error Output** and **3.4 Action for Error**.

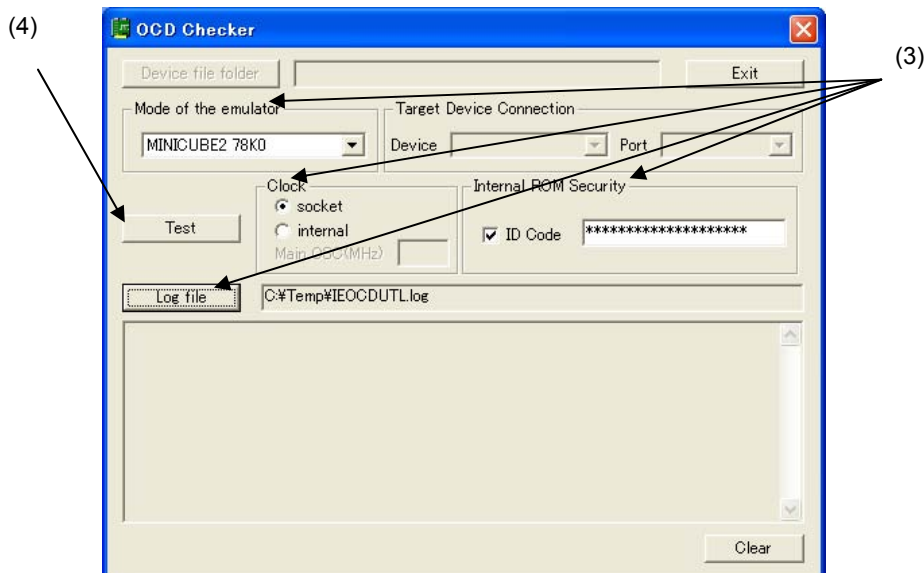

- (5) When all of the tests are complete, the result dialog box is displayed as shown below. The contents displayed in the log view window are saved in the log file. If an NG is displayed, refer to 3.3 Error Output and 3.4 Action for Error. Click the [OK] button.

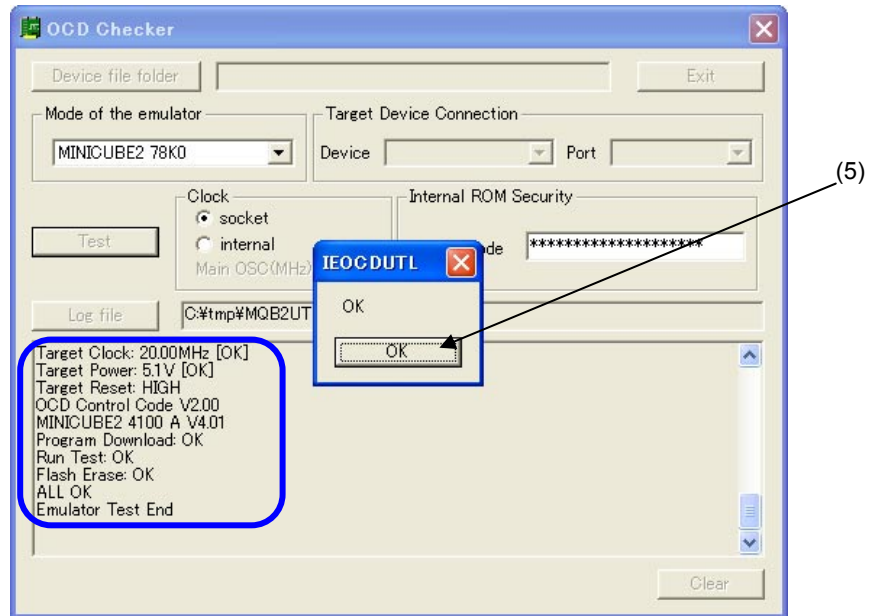

- (6) Click the [Exit] button.

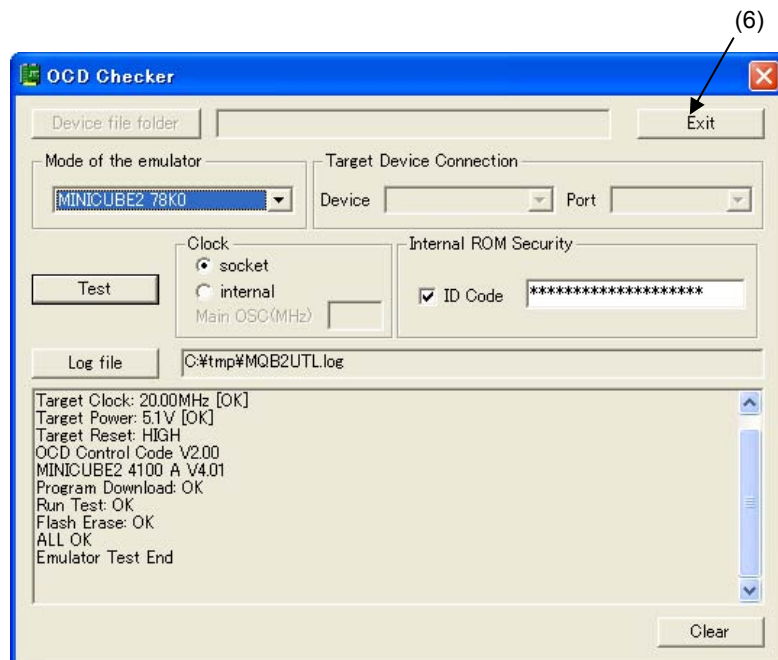

3.2 Format of Log File

The following shows an example of the log file when the check results show "OK" statuses.

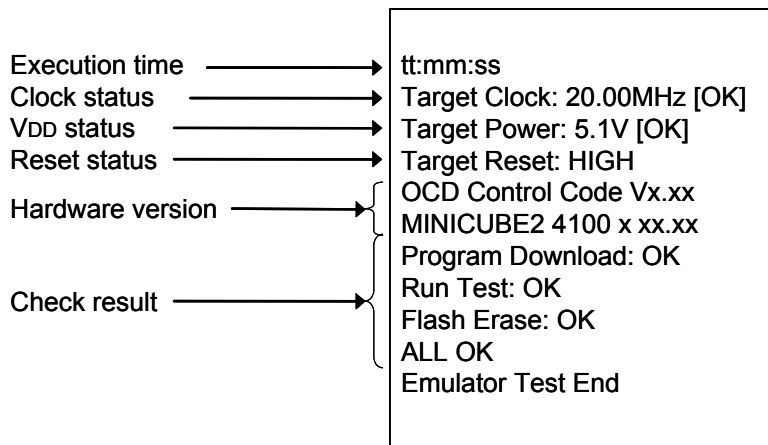

- Execution time: The time when checking was started by clicking the [Test] button
- Clock status: Frequency of the selected clock
- V_{DD} status: V_{DD} value that is applied to the target device
- Reset status: $\overline{\text{RESET}}$ pin status
 - [HIGH] Reset signal input from the target system is HIGH
 - [LOW] Reset signal input from the target system is LOW
- Hardware version: Version of each hardware.
- Check result: [Program Download] ID verification, result of downloading to flash memory in the target device
 - [Run Test] Result of executing and stopping the program
 - [Flash Erase] Erasure result of flash memory in the target device

Remark The version of MINICUBE2 can also be checked with the MINICUBE2 diagnostic tool, debugger and QBP. The latest version of MINICUBE2 firmware can be checked on the following NEC Electronics websites.

Japanese version:

<http://www.necel.com/micro/ods/jpn/index.html>

English version:

<http://www.necel.com/micro/ods/eng/index.html>

See Version-up service → MINICUBE2_Software.

3.3 Error Output

The following describes the operation and display example when an NG is displayed as a result of 3.1 Execution of OCD Check. The message just indicates “NG”, but there are various causes.

- (1) The result is displayed in the dialog box. Click the [OK] button.

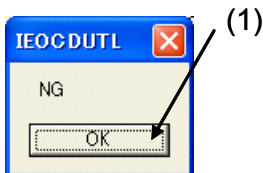

- (2) The contents displayed in the log view window are saved in the log file.

[Log view window]

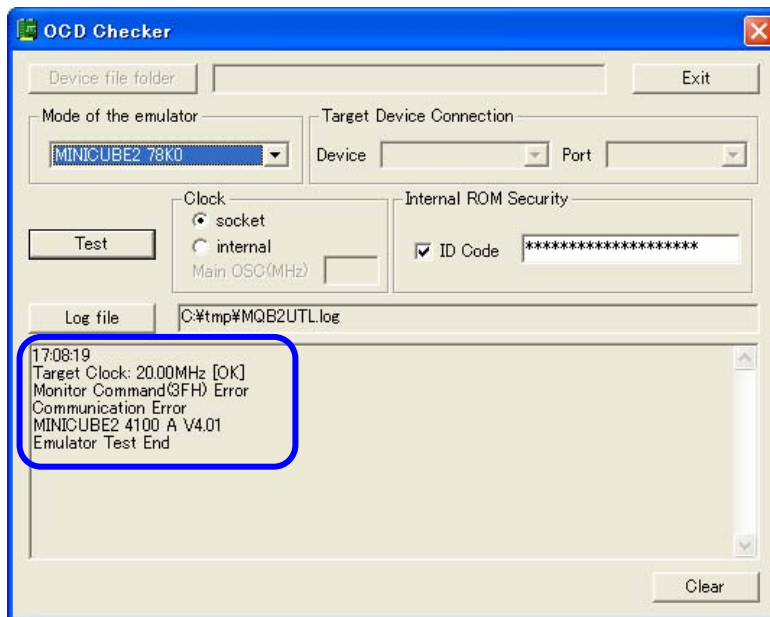

[Log file]

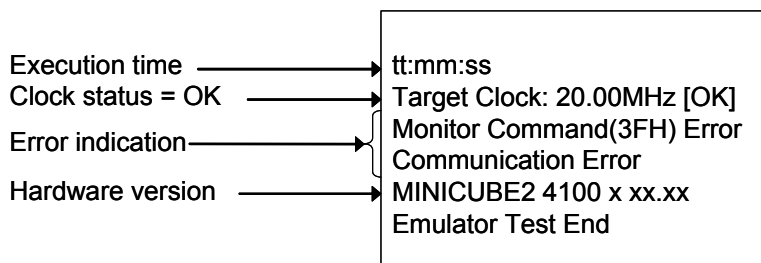

In this NG example, the monitor command (3FH) error and communication error are output. The communication failure between the target device and MINICUBE2 is detected. The cause is an error in the target cable connection between the target system and MINICUBE2.

3.4 Action for Error

The errors that may occur during self-testing (such as setting error) and relevant actions for coping with the errors are listed below.

If an error other than below is displayed, the cause may be a defect in MINICUBE2. If the same error is displayed even after the relevant action is implemented, the cause may be a defect in MINICUBE2. In such a case, consult an NEC Electronics sales representative or distributor.

(1/2)

No.	Error message and action
1	Communication error
	<p>There is no response from the target device.</p> <p>→ Address 0x84 (on-chip debug emulator use enable flag) is set to 0x00 (disable use) or the target system and MINICUBE2 are not connected correctly.</p> <p>Confirm the file of the program written to the target device and connection between the target system and MINICUBE2.</p>
2	Target Power : 0.0V [NG]
	<p>The power supply to the target system cannot be detected.</p> <p>→ Confirm that the power for the target system is on.</p> <p>→ Check the connection between the target system and MINICUBE2</p>
3	78K0 OCD board is not connected
	<p>The 78K0-OCD board is not connected.</p> <p>→ Confirm that the 78K0-OCD board is connected.</p>
4	Target Clock: 0.00MHz [NG]
	<p>The clock mounted in the CLK1 socket may not be operating.</p> <p>→ Confirm the clock oscillation, or remove the clock mounted in the CLK1 socket in the 78K0-OCD board and use the internal clock.</p>
5	Select Socket Clock
	<p>The clock mounted in the CLK1 socket is not selected.</p> <p>→ Select "socket" for the clock setting, or remove the clock mounted in the CLK1 socket and select "internal".</p>
6	Driver open error
	<p>(1) There is no response from MINICUBE2.</p> <p>→ Check the connections between the host machine and the USB cable, and the USB cable and the MINICUBE2.</p> <p>→ Turn all the power supplies off according to the procedures described in the user's manual. (MINICUBE2 is turned off by disconnecting the USB cable.)</p> <p>Turn all the power supplies on, and then click the [Test] button.</p> <p>If an error message is displayed even after taking these measures, restart Windows on the host machine before turning all the power supplies on.</p> <p>(2) The debugger has been started.</p> <p>→ The debugger and the OCD Checker cannot be started simultaneously, so terminate the debugger.</p> <p>(3) The USB driver may not be operating normally.</p> <p>→ Confirm the cable connection and the USB driver setup. Re-install the USB driver as necessary.</p> <p>(4) The debugger may not be installed normally.</p> <p>→ Re-install the debugger.</p>

No.	Error message and action
7	Incorrect ID code
	The input ID code is incorrect. → Confirm the ID code written to the target device and re-input the ID code.
8	Log file write error
	The specified log file cannot be accessed. → Confirm that the folder, path, and file are write-enabled.
9	Test Rom Command(xxH) Error, Monitor Command(xxH) Error
	Communication between the target device and MINICUBE2 has failed. → The cause may be a problem in the electrical specifications of the cable or the target system, or the USB driver may not be operating normally. Confirm the connection and restart Windows on the host machine.
10	Write Memory, Read Memory, Data verify error
	The internal RAM cannot be accessed. The target device may be damaged. → Exchange the target device.
11	_Flash Env Error, _Flash Get Info Error, _Flash Block Blank Check Error, _Flash Block Erase Error, _Flash Word Write Error, _Flash Block Verify Error, _Flash Word Read Error, Data Verify Error
	An error occurred while writing to the flash memory. → The cause may be the security flag setting, so clear the security flag setting via the QBP. The target device may be damaged, so exchange the target device.
12	Break Timeout, ERROR: SP Break Test, ERROR: Execute Break Test1, ERROR: SFR Access Break Test, ERROR: Read Access Break Test1, ERROR: Read Access Break Test2, ERROR: Write Access Break Test1, ERROR: Write Access Break Test2, ERROR: Step Break Test, ERROR: Execute Break Test2
	The target device may be damaged, so exchange the target device.

CHAPTER 4 OCD CHECK FOR MINICUBE2 AND V850 MICROCONTROLLER

This section describes the method to check the connection between MINICUBE2 and the target system, which uses a V850 microcontroller as the target device, using the OCD Checker.

4.1 Execution of OCD Check

Be sure to terminate the debugger, QBP and MINICUBE2 diagnostic tool before executing the OCD Checker.

The 78K0-OCD board and 10-pin target cable (accessories of MINICUBE2) are not used.

Perform the connection check according to the following steps (1) to (6).

(1) MINICUBE2 setup

- Power select switch: Set the switch corresponding to the target system.
- Mode select switch: Set to "M2".
- Target cable: Connect the 16- pin target cable.

(2) Connection and power application

Connect MINICUBE2 to the target system in accordance with **MINICUBE2 User's Manual (U18371E)**, and the turn on power to the target system.

(3) Setting the OCD Checker

Refer to **2.3 Explanation of Each Area**.

- Emulator mode select area: Select "MINICUBE2 V850".
- Target Device Connection area: [Device] Select the target device to be connected from the drop-down list.
If the target device name is not displayed, specify the device file saving destination folder using the [Device file folder] button.
[Port] Select the mode for connection with target system from the drop-down list.
- Clock select area: Input the original main clock frequency in the "Main OSC(MHz)" text box.
- Internal ROM Security setting area: Input the ID code.
- [Log file] button: Specify the log file name and the location for saving the log file.

- (4) Click the **[Test]** button. If an error occurs during checking, refer to 4.3 **Error Output** and 4.4 **Action for Error**.

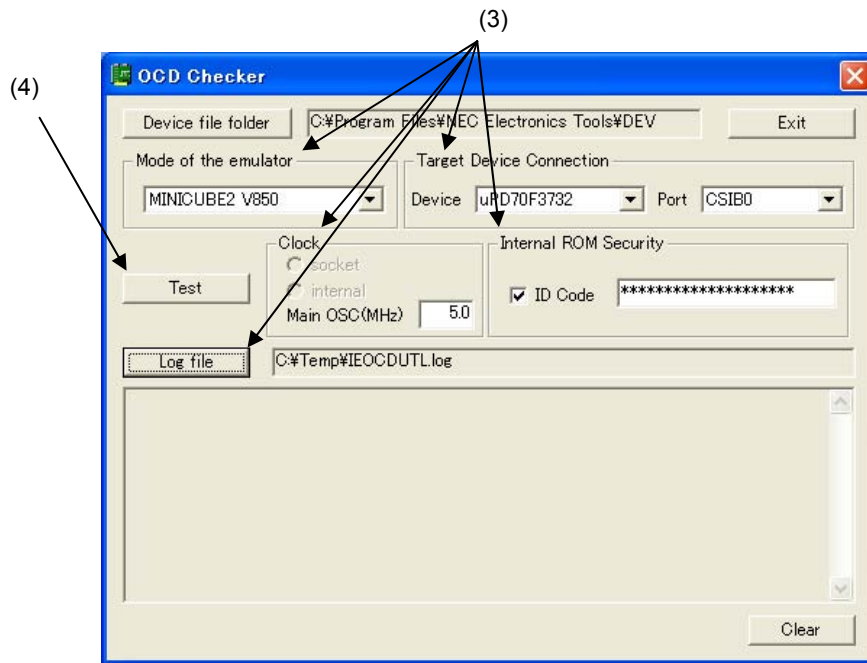

- (5) When all of the tests are complete, the result dialog box is displayed as shown below. The contents displayed in the log view window are saved in the log file. If an NG is displayed, refer to 4.3 **Error Output** and 4.4 **Action for Error**.

Click the **[OK]** button.

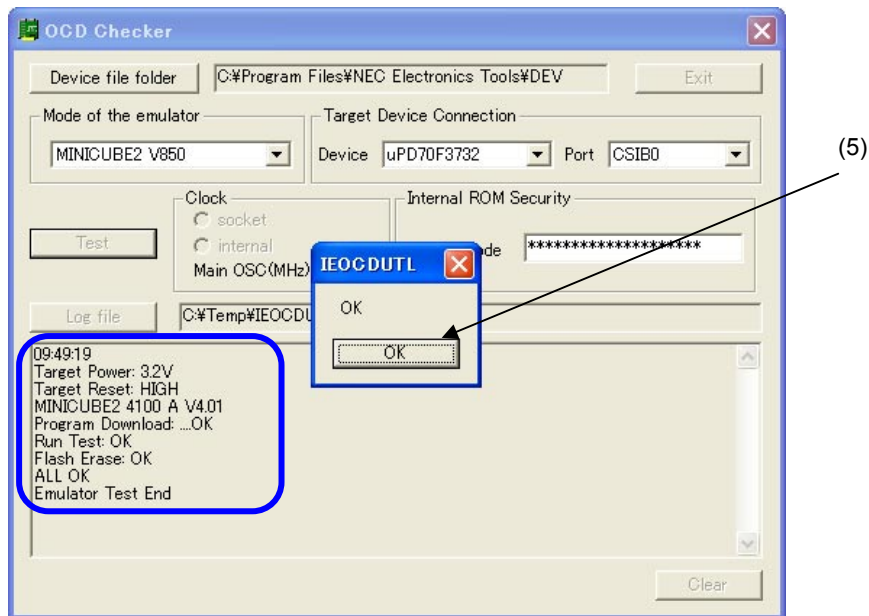

(6) Click the [Exit] button.

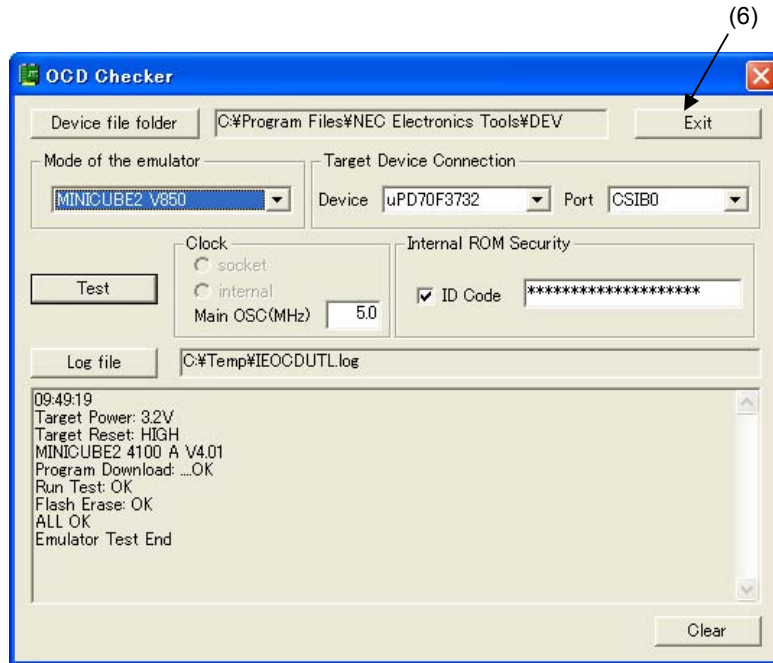

4.2 Format of Log File

The following shows an example of the log file when the check results show “OK” statuses.

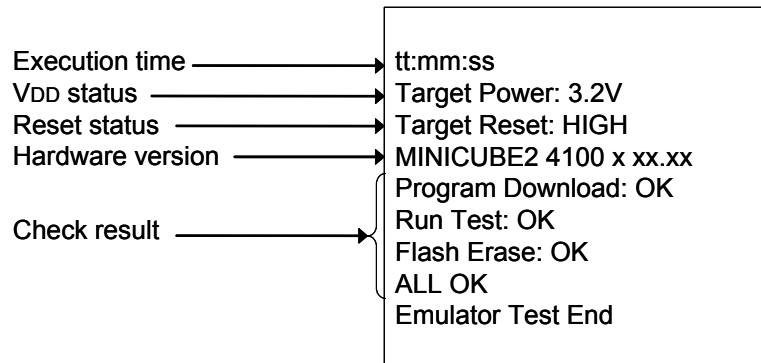

- Execution time: The time when checking was started by clicking the [Test] button
- V_{DD} status: V_{DD} value that is applied to the target device
- Reset status: RESET pin status
 - [HIGH] Reset signal input from the target system is HIGH
 - [LOW] Reset signal input from the target system is LOW
- Hardware version: Version of each hardware.
- Check result: [Program Download] ID verification, result of downloading to flash memory in the target device
 - [Run Test] Result of executing and stopping the program
 - [Flash Erase] Erasure result of flash memory in the target device

Remark The version of MINICUBE2 can also be checked with the MINICUBE2 diagnostic tool, debugger and QBP. The latest version of MINICUBE2 firmware can be checked on the following NEC Electronics websites.

Japanese version:

<http://www.necel.com/micro/ods/jpn/index.html>

English version:

<http://www.necel.com/micro/ods/eng/index.html>

See Version-up service → MINICUBE2_Software.

4.3 Error Output

The following describes the operation and display example when an NG is displayed as a result of **4.1 Execution of OCD Check**. The message just indicates “NG”, but there are various causes.

- (1) The result is displayed in the dialog box. Click the **[OK]** button.

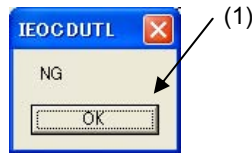

- (2) The contents displayed in the log view window are saved in the log file.
[Log view window]

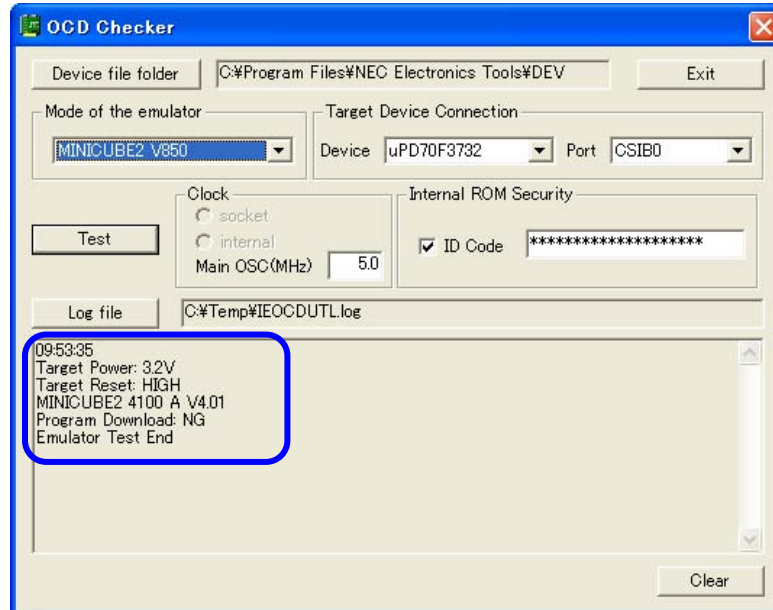

[Log file]

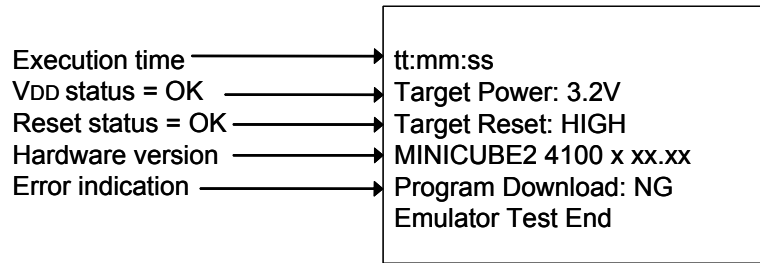

In this NG example, the error “Program Download” is detected.

An error during flash memory programming is detected. The cause is an error in pin connection on the board for connecting MINICUBE2 on the target system (pin 5 (SO) is shorted with GND).

4.4 Action for Error

The errors that may occur during self-testing (such as setting error) and relevant actions for coping with the errors are listed below.

If an error other than below is displayed, the cause may be a defect in MINICUBE2. If the same error is displayed even after the relevant action is implemented, the cause may be a defect in MINICUBE2. In such a case, consult an NEC Electronics sales representative or distributor.

(1/2)

No.	Error message and action
1	<p>Driver open error</p> <p>(1) There is no response from MINICUBE2. → Check the connections between the host machine and the USB cable, and the USB cable and the MINICUBE2. → Turn all the power supplies off according to the procedures described in the user’s manual. (MINICUBE2 is turned off by disconnecting the USB cable.) Turn all the power supplies on, and then click the [Test] button. If an error message is displayed even after taking these measures, restart Windows on the host machine before turning all the power supplies on.</p> <p>(2) The debugger has been started. → The debugger and the OCD Checker cannot be started simultaneously, so terminate the debugger.</p> <p>(3) The USB driver may not be operating normally. → Confirm the cable connection and the USB driver setup. Re-install the USB driver as necessary.</p> <p>(4) The debugger may not be installed normally. → Re-install the debugger.</p>
2	<p>Incorrect ID code</p> <p>The input ID code is incorrect. → Confirm the ID code written to the target device and re-input the ID code.</p>
3	<p>Log file write error</p> <p>The specified log file cannot be accessed. → Confirm that the folder, path, and file are write-enabled.</p>

No.	Error message and action
4	Cannot find monitor file
	Check if an unsupported device or unsupported port is selected.
5	Monitor Command(xxH) Error
	<p>Communication between the target device and MINICUBE2 has failed.</p> <p>→ The cause may be a problem in the electrical specifications of the cable or the target system, or the USB driver may not be operating normally.</p> <p>Confirm the connection and restart Windows on the host machine.</p>
6	Emulator Command(xxH) Error
	<p>Communication between the host machine and MINICUBE2 has failed.</p> <p>(1) Check the connections between the host machine and the USB cable, and the USB cable and the MINICUBE2.</p> <p>(2) Turn all the power supplies off according to the procedures described in the user's manual. (MINICUBE2 is turned off by disconnecting the USB cable.)</p> <p>Turn all the power supplies on, and then click the [Test] button.</p> <p>If an error message is displayed even after taking these measures, restart Windows on the host machine before turning all the power supplies on.</p>
7	Program Download : NG
	<p>An error occurred while writing to the flash memory.</p> <p>(1) Check if the items specified in the Target Device Connection area and clock select area satisfy the target device specifications.</p> <p>(2) Check the connections between the target device and MINICUBE2.</p> <p>(3) Check the power supply to the target system.</p> <p>(4) The cause may be the security flag setting, so clear the security flag setting via the flash memory programmer.</p> <p>(5) The target device may be damaged, so exchange the target device.</p> <p>(6) Check the MINICUBE2 settings.</p> <p>(7) Check the circuit for connecting MINICUBE2.</p>
8	Break Timeout, ERROR: Execute Break Test1, ERROR: Read Access Break Test, ERROR: Write Access Break Test, ERROR: Execute Break Test2
	The target device may be damaged, so exchange the target device.
9	Target Power : 0.0V [NG]
	<p>The power supply to the target system cannot be detected.</p> <p>→ Confirm that the power for the target system is on.</p> <p>→ Check the connection between the target system and MINICUBE2</p>
10	Use the firmware version Vx.xx or later
	Update MINICUBE2 firmware to Vx.xx or later.

CHAPTER 5 OCD CHECK FOR MINICUBE2 AND 78K0S MICROCONTROLLER

This section describes the method to check the connection between MINICUBE2 and the target system, which uses a 78K0S microcontroller as the target device, using the OCD Checker.

5.1 Execution of OCD Check

Be sure to terminate the debugger, QBP and MINICUBE2 diagnostic tool before executing the OCD Checker.

The 78K0-OCD board and 10-pin target cable (accessories of MINICUBE2) are not used.

Perform the connection check according to the following steps (1) to (6).

(1) MINICUBE2 setup

- Power select switch: Set the switch corresponding to the target system.
- Mode select switch: Set to "M2".
- Target cable: Connect the 16- pin target cable.

(2) Connection and power application

Connect MINICUBE2 to the target system in accordance with **MINICUBE2 User's Manual (U18371E)**, and the turn on power to the target system.

(3) Setting the OCD Checker

Refer to **2.3 Explanation of Each Area**.

- Emulator mode select area: Select "MINICUBE2 78K0S".
- Target Device Connection area: [Device] Select the target device to be connected from the drop-down list.
If the target device name is not displayed, specify the device file saving destination folder using the [Device file folder] button.
- [Log file] button: Specify the log file name and the location for saving the log file.

- (4) Click the [Test] button. If an error occurs during checking, refer to 5.3 Error Output and 5.4 Action for Error.

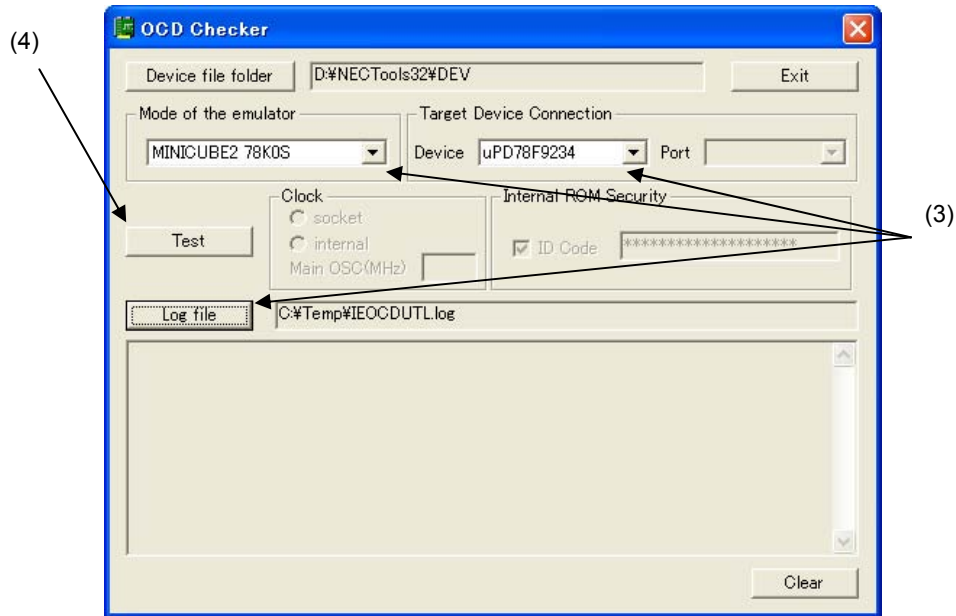

- (5) When all of the tests are complete, the result dialog box is displayed as shown below. The contents displayed in the log view window are saved in the log file. If an NG is displayed, refer to 5.3 Error Output and 5.4 Action for Error.

Click the [OK] button.

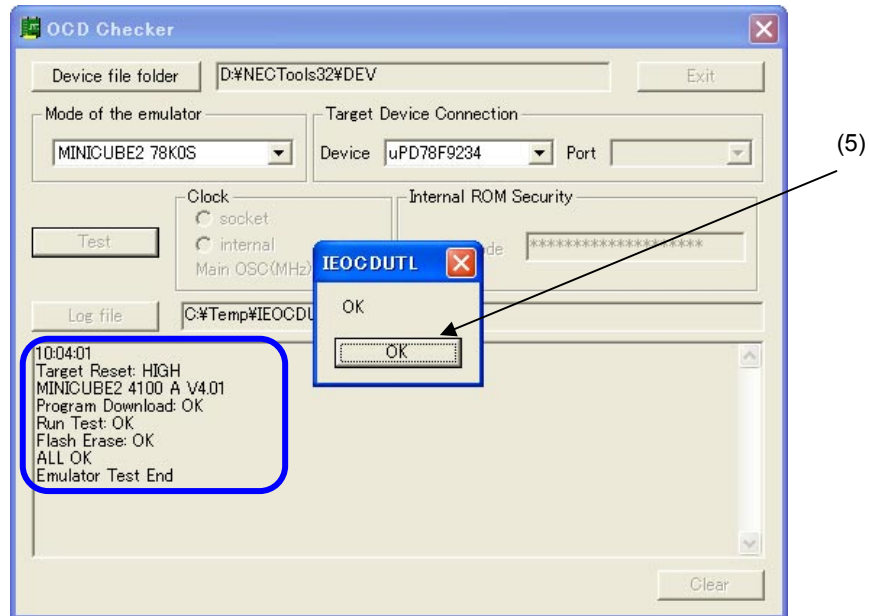

(6) Click the [Exit] button.

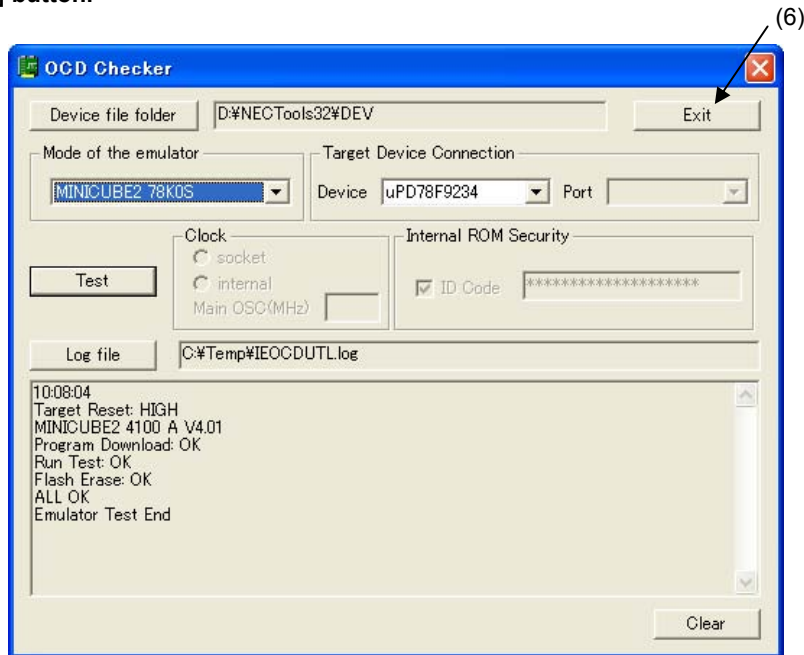

5.2 Format of Log File

The following shows an example of the log file when the check results show “OK” statuses.

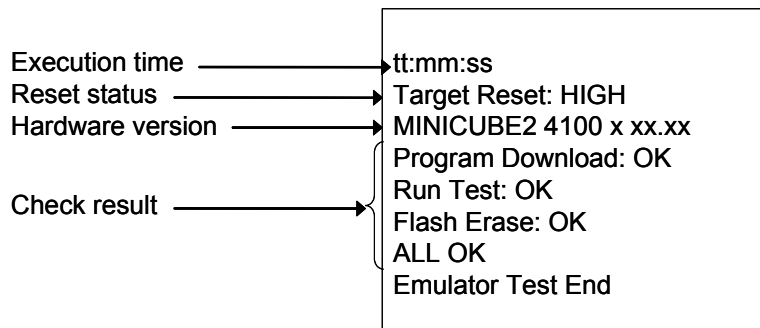

- Execution time: The time when checking was started by clicking the [Test] button
- Reset status: RESET pin status
 - [HIGH] Reset signal input from the target system is HIGH
 - [LOW] Reset signal input from the target system is LOW
- Hardware version: Version of each hardware.
- Check result: [Program Download] ID verification, result of downloading to flash memory in the target device
 - [Run Test] Result of executing and stopping the program
 - [Flash Erase] Erasure result of flash memory in the target device

Remark The version of MINICUBE2 can also be checked with the MINICUBE2 diagnostic tool, debugger and QBP. The latest version of MINICUBE2 firmware can be checked on the following NEC Electronics websites.

Japanese version:

<http://www.necel.com/micro/ods/jpn/index.html>

English version:

<http://www.necel.com/micro/ods/eng/index.html>

See Version-up service → MINICUBE2_Software.

5.3 Error Output

The following describes the operation and display example when an NG is displayed as a result of **5.1 Execution of OCD Check**. The message just indicates “NG”, but there are various causes.

- (1) The result is displayed in the dialog box. Click the **[OK]** button.



- (2) The contents displayed in the log view window are saved in the log file.
[Log view window]

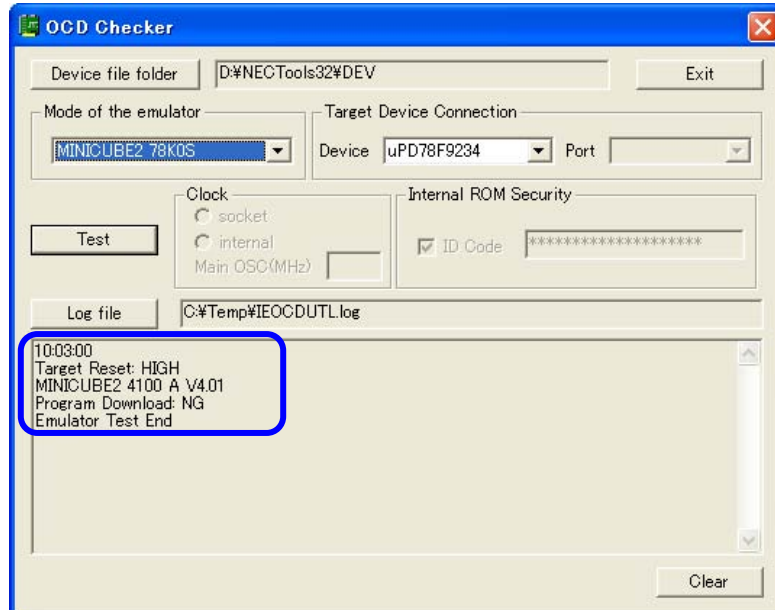

[Log file]

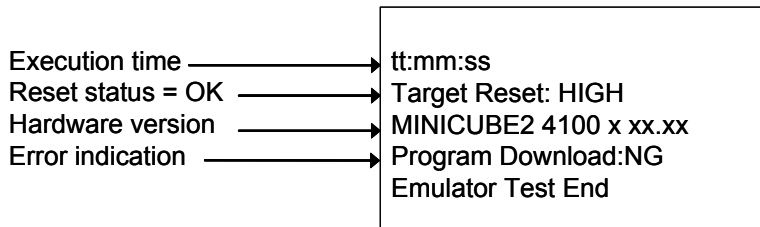

In this NG example, the error “Program Download” is detected.

An error during flash memory programming is detected. The cause is an error in pin connection on the board for connecting MINICUBE2 on the target system (pin 5 (SO) is shorted with GND).

5.4 Action for Error

The errors that may occur during self-testing (such as setting error) and relevant actions for coping with the errors are listed below.

If an error other than below is displayed, the cause may be a defect in MINICUBE2. If the same error is displayed even after the relevant action is implemented, the cause may be a defect in MINICUBE2. In such a case, consult an NEC Electronics sales representative or distributor.

(1/2)

No.	Error message and action
1	<p>Driver open error</p> <p>(1) There is no response from MINICUBE2. → Check the connections between the host machine and the USB cable, and the USB cable and the MINICUBE2. → Turn all the power supplies off according to the procedures described in the user’s manual. (MINICUBE2 is turned off by disconnecting the USB cable.) Turn all the power supplies on, and then click the [Test] button. If an error message is displayed even after taking these measures, restart Windows on the host machine before turning all the power supplies on.</p> <p>(2) The debugger has been started. → The debugger and the OCD Checker cannot be started simultaneously, so terminate the debugger.</p> <p>(3) The USB driver may not be operating normally. → Confirm the cable connection and the USB driver setup. Re-install the USB driver as necessary.</p> <p>(4) The debugger may not be installed normally. → Re-install the debugger.</p>
2	<p>Log file write error</p> <p>The specified log file cannot be accessed. → Confirm that the folder, path, and file are write-enabled.</p>
3	<p>Monitor Command(xxH) Error</p> <p>Communication between the target device and MINICUBE2 has failed. → The cause may be a problem in the electrical specifications of the cable or the target system, or the USB driver may not be operating normally. Confirm the connection and restart Windows on the host machine.</p>

No.	Error message and action
4	<p data-bbox="386 243 678 268">Emulator Command(xxH) Error</p> <p data-bbox="386 285 1052 310">Communication between the host machine and MINICUBE2 has failed.</p> <p data-bbox="386 327 1338 382">(1) Check the connections between the host machine and the USB cable, and the USB cable and the MINICUBE2.</p> <p data-bbox="386 399 1425 453">(2) Turn all the power supplies off according to the procedures described in the user's manual. (MINICUBE2 is turned off by disconnecting the USB cable.)</p> <p data-bbox="418 470 1013 495">Turn all the power supplies on, and then click the [Test] button.</p> <p data-bbox="418 512 1403 567">If an error message is displayed even after taking these measures, restart Windows on the host machine before turning all the power supplies on.</p> <p data-bbox="386 583 1396 638">(3) Check if the target device name matches the name specified in the [Device] drop-down list in the Target Device Connection area.</p>
5	<p data-bbox="386 653 623 678">Program Download : NG</p> <p data-bbox="386 695 873 720">An error occurred while writing to the flash memory.</p> <p data-bbox="386 737 1052 762">(1) Check the connections between the target device and MINICUBE2.</p> <p data-bbox="386 779 850 804">(2) Check the power supply to the target system.</p> <p data-bbox="386 821 1331 875">(3) The cause may be the security flag setting, so clear the security flag setting via the flash memory programmer.</p> <p data-bbox="386 892 1055 917">(4) The target device may be damaged, so exchange the target device.</p> <p data-bbox="386 934 721 959">(5) Check the MINICUBE2 settings.</p> <p data-bbox="386 976 844 1001">(6) Check the circuit for connecting MINICUBE2.</p>
6	<p data-bbox="386 1010 818 1035">Break Timeout, ERROR: Execute Break Test1</p> <p data-bbox="386 1052 1019 1077">The target device may be damaged, so exchange the target device.</p>
7	<p data-bbox="386 1094 753 1119">Use the firmware version Vx.xx or later</p> <p data-bbox="386 1136 824 1161">Update MINICUBE2 firmware to Vx.xx or later.</p>

CHAPTER 6 OCD CHECK FOR MINICUBE2 AND 78K0R MICROCONTROLLER

This section describes the method to check the connection between MINICUBE2 and the target system, which uses a 78K0R microcontroller as the target device, using the OCD Checker.

6.1 Execution of OCD Check

Be sure to terminate the debugger, QBP and MINICUBE2 diagnostic tool before executing the OCD Checker.

The 78K0-OCD board and 10-pin target cable (accessories of MINICUBE2) are not used.

Perform the connection check according to the following steps (1) to (6).

(1) MINICUBE2 setup

- Power select switch: Set the switch corresponding to the target system.
- Mode select switch: Set to "M1".
- Target cable: Connect the 16- pin target cable.

(2) Connection and power application

Connect MINICUBE2 to the target system in accordance with **MINICUBE2 User's Manual (U18371E)**, and the turn on power to the target system.

(3) Setting the OCD Checker

Refer to **2.3 Explanation of Each Area**.

- Emulator mode select area: Select "MINICUBE2 78K0R".
- Target Device Connection area: [Device] Select the target device to be connected from the drop-down list.
If the target device name is not displayed, specify the device file saving destination folder using the [Device file folder] button.
[Port] Select the mode for connection with target system from the drop-down list.
- Clock select area: Input the original main clock frequency in the "Main OSC(MHz)" text box.
- Internal ROM Security setting area: Input the ID code.
- [Log file] button: Specify the log file name and the location for saving the log file.

- (4) Click the **[Test]** button. If an error occurs during checking, refer to 6.3 **Error Output** and 6.4 **Action for Error**.

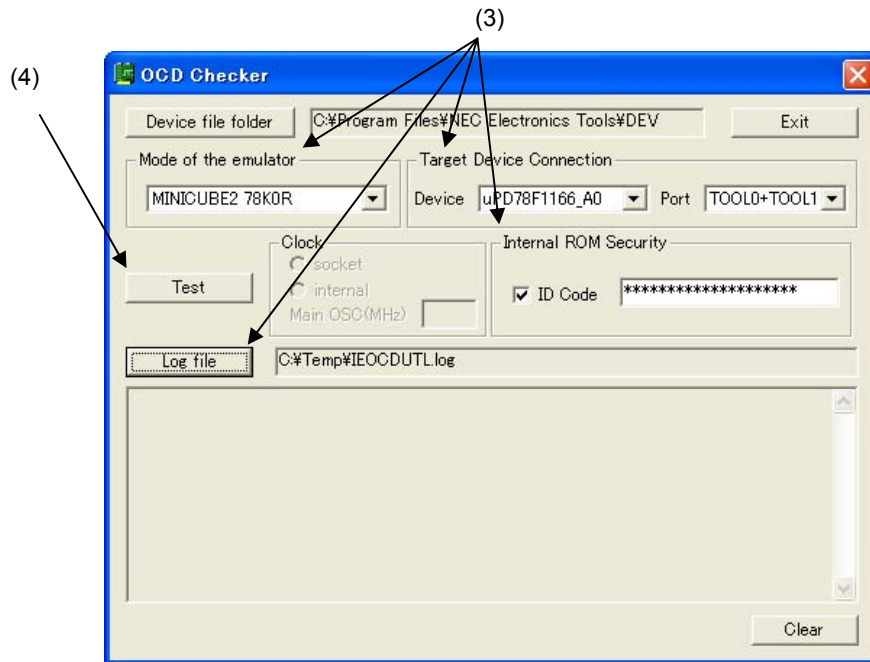

- (5) When all of the tests are complete, the result dialog box is displayed as shown below. The contents displayed in the log view window are saved in the log file. If an NG is displayed, refer to 6.3 **Error Output** and 6.4 **Action for Error**.

Click the **[OK]** button.

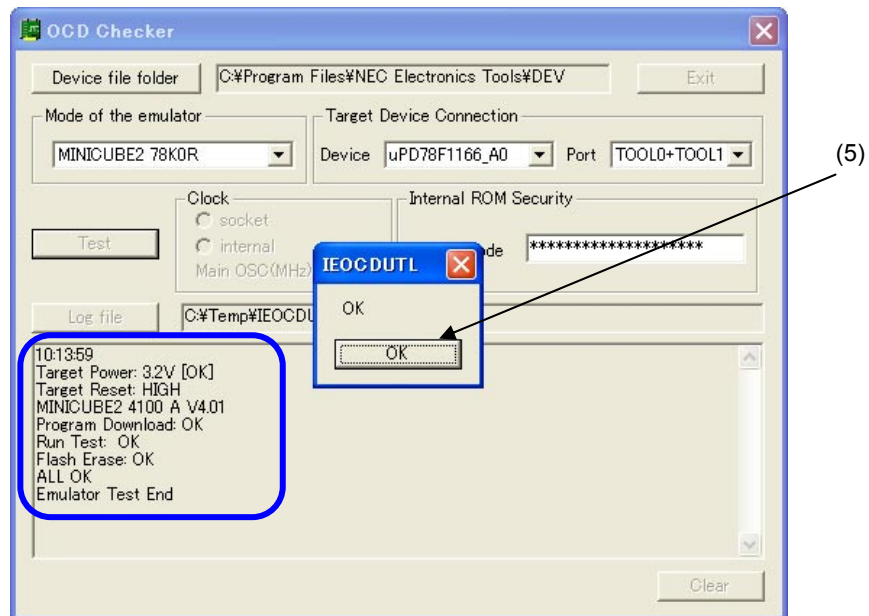

(6) Click the [Exit] button.

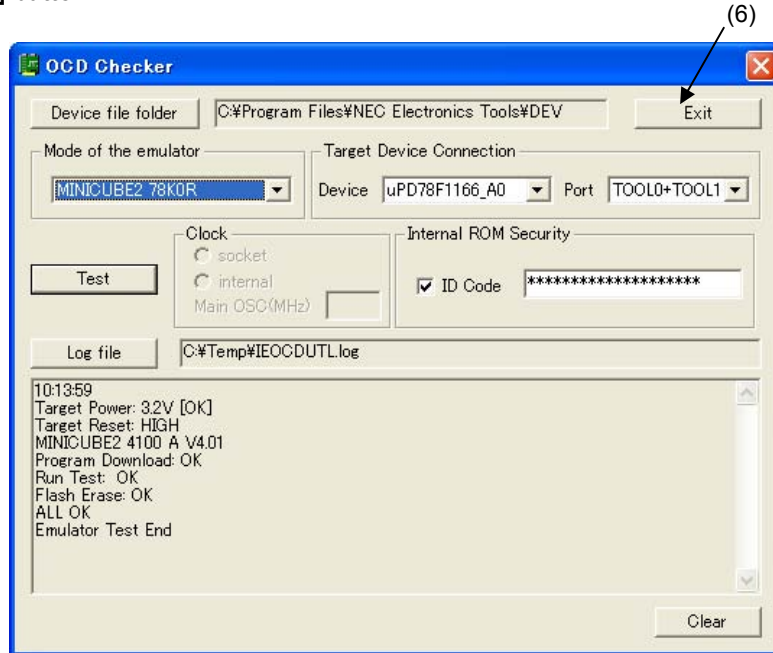

6.2 Format of Log File

The following shows an example of the log file when the check results show “OK” statuses.

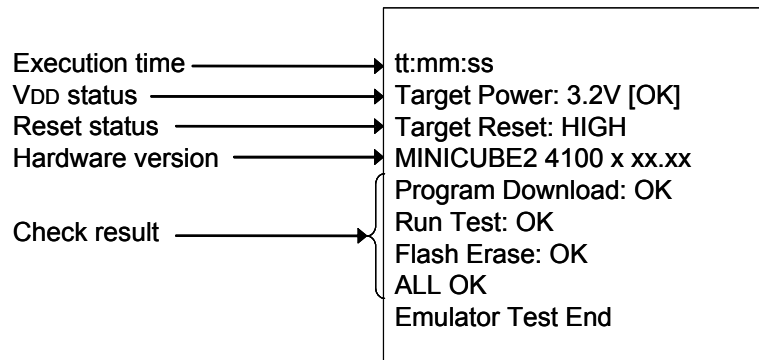

- Execution time: The time when checking was started by clicking the [Test] button
- V_{DD} status: V_{DD} value that is applied to the target device
- Reset status: $\overline{\text{RESET}}$ pin status
 - [HIGH] Reset signal input from the target system is HIGH
 - [LOW] Reset signal input from the target system is LOW
- Hardware version: Version of each hardware.
- Check result:
 - [Program Download] ID verification, result of downloading to flash memory in the target device
 - [Run Test] Result of executing and stopping the program
 - [Flash Erase] Erasure result of flash memory in the target device

Remark The version of MINICUBE2 can also be checked with the MINICUBE2 diagnostic tool, debugger and QBP. The latest version of MINICUBE2 firmware can be checked on the following NEC Electronics websites.

Japanese version:

<http://www.necel.com/micro/ods/jpn/index.html>

English version:

<http://www.necel.com/micro/ods/eng/index.html>

See Version-up service → MINICUBE2_Software.

6.3 Error Output

The following describes the operation and display example when an NG is displayed as a result of **6.1 Execution of OCD Check**. The message just indicates “NG”, but there are various causes.

(1) The result is displayed in the dialog box. Click the [OK] button.



(2) The contents displayed in the log view window are saved in the log file.

[Log view window]

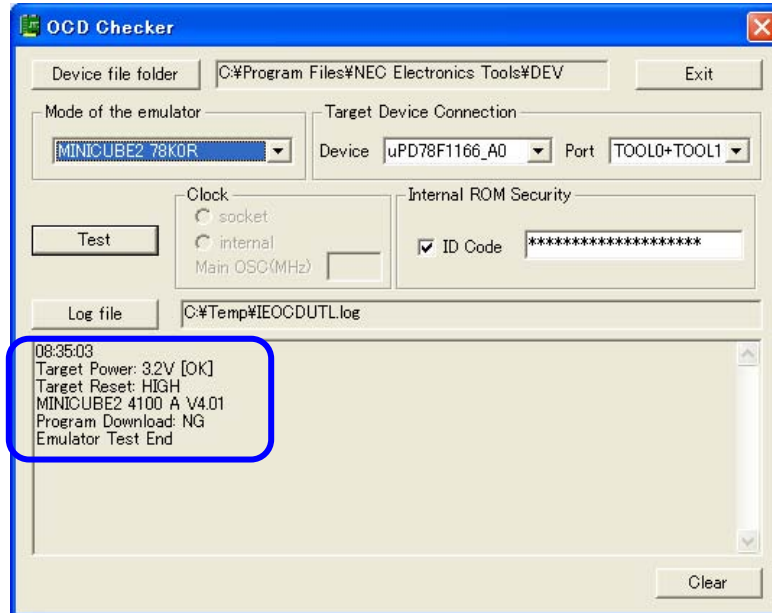

[Log file]

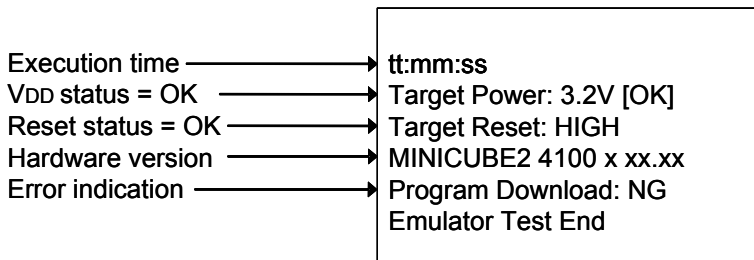

In this NG example, the error “Program Download” is detected.

An error during flash memory programming is detected. The cause is an error in pin connection on the board for connecting MINICUBE2 on the target system (pin 3 (RXD) is shorted with GND).

6.4 Action for Error

The errors that may occur during self-testing (such as setting error) and relevant actions for coping with the errors are listed below.

If an error other than below is displayed, the cause may be a defect in MINICUBE2. If the same error is displayed even after the relevant action is implemented, the cause may be a defect in MINICUBE2. In such a case, consult an NEC Electronics sales representative or distributor.

(1/2)

No.	Error message and action
1	Driver open error (1) There is no response from MINICUBE2. → Check the connections between the host machine and the USB cable, and the USB cable and the MINICUBE2. → Turn all the power supplies off according to the procedures described in the user’s manual. (MINICUBE2 is turned off by disconnecting the USB cable.) Turn all the power supplies on, and then click the [Test] button. If an error message is displayed even after taking these measures, restart Windows on the host machine before turning all the power supplies on. (2) The debugger has been started. → The debugger and the OCD Checker cannot be started simultaneously, so terminate the debugger. (3) The USB driver may not be operating normally. → Confirm the cable connection and the USB driver setup. Re-install the USB driver as necessary. (4) The debugger may not be installed normally. → Re-install the debugger.
2	Target Power : 0.0V [NG] The power supply to the target system cannot be detected. → Confirm that the power for the target system is on. → Check the connection between the target system and MINICUBE2
3	Incorrect ID code The input ID code is incorrect. → Confirm the ID code written to the target device and re-input the ID code.

No.	Error message and action
4	Log file write error
	The specified log file cannot be accessed. → Confirm that the folder, path, and file are write-enabled.
5	Monitor Command(xxH) Error
	Communication between the target device and MINICUBE2 has failed. → The cause may be a problem in the electrical specifications of the cable or the target system, or the USB driver may not be operating normally. Confirm the connection and restart Windows on the host machine.
6	Emulator Command(xxH) Error
	Communication between the host machine and MINICUBE2 has failed. (1) Check the connections between the host machine and the USB cable, and the USB cable and the MINICUBE2. (2) Turn all the power supplies off according to the procedures described in the user's manual. (MINICUBE2 is turned off by disconnecting the USB cable.) Turn all the power supplies on, and then click the [Test] button. If an error message is displayed even after taking these measures, restart Windows on the host machine before turning all the power supplies on. (3) Check if the target device name matches the name specified in the [Device] drop-down list in the Target Device Connection area.
7	Program Download : NG
	An error occurred while writing to the flash memory. (1) Check if the items specified in the Target Device Connection area and clock select area satisfy the target device specifications. (2) Check the connections between the target device and MINICUBE2. (3) Check the power supply to the target system. (4) The cause may be the security flag setting, so clear the security flag setting via the flash memory programmer. (5) The target device may be damaged, so exchange the target device. (6) Check the MINICUBE2 settings. (7) Check the circuit for connecting MINICUBE2.
8	Break Timeout, ERROR: Execute Break Test1
	The target device may be damaged, so exchange the target device.
9	Use the firmware version Vx.xx or later
	Update MINICUBE2 firmware to Vx.xx or later.

CHAPTER 7 OCD CHECK FOR 78K0 MINICUBE

This section describes the method to check the connection between the 78K0 MINICUBE and self-check board (accessory), using the OCD Checker.

7.1 Execution of OCD Check

Be sure to terminate the debugger before executing the OCD Checker.
Perform the connection check according to the following steps (1) to (4).

(1) Connection

Connect the 78K0 MINICUBE to the self-check board in accordance with the 78K0 MINICUBE user's manual.

(2) Setting the OCD Checker

Refer to **2.3 Explanation of Each Area**.

- Emulator mode select area: Select "78K0 MINICUBE".
- Clock select area: Select "internal" or "socket".
- Internal ROM Security setting area: Input the ID code.
- [Log file] button: Specify the log file name and the location for saving the log file.

(3) Click the [Test] button. If an error occurs during checking, refer to **7.3 Error Output** and **7.4 Action for Error**.

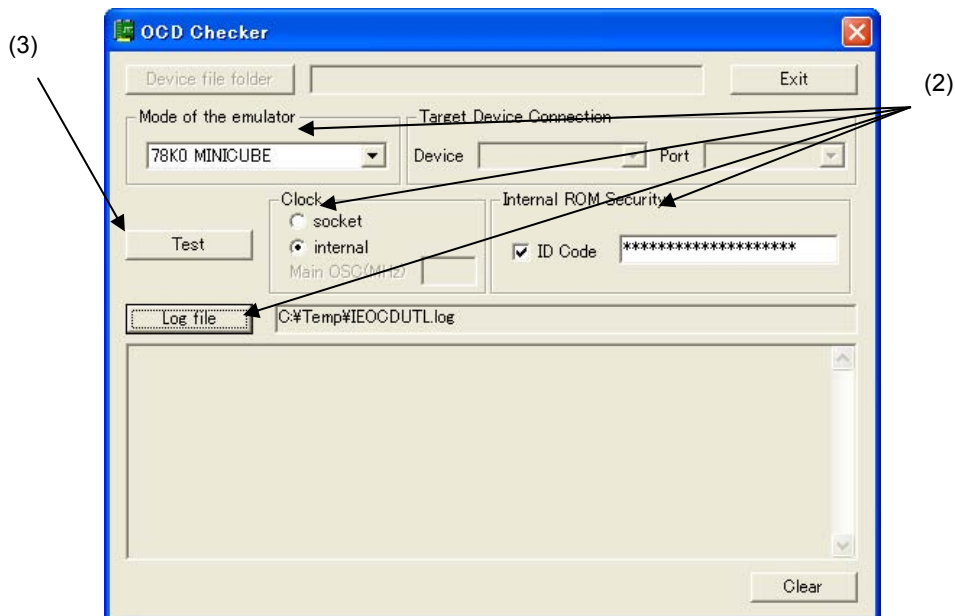

- (4) When all of the tests are complete, the result dialog box is displayed as shown below. The contents displayed in the log view window are saved in the log file. If an NG is displayed, refer to 7.3 Error Output and 7.4 Action for Error.

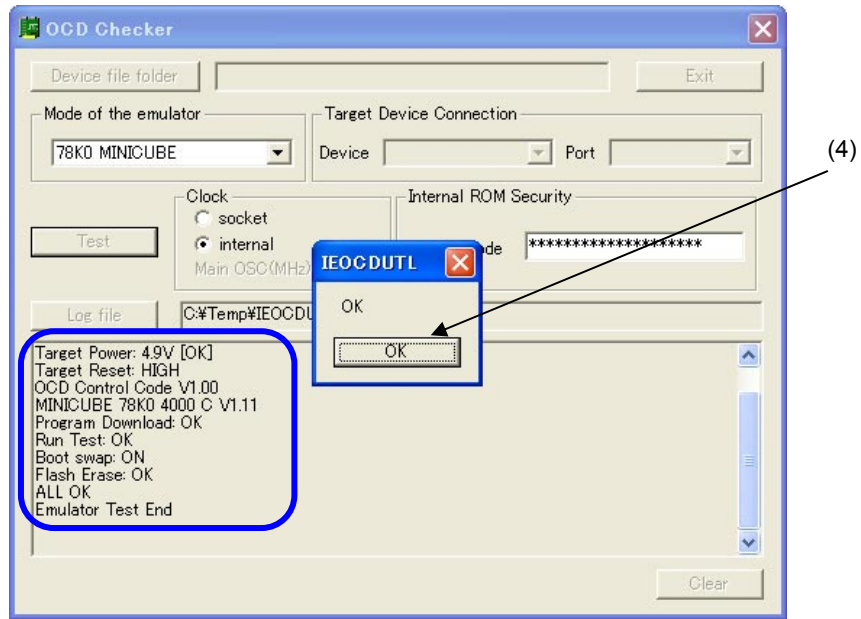

- (5) Click the [Exit] button.

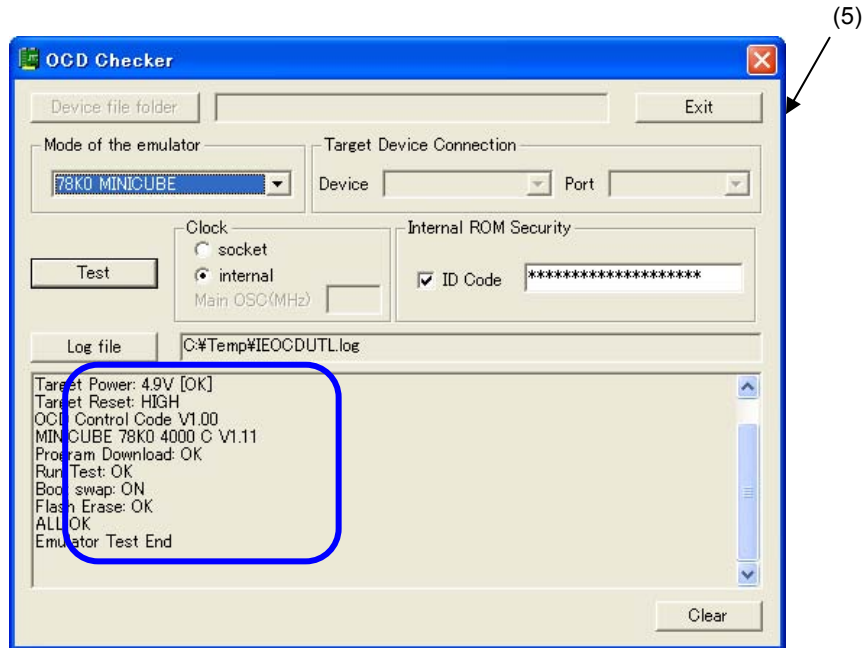

7.2 Format of Log File

The following shows an example of the log file.

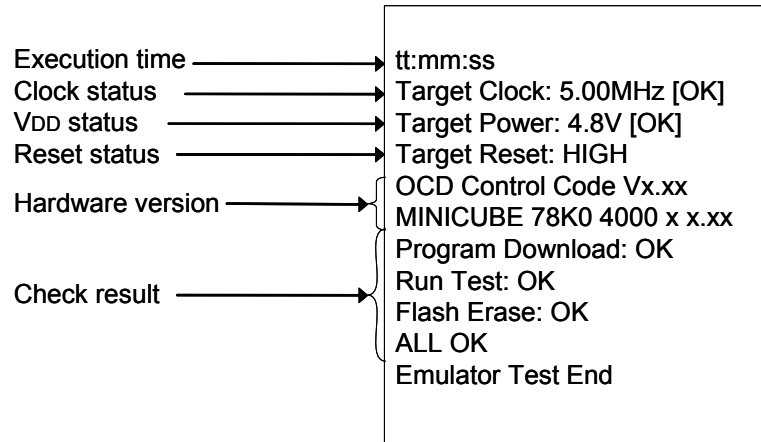

- Execution time: The time when checking was started by clicking the [Test] button.
- Clock status: Frequency of the selected clock
- V_{DD} status: V_{DD} value that is applied to the self-check board
- Reset status: RESET pin status
 - [HIGH] Reset signal input from the self-check board is HIGH
 - [LOW] Reset signal input from the self-check board is LOW
- Hardware version: Version of each hardware.
- Check result: [Program Download] ID verification, result of downloading to flash memory in the target device (self-check board)
 - [Run Test] Result of executing and stopping the program
 - [Flash Erase] Erasure result of flash memory in the target device (self-check board)

Remark The version of the 78K0 MINICUBE can also be checked with the debugger. For the latest version, consult an NEC Electronics sales representative or distributor. See **QB-78K0MINI User's Manual (U17029E)** for the control code of the OCD Checker.

7.3 Error Output

The following describes the operation and display example when an NG is displayed as a result of 7.1 Execution of OCD Check. The message just indicates “NG”, but there are various causes.

- (1) The result is displayed in the dialog box. Click the [OK] button.

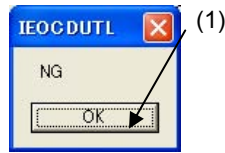

- (2) The contents displayed in the log view window are saved in the log file.
[Log view window]

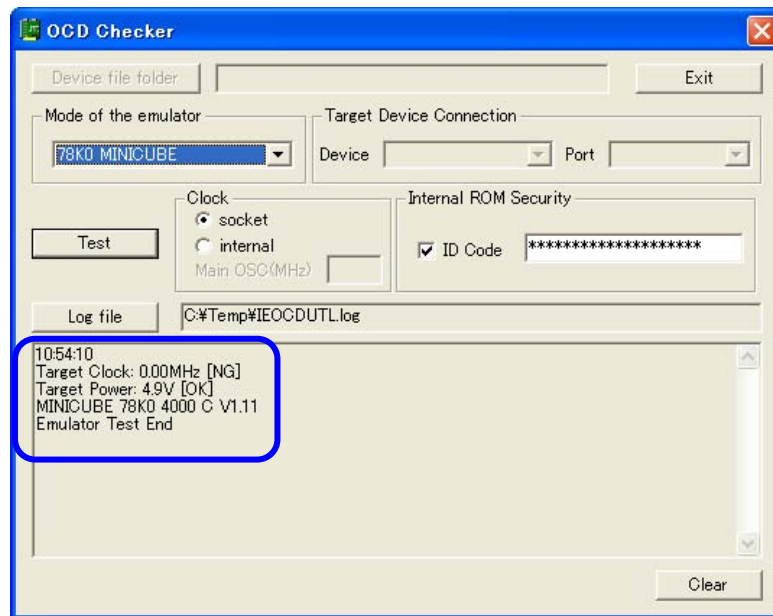

[Log file]

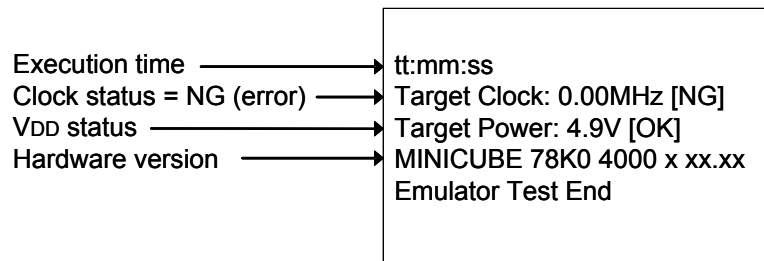

In this NG example, the clock status 0.00MHz is detected as an error.

The clock frequency 0.00 MHz is detected. This is because no oscillator is mounted in the CLK1 socket but “socket” is selected in the clock select area.

7.4 Action for Error

The errors that may occur during self-testing (such as setting error) and relevant actions for coping with the errors are listed below.

If an error other than below is displayed, the cause may be a defect in 78K0 MINICUBE. If the same error is displayed even after the relevant action is implemented, the cause may be a defect in the 78K0 MINICUBE. In such a case, consult an NEC Electronics sales representative or distributor.

(1/2)

No.	Error message and action
1	Communication error
	<p>There is no response from the target device.</p> <p>→ Address 0x84 (on-chip debug emulator use enable flag) is set to 0x00 (disable use) or the self-check board and MINICUBE are not connected correctly.</p> <p>Confirm the file of the program written to the self-check board and connection between the self-check board and MINICUBE.</p>
2	Target Power : OFF
	<p>The power supply to the self-check board cannot be detected.</p> <p>→ Confirm that LED1 on the self-check board glows.</p> <p>→ Check the connection between the self-check board and MINICUBE</p>
3	Target Clock: 0.00MHz [NG]
	<p>The clock mounted in the CLK1 socket may not be operating.</p> <p>→ Confirm the clock oscillation, or remove the clock mounted in the CLK1 socket and use the internal clock.</p>
4	Select Socket Clock
	<p>The clock mounted in the CLK1 socket is not selected.</p> <p>→ Select "socket" for the clock setting, or remove the clock mounted in the CLK1 socket and select "internal".</p>
5	Driver open error
	<p>(1) There is no response from the 78K0 MINICUBE.</p> <p>→ Check the connections between the host machine and the USB cable, and the USB cable and the 78K0 MINICUBE.</p> <p>→ Turn all the power supplies off according to the procedures described in the user's manual. (The 78K0 MINICUBE is turned off by disconnecting the USB cable.)</p> <p>Turn all the power supplies on, and then click the [Test] button.</p> <p>If an error message is displayed even after taking these measures, restart Windows on the host machine before turning all the power supplies on.</p> <p>(2) The debugger has been started.</p> <p>→ The debugger and the OCD Checker cannot be started simultaneously, so terminate the debugger.</p> <p>(3) The USB driver may not be operating normally.</p> <p>→ Confirm the cable connection and the USB driver setup. Re-install the USB driver as necessary.</p> <p>(4) The debugger may not be installed normally.</p> <p>→ Re-install the debugger.</p>
6	Incorrect ID code
	<p>The input ID code is incorrect.</p> <p>→ Confirm the ID code written to the target device and re-input the ID code.</p>

No.	Error message and action
7	<p>Log file write error</p> <p>The specified log file cannot be accessed. → Confirm that the folder, path, and file are write-enabled.</p>
8	<p>Test Rom Command(xxH) Error, Monitor Command(xxH) Error</p> <p>Communication between the target device on the self-check board and MINICUBE has failed. → The cause may be a problem in the electrical specifications of the cable or the self-check board, or the USB driver may not be operating normally. Confirm the connection and restart Windows on the host machine.</p>
9	<p>Write Memory, Read Memory, Data verify error</p> <p>The internal RAM cannot be accessed. The target device on the self-check board may be damaged. → Exchange the target device.</p>
10	<p>_Flash Env Error, _Flash Get Info Error, _Flash Block Blank Check Error, _Flash Block Erase Error, _Flash Word Write Error, _Flash Block Verify Error, _Flash Word Read Error, Data Verify Error</p> <p>An error occurred while writing to the flash memory. → The cause may be the security flag setting, so clear the security flag setting via the QBP. The target device on the self-check board may be damaged, so exchange the target device.</p>
11	<p>Break Timeout, ERROR: SP Break Test, ERROR: Execute Break Test1, ERROR: SFR Access Break Test, ERROR: Read Access Break Test1, ERROR: Read Access Break Test2, ERROR: Write Access Break Test1, ERROR: Write Access Break Test2, ERROR: Step Break Test, ERROR: Execute Break Test2</p> <p>The target device on the self-check board may be damaged, so exchange the target device.</p>

CHAPTER 8 OCD CHECK FOR 78K0S MINICUBE+

This section describes the method to perform a simple test based on checking the connection between the QB-78K0SMINI and QB-78K0SKX1-DA of the 78K0S MINICUBE+, using the OCD Checker.

8.1 Execution of OCD Check

Be sure to terminate the debugger before executing the OCD Checker.

(1) Connection and power application

Connect the 78K0S MINICUBE+ (with QB-78K0SMINI and QB-78K0SKX1-DA connected) or 78K0S MINICUBE+ to the target system in accordance with **QB-78K0SKX1MINI User's Manual (U17272E)**.

(2) Setting the OCD Checker

Refer to **2.3 Explanation of Each Area**.

- Emulator mode select area: Select "78K0S MINICUBE+".
- Clock select area: Select "internal" or "socket".
- [Log file] button: Specify the log file name and the location for saving the log file.

(3) Click the [Test] button. If an error occurs during checking, refer to **8.3 Error Output** and **8.4 Action for Error**.

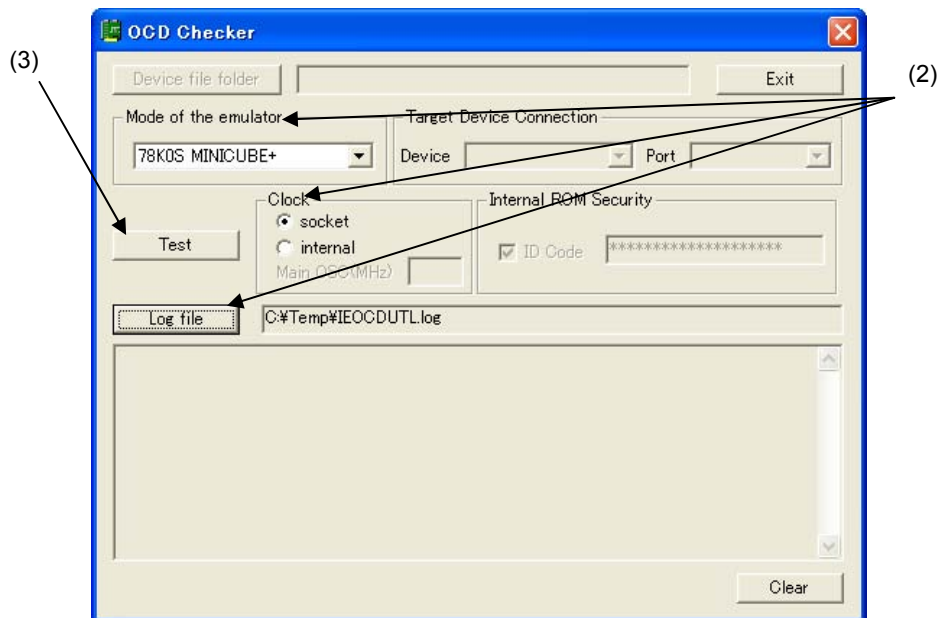

- (4) When all of the tests are complete, the result dialog box is displayed as shown below. The contents displayed in the log view window are saved in the log file. If an NG is displayed, **8.3 Error Output** and **8.4 Action for Error**.

Click the [OK] button.

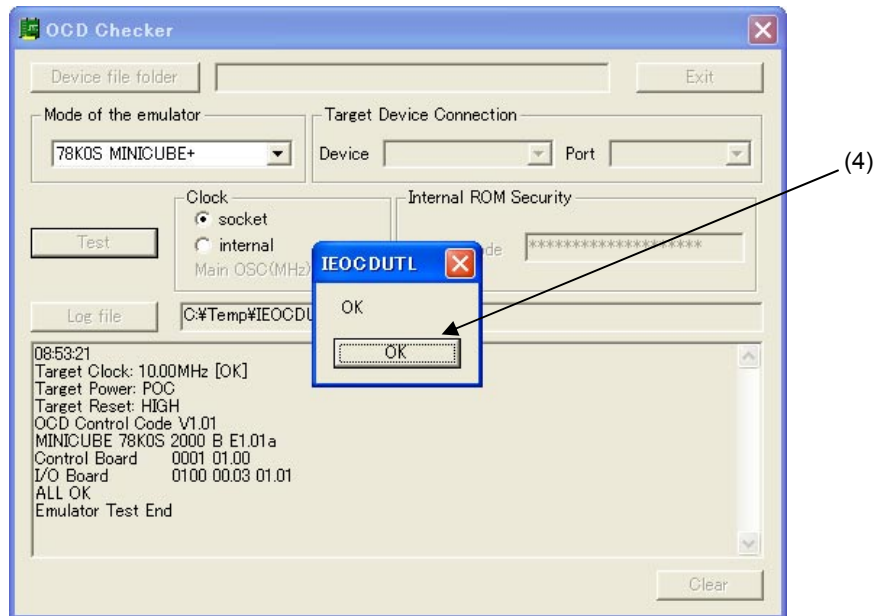

- (5) Click the [Exit] button.

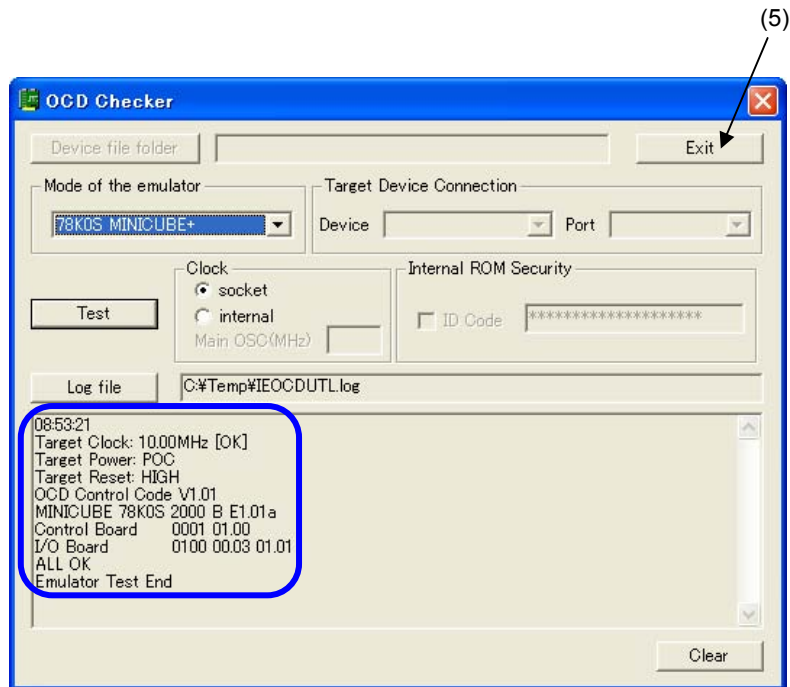

8.2 Format of Log File

The following shows an example of the log file when the check results show "OK" statuses.

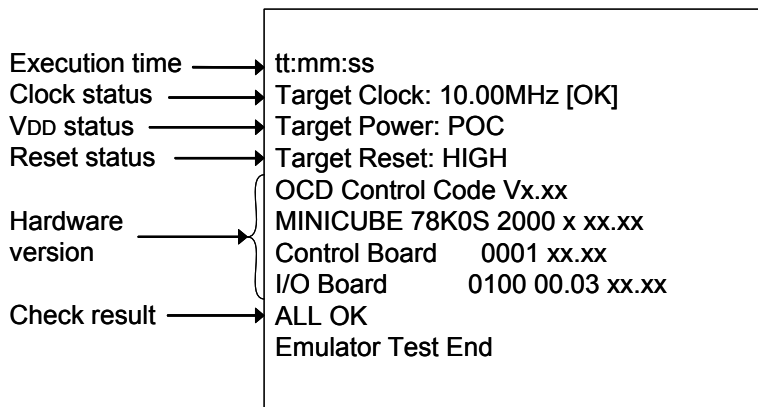

- Execution time: The time when checking was started by clicking the [Test] button.
- Clock status: Frequency of the selected clock
- V_{DD} status:
 - [ON] Power supply to the QB-78K0SKX1-DA and target system are on
 - [POC] Power supply to the QB-78K0SKX1-DA is on and power supply to the target system is off
 - [OFF] Power supply to the QB-78K0SKX1-DA is off (NG)
- Reset status: $\overline{\text{RESET}}$ pin status
 - [HIGH] Reset signal input from the target system is HIGH
 - [LOW] Reset signal input from the target system is LOW
- Hardware version: Version of each hardware.

Remark The version of the 78K0S MINICUBE+ can be checked on the following NEC Electronics websites. For the latest version, consult an NEC Electronics sales representative or distributor.

Japanese version:

<http://www.necel.com/micro/ods/jpn/index.html>

English version:

<http://www.necel.com/micro/ods/eng/index.html>

See Version-up service → MINICUBE2_Software.

8.3 Error Output

The following describes the operation and display example when an NG is displayed as a result of **8.1 Execution of OCD Check**. The message just indicates “NG”, but there are various causes.

- (1) The result is displayed in the dialog box. Click the [OK] button.

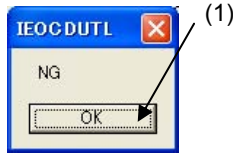

- (2) The contents displayed in the log view window are saved in the log file.

[Log view window]

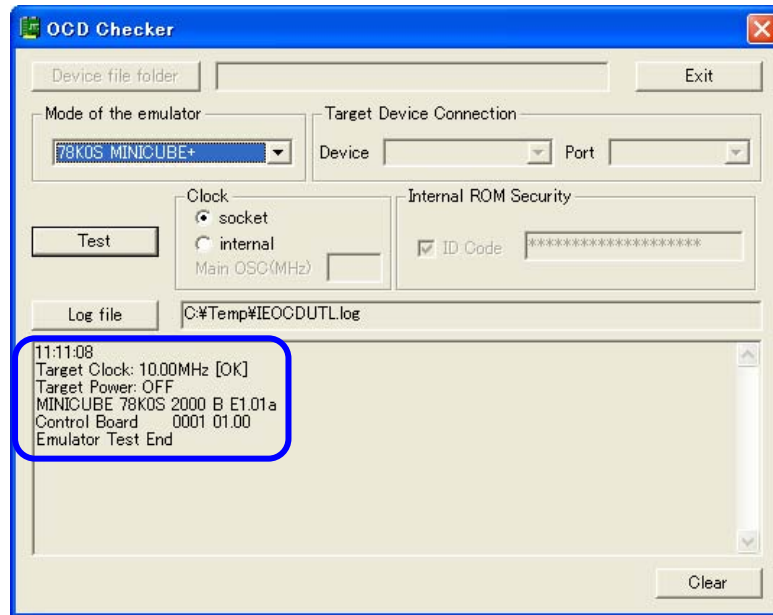

[Log file]

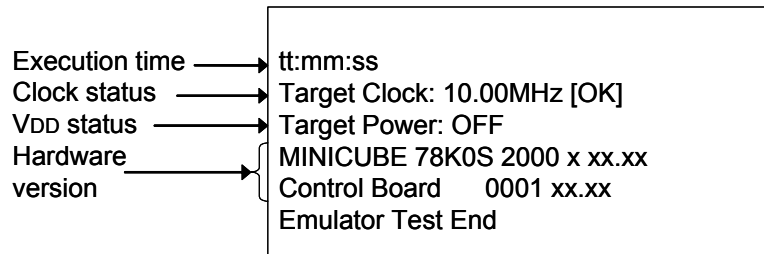

In this NG example, the error “Target Power: OFF” is detected.

Shutdown of the power supplied to the QB-78K0SKX1-DA is detected. This is because the check is performed without turning on the power to the QB-78K0SKX1-DA.

8.4 Action for Error

The errors that may occur during self-testing (such as setting error) and relevant actions for coping with the errors are listed below.

If an error other than below is displayed, the cause may be a defect in the 78K0S MINICUBE+. If the same error is displayed even after the relevant action is implemented, the cause may be a defect in the 78K0S MINICUBE+. In such a case, consult an NEC Electronics sales representative or distributor.

(1/2)

No.	Error message and action
1	Communication Error
	There is no response from the QB-78K0SKX1-DA. → Check the connection between the OCD I/F board or OCD I/F cable and the QB-78K0SKX1-DA and QB-78K0SMINI.
2	Target Power : OFF
	The power supply to the QB-78K0SKX1-DA cannot be detected. → Confirm that the power switch on the QB-78K0SKX1-DA is turned on. → Check the connection between the OCD I/F board or OCD I/F cable and the QB-78K0SKX1-DA and QB-78K0SMINI.
3	Target Clock: 0.00MHz [NG]
	The clock mounted in the CLK1 socket may not be operating. → Confirm the clock oscillation, or remove the clock mounted in the CLK1 socket and use the internal clock.
4	Select Socket Clock
	The clock mounted in the CLK1 socket is not selected. → Select "socket" for the clock selection, or remove the clock mounted in the CLK1 socket and select "internal".
5	Driver Open Error
	(1) There is no response from the 78K0S MINICUBE+. → Check the connections between the host machine and the USB cable, and the USB cable and the QB-78K0SMINI. → Turn all the power supplies off according to the procedures described in the user's manual. (The QB-78K0SMINI is turned off by disconnecting the USB cable.) Turn all the power supplies on, and then click the [Test] button. If an error message is displayed even after taking these measures, restart Windows on the host machine before turning all the power supplies on. (2) The debugger has been started. → The debugger and the OCD Checker cannot be started simultaneously, so terminate the debugger. (3) The USB driver may not be operating normally. → Confirm the cable connection and the USB driver setup. Re-install the USB driver as necessary. (4) The debugger may not be installed normally. → Re-install the debugger.

(2/2)

No.	Error message and action
6	<p data-bbox="386 241 558 268">Log file write error</p> <p data-bbox="386 283 570 310">The cause may be:</p> <p data-bbox="386 323 781 350">The specified log file cannot be accessed.</p> <p data-bbox="386 363 932 390">→ Confirm that the folder, path, and file are write-enabled.</p>
7	<p data-bbox="386 403 976 430">Test Rom Command(xxH) Error, Monitor Command(xxH) Error</p> <p data-bbox="386 445 1133 472">Communication between the QB-78K0SKX1-DA and QB-78K0SMINI has failed.</p> <p data-bbox="386 485 1442 546">→ The cause may be a problem in the electrical specifications of the cable or the target board, or the USB driver may not be operating normally.</p> <p data-bbox="412 558 1032 585">Confirm the connection and restart Windows on the host machine.</p>

CHAPTER 9 OCD CHECKER VERSION INDICATION

This section describes the method to check the version.

Click the icon on the title bar or right-click the title bar; the system menu is then displayed.

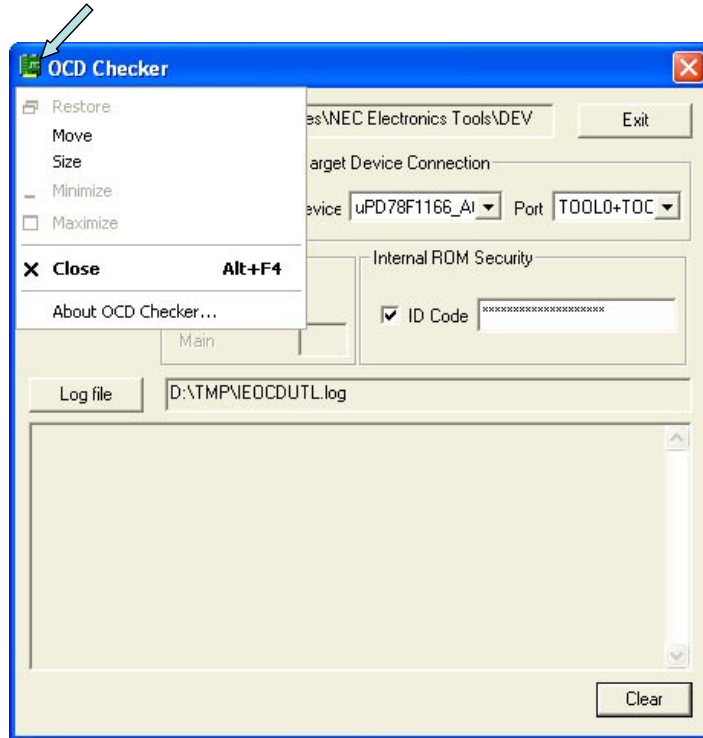

Click "About OCD Checker..." on the system menu; the version information window then appears.

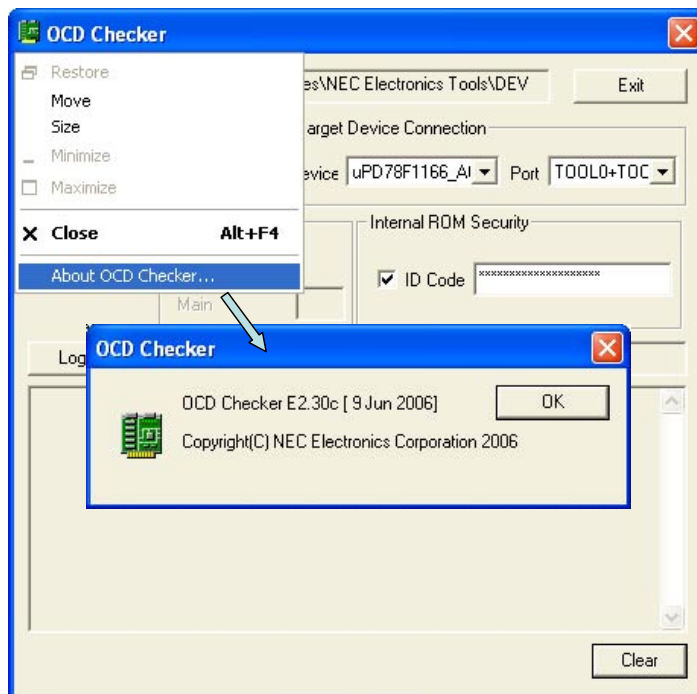

CHAPTER 10 UNINSTALLATION

This section explains how to uninstall the OCD Checker.

Note the following points when uninstalling the OCD Checker.

- The MINICUBE2 diagnostic tool is uninstalled at the same time.
- The log files are not deleted by uninstalling the OCD Checker.

Perform uninstallation according to the following steps (1) to (5).

- (1) Turn on power to the host machine and start Windows.
- (2) Start "Add/Remove Programs" or "Add or Remove Programs" in the Control Panel.
- (3) Select the relevant item from the list displayed on the Install/Uninstall tab, and then click the **[Add/Remove...]** or **[Change/Remove] button**.
 - To uninstall the OCD Checker: "NEC EL MINICUBE Utilities Vx.xx"
 - To uninstall this document: "NEC EL MINICUBE Utilities Vx.xx Documents"
- (4) A dialog box for confirming deletion of files will be displayed. Click the **[Yes] button**, deleting the files will then be started.
- (5) When the completion message is displayed, click the **[OK] button**. This completes uninstalling the OCD Checker.

<R>

APPENDIX A REVISION HISTORY

A.1 Major Revisions in This Edition

Page	Description
CHAPTER 2 INSTALLATION AND STARTUP	
p.10	Addition of description in 2.1.1 Installation
	Addition of description in 2.1.2 Startup
APPENDIX A REVISION HISTORY	
p.52	Addition of APPENDIX A REVISION HISTORY

[MEMO]

[MEMO]

[MEMO]

*For further information,
please contact:*

NEC Electronics Corporation
1753, Shimonumabe, Nakahara-ku,
Kawasaki, Kanagawa 211-8668,
Japan
Tel: 044-435-5111
<http://www.necel.com/>

[America]

NEC Electronics America, Inc.
2880 Scott Blvd.
Santa Clara, CA 95050-2554, U.S.A.
Tel: 408-588-6000
800-366-9782
<http://www.am.necel.com/>

[Europe]

NEC Electronics (Europe) GmbH
Arcadiastrasse 10
40472 Düsseldorf, Germany
Tel: 0211-65030
<http://www.eu.necel.com/>

Hanover Office

Podbielskistrasse 166 B
30177 Hannover
Tel: 0 511 33 40 2-0

Munich Office

Werner-Eckert-Strasse 9
81829 München
Tel: 0 89 92 10 03-0

Stuttgart Office

Industriestrasse 3
70565 Stuttgart
Tel: 0 711 99 01 0-0

United Kingdom Branch

Cygnus House, Sunrise Parkway
Linford Wood, Milton Keynes
MK14 6NP, U.K.
Tel: 01908-691-133

Succursale Française

9, rue Paul Dautier, B.P. 52
78142 Velizy-Villacoublay Cédex
France
Tel: 01-3067-5800

Sucursal en España

Juan Esplandiu, 15
28007 Madrid, Spain
Tel: 091-504-2787

Tyskland Filial

Täby Centrum
Entrance S (7th floor)
18322 Täby, Sweden
Tel: 08 638 72 00

Filiale Italiana

Via Fabio Filzi, 25/A
20124 Milano, Italy
Tel: 02-667541

Branch The Netherlands

Steijgerweg 6
5616 HS Eindhoven
The Netherlands
Tel: 040 265 40 10

[Asia & Oceania]

NEC Electronics (China) Co., Ltd
7th Floor, Quantum Plaza, No. 27 ZhiChunLu Haidian
District, Beijing 100083, P.R.China
Tel: 010-8235-1155
<http://www.cn.necel.com/>

Shanghai Branch

Room 2509-2510, Bank of China Tower,
200 Yincheng Road Central,
Pudong New Area, Shanghai, P.R.China P.C:200120
Tel:021-5888-5400
<http://www.cn.necel.com/>

Shenzhen Branch

Unit 01, 39/F, Excellence Times Square Building,
No. 4068 Yi Tian Road, Futian District, Shenzhen,
P.R.China P.C:518048
Tel:0755-8282-9800
<http://www.cn.necel.com/>

NEC Electronics Hong Kong Ltd.

Unit 1601-1613, 16/F., Tower 2, Grand Century Place,
193 Prince Edward Road West, Mongkok, Kowloon, Hong Kong
Tel: 2886-9318
<http://www.hk.necel.com/>

NEC Electronics Taiwan Ltd.

7F, No. 363 Fu Shing North Road
Taipei, Taiwan, R. O. C.
Tel: 02-8175-9600
<http://www.tw.necel.com/>

NEC Electronics Singapore Pte. Ltd.

238A Thomson Road,
#12-08 Novena Square,
Singapore 307684
Tel: 6253-8311
<http://www.sg.necel.com/>

NEC Electronics Korea Ltd.

11F., Samik Lavied'or Bldg., 720-2,
Yeoksam-Dong, Kangnam-Ku,
Seoul, 135-080, Korea
Tel: 02-558-3737
<http://www.kr.necel.com/>