

ISL95210EVAL1Z

ISL95210 10A Integrated FET Regulator Evaluation Board Setup Procedure

AN1485  
Rev 1.00  
November 30, 2011

This document describes the setup procedure for the ISL95210EVAL1Z Rev B board.

**Description**

Increasing demand for circuit board real estate necessitates the use of a higher integration to reduce component count. To that end, Intersil introduces the ISL95210 regulator. It features integrated power MOSFET switches that are capable of delivering 10A continuous load current at elevated temperatures and maintaining high efficiency. Leveraging a highly digital feature set and the new R4™ modulator allows the ISL95210 to provide a fully regulated point of load solution with only four external components. For more information on the features of the ISL95210, see the data sheet [FN6938](#)

**What's Inside**

The Evaluation Board Kit contains the following materials:

- ISL95210EVAL1Z REV B Board
- ISL95210 Data Sheet
- ISL95210 Evaluation Board Setup Procedure (this document)

**What's Needed**

The following materials will be needed to perform testing:

- +5V, 10A Power Supply
- Precision Digital Multi-Meter
- Electronic Load
- 4-Channel Oscilloscope

NOTE: Amperage rating of power supplies are determined by maximum expected loading plus a percentage margin of error.

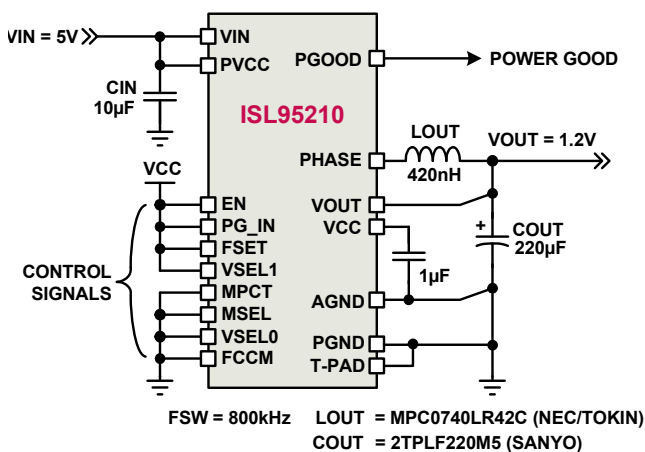

FIGURE 1. ISL95210 800kHz TYPICAL APPLICATION CIRCUIT

**Quick Setup Guide**

- Step 1: Set the +5.0V power supply to +5V and place in the "STANDBY" or "OFF" position. Connect the positive terminal (+) of the supply to the +5V terminal TP4 and the negative terminal (-) of the supply to GND TP3.
- Step 2: Connect the positive terminal (+) of the electronic load to the VOUT terminal TP1. Connect the negative terminal (-) of the electronic load to the GND terminal TP2. Make sure the electronic load is set to the 0A condition.
- Step 3: Check to ensure all jumpers and switches are in their default positions prior to application of power (refer to "Detailed Description of Switch Settings" and "Detailed Description of Jumper Settings" on page 2).
- Step 4: Set the power supply to the "ON" position. LED D1 should show Red. Check all power supply outputs with a DMM to ensure correct voltage levels. Adjust if necessary.
- Step 5: Move the ENABLE jumper to the "ON" position. LED D1 should show Green.
- Step 6: Measure VOUT with a DMM from TP5(+) to TP8(-). It should read 1.2V (±1%).

At this point, the board has been properly powered up. Normal testing can begin.

NOTE: If you need technical assistance, or other assistance, with the ISL95210 Evaluation Board, call 1-888-INTERSIL (468-3774).

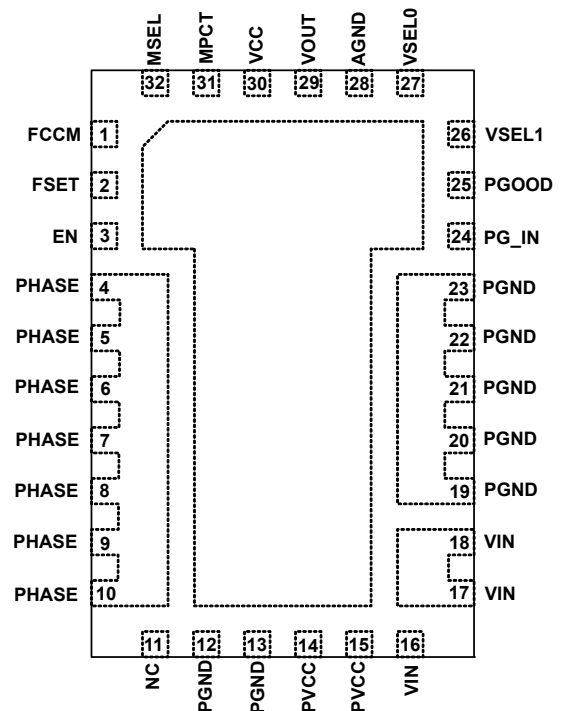

FIGURE 2. ISL95210 PINOUT 4x6mm 32 LD QFN (TOP VIEW)

### Detailed Description of Test Points

TEST POINT	FUNCTION
J1	V <sub>OUT</sub> Scope Probe Jack
J2	PHASE Scope Probe Jack
TP5	V <sub>OUT</sub>
TP6	GND (V <sub>IN</sub> )
TP7	V <sub>IN</sub>
TP8	GND (V <sub>OUT</sub> )
TP16	PG_IN (external source if J4 is OPEN)
TP17	PGOOD
TP18	+12V_AUX (if charge pump is disabled with J3)

### Detailed Description of Switch Settings

SWITCH	POSITION	FUNCTION
S1	OFF	ENABLE On-Board Load Transient

NOTE: The POSITION column reflects the default state of each switch or jumper.

### Detailed Description of Jumper Settings

JUMPER	POSITION	FUNCTION
S1	OFF	OFF = Regulator is disabled ON = Regulator is enabled
S2	ON	OFF = 400kHz operation FLOAT = 533kHz operation ON = 800kHz operation
S3	ON	OFF = Full DCM FLOAT = Ultra-sonic DCM ON = Full CCM
S4	OFF	OFF = ±15% margin setpoint FLOAT = ±10% margin setpoint ON = ±20% margin setpoint
S5	OFF	OFF = No margining FLOAT = Margin down ON = Margin up
S6	OFF	OFF = VSEL0 logic low FLOAT = VSEL0 floating ON = VSEL0 logic high
S7	ON	OFF = VSEL1 logic low FLOAT = VSEL1 floating ON = VSEL1 logic high
J3	CLOSED	CLOSED = LED and charge pump ON OPEN = LED and charge pump OFF
J4	CLOSED	CLOSED = LED and charge pump ON OPEN = LED and charge pump OFF

## ISL95210EVAL1Z Evaluation Board Schematics

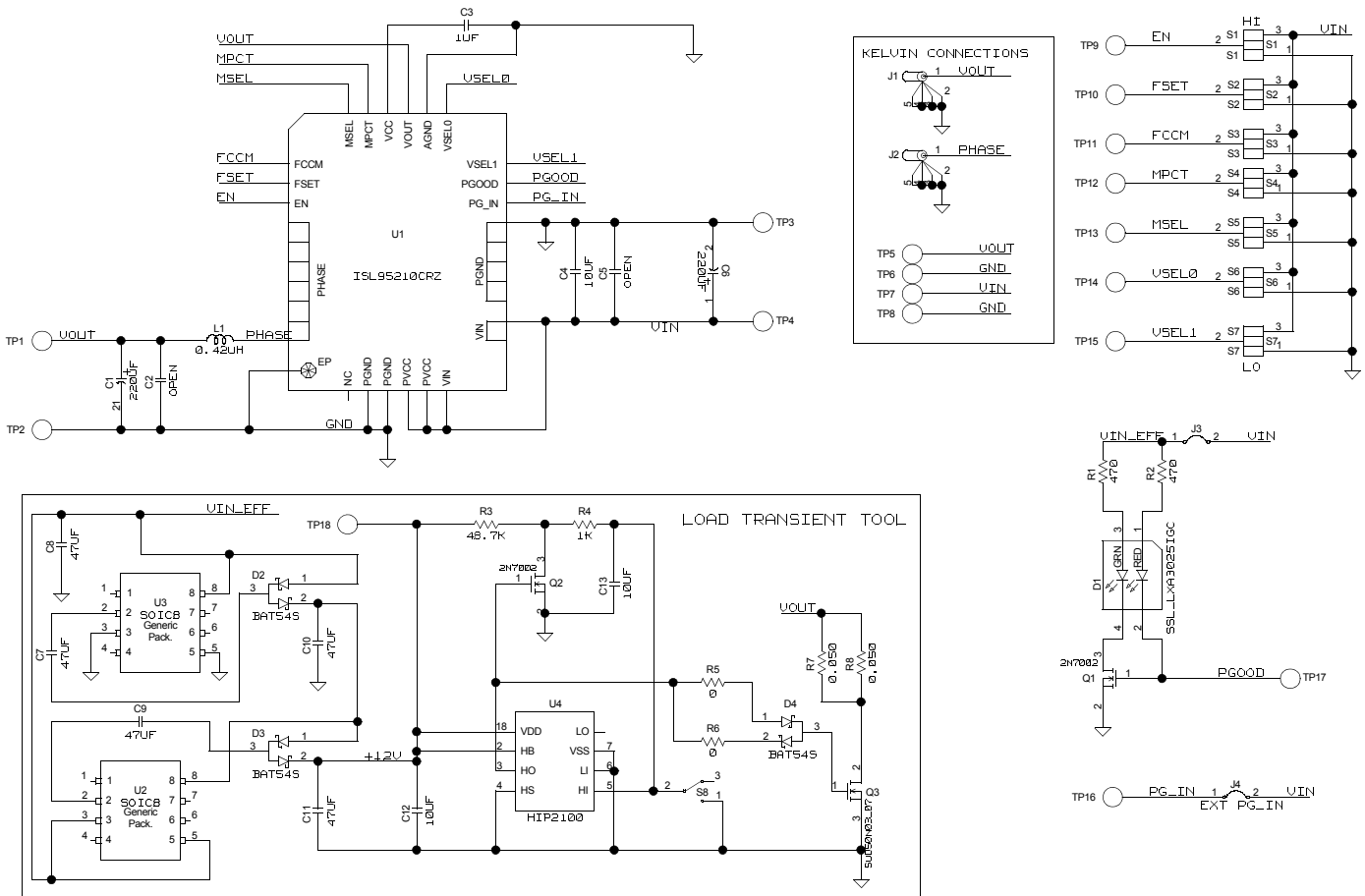

TABLE 1. BILL OF MATERIALS

ITEM	QTY	REFERENCE	VALUE	TYPE	FOOTPRINT	VOLTAGE (V)
<b>TOP LAYER</b>						
<b>1</b>	<b>1</b>	<b>C1</b>	<b>220<math>\mu</math>F</b>	<b>Sanyo-POSCAP 2TPLF220M5</b>		<b>2</b>
<b>2</b>	<b>1</b>	<b>C3</b>	<b>1<math>\mu</math>F</b>	<b>Generic MLCC X5R (or better)</b>	0603	<b>6.3</b>
<b>3</b>	<b>1</b>	<b>C4</b>	<b>10<math>\mu</math>F</b>	<b>Generic MLCC X5R (or better)</b>	1206	<b>6.3</b>
<b>4</b>	<b>1</b>	<b>L1</b>	<b>420nH</b>	<b>Tokin MPC0740LR42C</b>	2525	
<b>5</b>	<b>1</b>	<b>U1</b>		<b>ISL95210 10A Regulator</b>	4x6mm QFN	
<b>6</b>	<b>1</b>	<b>D1</b>		Lumex SSL_LXA3025IGC LED	3x2 5mm	
<b>7</b>	<b>1</b>	<b>S8</b>		C&K GT11MSCBE SPDT Switch		
<b>BOTTOM LAYER</b>						
<b>8</b>	<b>1</b>	<b>C2</b>	<b>DNP</b>			
<b>9</b>	<b>1</b>	<b>C5</b>	<b>DNP</b>			
<b>10</b>	<b>1</b>	<b>C6</b>	<b>330<math>\mu</math>F</b>	<b>Sanyo-POSCAP 6TPB330M</b>		<b>6.3</b>
<b>11</b>	<b>7</b>	<b>C7, C8, C9, C10, C11, C12, C13</b>	<b>10<math>\mu</math>F</b>	<b>Generic MLCC (X5R or better)</b>	0805	<b>16</b>
<b>12</b>	<b>2</b>	<b>R1, R2</b>	<b>470<math>\Omega</math></b>	<b>1% generic thick film chip resistor</b>	0603	
<b>13</b>	<b>1</b>	<b>R3</b>	<b>48.7k<math>\Omega</math></b>			
<b>14</b>	<b>1</b>	<b>R4</b>	<b>1k<math>\Omega</math></b>			
<b>15</b>	<b>2</b>	<b>R5, R6</b>	<b>249<math>\Omega</math></b>			
<b>16</b>	<b>1</b>	<b>R7</b>	<b>0.12<math>\Omega</math></b>		2512	
<b>17</b>	<b>1</b>	<b>R8</b>	<b>DNP</b>			
<b>18</b>	<b>3</b>	<b>D2, D3, D4</b>		<b>Generic BAT54S</b>	SOT-23	
<b>19</b>	<b>2</b>	<b>Q1, Q2</b>		<b>Generic 2N7002</b>	SOT-23	
<b>20</b>	<b>1</b>	<b>Q3</b>		<b>Vishay SUD50N03-07-E3</b>	TO-252	
<b>21</b>	<b>2</b>	<b>U2, U3</b>		<b>Intersil ICL7660 charge pump</b>	SOIC8	
<b>22</b>	<b>1</b>	<b>U4</b>		<b>Intersil HIP2100 half-bridge driver</b>	SOIC8	

## NOTES:

- Jumpers and test points not included in BOM as they represent non-critical components.
- Components in **BOLD** represent the required components for a real application. The remainder are for board flexibility and evaluation.

# ISL95210EVAL1Z Layout

Board consists of 4 layers of 2 ounce copper

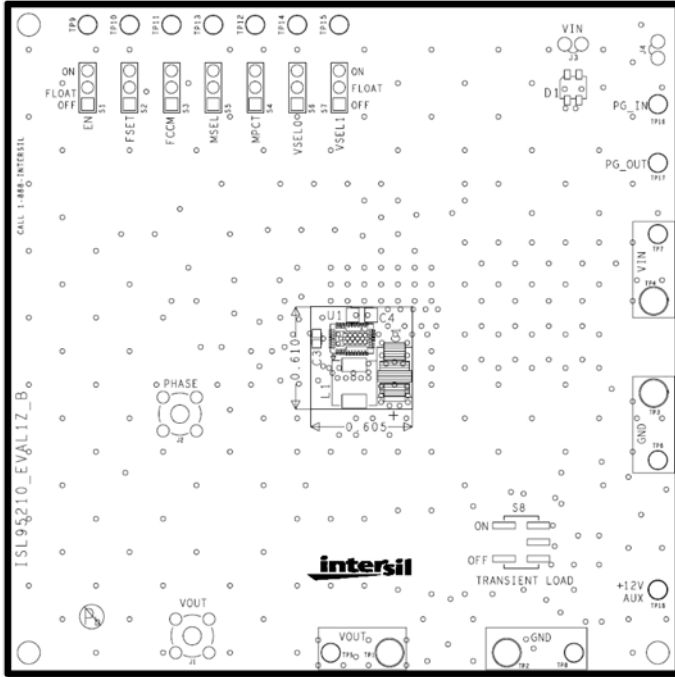

FIGURE 3. SILK SCREEN TOP

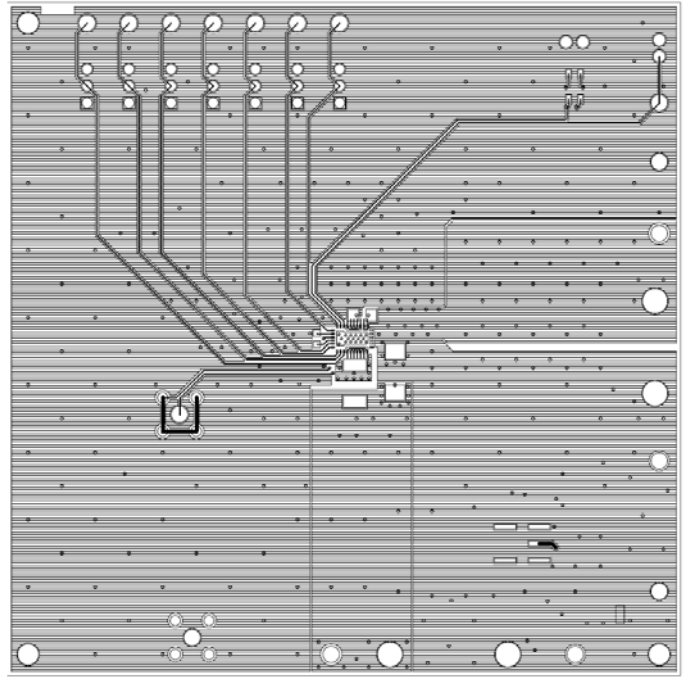

FIGURE 4. TOP LAYER

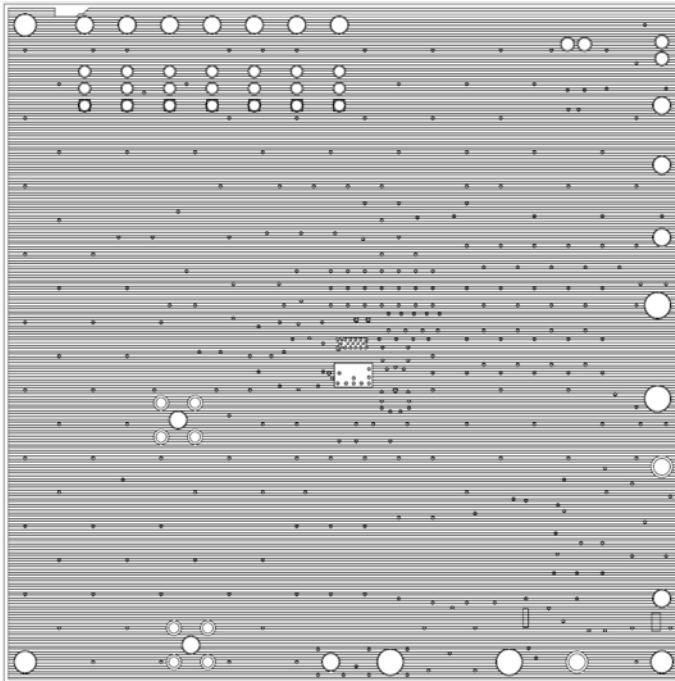

FIGURE 5. INTERNAL LAYER 1

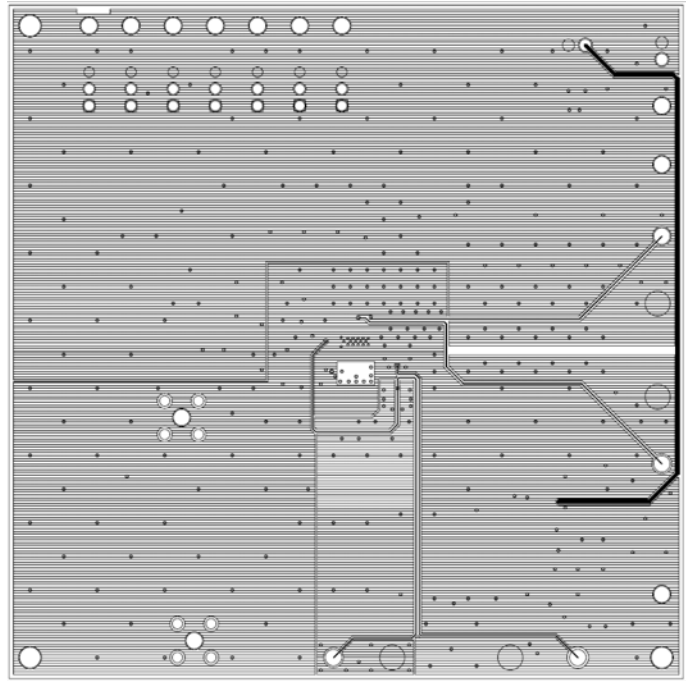

FIGURE 6. INTERNAL LAYER 2

# ISL95210EVAL1Z Layout (Continued)

Board consists of 4 layers of 2 ounce copper

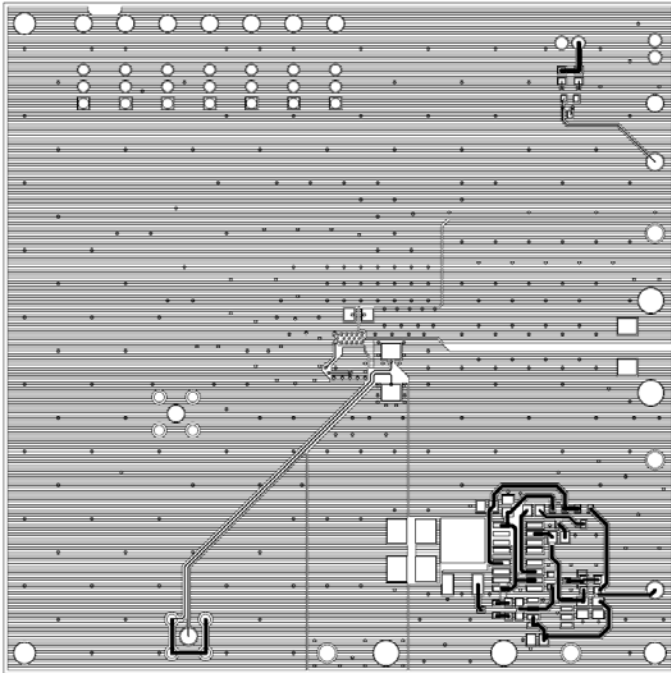

FIGURE 7. BOTTOM LAYER

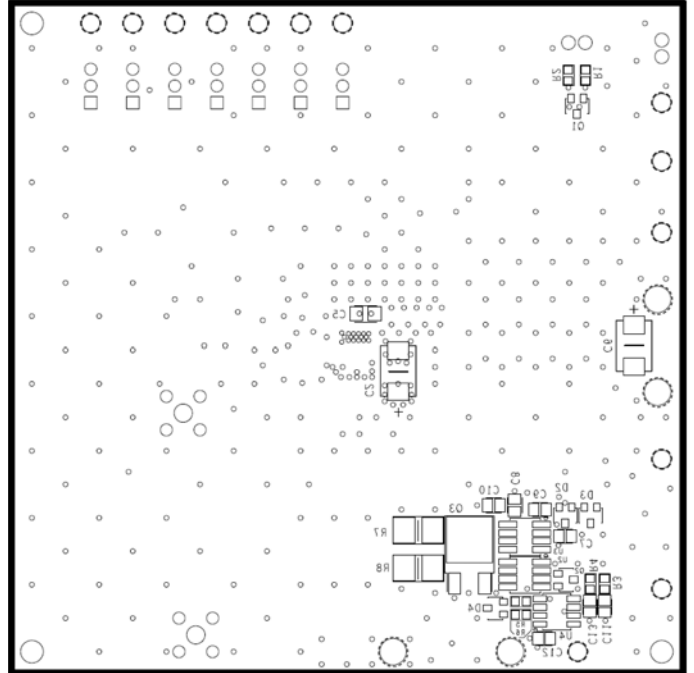

FIGURE 8. SILK SCREEN BOTTOM

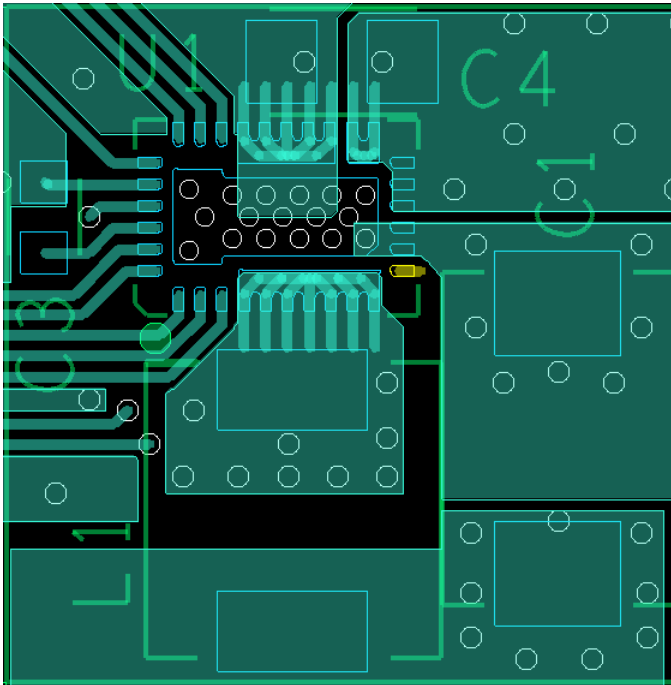

FIGURE 9. ZOOM OF APPLICATION ONLY (TOP LAYER)

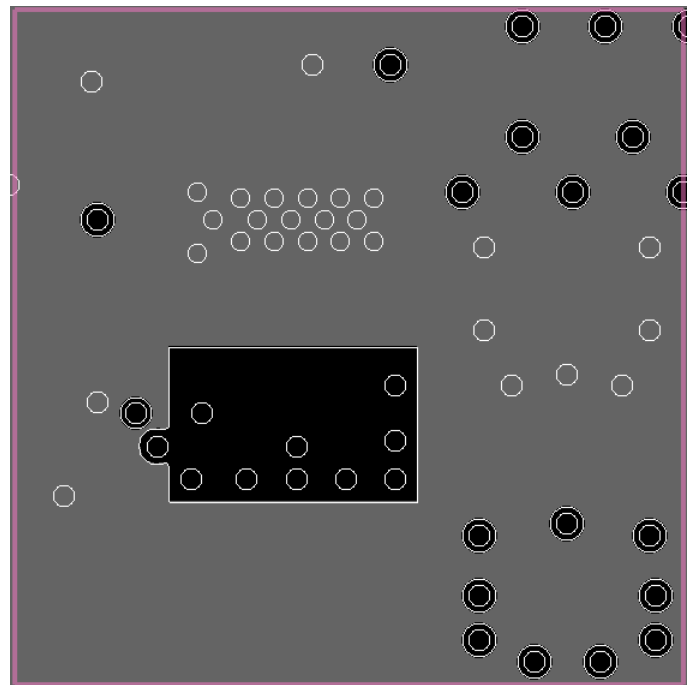

FIGURE 10. ZOOM OF APPLICATION ONLY (INTERNAL LAYER 1)

## ISL95210EVAL1Z Layout (Continued)

Board consists of 4 layers of 2 ounce copper

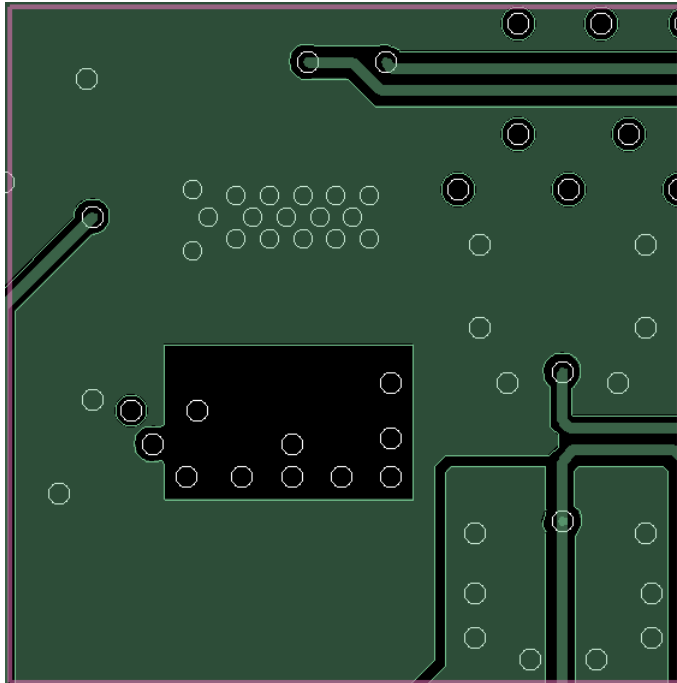

FIGURE 11. ZOOM OF APPLICATION ONLY (INTERNAL LAYER 2)

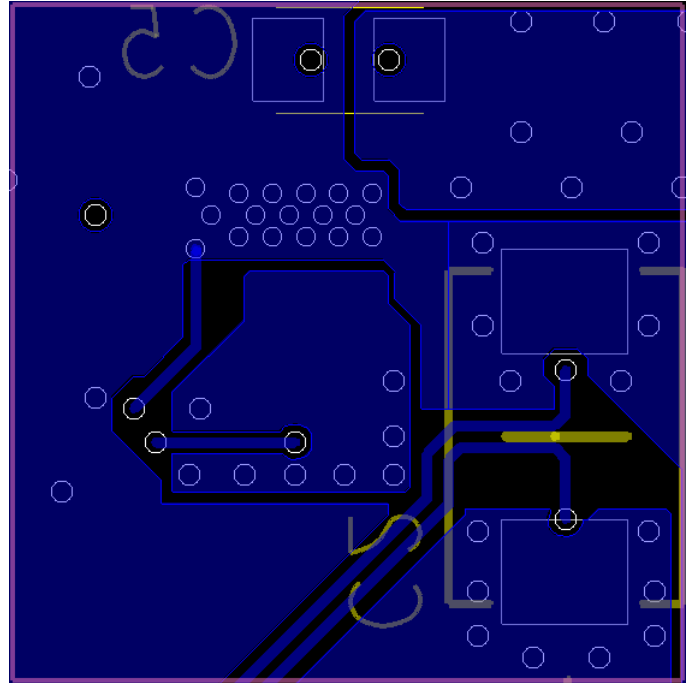

FIGURE 12. ZOOM OF APPLICATION ONLY (BOTTOM LAYER)

## Notice

1. Descriptions of circuits, software and other related information in this document are provided only to illustrate the operation of semiconductor products and application examples. You are fully responsible for the incorporation or any other use of the circuits, software, and information in the design of your product or system. Renesas Electronics disclaims any and all liability for any losses and damages incurred by you or third parties arising from the use of these circuits, software, or information.
2. Renesas Electronics hereby expressly disclaims any warranties against and liability for infringement or any other claims involving patents, copyrights, or other intellectual property rights of third parties, by or arising from the use of Renesas Electronics products or technical information described in this document, including but not limited to, the product data, drawings, charts, programs, algorithms, and application examples.
3. No license, express, implied or otherwise, is granted hereby under any patents, copyrights or other intellectual property rights of Renesas Electronics or others.
4. You shall not alter, modify, copy, or reverse engineer any Renesas Electronics product, whether in whole or in part. Renesas Electronics disclaims any and all liability for any losses or damages incurred by you or third parties arising from such alteration, modification, copying or reverse engineering.
5. Renesas Electronics products are classified according to the following two quality grades: "Standard" and "High Quality". The intended applications for each Renesas Electronics product depends on the product's quality grade, as indicated below.  
"Standard": Computers; office equipment; communications equipment; test and measurement equipment; audio and visual equipment; home electronic appliances; machine tools; personal electronic equipment; industrial robots; etc.  
"High Quality": Transportation equipment (automobiles, trains, ships, etc.); traffic control (traffic lights); large-scale communication equipment; key financial terminal systems; safety control equipment; etc.  
Unless expressly designated as a high reliability product or a product for harsh environments in a Renesas Electronics data sheet or other Renesas Electronics document, Renesas Electronics products are not intended or authorized for use in products or systems that may pose a direct threat to human life or bodily injury (artificial life support devices or systems; surgical implantations; etc.), or may cause serious property damage (space system; undersea repeaters; nuclear power control systems; aircraft control systems; key plant systems; military equipment; etc.). Renesas Electronics disclaims any and all liability for any damages or losses incurred by you or any third parties arising from the use of any Renesas Electronics product that is inconsistent with any Renesas Electronics data sheet, user's manual or other Renesas Electronics document.
6. When using Renesas Electronics products, refer to the latest product information (data sheets, user's manuals, application notes, "General Notes for Handling and Using Semiconductor Devices" in the reliability handbook, etc.), and ensure that usage conditions are within the ranges specified by Renesas Electronics with respect to maximum ratings, operating power supply voltage range, heat dissipation characteristics, installation, etc. Renesas Electronics disclaims any and all liability for any malfunctions, failure or accident arising out of the use of Renesas Electronics products outside of such specified ranges.
7. Although Renesas Electronics endeavors to improve the quality and reliability of Renesas Electronics products, semiconductor products have specific characteristics, such as the occurrence of failure at a certain rate and malfunctions under certain use conditions. Unless designated as a high reliability product or a product for harsh environments in a Renesas Electronics data sheet or other Renesas Electronics document, Renesas Electronics products are not subject to radiation resistance design. You are responsible for implementing safety measures to guard against the possibility of bodily injury, injury or damage caused by fire, and/or danger to the public in the event of a failure or malfunction of Renesas Electronics products, such as safety design for hardware and software, including but not limited to redundancy, fire control and malfunction prevention, appropriate treatment for aging degradation or any other appropriate measures. Because the evaluation of microcomputer software alone is very difficult and impractical, you are responsible for evaluating the safety of the final products or systems manufactured by you.
8. Please contact a Renesas Electronics sales office for details as to environmental matters such as the environmental compatibility of each Renesas Electronics product. You are responsible for carefully and sufficiently investigating applicable laws and regulations that regulate the inclusion or use of controlled substances, including without limitation, the EU RoHS Directive, and using Renesas Electronics products in compliance with all these applicable laws and regulations. Renesas Electronics disclaims any and all liability for damages or losses occurring as a result of your noncompliance with applicable laws and regulations.
9. Renesas Electronics products and technologies shall not be used for or incorporated into any products or systems whose manufacture, use, or sale is prohibited under any applicable domestic or foreign laws or regulations. You shall comply with any applicable export control laws and regulations promulgated and administered by the governments of any countries asserting jurisdiction over the parties or transactions.
10. It is the responsibility of the buyer or distributor of Renesas Electronics products, or any other party who distributes, disposes of, or otherwise sells or transfers the product to a third party, to notify such third party in advance of the contents and conditions set forth in this document.
11. This document shall not be reprinted, reproduced or duplicated in any form, in whole or in part, without prior written consent of Renesas Electronics.
12. Please contact a Renesas Electronics sales office if you have any questions regarding the information contained in this document or Renesas Electronics products.  
(Note 1) "Renesas Electronics" as used in this document means Renesas Electronics Corporation and also includes its directly or indirectly controlled subsidiaries.  
(Note 2) "Renesas Electronics product(s)" means any product developed or manufactured by or for Renesas Electronics.

(Rev.4.0-1 November 2017)



### SALES OFFICES

Renesas Electronics Corporation

<http://www.renesas.com>

Refer to "<http://www.renesas.com/>" for the latest and detailed information.

**Renesas Electronics America Inc.**  
1001 Murphy Ranch Road, Milpitas, CA 95035, U.S.A.  
Tel: +1-408-432-8888, Fax: +1-408-434-5351

**Renesas Electronics Canada Limited**  
9251 Yonge Street, Suite 8309 Richmond Hill, Ontario Canada L4C 9T3  
Tel: +1-905-237-2004

**Renesas Electronics Europe Limited**  
Dukes Meadow, Millboard Road, Bourne End, Buckinghamshire, SL8 5FH, U.K.  
Tel: +44-1628-651-700, Fax: +44-1628-651-804

**Renesas Electronics Europe GmbH**  
Arcadiastrasse 10, 40472 Düsseldorf, Germany  
Tel: +49-211-6503-0, Fax: +49-211-6503-1327

**Renesas Electronics (China) Co., Ltd.**  
Room 1709 Quantum Plaza, No.27 ZhichunLu, Haidian District, Beijing, 100191 P. R. China  
Tel: +86-10-8235-1155, Fax: +86-10-8235-7679

**Renesas Electronics (Shanghai) Co., Ltd.**  
Unit 301, Tower A, Central Towers, 555 Langao Road, Putuo District, Shanghai, 200333 P. R. China  
Tel: +86-21-2226-0888, Fax: +86-21-2226-0999

**Renesas Electronics Hong Kong Limited**  
Unit 1601-1611, 16/F., Tower 2, Grand Century Place, 193 Prince Edward Road West, Mongkok, Kowloon, Hong Kong  
Tel: +852-2265-6688, Fax: +852-2886-9022

**Renesas Electronics Taiwan Co., Ltd.**  
13F, No. 363, Fu Shing North Road, Taipei 10543, Taiwan  
Tel: +886-2-8175-9600, Fax: +886-2-8175-9670

**Renesas Electronics Singapore Pte. Ltd.**  
80 Bendemeer Road, Unit #06-02 Hyflux Innovation Centre, Singapore 339949  
Tel: +65-6213-0200, Fax: +65-6213-0300

**Renesas Electronics Malaysia Sdn.Bhd.**  
Unit 1207, Block B, Menara Amcorp, Amcorp Trade Centre, No. 18, Jln Persiaran Barat, 46050 Petaling Jaya, Selangor Darul Ehsan, Malaysia  
Tel: +60-3-7955-9390, Fax: +60-3-7955-9510

**Renesas Electronics India Pvt. Ltd.**  
No.777C, 100 Feet Road, HAL 2nd Stage, Indiranagar, Bangalore 560 038, India  
Tel: +91-80-67208700, Fax: +91-80-67208777

**Renesas Electronics Korea Co., Ltd.**  
17F, KAMCO Yangjae Tower, 262, Gangnam-daero, Gangnam-gu, Seoul, 06265 Korea  
Tel: +82-2-558-3737, Fax: +82-2-558-5338