

# μPC1251, μPC358

R03DS0116EJ0100  
Rev.1.00  
2017.12.25

## Single Power Supply Dual Operational Amplifiers

### DESCRIPTION

μPC1251, μPC358 are dual operational amplifiers designed to operate on a single power supply. The features include low-voltage operation, a common-mode input voltage that range from  $V^-$  (GND) level, an output from a  $V^-$  (GND) level that is determined by the output stage of class C push-pull circuit and a 50 μA(TYP.) constant current, and a low current consumption.

In addition to that, this amplifier can also operate in both positive and negative power supply and can be used extensively in various amplifier circuits.

The μPC1251 is suited for wide operating ambient temperature use due to its temperature expansion type, while μPC358 is for general purposes usage.

A DC parameter selection that is compatible to operational amplifiers is also available.

μPC451, μPC324 which are quad types with the same circuit configuration are also available under this series of operational amplifiers.

### FEATURES

- Input Offset Voltage  $\pm 2$  mV (TYP.)
- Input Offset Current  $\pm 5$  nA (TYP.)
- Large Signal Voltage Gain 100000 (TYP.)
- Internal Frequency Compensation
- Output Short-Circuit Protection

### Product Lineup

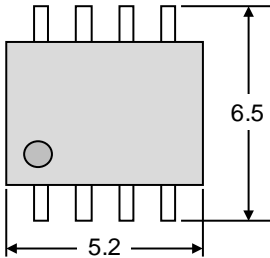
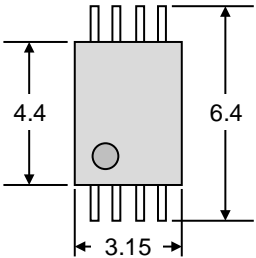
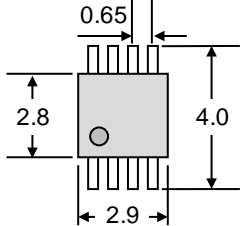
Package	Standard SOP	TSSOP	MSOP
Subject Part Number	μPC1251G2, μPC358G2	μPC1251GR-9LG, μPC358GR-9LG	μPC1251MP-KAA
Outline Comparison	Unit : mm 	Unit : mm 	Unit : mm 
(Mounting Area Ratio)	(100 %)	(60 %)	(34 %)

The information in this document is subject to change without notice. Before using this document, please confirm that this is the latest version. Not all products and/or types are available in every country. Please check with Renesas Electronics sales representative for availability and additional information.

### ORDERING INFORMATION

Part Number	Selected Grade	Package
μPC1251G2-A	Standard	8-pin plastic SOP ( 5.72 mm ( 225 ) )
μPC1251G2(5)-A	DC parameter selection	8-pin plastic SOP ( 5.72 mm ( 225 ) )
μPC358G2-A	Standard	8-pin plastic SOP ( 5.72 mm ( 225 ) )
μPC358G2(5)-A	DC parameter selection	8-pin plastic SOP ( 5.72 mm ( 225 ) )
μPC1251GR-9LG-A	Standard	8-pin plastic TSSOP ( 5.72 mm ( 225 ) )
μPC1251GR(5)-9LG-A	DC parameter selection	8-pin plastic TSSOP ( 5.72 mm ( 225 ) )
μPC1251MP-KAA-A	Standard	8-pin plastic MSOP ( 2.8 × 2.9 )
μPC1251MP(5)-KAA-A	DC parameter selection	8-pin plastic MSOP ( 2.8 × 2.9 )
μPC358GR-9LG-A	Standard	8-pin plastic TSSOP ( 5.72 mm ( 225 ) )
μPC358GR(5)-9LG-A	DC parameter selection	8-pin plastic TSSOP ( 5.72 mm ( 225 ) )

### EQUIVALENT CIRCUIT (1/2 Circuit)

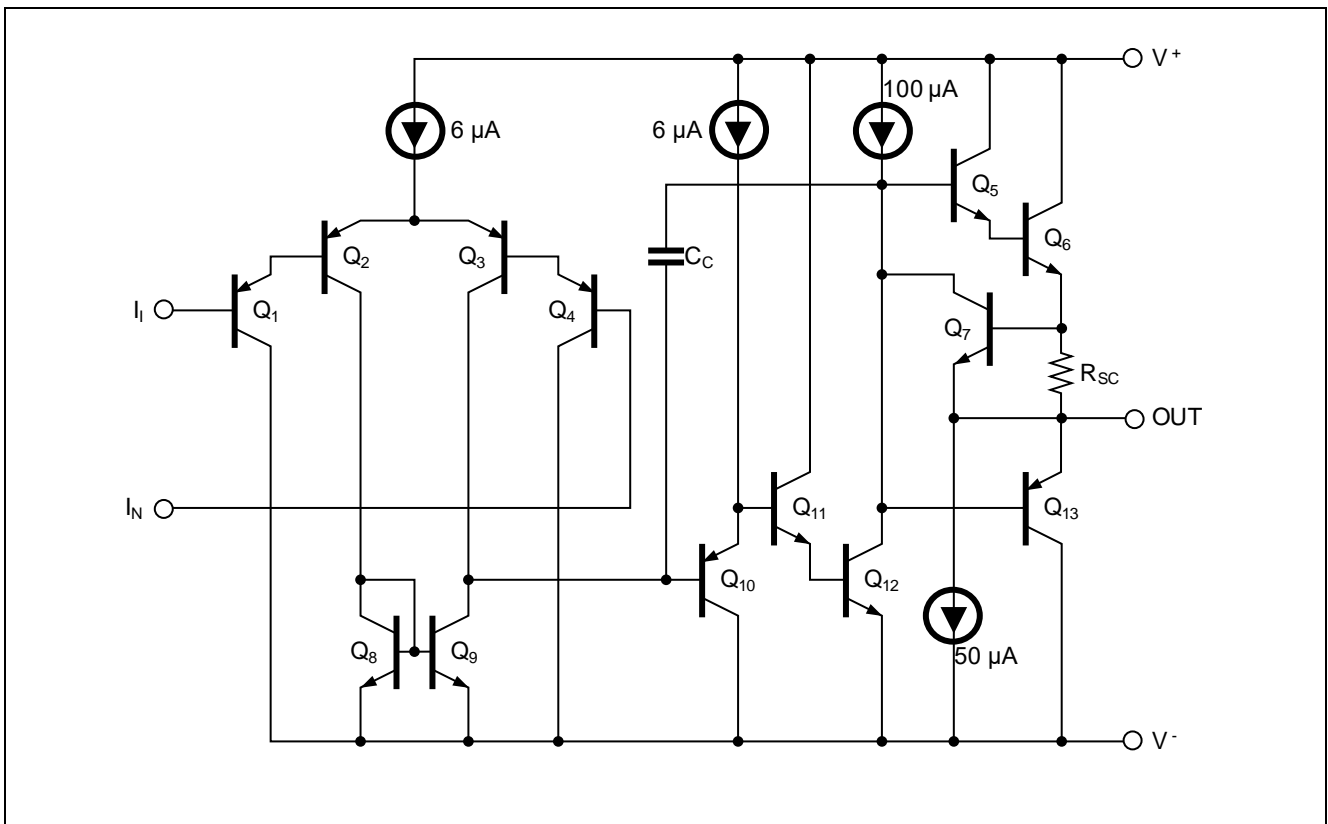

### PIN CONFIGURATION (Marking side)

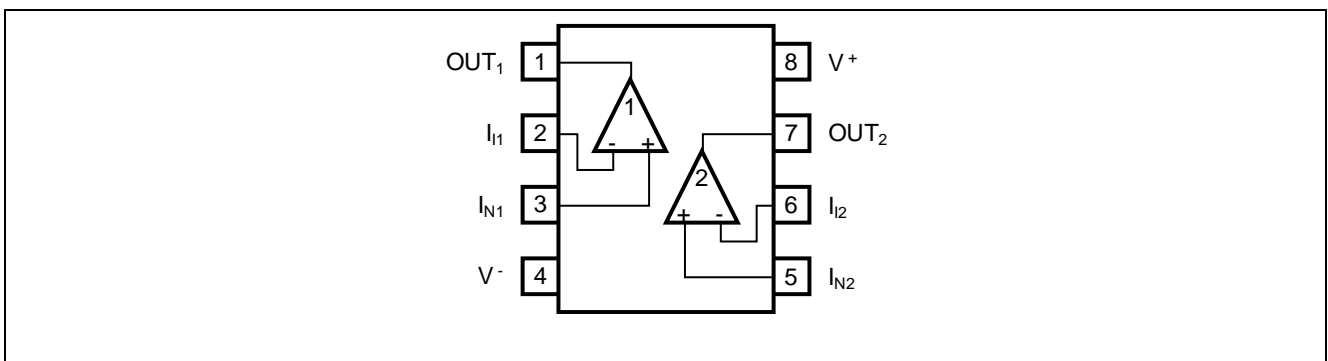

## ABSOLUTE MAXIMUM RATINGS

(T<sub>A</sub> = 25 °C)

Parameter	Symbol	μPC1251G2, μPC1251G2(5)	μPC358G2, μPC358G2(5)	μPC1251GR, μPC1251GR(5)	μPC1251MP, μPC1251MP(5)	μPC358GR, μPC358GR(5)	Unit	
Voltage between V+ and V- <small>Note1</small>	V <sup>+</sup> - V <sup>-</sup>	-0.3 ~ +32						V
Differential Input Voltage	V <sub>ID</sub>	±32						V
Input Voltage <small>Note2</small>	V <sub>I</sub>	V <sup>-</sup> -0.3 ~ V <sup>-</sup> +32						V
Output applied Voltage <small>Note3</small>	V <sub>o</sub>	V <sup>-</sup> -0.3 ~ V <sup>+</sup> +0.3						V
Total Power Dissipation <small>Note4</small>	P <sub>T</sub>	440						mW
Output Short Circuit Duration <small>Note5</small>	t <sub>s</sub>	Indefinite						s
Operating Ambient Temperature	T <sub>A</sub>	-40 ~ +85	-20 ~ +80	-40 ~ +125		-40 ~ +85	°C	
Storage Temperature	T <sub>stg</sub>	-55 ~ +125		-55 ~ +150		-55 ~ +125	°C	

- [Note]**
- Note that reverse connections of the power supply may damage the ICs.
  - The input voltage is allowed to input without damage or destruction independent of the magnitude of V+. Either input signal is not allowed to go negative by more than 0.3 V. In addition, the input voltage that operates normally as an operational amplifier is within the Common Mode Input Voltage range of an electrical characteristic.
  - A range where input voltage can be applied to an output pin externally with no deterioration or damage to the feature (characteristic). The input voltage can be applied regardless of the electric supply voltage. This specification which includes the transition state such as electric power ON/OFF must be kept.
  - This is the value when the glass epoxy substrate (size: 100 mm x 100 mm, thickness: 1 mm, 15% of the substrate area where only one side is copper foiled is filling wired) is mounted.  
Note that restrictions will be made to the following conditions for each product, and the derating ratio depending on the operating ambient temperature.

μPC1251G2 : Derate at -4.4 mW/°C when T<sub>A</sub> > 25 °C  
(Junction - ambient thermal resistance R<sub>th(J-A)</sub> = 227°C/W)

μPC358G2 : Derate at -4.4 mW/°C when T<sub>A</sub> > 25 °C  
(Junction - ambient thermal resistance R<sub>th(J-A)</sub> = 227°C/W)

μPC1251GR-9LG : Derate at -5.5 mW/°C when T<sub>A</sub> > 69 °C  
(Junction - ambient thermal resistance R<sub>th(J-A)</sub> = 183°C/W)

μPC1251MP-KAA : Derate at -4.8 mW/°C when T<sub>A</sub> > 58 °C  
(Junction - ambient thermal resistance R<sub>th(J-A)</sub> = 208°C/W)

μPC358GR-9LG : Derate at -5.5 mW/°C when T<sub>A</sub> > 44 °C  
(Junction - ambient thermal resistance R<sub>th(J-A)</sub> = 183°C/W)

- Short circuits from the output to V<sup>+</sup> can cause destruction. Pay careful attention to the total power dissipation by not exceeding the absolute maximum ratings, **Note 4**.

## RECOMMENDED OPERATING CONDITIONS

Parameter	Symbol	MIN.	TYP.	MAX.	Unit
Power Supply Voltage (Split)	V <sup>±</sup>	±1.5		±15	V
Power Supply Voltage (V <sup>-</sup> = GND)	V <sup>+</sup>	+3		+30	V

## ELECTRICAL CHARACTERISTICS

μPC1251, μPC358 (T<sub>A</sub> = 25 °C, V<sup>+</sup> = +5 V, V<sup>-</sup> = GND)

Parameter	Symbol	MIN.	TYP.	MAX.	Unit	Test Condition
Input Offset Voltage	V <sub>IO</sub>		±2	±7	mV	R <sub>S</sub> = 0 Ω
Input Offset Current	I <sub>IO</sub>		±5	±50	nA	
Input Bias Current <sup>Note 6</sup>	I <sub>B</sub>		14	250	nA	
Large Signal Voltage Gain	A <sub>V</sub>	25000	100000			R <sub>L</sub> ≥ 2 kΩ
Circuit Current <sup>Note 7</sup>	I <sub>CC</sub>		0.7	1.2	mA	R <sub>L</sub> = ∞, I <sub>O</sub> = 0 A
Common Mode Rejection Ratio	CMR	65	70		dB	
Supply Voltage Rejection Ratio	SVR	65	100		dB	
Output Voltage Swing	V <sub>O</sub>	0		V <sup>+</sup> -1.5	V	R <sub>L</sub> = 2 kΩ (Connected to GND)
Common Mode Input Voltage Range	V <sub>ICM</sub>	0		V <sup>+</sup> -1.5	V	
Output Source Current	I <sub>O SOURCE</sub>	20	40		mA	V <sub>IN(+)</sub> = +1 V, V <sub>IN(-)</sub> = 0 V
Output Sink Current	I <sub>O SINK1</sub>	10	20		mA	V <sub>IN(-)</sub> = +1 V, V <sub>IN(+)</sub> = 0 V
	I <sub>O SINK2</sub>	12	50		μA	V <sub>IN(-)</sub> = +1 V, V <sub>IN(+)</sub> = 0 V, V <sub>O</sub> = 200 mV
Channel Separation			120		dB	f = 1 ~ 20 kHz

μPC1251 (5), μPC358 (5) (T<sub>A</sub> = 25 °C, V<sup>+</sup> = +5 V, V<sup>-</sup> = GND)

Parameter	Symbol	MIN.	TYP.	MAX.	Unit	Test Condition
Input Offset Voltage	V <sub>IO</sub>		±2	±3	mV	R <sub>S</sub> = 0 Ω
Input Offset Current	I <sub>IO</sub>		±5	±50	nA	
Input Bias Current <sup>Note 6</sup>	I <sub>B</sub>		14	60	nA	
Large Signal Voltage Gain	A <sub>V</sub>	50000	100000			R <sub>L</sub> ≥ 2 kΩ
Circuit Current <sup>Note 7</sup>	I <sub>CC</sub>		0.7	0.9	mA	R <sub>L</sub> = ∞, I <sub>O</sub> = 0 A
Common Mode Rejection Ratio	CMR	65	70		dB	
Supply Voltage Rejection Ratio	SVR	65	100		dB	
Output Voltage Swing	V <sub>O</sub>	0		V <sup>+</sup> -1.5	V	R <sub>L</sub> = 2 kΩ (Connected to GND)
Common Mode Input Voltage Range	V <sub>ICM</sub>	0		V <sup>+</sup> -1.4	V	
Output Source Current	I <sub>O SOURCE</sub>	30	40		mA	V <sub>IN(+)</sub> = +1 V, V <sub>IN(-)</sub> = 0 V
Output Sink Current	I <sub>O SINK1</sub>	15	20		mA	V <sub>IN(-)</sub> = +1 V, V <sub>IN(+)</sub> = 0 V
	I <sub>O SINK2</sub>	30	50	70	μA	V <sub>IN(-)</sub> = +1 V, V <sub>IN(+)</sub> = 0 V, V <sub>O</sub> = 200 mV
Channel Separation			120		dB	f = 1 ~ 20 kHz

**[Note]** 6. The absolute value of the input bias current is small, thus the direction of the current flowing from the inside of the IC may be reversed due to variations in the product during high temperature.

7. This is a current that flows in the internal circuit. This current will flow irrespective of the channel used.

TYPICAL PERFORMANCE CHARACTERISTICS (T<sub>A</sub> = 25 °C, TYP.) (Reference Value)

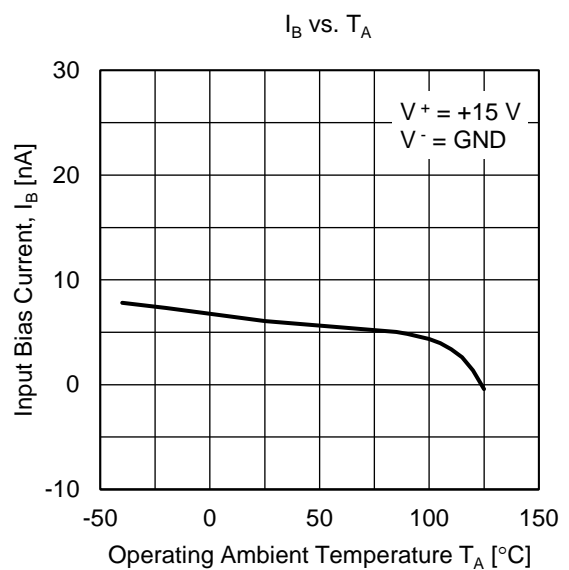
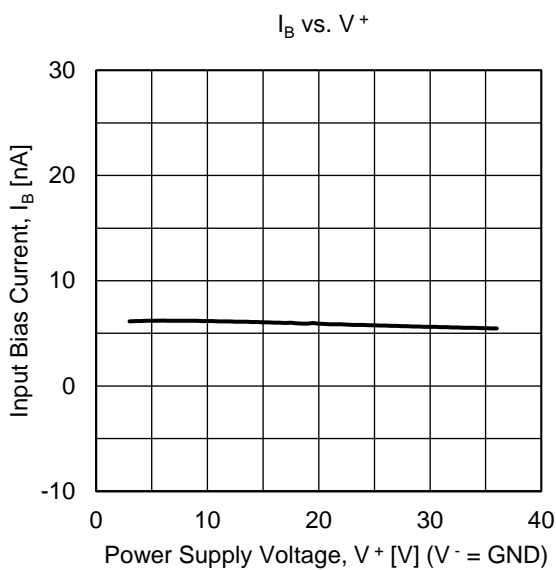
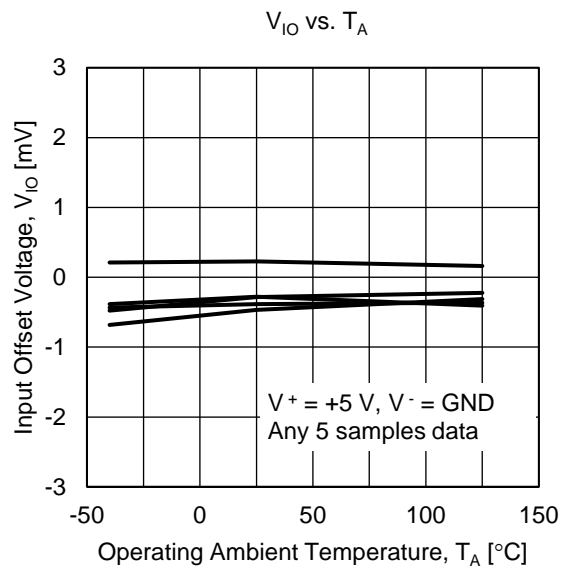
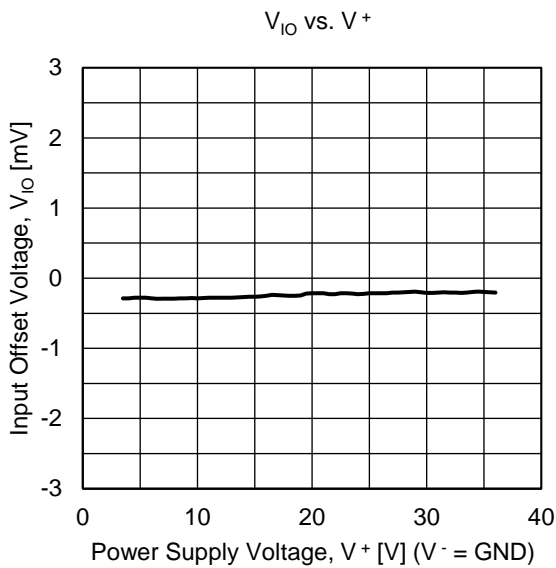
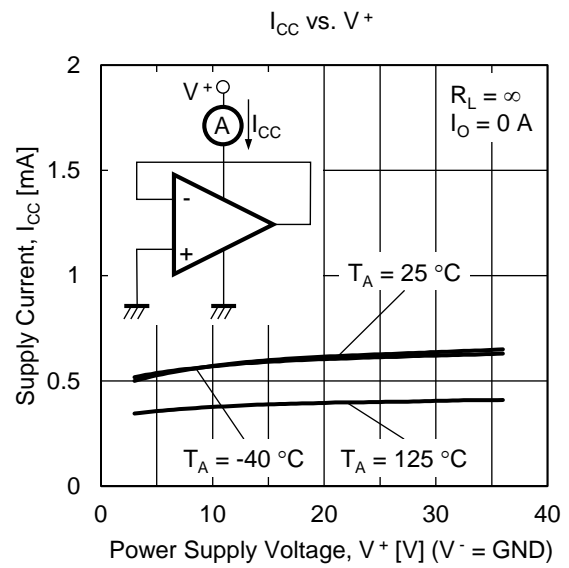
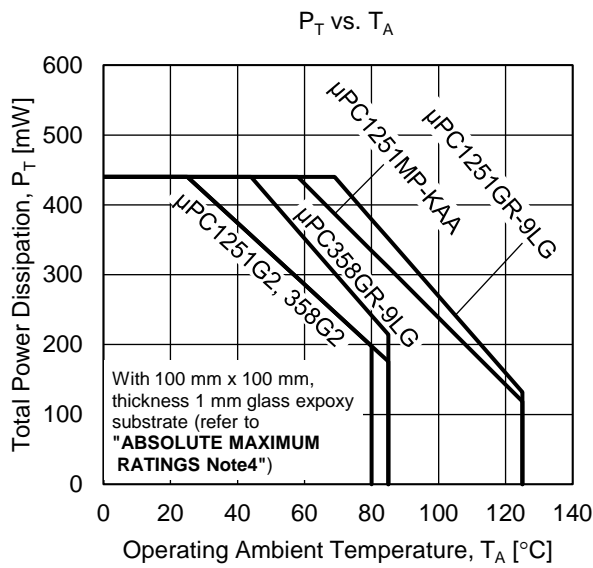

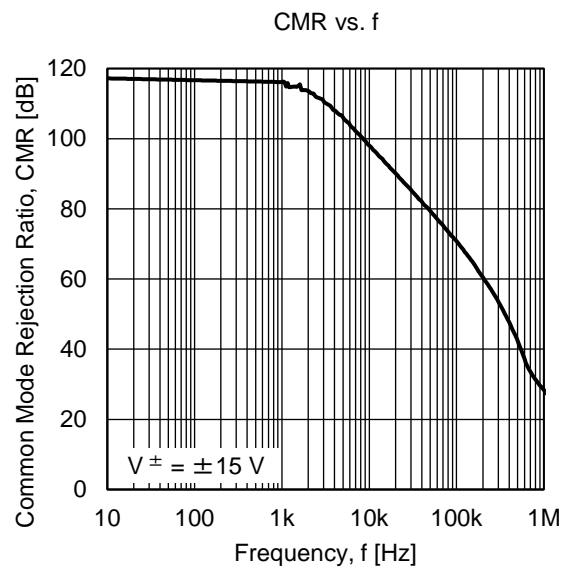
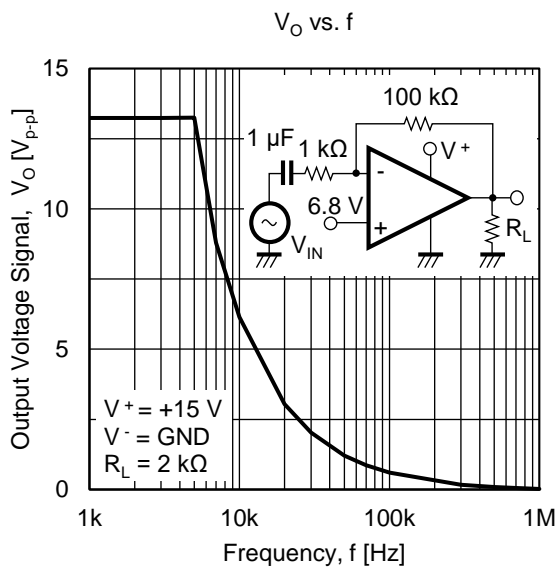
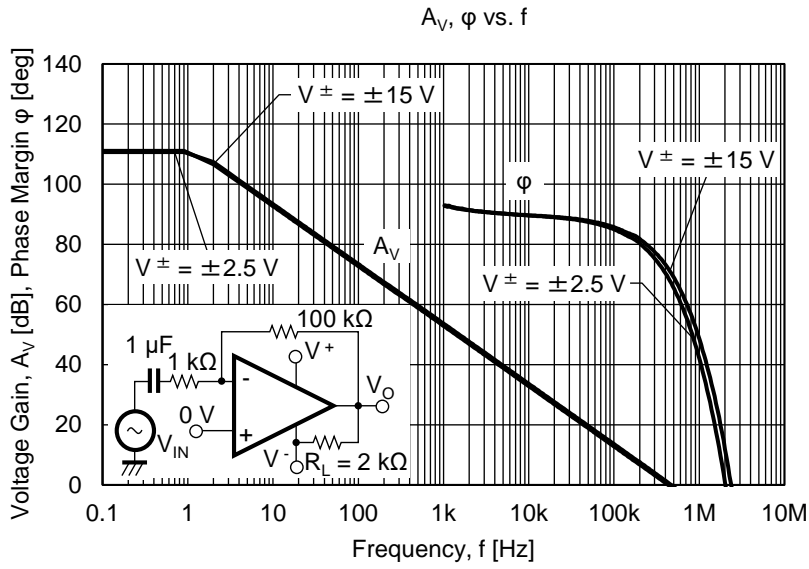
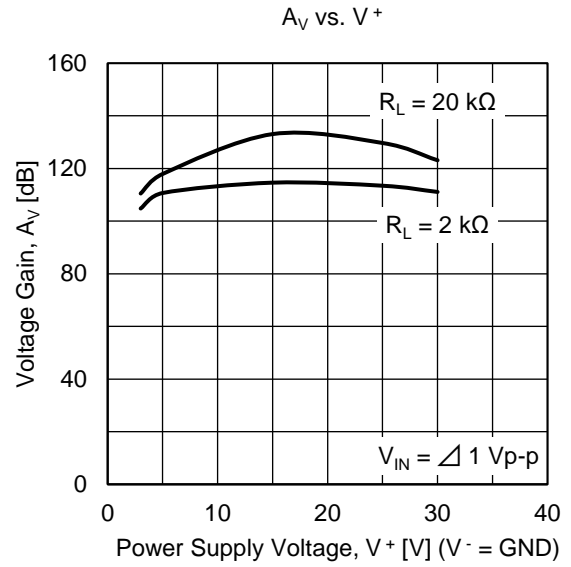
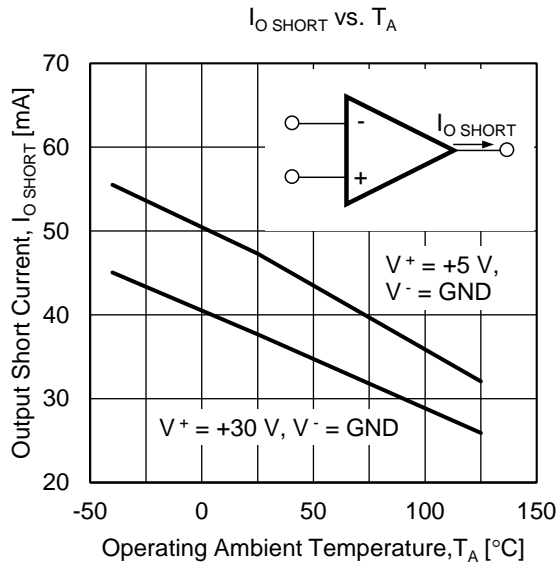

Pulse Response

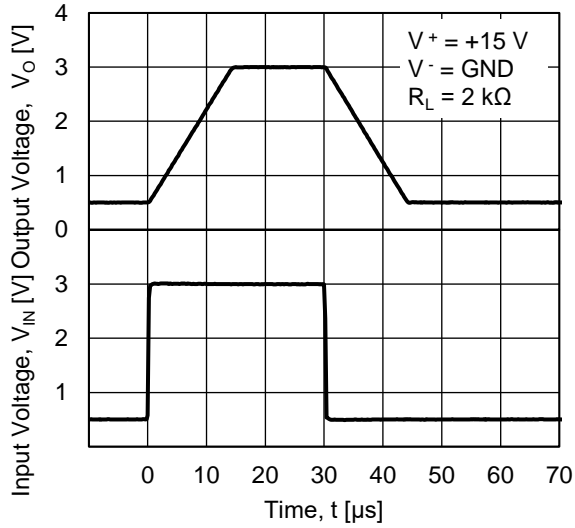

SR -  $T_A$

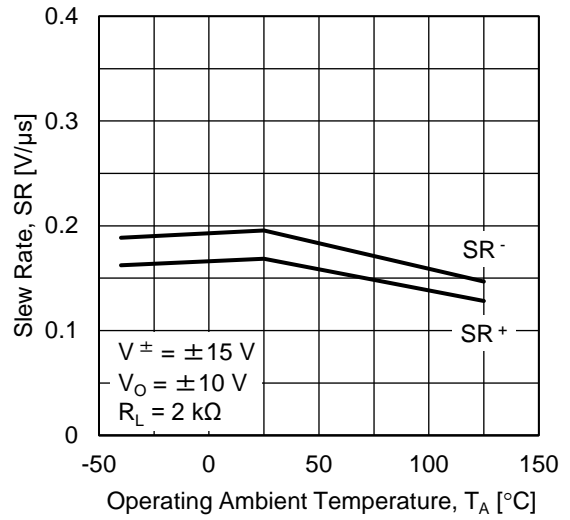

$V_O$  vs.  $I_{O \text{ SINK}}$

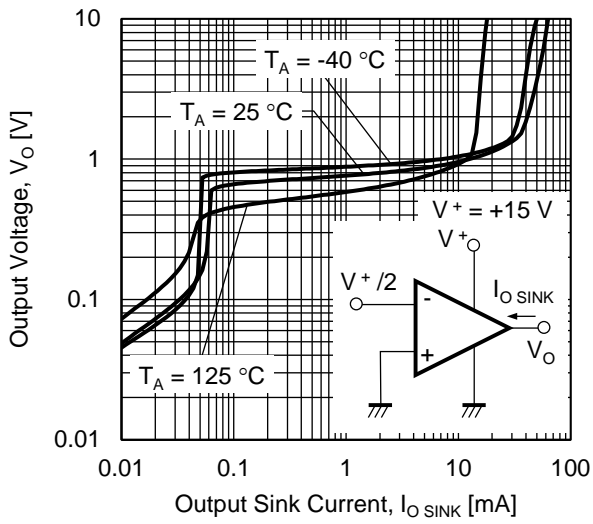

$\Delta V_O$  vs.  $I_{O \text{ SOURCE}}$

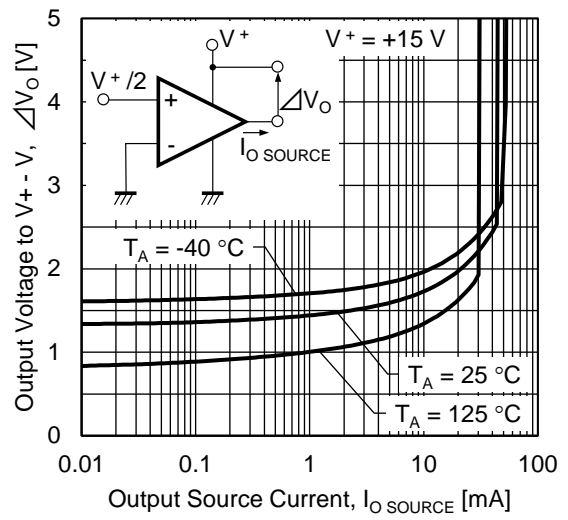

## USE WITH PRECAUTIONS

- **The process of unused circuits**

If there is an unused circuit, the following connection is recommended.

### Process example of unused circuits

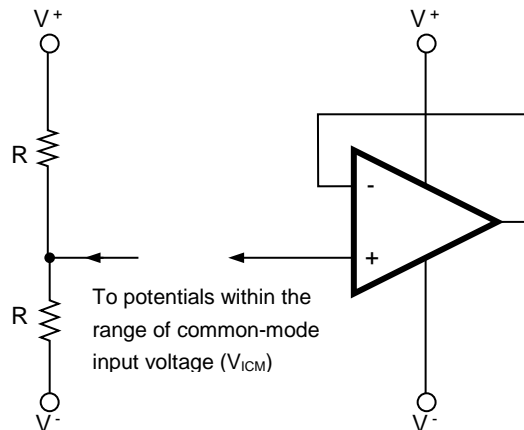

**Remark:** A midpoint potential of  $V^+$  and  $V^-$  is applied to this example.

- **Ratings of input/output pin voltage**

When the voltage of input/output pin exceeds the absolute maximum rating, it may cause degradation of characteristics or damage, by a conduction of a parasitic diode within an IC. In addition, if the input pin is lower than  $V^-$ , or the output pin exceeds the power supply voltage, it is recommended to make a clamp circuit using a diode with low forward voltage (e.g.: Schottky diode) as protection.

- **Range of common-mode input voltage**

When the supply voltage does not meet the condition of electrical characteristics, the range of common-mode input voltage is as follows.

$V_{ICM}$  (TYP.):  $V^-$  to  $V^+ - 1.5$  (V) ( $T_A = 25^\circ\text{C}$ ).

During designing, do include some tolerance by considering temperature characteristics and etc.

- **Maximum output voltage**

The TYP. value range of the maximum output voltage when the supply voltage does not meet the condition of electrical characteristics is as follows:

$V_{om+}$  (TYP.):  $V^+ - 1.5$  (V) ( $T_A = 25^\circ\text{C}$ ),  $V_{om-}$  (TYP.) ( $I_{O\ SINK} \leq 50\ \mu\text{A}$ ): Approx.  $V^-$  (V) ( $T_A = 25^\circ\text{C}$ ).

During designing, include some tolerance such as characteristics variation and temperature characteristics consideration and so forth. In addition, also note that the output voltage range ( $V_{om+} - V_{om-}$ ) will become narrow when an output current increases.

- **Operation of output**

This IC output level consist of a class C push-pull. Therefore, when a load resistance is connected to the midpoint potential of  $V^+$ ,  $V^-$ , a crossover distortion occurs during the transition state of output current flow direction (source, sink).

- **Handling of ICs**

When stress is added to the ICs due to warpage or bending of a board, the characteristic may fluctuates due to piezoelectric effect. Therefore, pay attention to warpage or bending of a board.



## PACKAGE DRAWINGS

### 8-PIN PLASTIC SOP

JEITA Package code	RENESAS code	Previous code	MASS (TYP.) [g]
P-SOP8-0225-1.27	PRSP0008DL-A	S8GM-50-225B	0.08

Unit: mm

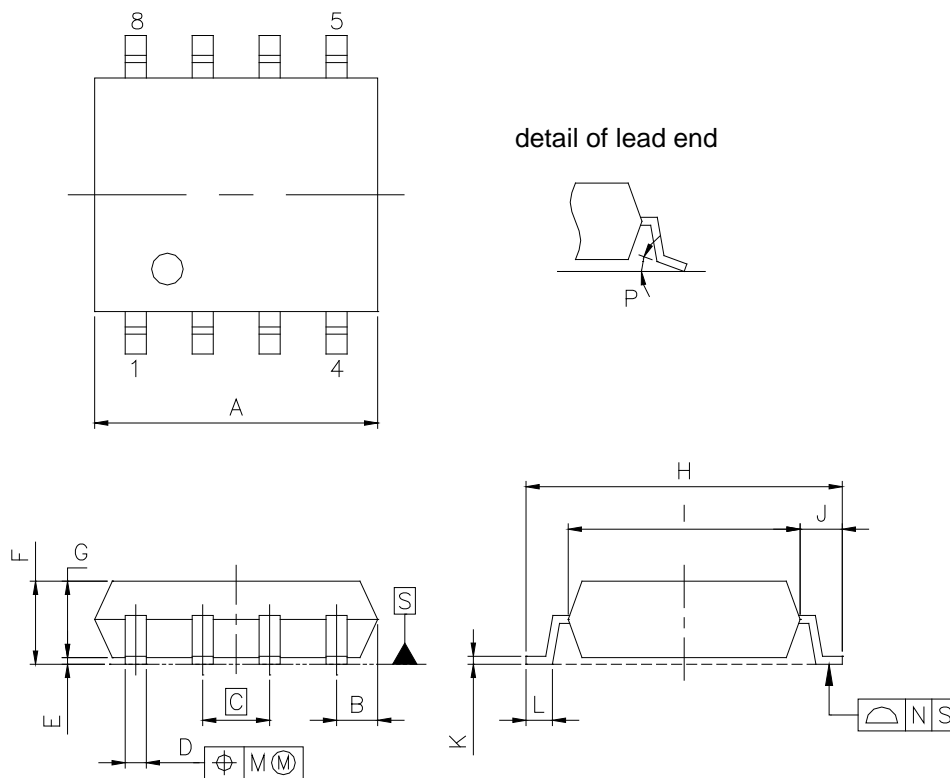

#### NOTE

Each lead centerline is located within 0.12 mm of its true position (T.P.) at maximum material condition.

ITEM	MILLIMETERS
A	5.2 <sup>+0.17</sup> / <sub>-0.20</sub>
B	0.78 MAX
<span style="border: 1px solid black; padding: 2px;">C</span>	1.27 (T.P)
D	0.42 <sup>+0.08</sup> / <sub>-0.07</sub>
E	0.1 ±0.1
F	1.59 ±0.21
G	1.49
H	6.5 ±0.3
I	4.4 ±0.15
J	1.1 ±0.2
K	0.17 <sup>+0.08</sup> / <sub>-0.07</sub>
L	0.6 ±0.2
M	0.12
N	0.10
P	3° <sup>+7°</sup> / <sub>-3°</sub>

8-PIN PLASTIC TSSOP

JEITA Package code	RENESAS code	Previous code	MASS(TYP.) [g]
P-TSSOP8-0225-0.65	PTSP0008JD-A	P8GR-65-9LG	—

Unit : mm

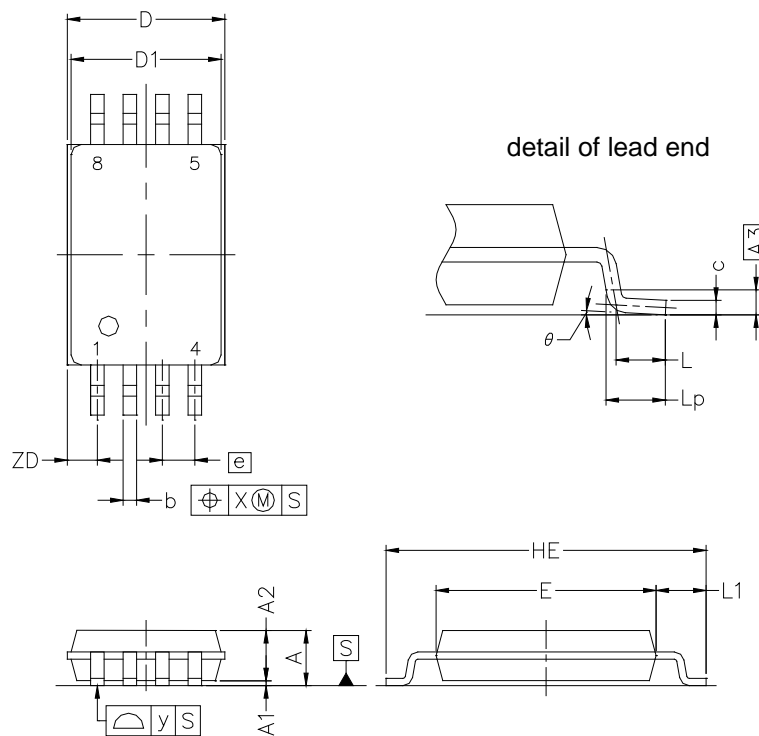

**NOTE**

Each lead centerline is located within 0.10 mm of its true position at maximum material condition.

ITEM	MILLIMETERS
D	3.15 ±0.15
D1	3.00 ±0.10
E	4.40 ±0.10
HE	6.40 ±0.20
A	1.20 MAX.
A1	0.10 ±0.05
A2	1.00 ±0.05
A3	0.25
b	0.24 <sup>+0.06</sup> / <sub>-0.05</sub>
c	0.145 ±0.055
L	0.5
Lp	0.60 ±0.15
L1	1.00 ±0.20
θ	3° <sup>+5°</sup> / <sub>-3°</sub>
e	0.65
x	0.10
y	0.10
ZD	0.60

8-PIN PLASTIC MSOP

JEITA Package Code	RENESAS Code	Previous Code	MASS (TYP.) [g]
P-TSSOP8-2.8x2.9-0.65	PTSP0008JF-A	P8MP-65-KAA-1	0.02

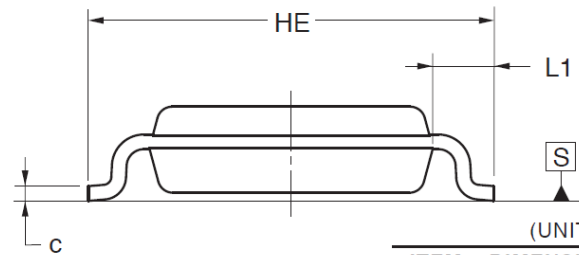
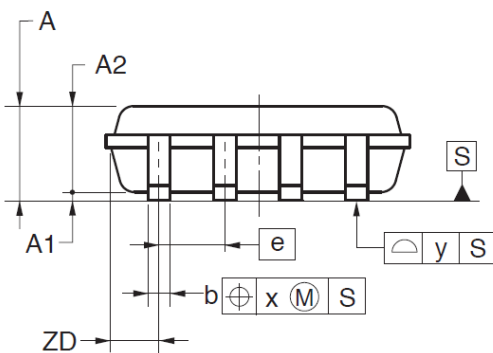
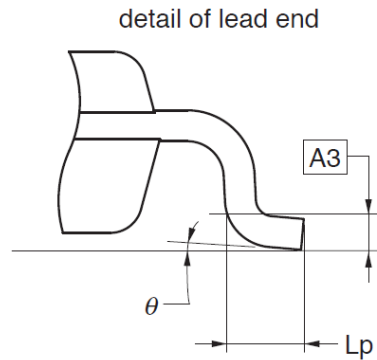
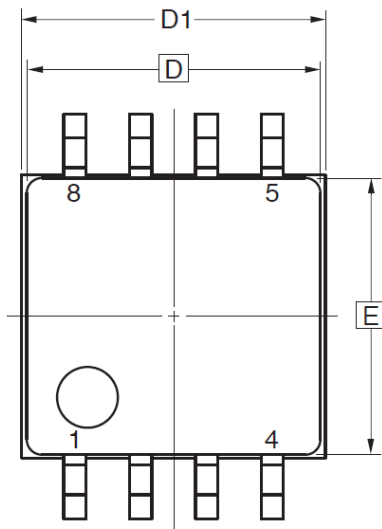

(UNIT:mm)

ITEM	DIMENSIONS
D	2.90
D1	3.00±0.20
E	2.80
HE	4.00±0.20
e	0.65
b	0.22±0.05
A	1.03 MAX.
A1	0.08±0.05
A2	0.85±0.05
A3	0.25
L1	0.60±0.20
c	0.145 <sup>+0.05</sup> <sub>-0.03</sub>
Lp	0.37±0.10
x	0.10
y	0.10
θ	3° <sup>+5°</sup> <sub>-3°</sub>
ZD	0.525

**NOTE**

Each lead centerline is located within 0.10 mm of its true position at maximum material condition.

## Notice

1. Descriptions of circuits, software and other related information in this document are provided only to illustrate the operation of semiconductor products and application examples. You are fully responsible for the incorporation or any other use of the circuits, software, and information in the design of your product or system. Renesas Electronics disclaims any and all liability for any losses and damages incurred by you or third parties arising from the use of these circuits, software, or information.
2. Renesas Electronics hereby expressly disclaims any warranties against liability for infringement or any other claims involving patents, copyrights, or other intellectual property rights of third parties, by or arising from the use of Renesas Electronics products or technical information described in this document, including but not limited to, the product data, drawings, charts, programs, algorithms, and application examples.
3. No license, express, implied or otherwise, is granted hereby under any patents, copyrights or other intellectual property rights of Renesas Electronics or others.
4. You shall not alter, modify, copy, or reverse engineer any Renesas Electronics product, whether in whole or in part. Renesas Electronics disclaims any and all liability for any losses or damages incurred by you or third parties arising from such alteration, modification, copying or reverse engineering.
5. Renesas Electronics products are classified according to the following two quality grades: "Standard" and "High Quality". The intended applications for each Renesas Electronics product depends on the product's quality grade, as indicated below.  
"Standard": Computers; office equipment; communications equipment; test and measurement equipment; audio and visual equipment; home electronic appliances; machine tools; personal electronic equipment; industrial robots; etc.  
"High Quality": Transportation equipment (automobiles, trains, ships, etc.); traffic control (traffic lights); large-scale communication equipment; key financial terminal systems; safety control equipment; etc.  
Unless expressly designated as a high reliability product or a product for harsh environments in a Renesas Electronics data sheet or other Renesas Electronics document, Renesas Electronics products are not intended or authorized for use in products or systems that may pose a direct threat to human life or bodily injury (artificial life support devices or systems; surgical implantations; etc.), or may cause serious property damage (space system; undersea repeaters; nuclear power control systems; aircraft control systems; key plant systems; military equipment; etc.). Renesas Electronics disclaims any and all liability for any damages or losses incurred by you or any third parties arising from the use of any Renesas Electronics product that is inconsistent with any Renesas Electronics data sheet, user's manual or other Renesas Electronics document.
6. When using Renesas Electronics products, refer to the latest product information (data sheets, user's manuals, application notes, "General Notes for Handling and Using Semiconductor Devices" in the reliability handbook, etc.), and ensure that usage conditions are within the ranges specified by Renesas Electronics with respect to maximum ratings, operating power supply voltage range, heat dissipation characteristics, installation, etc. Renesas Electronics disclaims any and all liability for any malfunctions, failure or accident arising out of the use of Renesas Electronics products outside of such specified ranges.
7. Although Renesas Electronics endeavors to improve the quality and reliability of Renesas Electronics products, semiconductor products have specific characteristics, such as the occurrence of failure at a certain rate and malfunctions under certain use conditions. Unless designated as a high reliability product or a product for harsh environments in a Renesas Electronics data sheet or other Renesas Electronics document, Renesas Electronics products are not subject to radiation resistance design. You are responsible for implementing safety measures to guard against the possibility of bodily injury, injury or damage caused by fire, and/or danger to the public in the event of a failure or malfunction of Renesas Electronics products, such as safety design for hardware and software, including but not limited to redundancy, fire control and malfunction prevention, appropriate treatment for aging degradation or any other appropriate measures. Because the evaluation of microcomputer software alone is very difficult and impractical, you are responsible for evaluating the safety of the final products or systems manufactured by you.
8. Please contact a Renesas Electronics sales office for details as to environmental matters such as the environmental compatibility of each Renesas Electronics product. You are responsible for carefully and sufficiently investigating applicable laws and regulations that regulate the inclusion or use of controlled substances, including without limitation, the EU RoHS Directive, and using Renesas Electronics products in compliance with all these applicable laws and regulations. Renesas Electronics disclaims any and all liability for damages or losses occurring as a result of your noncompliance with applicable laws and regulations.
9. Renesas Electronics products and technologies shall not be used for or incorporated into any products or systems whose manufacture, use, or sale is prohibited under any applicable domestic or foreign laws or regulations. You shall comply with any applicable export control laws and regulations promulgated and administered by the governments of any countries asserting jurisdiction over the parties or transactions.
10. It is the responsibility of the buyer or distributor of Renesas Electronics products, or any other party who distributes, disposes of, or otherwise sells or transfers the product to a third party, to notify such third party in advance of the contents and conditions set forth in this document.
11. This document shall not be reprinted, reproduced or duplicated in any form, in whole or in part, without prior written consent of Renesas Electronics.
12. Please contact a Renesas Electronics sales office if you have any questions regarding the information contained in this document or Renesas Electronics products.  
(Note 1) "Renesas Electronics" as used in this document means Renesas Electronics Corporation and also includes its directly or indirectly controlled subsidiaries.  
(Note 2) "Renesas Electronics product(s)" means any product developed or manufactured by or for Renesas Electronics.

(Rev.4.0-1 November 2017)



### SALES OFFICES

Renesas Electronics Corporation

<http://www.renesas.com>

Refer to "<http://www.renesas.com/>" for the latest and detailed information.

#### Renesas Electronics America Inc.

1001 Murphy Ranch Road, Milpitas, CA 95035, U.S.A.  
Tel: +1-408-432-8888, Fax: +1-408-434-5351

#### Renesas Electronics Canada Limited

9251 Yonge Street, Suite 8309 Richmond Hill, Ontario Canada L4C 9T3  
Tel: +1-905-237-2004

#### Renesas Electronics Europe Limited

Dukes Meadow, Millboard Road, Bourne End, Buckinghamshire, SL8 5FH, U.K  
Tel: +44-1628-651-700, Fax: +44-1628-651-804

#### Renesas Electronics Europe GmbH

Arcadiastrasse 10, 40472 Düsseldorf, Germany  
Tel: +49-211-6503-0, Fax: +49-211-6503-1327

#### Renesas Electronics (China) Co., Ltd.

Room 1709 Quantum Plaza, No.27 ZhichunLu, Haidian District, Beijing, 100191 P. R. China  
Tel: +86-10-8235-1155, Fax: +86-10-8235-7679

#### Renesas Electronics (Shanghai) Co., Ltd.

Unit 301, Tower A, Central Towers, 555 Langao Road, Putuo District, Shanghai, 200333 P. R. China  
Tel: +86-21-2226-0888, Fax: +86-21-2226-0999

#### Renesas Electronics Hong Kong Limited

Unit 1601-1611, 16/F., Tower 2, Grand Century Place, 193 Prince Edward Road West, Mongkok, Kowloon, Hong Kong  
Tel: +852-2265-6688, Fax: +852 2886-9022

#### Renesas Electronics Taiwan Co., Ltd.

13F, No. 363, Fu Shing North Road, Taipei 10543, Taiwan  
Tel: +886-2-8175-9600, Fax: +886 2-8175-9670

#### Renesas Electronics Singapore Pte. Ltd.

80 Bendemeer Road, Unit #06-02 Hyflux Innovation Centre, Singapore 339949  
Tel: +65-6213-0200, Fax: +65-6213-0300

#### Renesas Electronics Malaysia Sdn.Bhd.

Unit 1207, Block B, Menara Amcorp, Amcorp Trade Centre, No. 18, Jln Persiaran Barat, 46050 Petaling Jaya, Selangor Darul Ehsan, Malaysia  
Tel: +60-3-7955-9390, Fax: +60-3-7955-9510

#### Renesas Electronics India Pvt. Ltd.

No.777C, 100 Feet Road, HAL 2nd Stage, Indiranagar, Bangalore 560 038, India  
Tel: +91-80-67208700, Fax: +91-80-67208777

#### Renesas Electronics Korea Co., Ltd.

17F, KAMCO Yangjae Tower, 262, Gangnam-daero, Gangnam-gu, Seoul, 06265 Korea  
Tel: +82-2-558-3737, Fax: +82-2-558-5338