

SLG47105

Smart Brightness-Controlled Lamp with Motion Sensor

This application note describes how to create a smart lamp with brightness intensity control and motion sensor using HVPAK.

The application note comes complete with design files which can be found in the Reference section.

Contents

1. **Terms and Definitions** 2

2. **References**..... 2

3. **Introduction** 3

4. **Construction and Operating Principle**..... 3

 4.1 Block Diagram 3

 4.2 Mode Select..... 3

 4.3 Night Mode 4

 4.4 Intensity-Controlled Mode..... 5

 4.5 LED Driver 5

 4.6 Motion Sensor..... 6

 4.7 Battery Discharge Notification 6

5. **Device Testing** 7

6. **Conclusion** 10

7. **Revision History** 11

Figures

Figure 1 Block Diagram 3

Figure 2 Mode Select Switch Design..... 3

Figure 3 Mode Select..... 4

Figure 4 Night Mode 4

Figure 5 Intensity-Controlled Mode 5

Figure 6 HV OUT Control 5

Figure 7 Motion Sensor 6

Figure 8 Oscillators Configuration 6

Figure 9 Battery Discharge Notification 7

Figure 10 Full Circuit Design 7

Figure 11 Period of the Schmitt Trigger Oscillator – 12.2 us..... 8

Figure 12 Period of the Schmitt Trigger Oscillator – 16.9 us..... 8

Figure 13 Period of the Schmitt Trigger Oscillator – 20.65 us..... 9

Figure 14 Period of the Schmitt Trigger Oscillator – 29.45 us..... 9

Figure 15 Period of the Schmitt Trigger Oscillator – 55.9 us..... 10

1. Terms and Definitions

AC	Alternating current
CMP	Comparator
CNT/DLY	Counter / Delay
DC	Direct current
DFF	D Flip-Flop
GPO	General purpose output
HV	High voltage
LUT	Look-Up Table
OSC	Oscillator
PWM	Pulse width modulation

2. References

For related documents and software, please visit:

<https://www.renesas.com/eu/en/products/programmable-mixed-signal-asic-ip-products/greenpak-programmable-mixed-signal-products/greenpak-high-voltage-programmable-mixed-signal-matrix>

Download our free GreenPAK Designer software [1] to open the .gp files [2] and view the proposed circuit design. Use the GreenPAK development tools [3] to freeze the design into your own customized IC in a matter of minutes. Renesas provides a complete library of application notes [4] featuring design examples as well as explanations of features and blocks within the Renesas IC.

[1] GreenPAK Designer Software, Software Download, and User Guide

[2] [AN-CM-340 Brightness Intensity Controlled Lamp with Motion Sensor.gp](#), GreenPAK Design File

[3] GreenPAK Development Tools, GreenPAK Development Tools Webpage

[4] GreenPAK Application Notes, GreenPAK Application Notes Webpage

[5] SLG47105 Datasheet

3. Introduction

The main goal of this application is to design a smart brightness-controlled lamp with a motion sensor using the SLG47105V. The system is designed using the HV macrocells and other internal and external components within the GreenPAK to interact with a motion sensor.

The lamp has two modes: the intensity-controlled and the night mode. In the intensity-controlled mode, the light becomes brighter when the ambient light decreases and vice versa. In the night mode, the brightness is constantly dimm. The light turns on only when the motion is detected by the PIR motion sensor. The lamp is powered with 3 AAA batteries (summary 4.5 V) and it has a red LED blinking signal to notify about batteries discharging.

The design can be used as additional lighting in the closet, in the hallway, in the garage, and so on.

4. Construction and Operating Principle

4.1 Block Diagram

The Block Diagram is shown in [Figure 1](#).

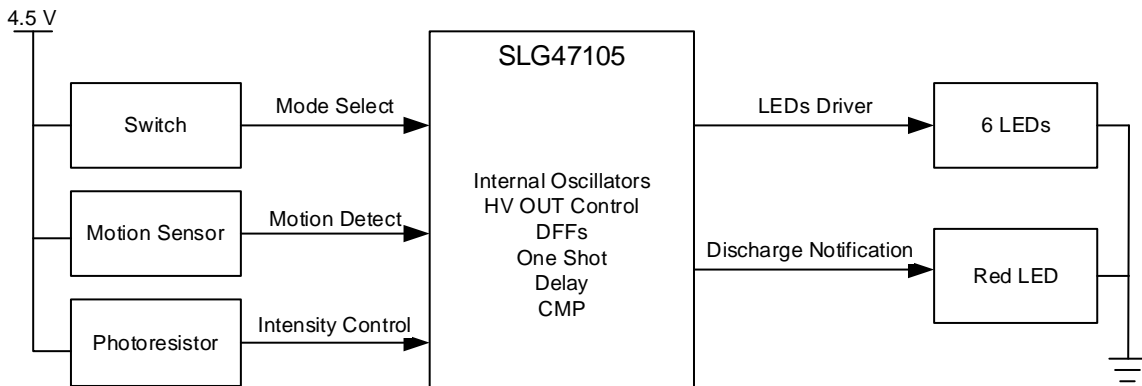

Figure 1 Block Diagram

4.2 Mode Select

The design consists of six main parts.

The first one is Mode Select Switch. The part of the GreenPAK design is shown in [Figure 2](#).

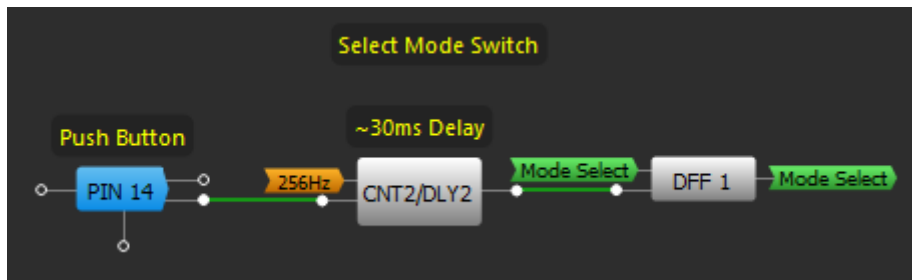

Figure 2 Mode Select Switch Design

The Mode Select Switch is LOW until pressing the button. Then the signal goes to DFF1, where the signal is latched before the next pressing. So, Mode Select has two states: LOW and HIGH, which are changed by pressing the button.

Then, the Mode Select signal goes to Mode Select part. The part of the GreenPAK design is shown in [Figure 3](#).

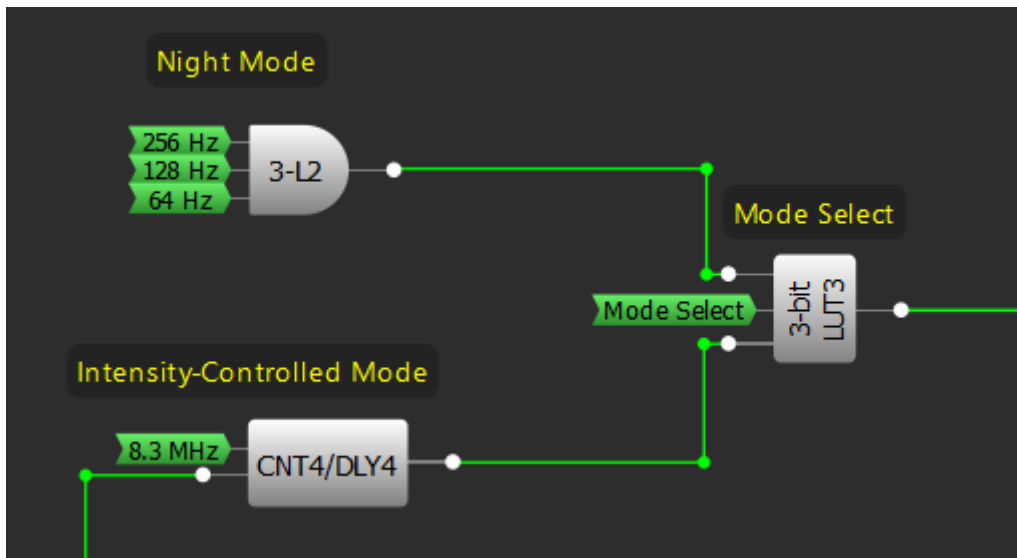

Figure 3 Mode Select

When the Mode Select is Low, the Output of LUT3 is the Output of Intensity-Controlled Mode, when the Mode Select is High, the Output of LUT3 is the Output of Night Mode.

4.3 Night Mode

The Night Mode is a stable PWM signal with the Duty Cycle of ~12.5 % and 64 Hz frequency (Figure 4).

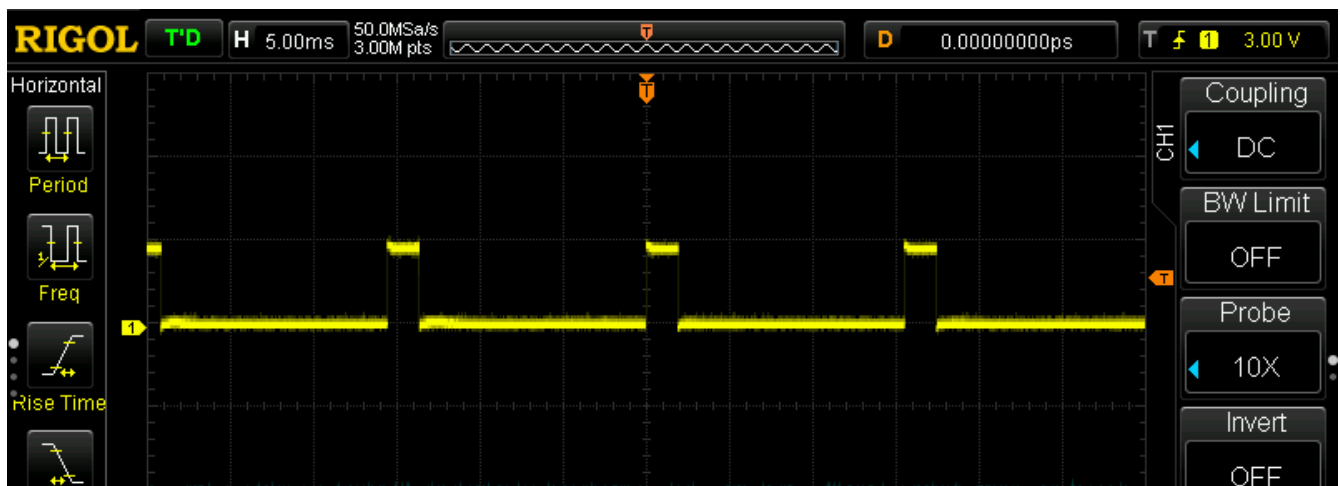

Figure 4 Night Mode

4.4 Intensity-Controlled Mode

The design of the Intensity-Controlled Mode is shown in Figure 5.

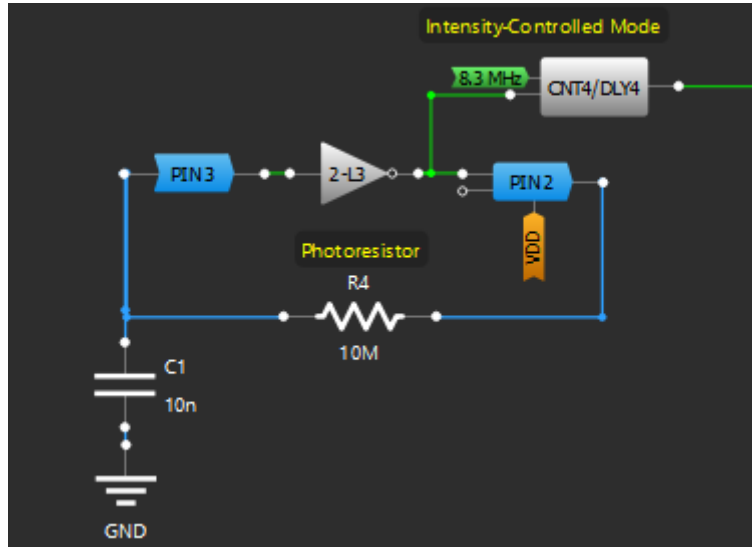

Figure 5 Intensity-Controlled Mode

The idea is to create a Schmitt Trigger Oscillator using PIN 2, PIN 3, Inverter, and a Resistor. In this case, the 10 M (dark resistance) photoresistor is used instead. It means that the frequency of the Oscillator depends on the value of the resistance. When the ambient light increases, the resistance decreases, and when it becomes darker, the resistance increases. Accordingly, when the resistance increases - the frequency decreases, and vice versa.

Then, this signal is used as data for the One-Shot macrocell (CNT4).

Since the clock – 8.3 MHz and the inverted One-Shot Pulse Width – 10.9 us are constant, the output signal results in PWM with a constant 10.9 us of LOW and the rest period of HIGH depending on the frequency generated by the Schmitt Trigger Oscillator with a photoresistor.

4.5 LED Driver

When the Mode is selected, the LUT3 output signal goes to HV OUT CTRL to drive the 6 LEDs connected in parallel. It is configured as Half-Bridge in Pre-Driver Mode (Figure 6) to provide the necessary current of 120 mA.

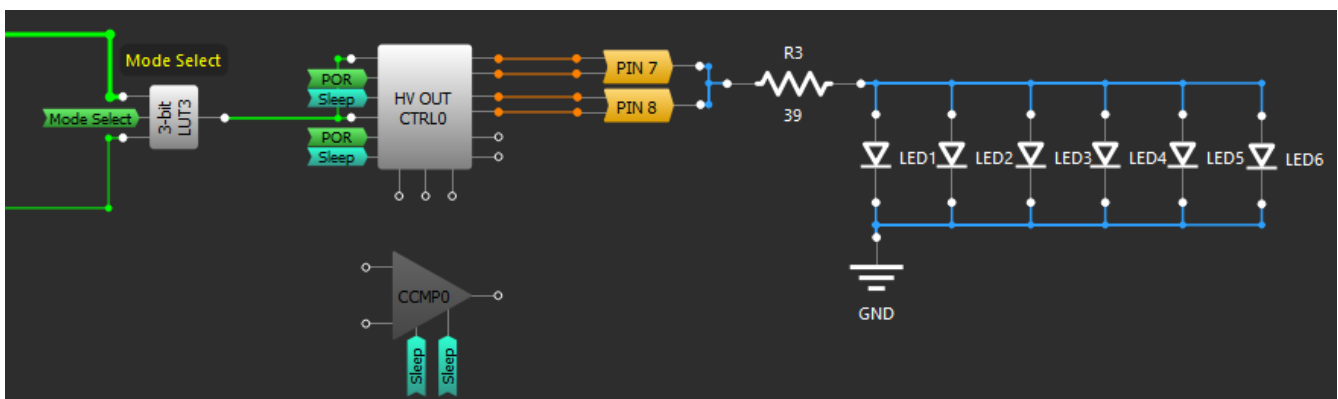

Figure 6 HV OUT Control

4.6 Motion Sensor

The lamp has a PIR motion sensor to decrease power consumption. The configuration can be found in [Figure 7](#).

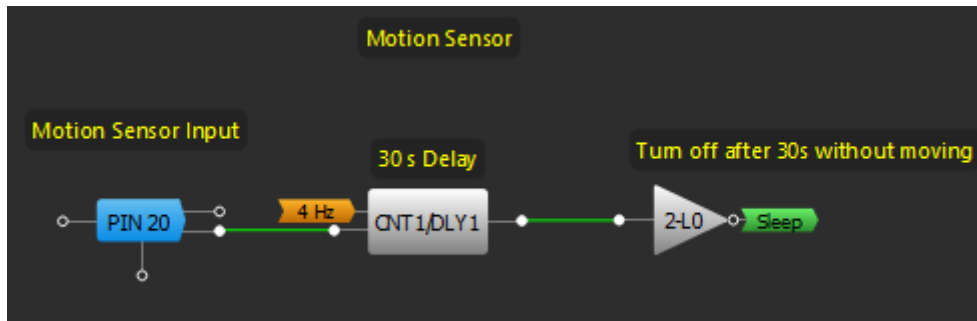

Figure 7 Motion Sensor

The CNT1 counts 30 s of Motion Sensor output. When the Sensor output is LOW more than 30 s – HV OUT CTRL and Oscillators are powered down with a HIGH Sleep signal (see [Figure 8](#)).

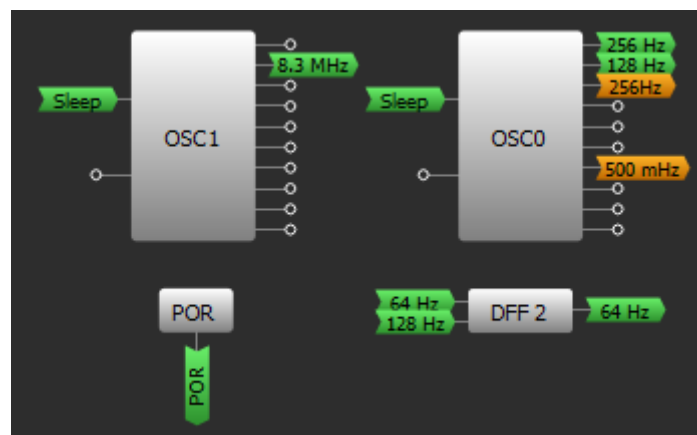

Figure 8 Oscillators Configuration

4.7 Battery Discharge Notification

As the lamp is powered by 3 batteries of 1.5 (4.5 V), the device needs a Battery Discharge Notification which helps the user not to forget to change batteries. The configuration can be found in [Figure 9](#). The Analog Comparator CMP0 with 0.5 gain compares VDD and reference voltage. If this voltage is smaller than 1952 mV, it is time to change batteries because the voltage has already decreased to 3.9 V. In this case, the red LED starts blinking with a 25% duty cycle notifying about discharge.

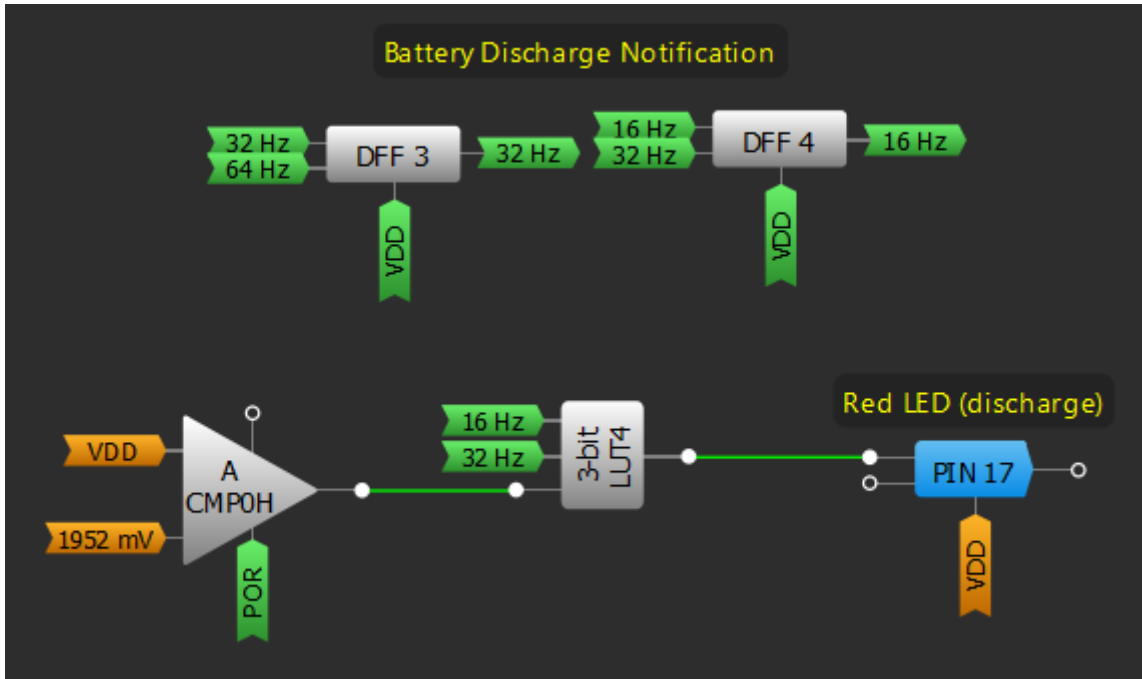

Figure 9 Battery Discharge Notification

The full circuit design can be found in Figure 10.

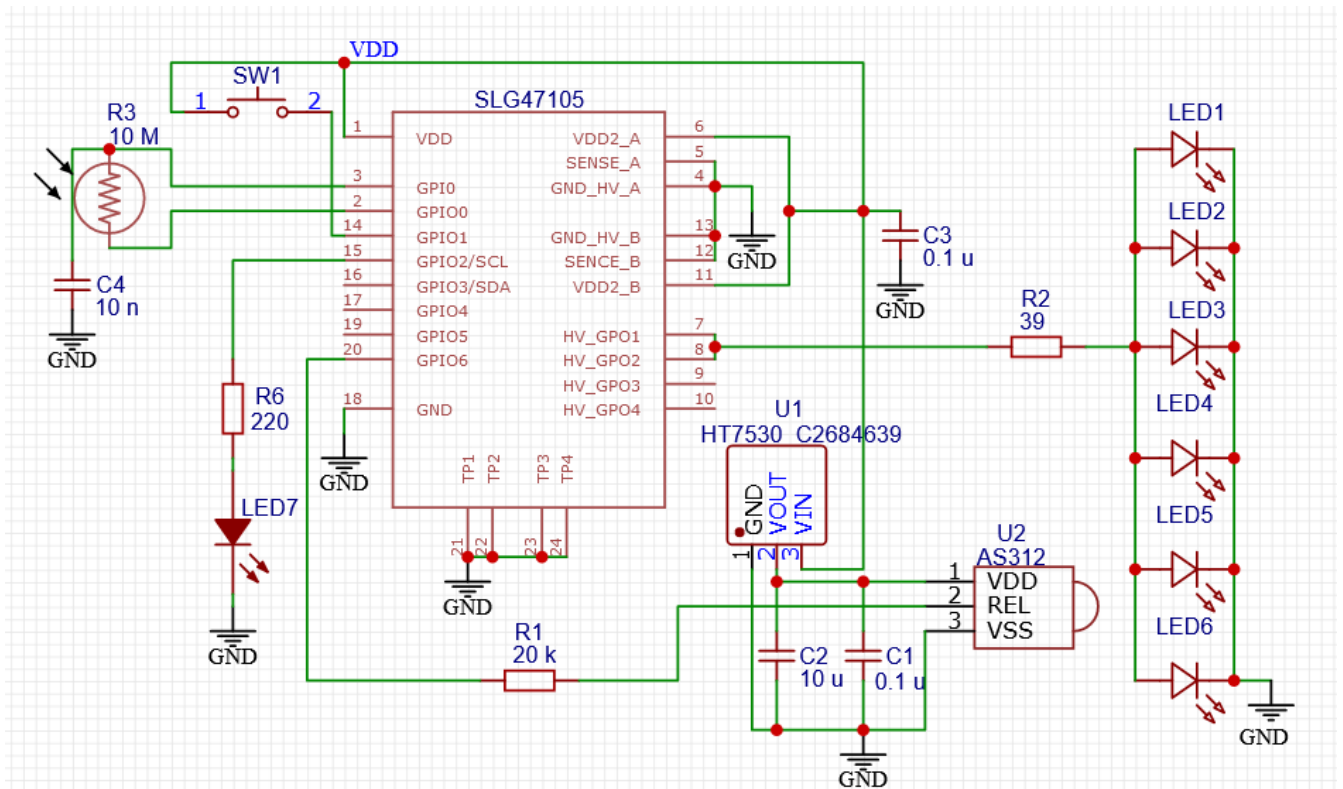

Figure 10 Full Circuit Design

5. Device Testing

To test the design, the circuit is connected to 5V (VDD, VDD_A, and VDD_B).

The oscilloscope screenshots show the Schmitt Trigger Oscillator signal (PIN 2, GPIO 0) in blue and the Intensity-Controlled Mode output (PIN 7, HV_GPO0_HD) in yellow (Figure 11 - Figure 15).

Smart Brightness-Controlled Lamp with Motion Sensor

As can be seen from these figures, the Duty Cycle of Intensity-Controlled Mode increases (decreases) when the Period of Schmitt Trigger Oscillator increases (decreases).

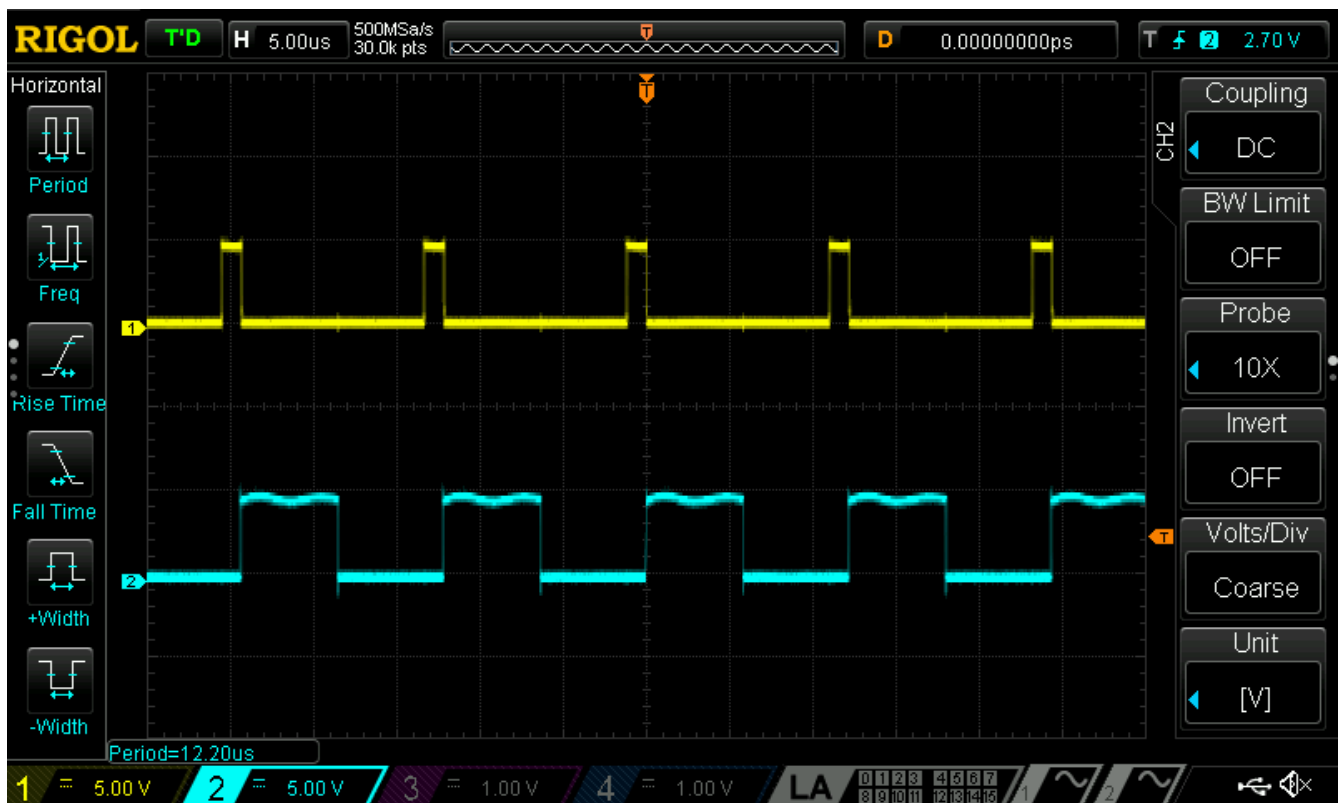

Figure 11 Period of the Schmitt Trigger Oscillator – 12.2 us

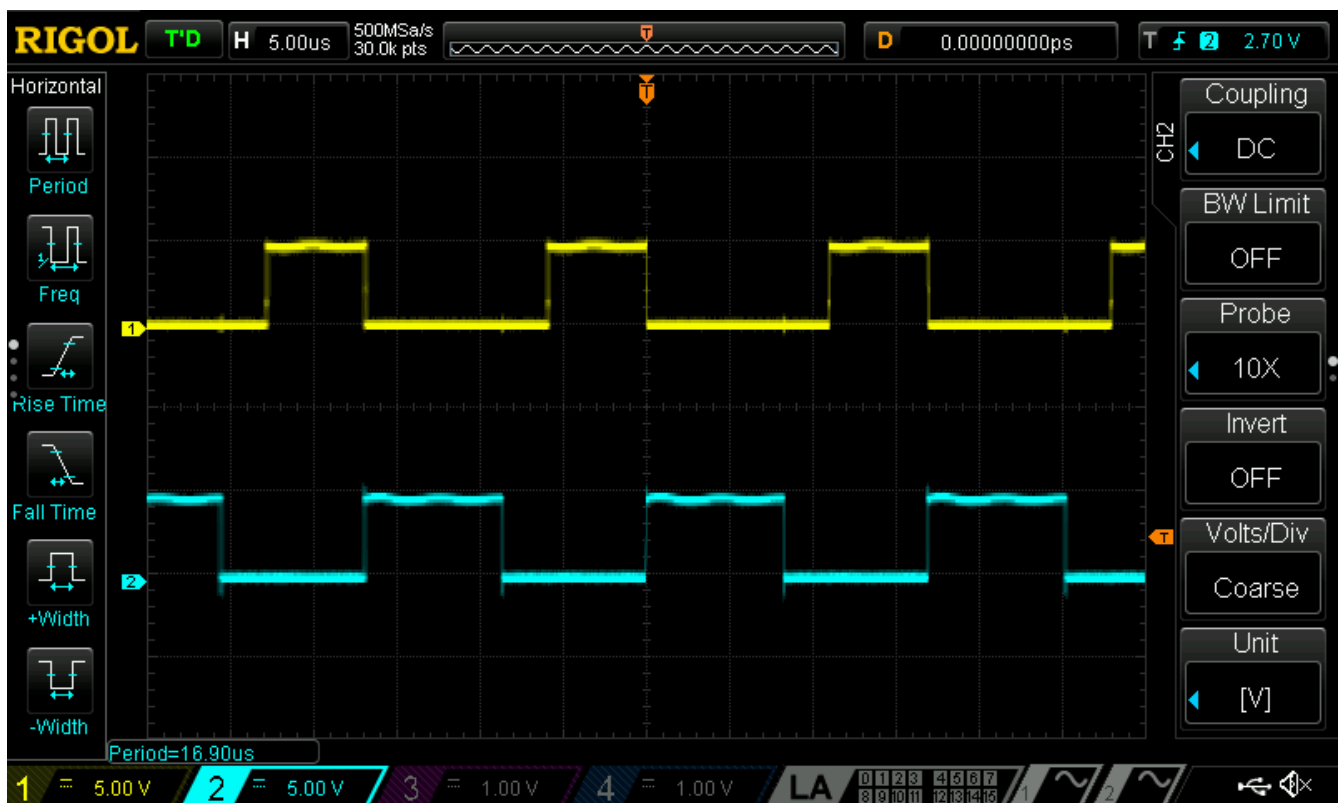

Figure 12 Period of the Schmitt Trigger Oscillator – 16.9 us

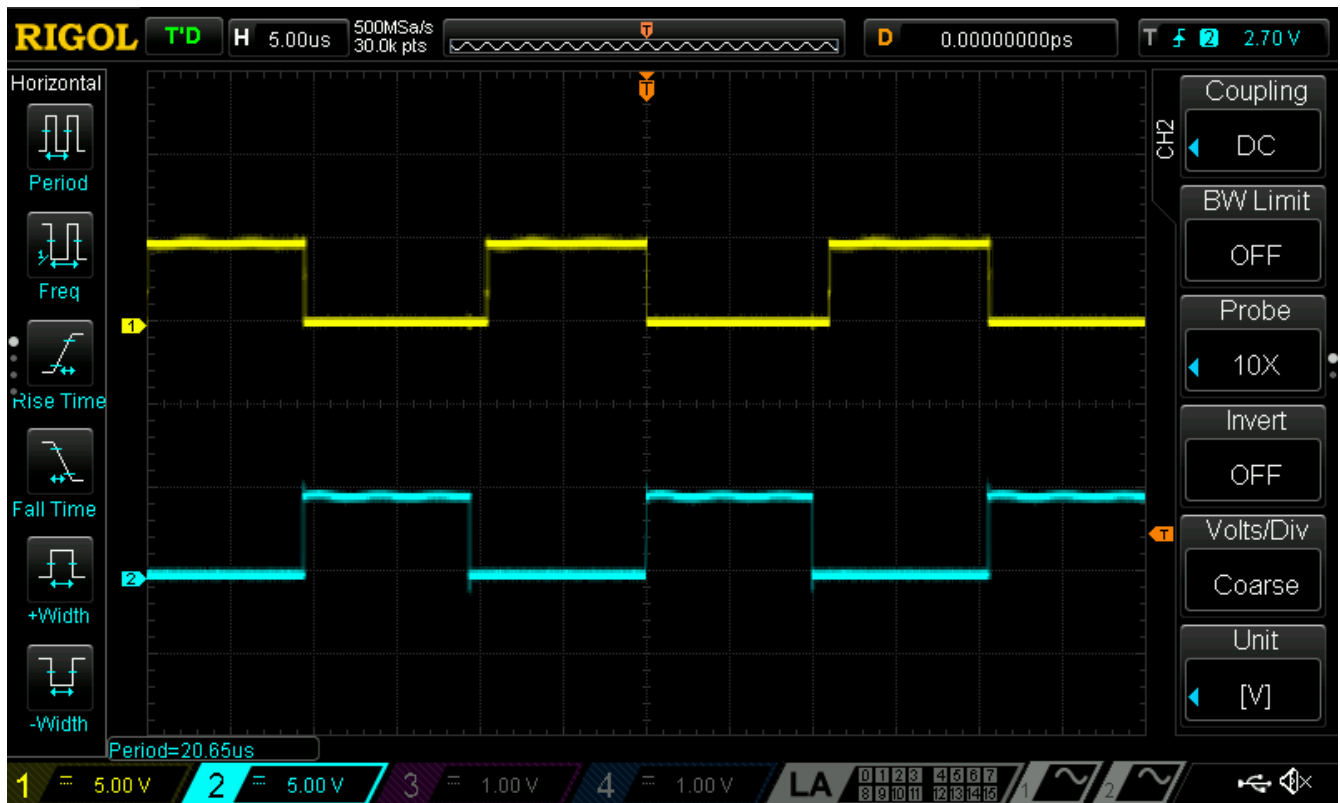

Figure 13 Period of the Schmitt Trigger Oscillator – 20.65 us

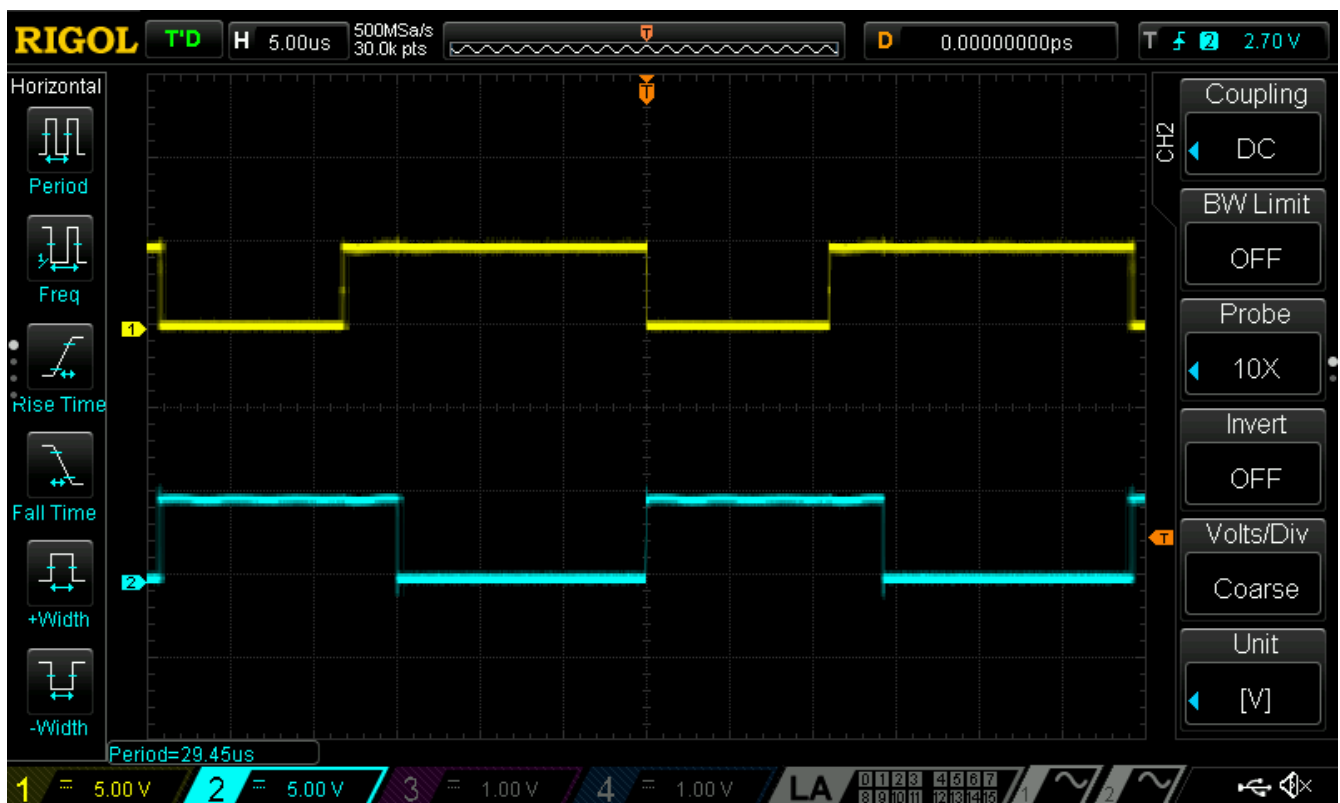

Figure 14 Period of the Schmitt Trigger Oscillator – 29.45 us

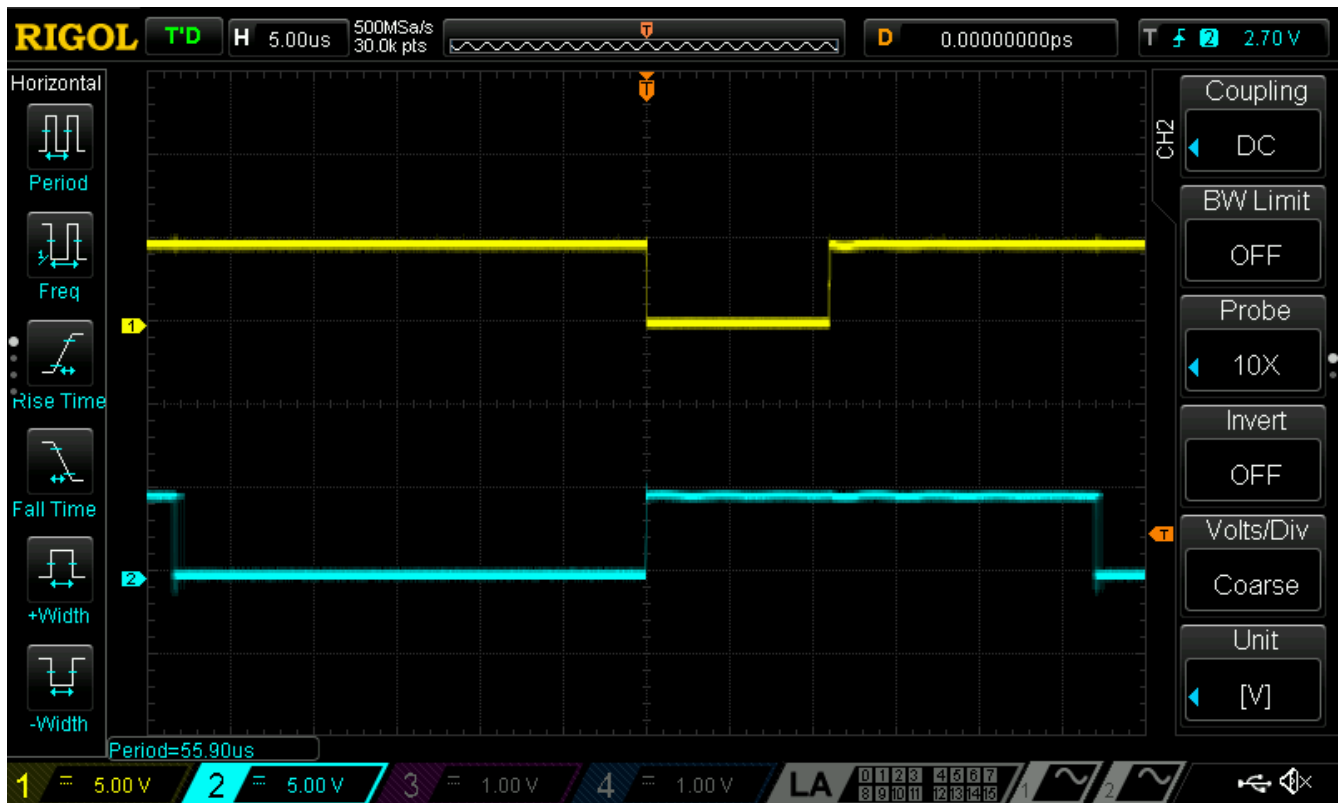

Figure 15 Period of the Schmitt Trigger Oscillator – 55.9 us

The results prove that the circuit works as expected, and the HV GreenPAK is capable of acting as the control module for LEDs.

6. Conclusion

The application note describes how to configure the HV GreenPAK to create a Smart Brightness-Controlled Lamp with Motion Sensor. It works only when the motion is detected and has two modes. The Night Mode has a constant low brightness. The Intensity-Controlled Mode varies depending on the ambient light. In addition, the Smart Lamp has a Battery Discharge Notification.

The GreenPAK's internal resources, including the HV, oscillators, logic, and GPIOs are easy to configure to implement the desired functionality for this design.

7. Revision History

Revision	Date	Description
1.00	Jun 23, 2022	Initial release.

IMPORTANT NOTICE AND DISCLAIMER

RENESAS ELECTRONICS CORPORATION AND ITS SUBSIDIARIES (“RENESAS”) PROVIDES TECHNICAL SPECIFICATIONS AND RELIABILITY DATA (INCLUDING DATASHEETS), DESIGN RESOURCES (INCLUDING REFERENCE DESIGNS), APPLICATION OR OTHER DESIGN ADVICE, WEB TOOLS, SAFETY INFORMATION, AND OTHER RESOURCES “AS IS” AND WITH ALL FAULTS, AND DISCLAIMS ALL WARRANTIES, EXPRESS OR IMPLIED, INCLUDING, WITHOUT LIMITATION, ANY IMPLIED WARRANTIES OF MERCHANTABILITY, FITNESS FOR A PARTICULAR PURPOSE, OR NON-INFRINGEMENT OF THIRD-PARTY INTELLECTUAL PROPERTY RIGHTS.

These resources are intended for developers who are designing with Renesas products. You are solely responsible for (1) selecting the appropriate products for your application, (2) designing, validating, and testing your application, and (3) ensuring your application meets applicable standards, and any other safety, security, or other requirements. These resources are subject to change without notice. Renesas grants you permission to use these resources only to develop an application that uses Renesas products. Other reproduction or use of these resources is strictly prohibited. No license is granted to any other Renesas intellectual property or to any third-party intellectual property. Renesas disclaims responsibility for, and you will fully indemnify Renesas and its representatives against, any claims, damages, costs, losses, or liabilities arising from your use of these resources. Renesas' products are provided only subject to Renesas' Terms and Conditions of Sale or other applicable terms agreed to in writing. No use of any Renesas resources expands or otherwise alters any applicable warranties or warranty disclaimers for these products.

(Disclaimer Rev.1.01)

Corporate Headquarters

TOYOSU FORESIA, 3-2-24 Toyosu,
Koto-ku, Tokyo 135-0061, Japan
www.renesas.com

Trademarks

Renesas and the Renesas logo are trademarks of Renesas Electronics Corporation. All trademarks and registered trademarks are the property of their respective owners.

Contact Information

For further information on a product, technology, the most up-to-date version of a document, or your nearest sales office, please visit www.renesas.com/contact-us/.