

# Application Note

## Ultrasonic Qualitative Distance Estimation Sensor

AN-CM-330

### Abstract

*This application note describes how to create an ultrasonic sensor using [HVPAK](#).*

*The application note comes complete with design files which can be found in the Reference section.*

---



---

**Ultrasonic Qualitative Distance Estimation Sensor**

## Contents

<b>Abstract</b> .....	<b>1</b>
<b>Contents</b> .....	<b>2</b>
<b>Figures</b> .....	<b>2</b>
<b>1 Terms and Definitions</b> .....	<b>3</b>
<b>2 References</b> .....	<b>3</b>
<b>3 Introduction</b> .....	<b>4</b>
<b>4 Interface with Ultrasonic Trigger and Receiver</b> .....	<b>4</b>
4.1 Ultrasonic Distance Sensor.....	4
4.2 Circuit Design.....	5
4.2.1 Transmitter.....	6
4.2.2 Charge Pump.....	7
4.2.3 Receiver.....	7
4.2.4 PWM.....	9
<b>5 PCB Design</b> .....	<b>9</b>
<b>6 Testing</b> .....	<b>11</b>
<b>7 Conclusion</b> .....	<b>13</b>
<b>Revision History</b> .....	<b>14</b>

## Figures

Figure 1 Ultrasonic Transmitter and Receiver .....	4
Figure 2 Block Diagram with GreenPAK .....	5
Figure 3 OSC0 Configuration .....	5
Figure 4 OSC1 Configuration .....	6
Figure 5 Circuit Diagram of Transmitter Block .....	6
Figure 6 Trigger Signal.....	7
Figure 7 Circuit Diagram of Charge Pump Block .....	7
Figure 8 Circuit Diagram of Receiver .....	8
Figure 9 Full Circuit Design .....	8
Figure 10 PWM Circuit Design .....	9
Figure 11 Top Side .....	9
Figure 12 Bottom Side.....	10
Figure 13 Photo of the Top Side .....	10
Figure 14 Photo of the Bottom Side .....	10
Figure 15 Circuit Test Measuring Distance Within the Range about 100 cm .....	11
Figure 16 Circuit Test Measuring Distance Within the Range about 200 cm .....	12
Figure 17 Circuit Test Measuring Distance Within the Range about 300 cm .....	12
Figure 18 Circuit Test Measuring Distance Within the Range about 400 cm .....	13

---

---

## Ultrasonic Qualitative Distance Estimation Sensor

### 1 Terms and Definitions

AC	Alternating current
CMP	Comparator
CNT/DLY	Counter / Delay
DC	Direct current
DFF	D Flip-Flop
GPO	General purpose output
HV	High voltage
LUT	Look-Up Table
OSC	Oscillator
PWM	Pulse width modulation

### 2 References

For related documents and software, please visit:

<https://www.dialog-semiconductor.com/configurable-mixed-signal>.

Download our free [GreenPAK Designer](#) software [1] to open the .gp files [2] and view the proposed circuit design. Use the [GreenPAK development tools](#) [3] to freeze the design into your own customized IC in a matter of minutes. Find out more in a complete library of application notes [4] featuring design examples as well as explanations of features and blocks within the GreenPAK IC.

- [1] [GreenPAK Designer Software](#), Software Download and User Guide
- [2] [AN-CM-330 Ultrasonic Qualitative Distance Estimation Sensor.gp](#), GreenPAK Design File
- [3] [GreenPAK Development Tools](#), GreenPAK Development Tools Webpage
- [4] [GreenPAK Application Notes](#), GreenPAK Application Notes Webpage
- [5] [SLG47105 Datasheet](#)

---

---

## Ultrasonic Qualitative Distance Estimation Sensor

### 3 Introduction

The main goal of this application is to design an ultrasonic qualitative distance estimation sensor using the SLG47105V. The system is designed using the HV macrocells and other internal and external components within the GreenPAK to interact with an ultrasonic sensor.

The applied methodology is based on controlling the duration of the output signal depending on the pulse reflection time. An ultrasonic pulse with the necessary width is generated by the transmitter. When this pulse reaches an obstacle, the reflected wave – echo comes back to the receiver. Then, it is possible to classify the returning echo signal using PWM.

This design can be used in a wide variety of applications, such as devices for visually impaired people, parking assist systems, robotics, warning systems, and others.

### 4 Interface with Ultrasonic Trigger and Receiver

In this designed system the transmitter sends a trigger pulse to the ultrasonic receiver every 31.25 ms. This signal is amplified by the HV part. The GreenPAK internal components, together with the ACMP, external components with the simplest amplifier stage on a bipolar transistor amplify the signal obtained by the receiver.

The HV part is necessary for increasing the amplitude of the trigger signal. ACMP and external parts with the simplest amplifier stage on a bipolar transistor are used to amplify the receiver signal. As the system keeps measuring every 31.25 ms it becomes easy to see the difference in the distances measured with the sensor.

#### 4.1 Ultrasonic Distance Sensor

The transmitter and receiver are used from the HC-SR04 sensor. They are illustrated with the following [Figure 1](#).



**Figure 1 Ultrasonic Transmitter and Receiver**

The transmitter is connected to the GreenPAK, which generates the necessary trigger signal (~10  $\mu$ s one-shot with frequency 32 Hz). The receiver catches the reflected wave signal, then the PWM output signal is generated as a way of presenting the information of the measured distance.

The block diagram is shown in the [Figure 2](#).

Ultrasonic Qualitative Distance Estimation Sensor

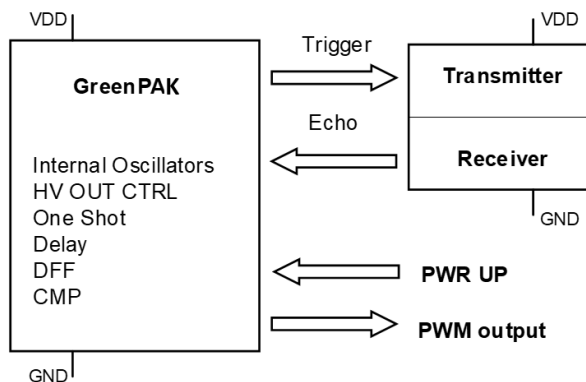

Figure 2 Block Diagram with GreenPAK

The input trigger is generated using One shot and HV OUT CTRL blocks to amplify the amplitude of the signal. The echo signal is filtered and amplified by GreenPAK ACMP and some external components. Then, using the Inverter, Delay, and DFF blocks, the PWM output signal is created. The PWM “HIGH” corresponds to the distance to the detected object. The longer the “HIGH” - the closer the object. As a result, this PWM signal can be used for different methods of notification such as driving motors, LEDs, quantitative distance estimation, and others.

4.2 Circuit Design

There are 4 main blocks in this design: Transmitter, Charge Pump, Receiver, and PWM. To reduce the power consumption of the circuit, all blocks are connected to the “PWR UP” (when PIN 16 is HIGH).

For these blocks, two oscillators with the following properties are used (Figure 3 and Figure 4).

Properties	
OSC0	
Control pin mode:	Force on
OSC power mode:	Force Power On
Clock selector:	OSC
'OSC0' frequency:	2.048 kHz
'CLK' predivider by:	8
'OUT0' second divider by:	8
'OUT1' second divider by:	1

Figure 3 OSC0 Configuration

This oscillator generates a frequency of 2.048 kHz/8/8 (32 Hz).

## Ultrasonic Qualitative Distance Estimation Sensor

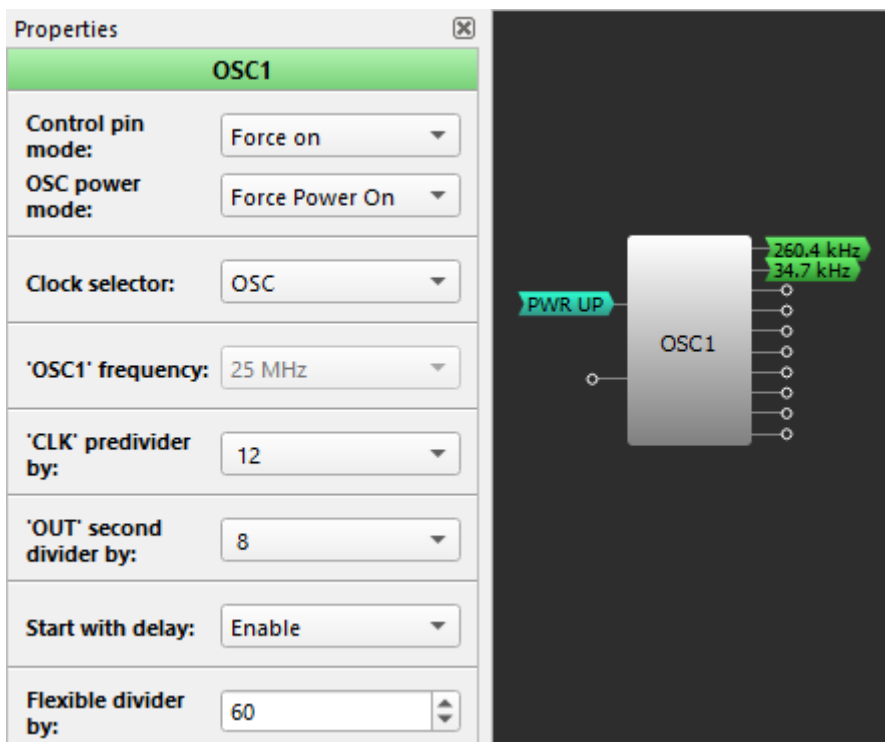
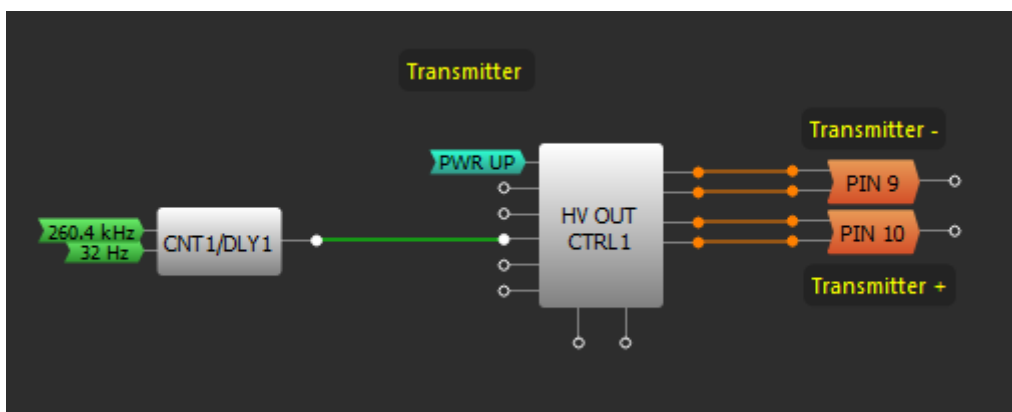

**Figure 4 OSC1 Configuration**

This oscillator generates two necessary frequencies – 25 MHz/12/8 (~260.4 kHz) and 25 MHz/12/60 (~34.7 kHz).

### 4.2.1 Transmitter

This block is used to create the trigger signal for the transmitter. The circuit diagram is shown in the Figure 5.



**Figure 5 Circuit Diagram of Transmitter Block**

The CNT1/DLY1 block is configured as a One shot. This block uses a clock of 260.4 kHz to generate a ~10 us pulse trigger signal with a frequency of 32 Hz (Figure 6). This signal goes to the HV OUT

## Ultrasonic Qualitative Distance Estimation Sensor

CTRL1 block which together with the Charge Pump block amplifies the amplitude to  $\sim 9$  V. The PIN 9 and PIN 10 serve as outputs for the transmitter.

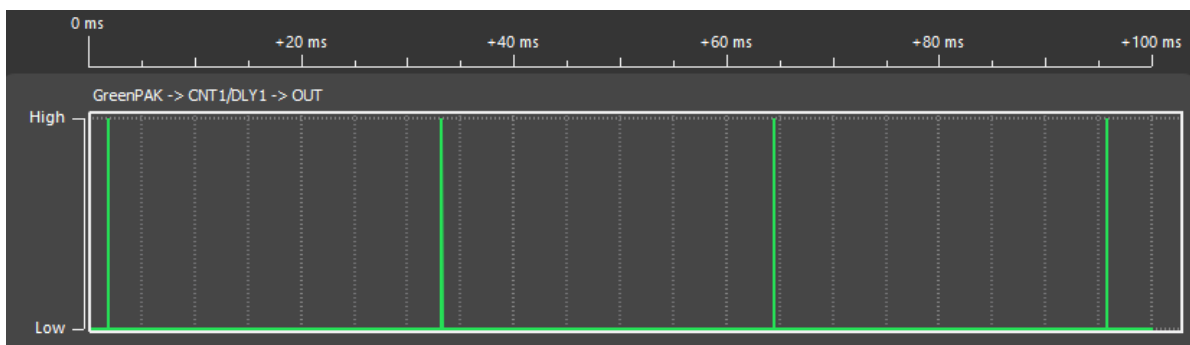

Figure 6 Trigger Signal

### 4.2.2 Charge Pump

This block is used for amplifying the trigger signal amplitude. The circuit diagram is shown in Figure 7.

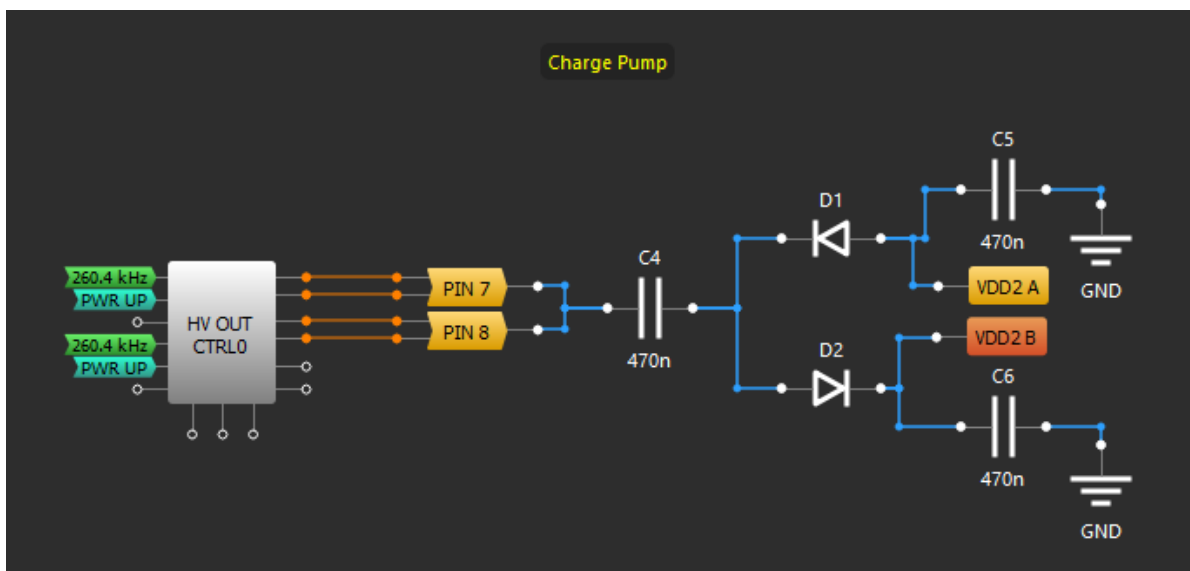

Figure 7 Circuit Diagram of Charge Pump Block

The half-bridge HV OUT CTRL0 is supplied with a 5 V DC voltage (POR). The 260.4 kHz Osc is used to create a square wave signal (AC voltage), which is needed for the Half Wave Voltage Doubler Circuit. The final voltage depends on the voltage drop of the selected diodes D1 and D2 (less than 10 V).

### 4.2.3 Receiver

This block is used for receiving, amplifying, and filtering the echo signal. The circuit diagram is shown in the Figure 8.

Ultrasonic Qualitative Distance Estimation Sensor

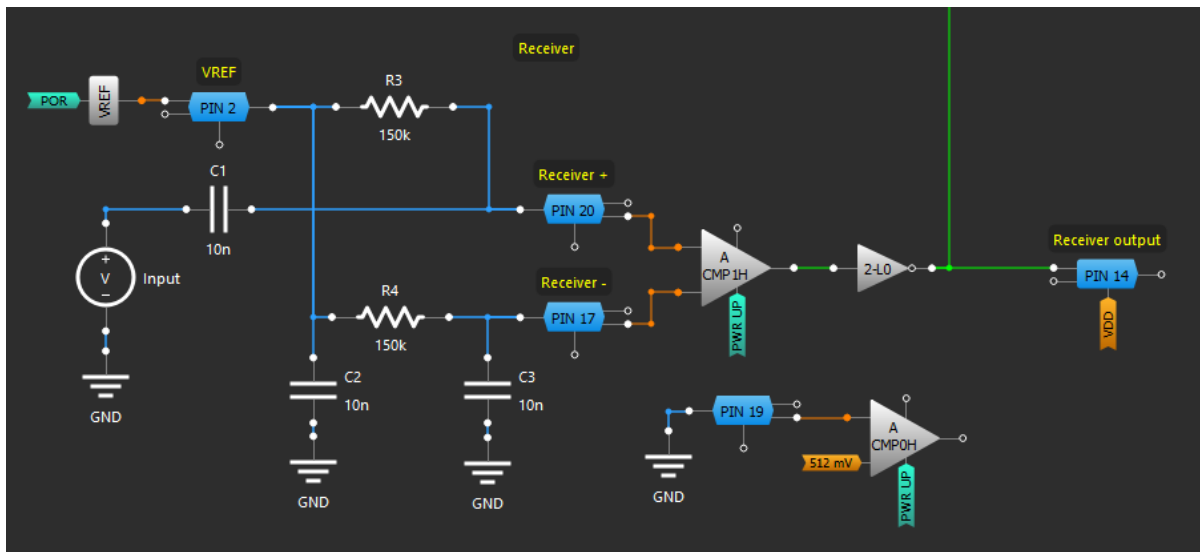

Figure 8 Circuit Diagram of Receiver

Before the GreenPAK, the echo signal goes to the simplest amplifier stage on a bipolar transistor, which amplifies it (Figure 9). Then the echo signal reaches the CMP1 block, where the useful signal is selected. This inverted signal is the receiver's output (PIN 14). The receiver signal (PIN 14, GPIO1) is used only for testing. For the final PCB, the PWM output (PIN 15, SCL/GPIO2) is used.

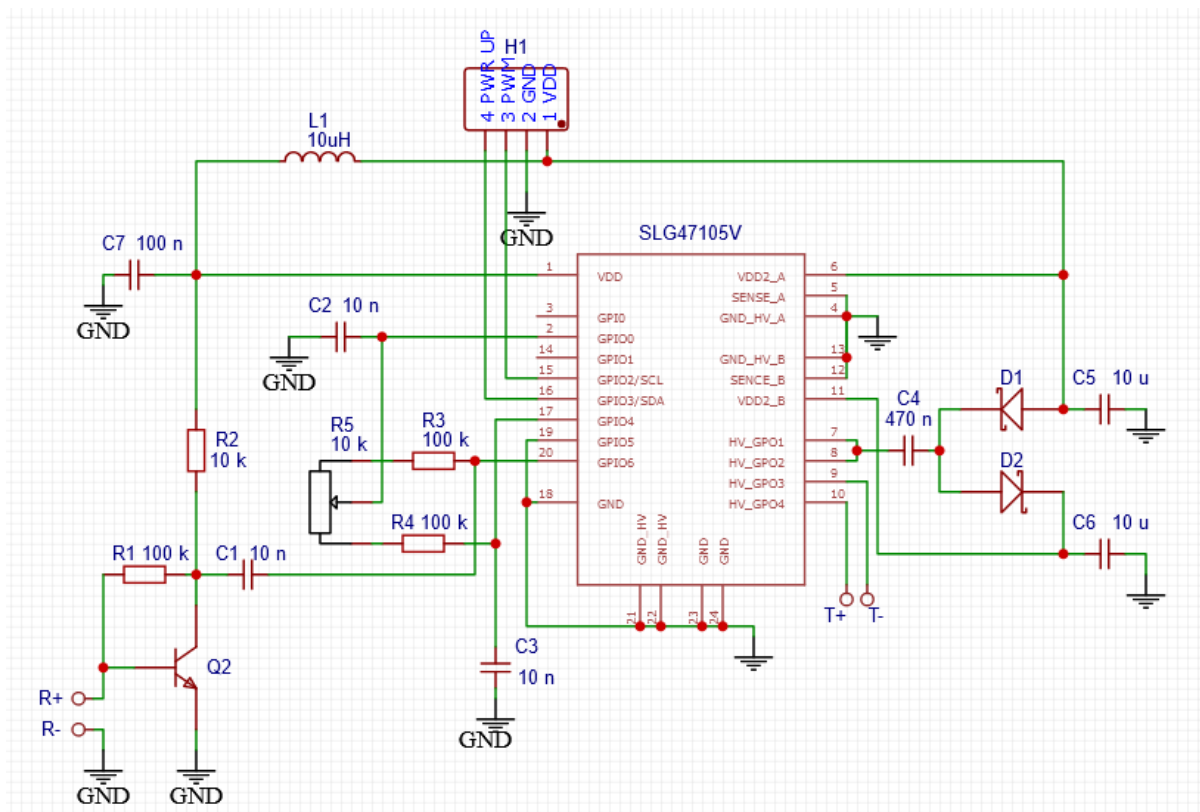

Figure 9 Full Circuit Design

As can be seen in Figure 9, there is a potentiometer R5. This potentiometer is needed to adjust the CMP1 threshold (a few mV) to obtain suitable sensitivity of the sensor.

## Ultrasonic Qualitative Distance Estimation Sensor

### 4.2.4 PWM

This block is necessary to create a way of the received signal perception. Also, it is needed for further signal processing and its application (Figure 10).

The main idea is to create a square wave signal which is HIGH from the trigger signal to the beginning of the echo signal. As the phase of the echo signal changes depending on the distance to the obstacle, the duration of HIGH PWM also changes.

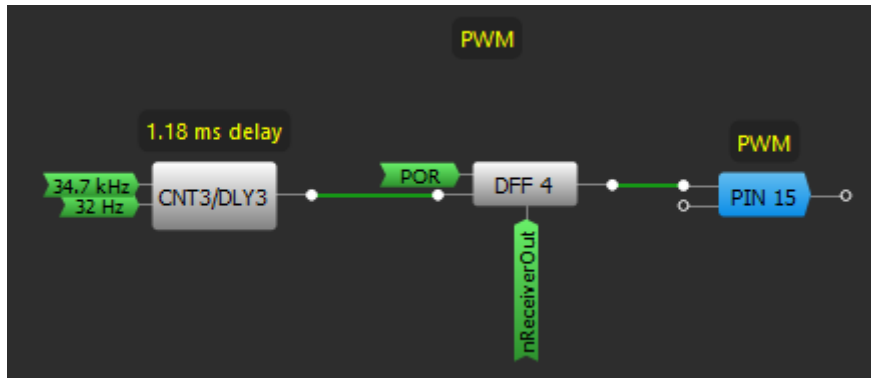

Figure 10 PWM Circuit Design

During testing the circuit, there has been noticed, that the receiver catches the parasitic signal from the transmitter from 0 to ~20 cm. To skip this useless signal, the configured as a Delay CNT3/DLY3 block is added. The typical delay time is about 1.18 ms.

## 5 PCB Design

Here is a proposed PCB design (Figure 11 and Figure 12) for this application, which is based on the schematic in the Figure 9. Also, there are photos of the working prototype (Figure 13 and Figure 14).

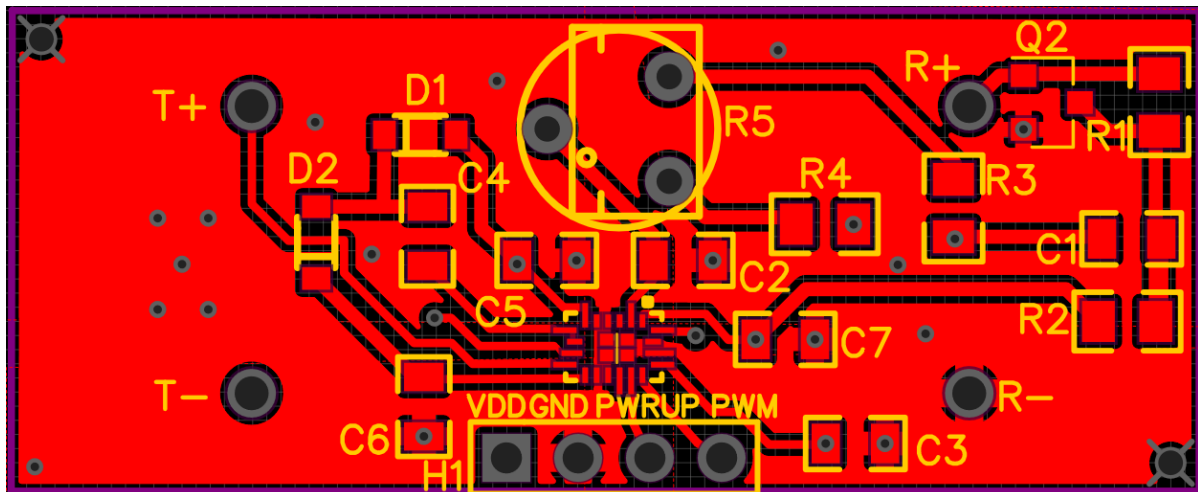

Figure 11 Top Side

Ultrasonic Qualitative Distance Estimation Sensor

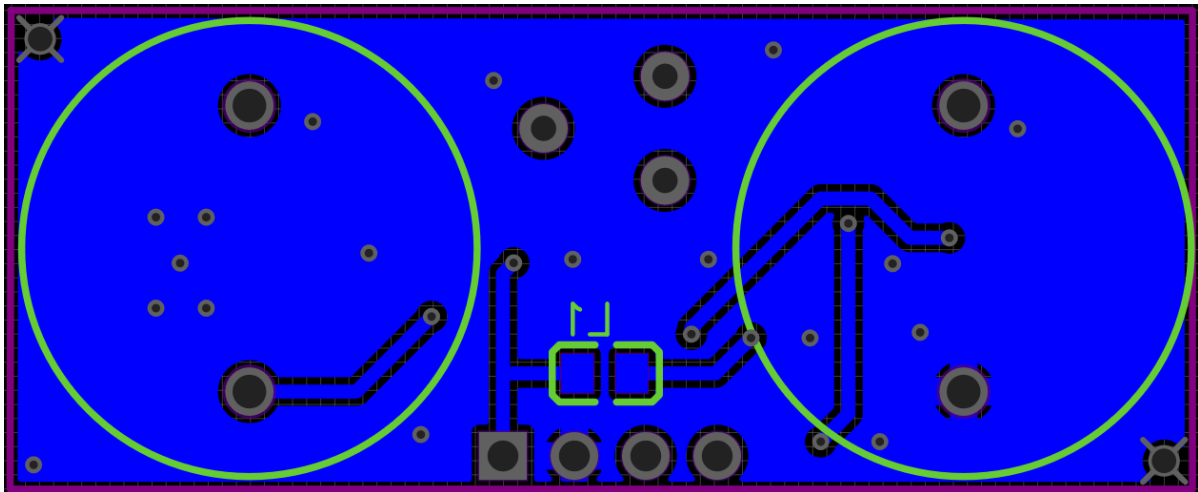

Figure 12 Bottom Side

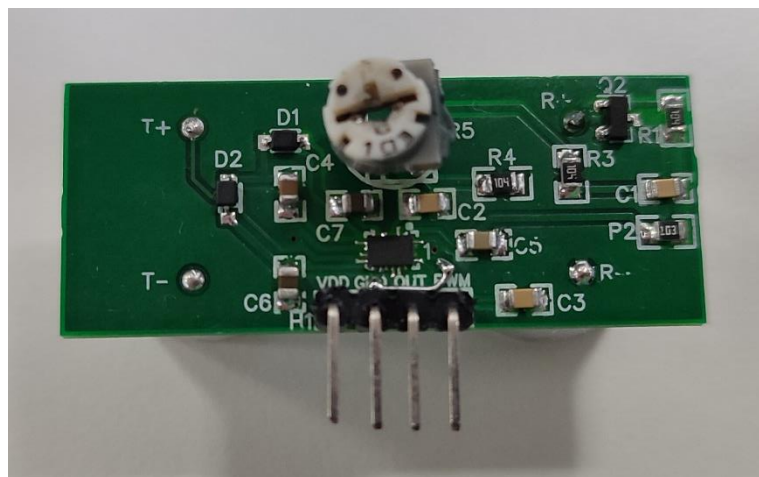

Figure 13 Photo of the Top Side

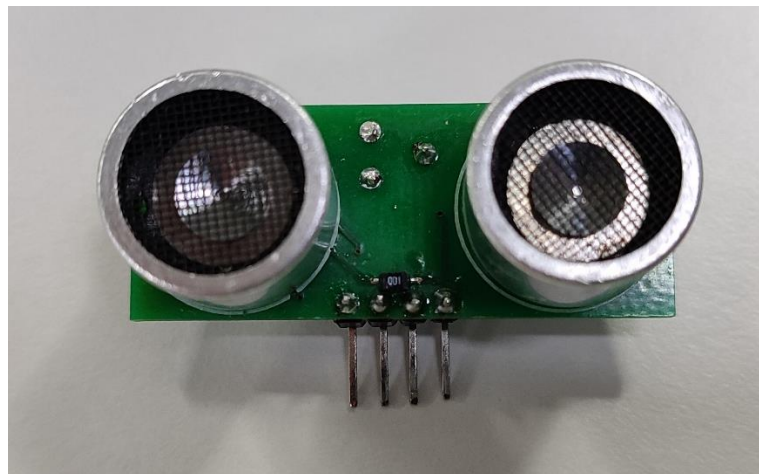

Figure 14 Photo of the Bottom Side

## Ultrasonic Qualitative Distance Estimation Sensor

## 6 Testing

To test the design, the circuit is connected to 5V (VDD) and the PWR UP is set HIGH.

The example of the results of the measured distance are presented as follows: 100 cm in the [Figure 15](#), 200 cm in the [Figure 16](#), 300 cm in the [Figure 17](#), and 400 cm in [Figure 18](#). The oscilloscope screenshots show the transmitter signal (PIN 9, HV\_GPO2\_HD), the receiver signal (PIN 14, GPIO1), and the PWM (PIN 15, SCL/GPIO2).

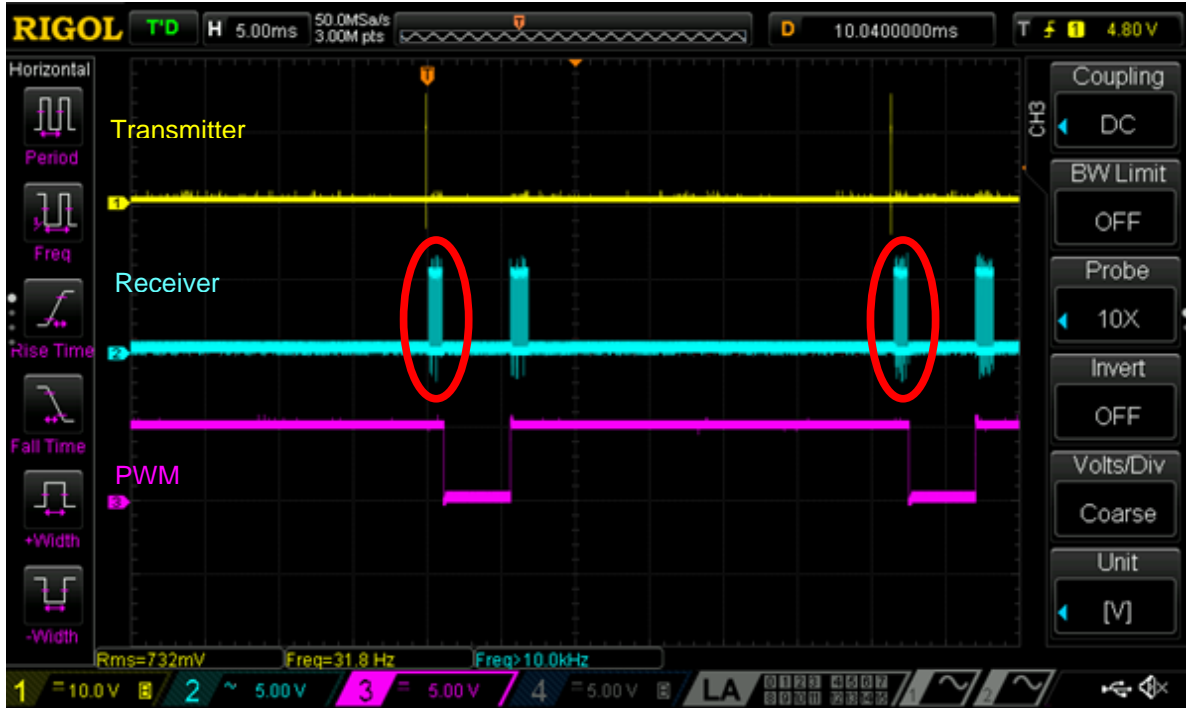

Figure 15 Circuit Test Measuring Distance Within the Range about 100 cm

Ultrasonic Qualitative Distance Estimation Sensor

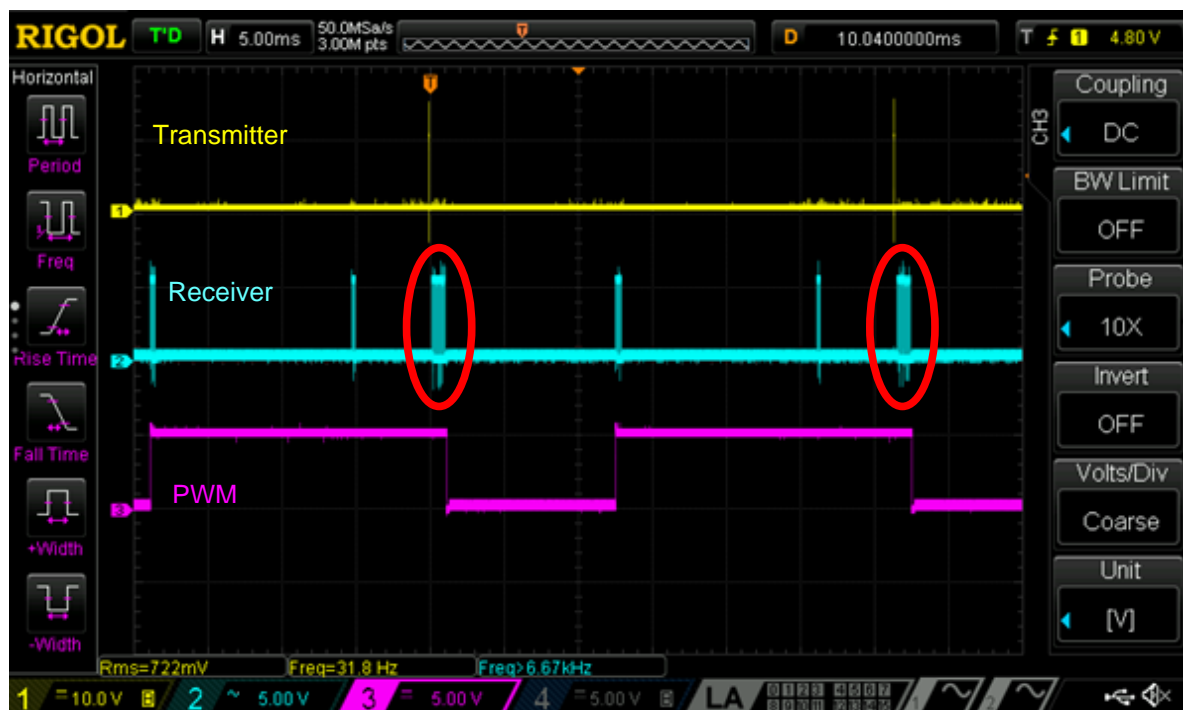

Figure 16 Circuit Test Measuring Distance Within the Range about 200 cm

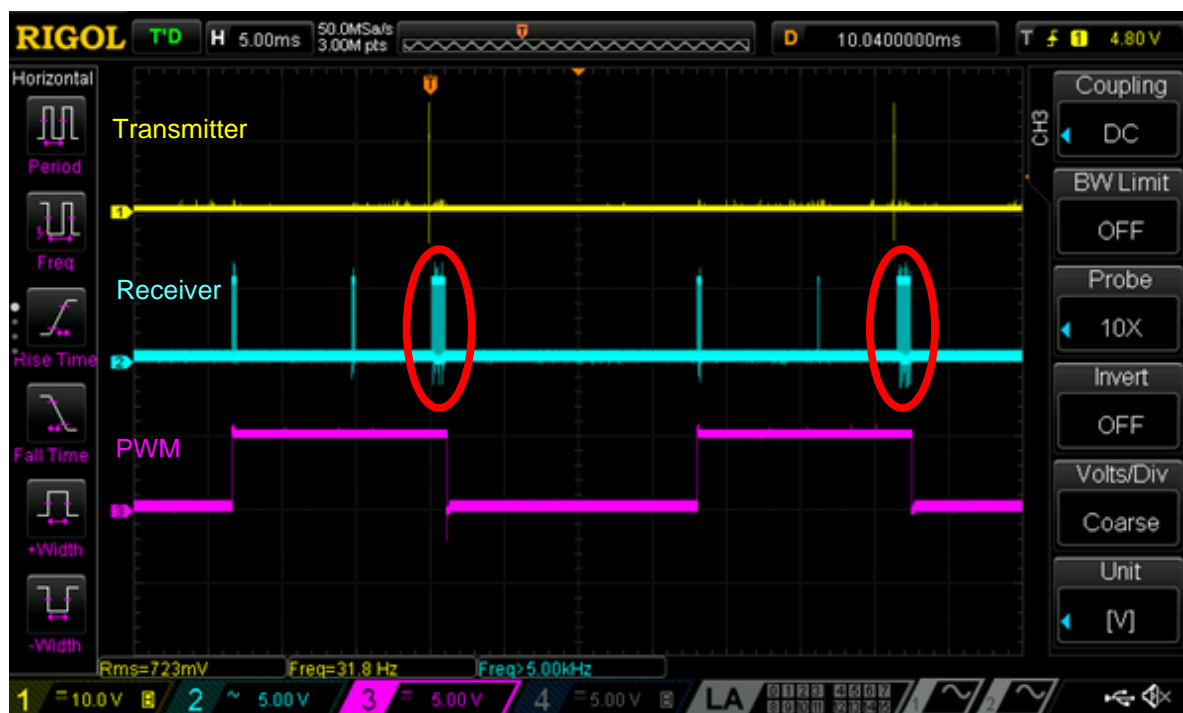

Figure 17 Circuit Test Measuring Distance Within the Range about 300 cm

## Ultrasonic Qualitative Distance Estimation Sensor

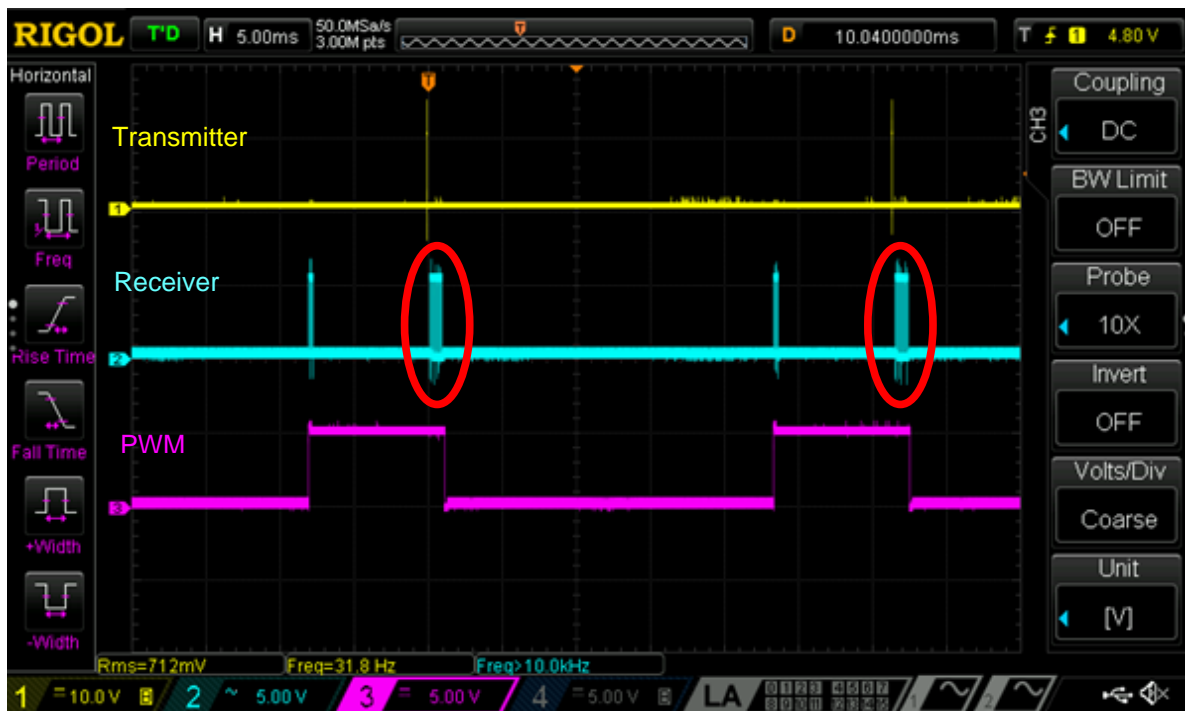

Figure 18 Circuit Test Measuring Distance Within the Range about 400 cm

As can be seen in these figures, the receiver catches the parasitic signal (these glitches are circled in red) from the transmitter from 0 to ~20 cm (4.2.4 PWM).

The results prove that the circuit works as expected, and the GreenPAK module is capable of acting as the control module for the ultrasonic qualitative distance estimation sensor. It measures a distance from 20 cm to about 400 cm.

## 7 Conclusion

The application note describes how to configure the HV GreenPAK as a control unit to drive the transducers and interpret the receiver's echo pulse output using the PWM to create an ultrasonic qualitative distance estimation sensor. The described ultrasonic sensor measures distance from 20 cm to about 400 cm.

The GreenPAK's internal resources, including the HV, oscillators, logic, and GPIOs are easy to configure to implement the desired functionality for this design.

**Revision History**

<b>Revision</b>	<b>Date</b>	<b>Description</b>
1.0	31-Jan-2022	Initial Version

## IMPORTANT NOTICE AND DISCLAIMER

RENESAS ELECTRONICS CORPORATION AND ITS SUBSIDIARIES (“RENESAS”) PROVIDES TECHNICAL SPECIFICATIONS AND RELIABILITY DATA (INCLUDING DATASHEETS), DESIGN RESOURCES (INCLUDING REFERENCE DESIGNS), APPLICATION OR OTHER DESIGN ADVICE, WEB TOOLS, SAFETY INFORMATION, AND OTHER RESOURCES “AS IS” AND WITH ALL FAULTS, AND DISCLAIMS ALL WARRANTIES, EXPRESS OR IMPLIED, INCLUDING, WITHOUT LIMITATION, ANY IMPLIED WARRANTIES OF MERCHANTABILITY, FITNESS FOR A PARTICULAR PURPOSE, OR NON-INFRINGEMENT OF THIRD-PARTY INTELLECTUAL PROPERTY RIGHTS.

These resources are intended for developers who are designing with Renesas products. You are solely responsible for (1) selecting the appropriate products for your application, (2) designing, validating, and testing your application, and (3) ensuring your application meets applicable standards, and any other safety, security, or other requirements. These resources are subject to change without notice. Renesas grants you permission to use these resources only to develop an application that uses Renesas products. Other reproduction or use of these resources is strictly prohibited. No license is granted to any other Renesas intellectual property or to any third-party intellectual property. Renesas disclaims responsibility for, and you will fully indemnify Renesas and its representatives against, any claims, damages, costs, losses, or liabilities arising from your use of these resources. Renesas' products are provided only subject to Renesas' Terms and Conditions of Sale or other applicable terms agreed to in writing. No use of any Renesas resources expands or otherwise alters any applicable warranties or warranty disclaimers for these products.

(Disclaimer Rev.1.01)

### Corporate Headquarters

TOYOSU FORESIA, 3-2-24 Toyosu,  
Koto-ku, Tokyo 135-0061, Japan  
[www.renesas.com](http://www.renesas.com)

### Trademarks

Renesas and the Renesas logo are trademarks of Renesas Electronics Corporation. All trademarks and registered trademarks are the property of their respective owners.

### Contact Information

For further information on a product, technology, the most up-to-date version of a document, or your nearest sales office, please visit [www.renesas.com/contact-us/](http://www.renesas.com/contact-us/).