

Application Note

GreenPAK in Solar Systems Maximum Power Point Trackers MPPT

AN-CM-284

Abstract

This Application note describes how to use GreenPAK for the full system of Maximum Power Point Tracker in Solar Systems.

GreenPAK in Solar Systems Maximum Power Point Trackers MPPT

Contents

Abstract	1
Contents	2
Figures	2
Tables	3
1 Terms and Definitions	4
2 References	4
3 Introduction	5
3.1 Does GreenPAK Replace All the Components? And for All the Known MPPT Algorithms?	5
3.2 Photovoltaic Cell Characteristics	5
3.3 System Block Diagrams	6
3.4 How It Works	8
3.4.1 System Blocks Implementation	9
3.4.1.1 PV cell Current Sensing	9
3.4.1.2 PV Cell Voltage Sensing	9
3.4.1.3 Duty Cycle Updater and Stability Study:.....	9
3.5 Hardware Connection and Testing Results	10
3.5.1 PV Cell Emulator	10
3.5.2 Validation Tests:	11
3.5.3 Start-up Duty Cycle Increase.....	11
3.5.4 Testing the Duty Updater Frequency:.....	12
3.5.5 Instability Example	12
3.5.6 Power Stage Circuit	12
4 Conclusions	14
Revision History	15

Figures

Figure 1: VI & PV Curve of a Photovoltaic Cell	5
Figure 2: MPPT Per Panel System Diagram.....	6
Figure 3: MPPT Replacement with GreenPAK	6
Figure 4: MPPT Implementation with GreenPAK (a)	7
Figure 5: MPPT Implementation with GreenPAK (b)	7
Figure 6: Operation Regions on a PI Curve	8
Figure 7: Current Sensing Block	9
Figure 8: Voltage Sensing Block	9
Figure 9: Duty Cycle Update Block	10
Figure 10: Photovoltaic Modelling	11
Figure 11: Duty Cycle Measurements	11
Figure 12: Duty Cycle Updater Output Testing	12
Figure 13: Instability Example	12
Figure 14: Power Stage (Boost Converter)	13
Figure 15: PC Cell Voltage with the Operation of the MPPT	13

**GreenPAK in Solar Systems Maximum Power Point
Trackers MPPT**

Tables

Table 1: Pin Configuration of the GreenPAK..... 8

GreenPAK in Solar Systems Maximum Power Point Trackers MPPT

1 Terms and Definitions

MPPT	Maximum power point tracker
MPP	Maximum power point
OV	Open circuit voltage
SC	Short circuit current
SW	Switching frequency
DC	Duty cycle

2 References

For related documents and software, please visit:

[GreenPAK™ Programmable Mixed-Signal Products | Renesas](#)

Download our free [GreenPAK™ Designer](#) software [1] to open the .gp files [1] and view the proposed circuit design. Use the [GreenPAK development tools](#) [3] to freeze the design into your own customized IC in a matter of minutes. Find out more in complete library of application notes [4] featuring design examples as well as explanations of features and blocks within the GreenPAK IC.

- [1] [Go Configure™ Software Hub | Renesas](#), Software Download and User Guide
- [2] [AN-CM-284 GreenPAK in Solar Systems Maximum Power Point Trackers MPPT.gp](#), [GreenPAK Design File](#)
- [3] [GreenPAK Development Tools | Renesas](#), [GreenPAK Development Tools Webpage](#)
- [4] [GreenPAK Application Notes | Renesas](#), [GreenPAK Application Notes Webpage](#)
- [5] “Predictive & Adaptive MPPT Perturb and Observe Method”, IEEE Transactions on Aerospace and Electronic Systems (Volume: 43, Issue: 3, July 2007)
- [6] “Optimization of perturb and observe maximum power point tracking method”, IEEE Transactions on Power Electronics (Volume: 20, Issue: 4, July 2005).

GreenPAK in Solar Systems Maximum Power Point Trackers MPPT

3 Introduction

The PV panels are special power supplies that deliver a green and renewable power. PV panels have non-constant power based on many parameters (sun irradiation and angle, shadow percentage, temperature and hotspot effect issue). The solar panel contains a matrix of solar cells that converts the sun irradiation to power. Connecting more cells in a matrix delivers more power but only 23 – 40 % of the maximum power. The MPPTs “Maximum power point trackers” are made to push the solar panel to work at the maximum power point in the power curve. The solar cells in the matrix are not equal and the irradiation & sun angle is not equal over them. While using one MPPT per panel increases the maximum power generated to 65 % of the actual power that the panel can deliver. Using MPPT per cell is expensive as it uses many components and the board would be bigger than the cell itself. GreenPAK can solve this dilemma by replacing the huge number of components in the MPPT systems by a GreenPAK IC with inductor or a single GreenPAK and a capacitor bank for the matrix.

3.1 Does GreenPAK Replace All the Components? And for All the Known MPPT Algorithms?

GreenPAK can replace the MPPT controllers and sensors, but MOSFETs and the power inductor make up about 70 % of the MPPT circuit. GreenPAK is suitable for almost all MPPT algorithms like perturb and observe, fuzzy control etc.

3.2 Photovoltaic Cell Characteristics

The Figure 1 below shows the VI & PI curve of a photovoltaic cell indicating the maximum power point in the curve.

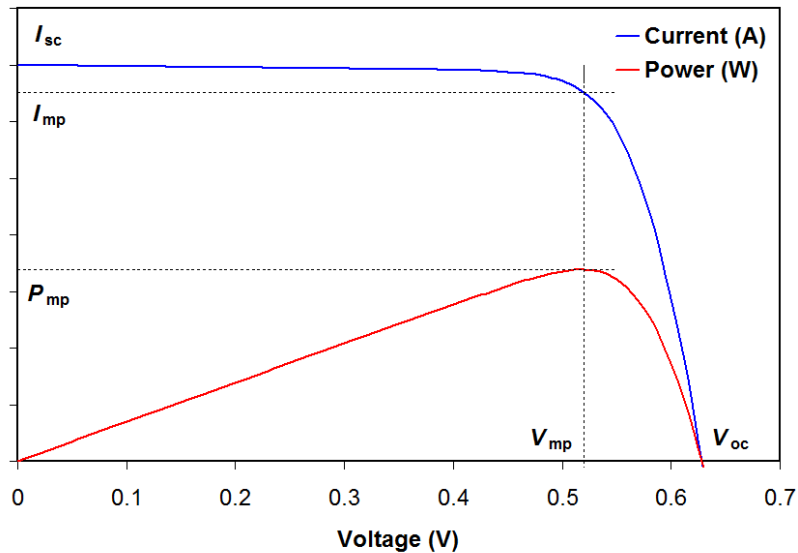

Figure 1: VI & PV Curve of a Photovoltaic Cell

The system is an implementation of one of the MPPT algorithms to get the maximum power of a cell. Shown in the Figure 2 is the main connection of a big panel that contains a matrix of PV cells with one Boost converter and MPPT controller.

GreenPAK in Solar Systems Maximum Power Point Trackers MPPT

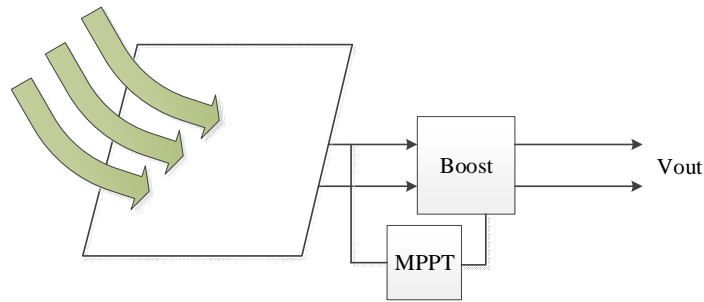

Figure 2: MPPT Per Panel System Diagram

3.3 System Block Diagrams

This application note shows you how to create your own PV source that you can add to your system for renewable power charging. You will need fewer components to get the system working. A [GreenPAK](#), two MOSFETs and an inductor are needed for this system instead of a big circuit to implement the MPPT algorithm.

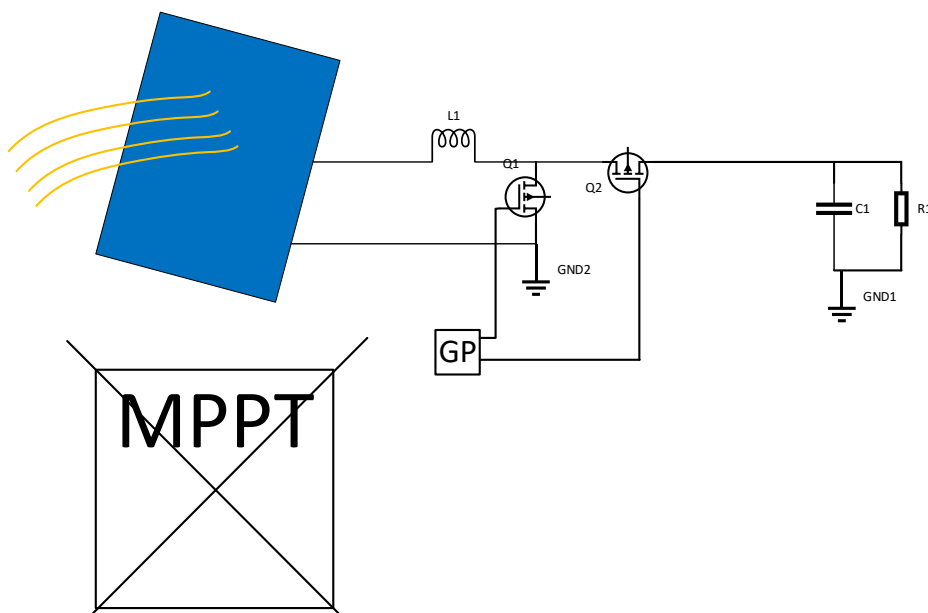

Figure 3: MPPT Replacement with GreenPAK

Figure 3 shows the advantages of having a [GreenPAK](#) in the system. Mainly the size reduction and fast design are the advantages of using [GreenPAK](#) in this application. The circuit can be attached to the PV cell to get a portable PV charger with full features of stability monitoring and protection.

Figure 4 shows the MPPT implementation with [GreenPAK](#). The design keeps the system working at the maximum power point of the PV cell to a tolerance of 2.5%.

GreenPAK in Solar Systems Maximum Power Point Trackers MPPT

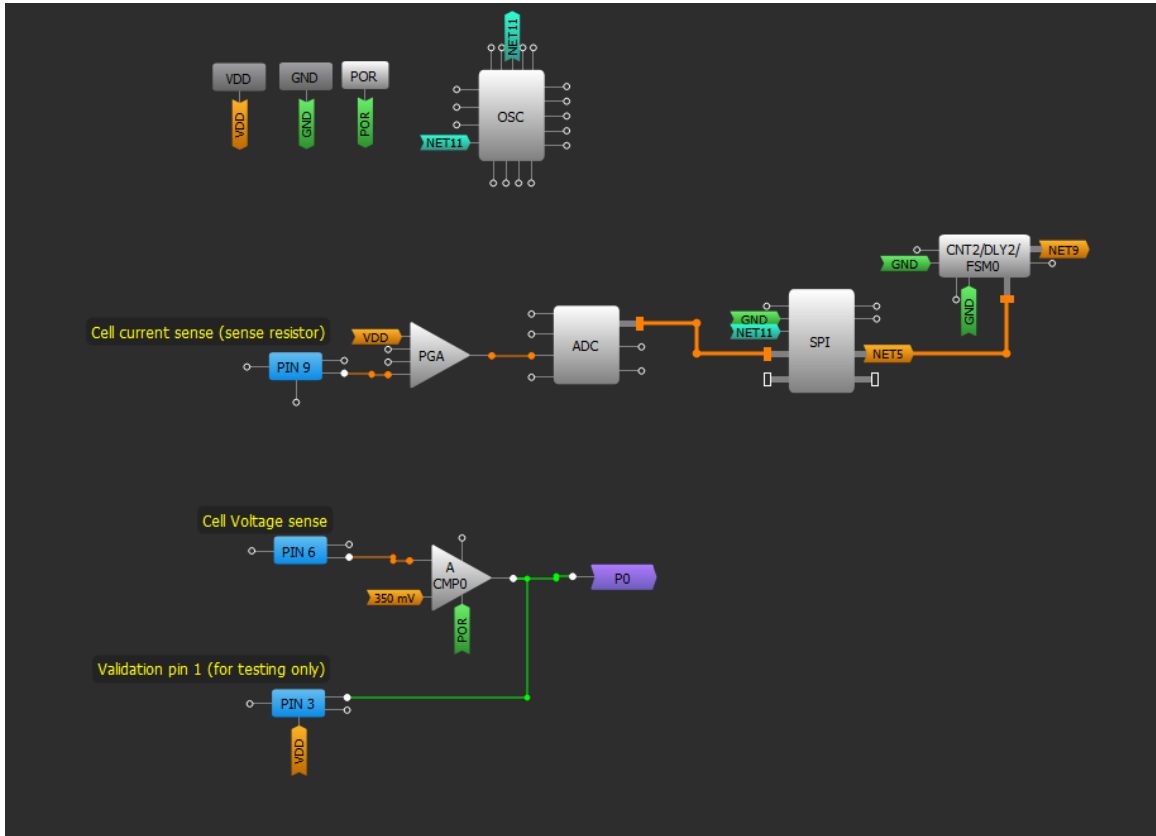

Figure 4: MPPT Implementation with GreenPAK (a)

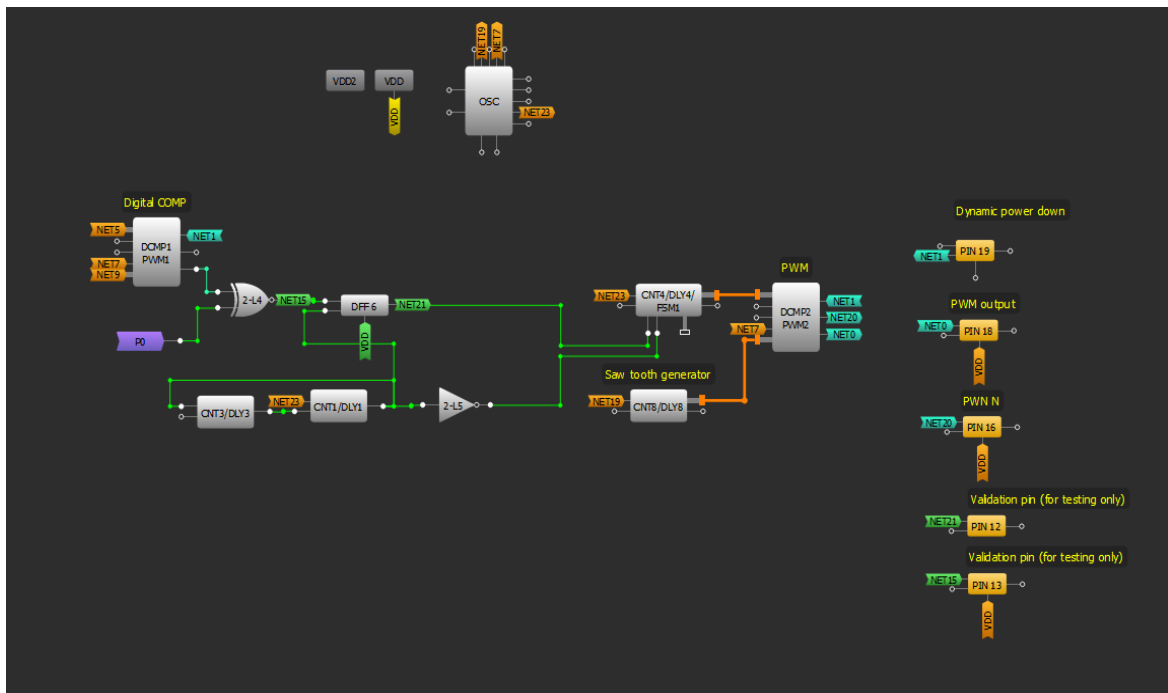

Figure 5: MPPT Implementation with GreenPAK (b)

Pins configuration:

GreenPAK in Solar Systems Maximum Power Point Trackers MPPT

Table 1: Pin Configuration of the GreenPAK

#	PIN	Setup	Description
1	PIN3	OUTPUT	Validation pin, for testing only
2	PIN6	INPUT	Vsense, an analogue input to sense the PV Cell voltage
3	PIN9	INPUT	I sense, an analogue input to sense the PV Cell current from a Rsense
4	PIN12	OUTPUT	Validation pin, for testing only
5	PIN13	OUTPUT	Validation pin, for testing only
6	PIN16	OUTPUT	PWM High side, connect to Q2 in power converter
7	PIN18	OUTPUT	PWM Low side, connect to Q1 in power converter
8	PIN19	OUTPUT	Dynamic power down

3.4 How It Works

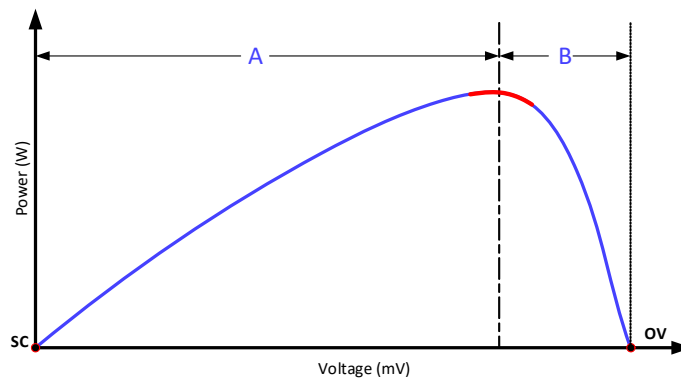

Figure 6: Operation Regions on a PI Curve

The circuit will be connected to a current sense resistor to determine the current difference and sensing the output voltage at the same time. To force the system producing the maximum power we push the operating point to the maximum power point by sensing the input current and voltage to determine if the system is at MPP or not. The system determines if the running voltage is below or higher than the MPP. We can divide the voltage-power curve into two regions, Region A at left and region B at right of the maximum power point as shown in Figure 6. The GreenPAK will determine if the voltage is in region A or B.

Sensing the current and voltage helps the system to update the duty cycle based on the ΔI and voltage value, this will help the MPPT to determine if the system at a region A or B (see Figure 6) then update the PWM value based on this decision to move the operating point toward the MPP. The MPPT starts from the open load point (V max @ no output current) then moves to the MPP and oscillates around it until changes happen in one of the parameters (sun Irradiation, shadow and temperature). By changing the shadow, sun angle, TEMP, or sudden shadow happened, the cell will continue delivering the maximum power it can deliver without affecting the rest of cells in the matrix.

To create a power plant, the user can easily attach the GreenPAK to each cell to get maximum power of the cell but the output voltage isn't a steady value as the main aim is maximum power. The

GreenPAK in Solar Systems Maximum Power Point Trackers MPPT

user can use any DC-DC converter to get the suitable voltage for his system based on the application.

3.4.1 System Blocks Implementation

Implementing the block diagram shown in [Figure 5](#) using GreenPAK SLG46621V in detail.

3.4.1.1 PV cell Current Sensing

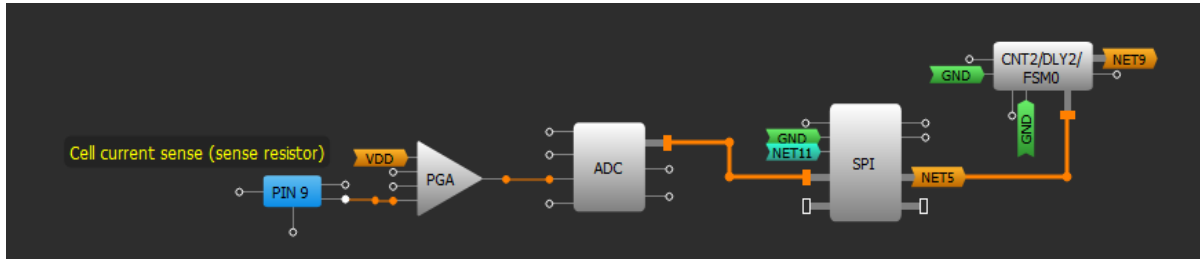

Figure 7: Current Sensing Block

Sensing the current is a good way to improve the system accuracy of updating the duty cycle and to have limitations not to hit the short circuit point.

3.4.1.2 PV Cell Voltage Sensing

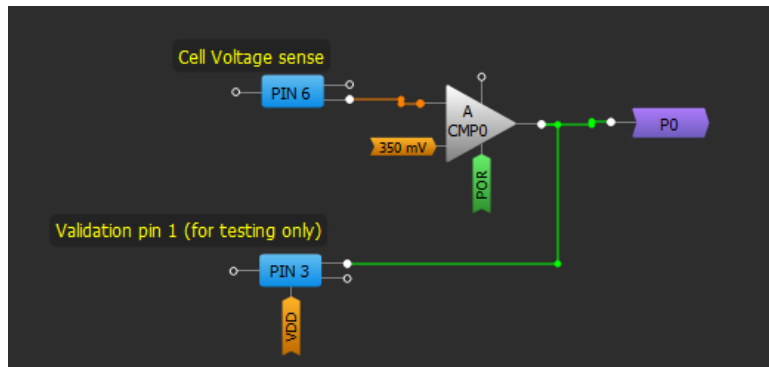

Figure 8: Voltage Sensing Block

Sensing the voltage of the PV cell to let the system know if the duty cycle needs to be incremented or decremented to track the maximum power point. Sensing the voltage helps to know the direction of the duty cycle update, and sensing the current defines the increment/decrement value. Once it hits the maximum power it continues updating the duty cycle in the same direction to perturb and observe if there is more power that can be harvested from the PV. In steady state the system will keep oscillating around the maximum power point.

3.4.1.3 Duty Cycle Updater and Stability Study:

GreenPAK in Solar Systems Maximum Power Point Trackers MPPT

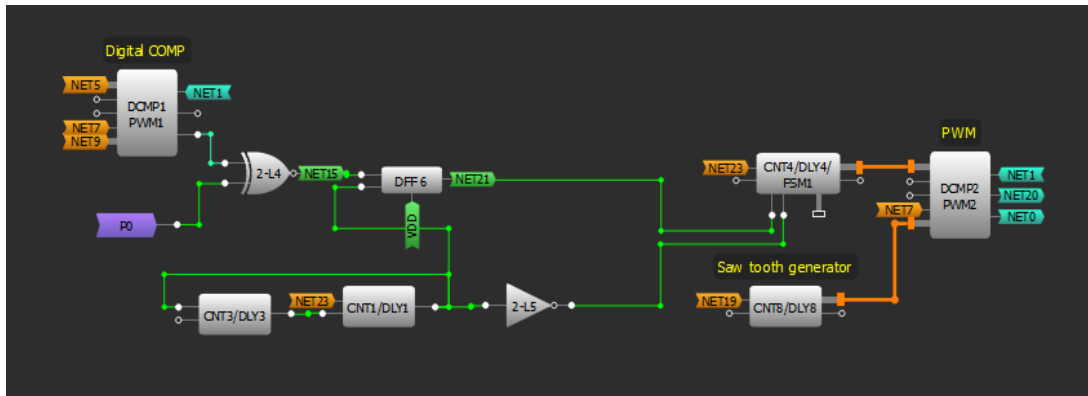

Figure 9: Duty Cycle Update Block

The system determines if the running voltage is below or higher than the MPP. The GreenPAK will determine if the running voltage is at region A or B. The XNOR output goes high in region B and low in region A based on the voltage and the Duty cycle updater which will increase or decrease the duty cycle accordingly.

The DC-DC converter requires enough time to settle down after the last duty cycle update, so the duty cycle updater must be slower than the switching frequency. Increasing the duty cycle updater frequency reduces the settling time for the system and causes instability. On the other hand, using a very slow duty cycle updater makes the system inefficient and requires a long time to track the maximum power. So it's important to get an optimum frequency that makes the system track the maximum power quickly without causing instability. The PV cells have slow variation in conditions of shadow and temperature, as these two changes in the seconds range, which is significantly slow, so updating the duty cycle in the range of few milliseconds is enough to get a stable and fast tracker. Choose the switching frequency you want for this system as this won't affect the controller but make sure that SW frequency is suitable for your components. Using higher frequency allows you to use smaller components and increases the SW loss, so find the optimum frequency for the power module you use and make sure this frequency is higher than the duty cycle updater frequency.

3.5 Hardware Connection and Testing Results

3.5.1 PV Cell Emulator

The Photovoltaic cell is a diode that generates power once photons hit it and creates a voltage difference. To mimic the same behavior of a PV cell your system for testing emulation, you simply substitute with the following:

Current source (Chroma E Load can do this)

Power diode.

Two resistors.

The following figure shows how to connect the components to emulate a PV cell and shows the output voltage of the model that emulates the actual behavior of a PV cell and how the model works. See the voltage curve at the shown three points (a,b and c) The VI curve at c simulates the exact behavior of a photovoltaic cell.

GreenPAK in Solar Systems Maximum Power Point Trackers MPPT

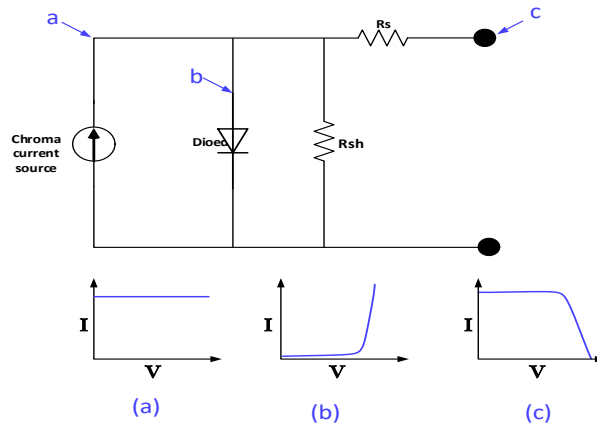

Figure 10: Photovoltaic Modelling

3.5.2 Validation Tests:

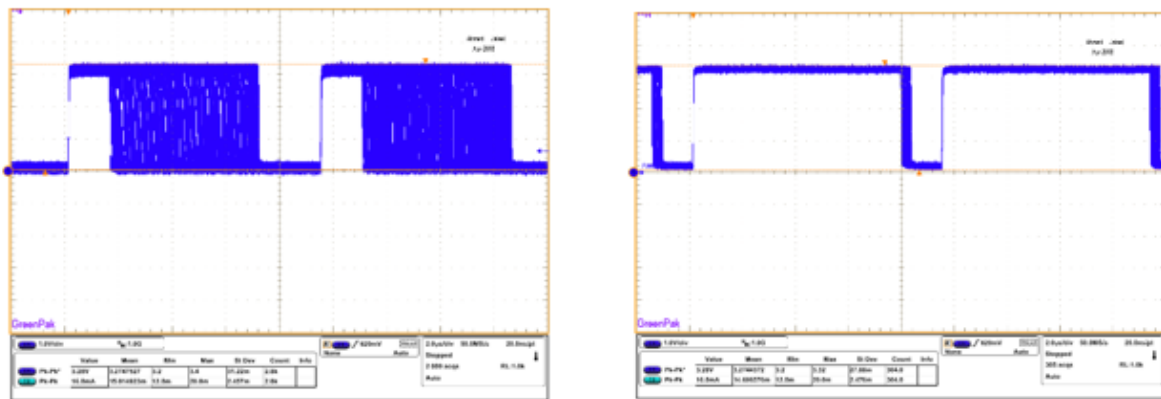

Figure 11: Duty Cycle Measurements

3.5.3 Start-up Duty Cycle Increase

The GreenPAK started from the OV point at voltage 550 mV at small duty cycle, then it increments the duty cycle that pushes the operating point toward the MPP. Once the system exceeds the MPP, it decrements the duty cycle back to track the MPP. In Figure 11 the system hovers around the MPP.

GreenPAK in Solar Systems Maximum Power Point Trackers MPPT

3.5.4 Testing the Duty Updater Frequency:

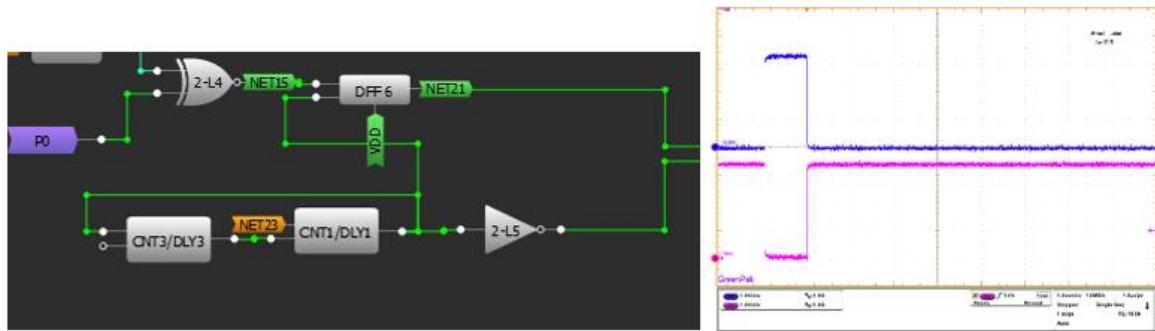

Figure 12: Duty Cycle Updater Output Testing

Figure 12 shows the signals at the duty cycle updater output. Channel 1 shows the data and channel 3 show the update/keep pin of the system.

3.5.5 Instability Example

Instability shown in the figure below while using a very fast duty cycle update, as shown the system, updates the duty cycle very fast and the voltage takes time to settle down at the OV point. Then the system realizes that it is region B so it starts increasing the duty cycle very fast but the voltage settles down at the SC point.

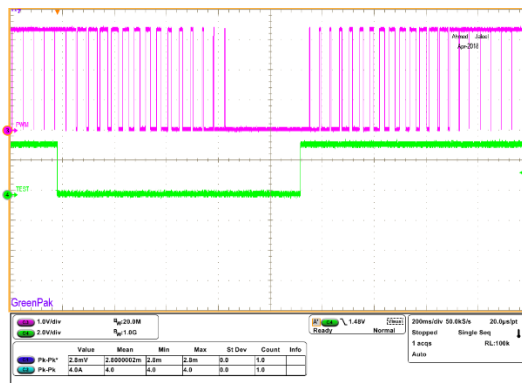

Figure 13: Instability Example

3.5.6 Power Stage Circuit

The GreenPAK will control a power Boost circuit to get the maximum power of the PV cell. The Boost converter mainly been used to step up the input voltage to a stable output voltage, but in the MPPT this is not the aim. The MPPT uses the Boost converter to act as an interface between the load and the PV by pushing the PV operating point to the maximum power point. In this circuit we are controlling the input impedance to grab the maximum power. The figure below shows the implementation of the Boost converter. This circuit is not the perfect implementation for a Boost converter. The user can create his own Boost converter or use one of the power trains in the market based on the selected PV cell power. High power applications require high current MOSFETs and larger inductors. In this case the application might require a MOSFET driver as the GreenPAK PWM won't be able to drive a very large MOSFET gate load.

GreenPAK in Solar Systems Maximum Power Point Trackers MPPT

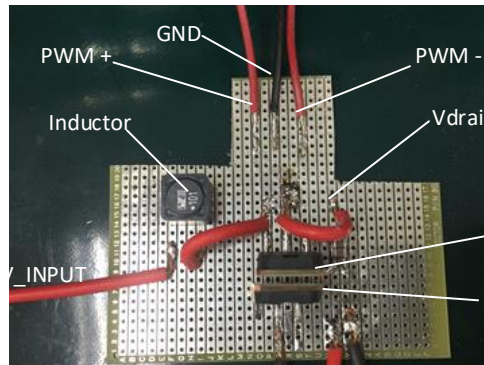

Figure 14: Power Stage (Boost Converter)

Figure 14 shows the start-up of the system. As mentioned before, it starts at the open circuit point and the GP starts to generate the Duty cycle and increase it to push the operating point toward the maximum power point and settle down oscillating around it. In Figure 15 below, we used a slow Frequency of the updater with resistive load parallel with 3x 47 μ F as an output filter. Make sure to use a switching frequency higher than duty update frequency, and make sure that you don't have any short to avoid thermal failures and redoing your work.

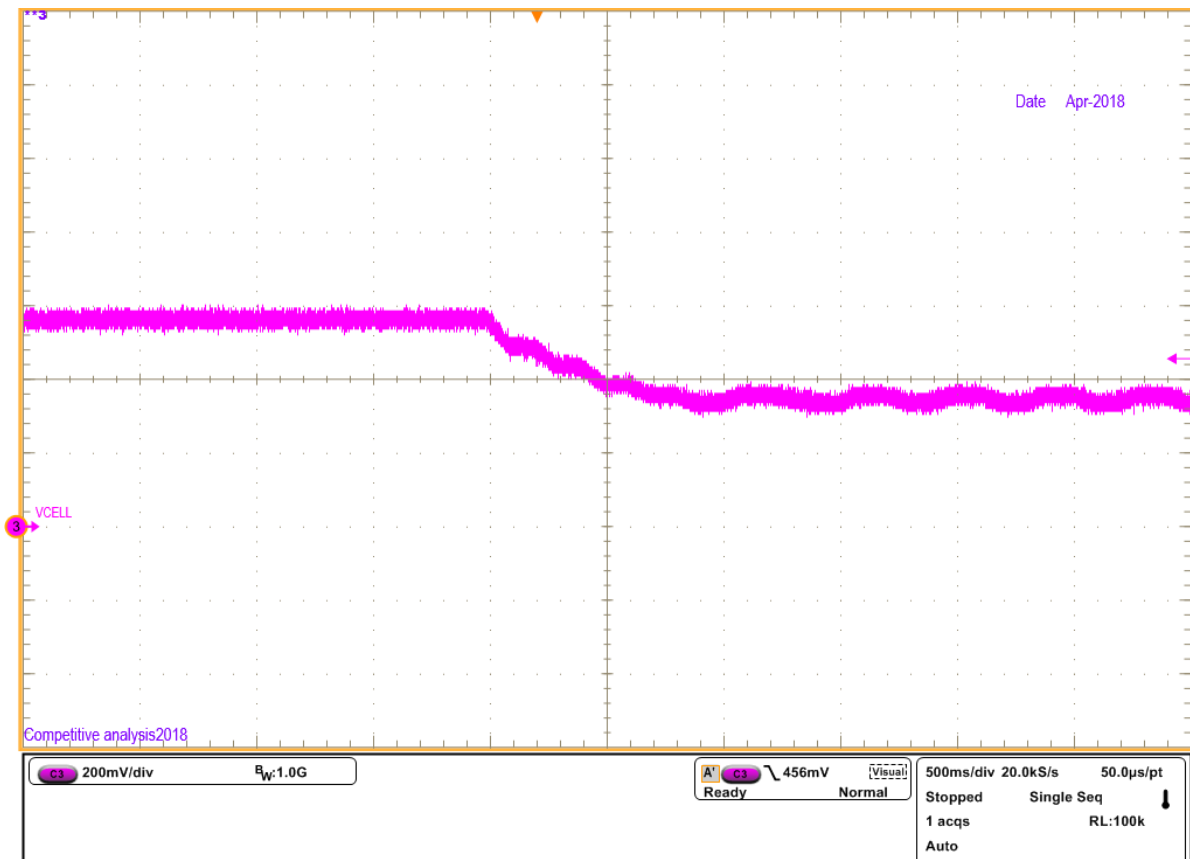

Figure 15: PC Cell Voltage with the Operation of the MPPT

GreenPAK in Solar Systems Maximum Power Point Trackers MPPT

4 Conclusions

This [GreenPAK](#) app note demonstrated the full system implementation of a Maximum Power Point Tracker using the "Perturb and Observe" topology. The MPPT will keep the photovoltaic cell working at a voltage that delivers the maximum power. A designer can connect such a [GreenPAK](#) circuit to the system and realize the benefits of very low power consumption, and significant space savings.

GreenPAK in Solar Systems Maximum Power Point Trackers MPPT

Revision History

Revision	Date	Description
1.0	03-Jul-2019	Initial Draft

IMPORTANT NOTICE AND DISCLAIMER

RENESAS ELECTRONICS CORPORATION AND ITS SUBSIDIARIES (“RENESAS”) PROVIDES TECHNICAL SPECIFICATIONS AND RELIABILITY DATA (INCLUDING DATASHEETS), DESIGN RESOURCES (INCLUDING REFERENCE DESIGNS), APPLICATION OR OTHER DESIGN ADVICE, WEB TOOLS, SAFETY INFORMATION, AND OTHER RESOURCES “AS IS” AND WITH ALL FAULTS, AND DISCLAIMS ALL WARRANTIES, EXPRESS OR IMPLIED, INCLUDING, WITHOUT LIMITATION, ANY IMPLIED WARRANTIES OF MERCHANTABILITY, FITNESS FOR A PARTICULAR PURPOSE, OR NON-INFRINGEMENT OF THIRD-PARTY INTELLECTUAL PROPERTY RIGHTS.

These resources are intended for developers who are designing with Renesas products. You are solely responsible for (1) selecting the appropriate products for your application, (2) designing, validating, and testing your application, and (3) ensuring your application meets applicable standards, and any other safety, security, or other requirements. These resources are subject to change without notice. Renesas grants you permission to use these resources only to develop an application that uses Renesas products. Other reproduction or use of these resources is strictly prohibited. No license is granted to any other Renesas intellectual property or to any third-party intellectual property. Renesas disclaims responsibility for, and you will fully indemnify Renesas and its representatives against, any claims, damages, costs, losses, or liabilities arising from your use of these resources. Renesas' products are provided only subject to Renesas' Terms and Conditions of Sale or other applicable terms agreed to in writing. No use of any Renesas resources expands or otherwise alters any applicable warranties or warranty disclaimers for these products.

(Disclaimer Rev.1.01)

Corporate Headquarters

TOYOSU FORESIA, 3-2-24 Toyosu,
Koto-ku, Tokyo 135-0061, Japan
www.renesas.com

Trademarks

Renesas and the Renesas logo are trademarks of Renesas Electronics Corporation. All trademarks and registered trademarks are the property of their respective owners.

Contact Information

For further information on a product, technology, the most up-to-date version of a document, or your nearest sales office, please visit www.renesas.com/contact-us/.