

Application Note

Solar Tracker

AN-CM-269

Abstract

This application note focuses on using a GreenPAK SLG46531V IC device to regulate an active Solar Tracker.

The application note comes complete with design files which can be found in the References section.

Contents

Abstract	1
Contents	2
Figures	2
Terms and Definitions	3
1 References	3
2 Introduction	4
3 Types of Active Trackers	4
4 Single Axis Solar Tracker with Integrated Voltage Regulator for Charging	5
5 Rotation of the Solar Panels Using a Motor Driver	5
6 Buck (step-down) Regulator	12
7 Circuit for Terminating the Process of Battery Charging	13
8 Buck Regulator – GreenPAK Logic and Calculations	14
9 Conclusion	18
Revision History	19

Figures

Figure 1: Top Level Schematic.....	4
Figure 2: Design in GreenPAK	5
Figure 3: LDR Sensor.....	6
Figure 4: Mode and LDR Inputs to ASM	6
Figure 5: ACMP Configuration Settings	7
Figure 6: ASM and LUT Configuration	8
Figure 7: Power Switch with Current Limit	9
Figure 8: Motor Limit and Overload Protection.....	9
Figure 9: Motor Driver Circuit	10
Figure 10: CNT Configuration	11
Figure 11: DFF Configuration	11
Figure 12: Low Voltage Detector Circuit.....	11
Figure 13: Wind Fault Control	12
Figure 14: Low Voltage Control.....	12
Figure 15: Buck Regulator Circuit	13
Figure 16: Electrical Schematic of a Buck Regulator	13
Figure 17: Buck Regulator Charging Logic	14
Figure 18: OSC0 Configuration	15
Figure 19: Charging Indication	15
Figure 20: Battery Charge Status LEDs are Connected on PIN18 and PIN19	15
Figure 21: Supply Schematic	16
Figure 22: Lead Acid Battery	16
Figure 23: Electrical Schematic Part 1	17
Figure 24: Electrical Schematic Part 2	17

Terms and Definitions

ASM	Asynchronous state machine
CV	Constant voltage
LDR	Light dependent resistor

1 References

For related documents and software, please visit:

[GreenPAK™ Programmable Mixed-Signal Products | Renesas](#)

Download our free [GreenPAK™ Designer](#) software [1] to open the .gp files [2] and view the proposed circuit design. Use the [GreenPAK development tools](#) [3] to freeze the design into your own customized IC in a matter of minutes. Find out more in complete library of application notes [4] featuring design examples as well as explanations of features and blocks within the GreenPAK IC.

- [1] [GreenPAK Designer Software](#), Software Download and User Guide
- [2] [AN-CM-269 Solar Tracker.gp](#), [GreenPAK Design File](#)
- [3] [GreenPAK Development Tools](#), [GreenPAK Development Tools Webpage](#)
- [4] [GreenPAK Application Notes](#), [GreenPAK Application Notes Webpage](#)

Solar Tracker

2 Introduction

Solar Trackers are a type of device that follow the movement of the sun as it traverses from east to west each day. Solar Trackers are used to keep solar collectors/solar panels oriented directly towards the sun, as the sun moves through the sky. Using Solar Trackers increases the amount of solar energy received by the solar panels and improves the energy output of the heat/electricity which is generated. Solar Trackers can increase the output of solar panels by 20-30%, which improves the economics of the solar panel project.

Solar Trackers are mostly used in ground mounted solar farms with an energy-harvesting capacity greater than 1 MW. It is more difficult to use solar trackers on residential rooftop installations. Horizontal single axis trackers are typically used for large distributed generation projects and utility scale projects.

Active trackers use motors and gear trains to direct the tracker as commanded by a controller, responding to the solar direction. Since the motors consume energy, one wants to use them only as necessary.

3 Types of Active Trackers

Single axis trackers have one degree of freedom that acts as an axis of rotation. The axis of rotation of single axis trackers is typically aligned along a true North meridian. It is possible to align them in any cardinal direction with advanced tracking algorithms. There are several common implementations of single axis trackers.

Dual axis trackers have two degrees of freedom that act as axes of rotation. These axes are typically normal to one another. The axis that is fixed with respect to the ground can be considered a primary axis. The axis that is referenced to the primary axis can be considered a secondary axis. There are several common implementations of dual axis trackers. They are classified by the orientation of their primary axes with respect to the ground.

The single axis solar tracker is realized by the **GreenPAK**, shown in [Figure 1](#).

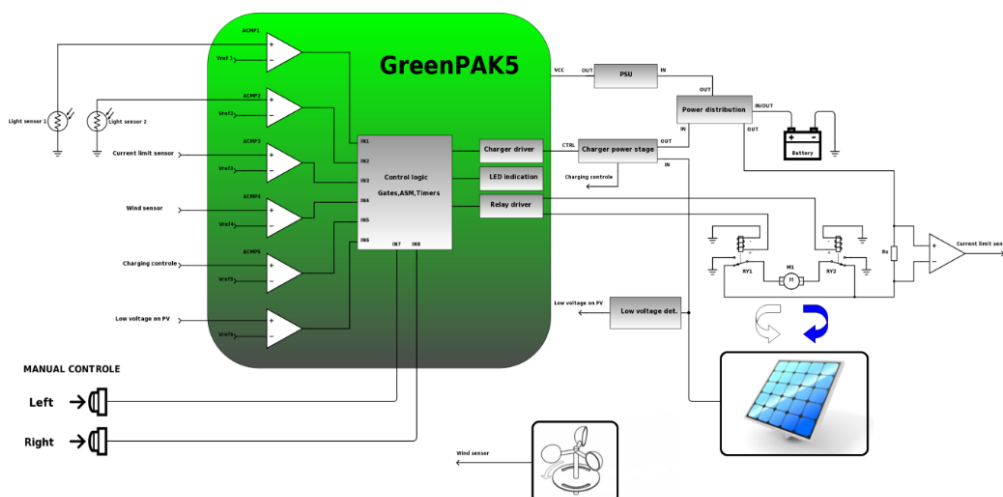

Figure 1: Top Level Schematic

4 Single Axis Solar Tracker with Integrated Voltage Regulator for Charging

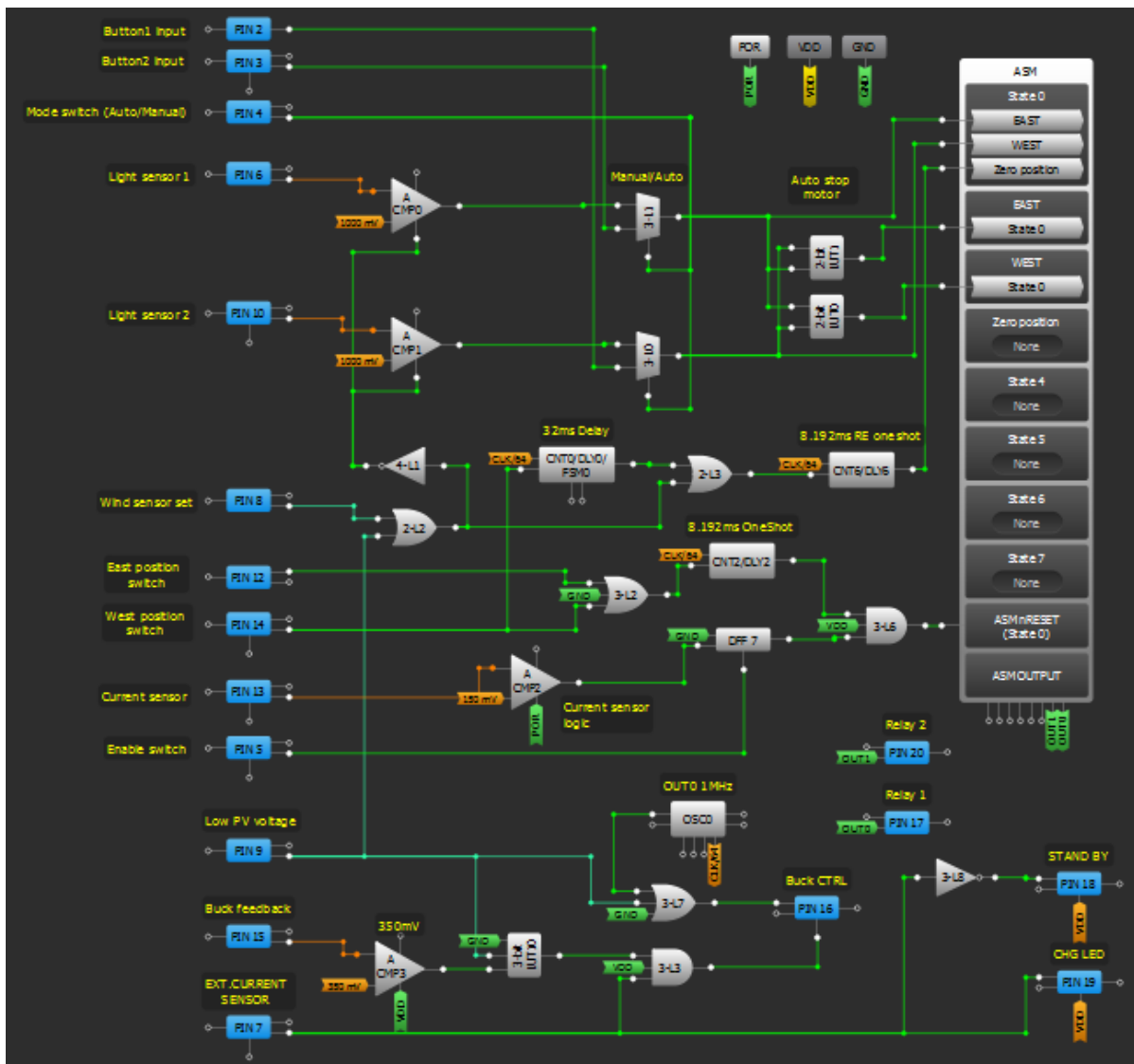

Figure 2: Design in GreenPAK

Figure 2 shows the GreenPAK SLG46531V realization of the logic for a single axis solar tracker. The schematic is segmented to compartmentalize the discrete functions.

The main purpose of this circuit is to control the motor that will turn the solar panels so that the sun rays fall directly onto the panel's surface, thereby producing the maximum possible amount of electrical energy.

5 Rotation of the Solar Panels Using a Motor Driver

Moving the motor drive can be done manually by using the test buttons 1 and 2, which directly input their signal to the GreenPAK. Alternatively, light sensors 1 and 2 generate signals on which the GreenPAK's logic arbitrates to which side the panel should turn. The mode in which the GreenPAK operates (manual or auto) depends on the state of PIN4, which can be logic 0 or logic 1. The mode is determined by an external switch.

Light sensor 1 (PIN6), Light sensor 2 (PIN10), Button 1 (PIN2) and Button 2 (PIN3) represent the inputs into the GreenPAK which are necessary to turn the panel. The outputs of the GreenPAK used

Solar Tracker

to control the motor driver are outputs from the GreenPAK's ASM. The motor driver is made by two relays which are controlled by the GreenPAK.

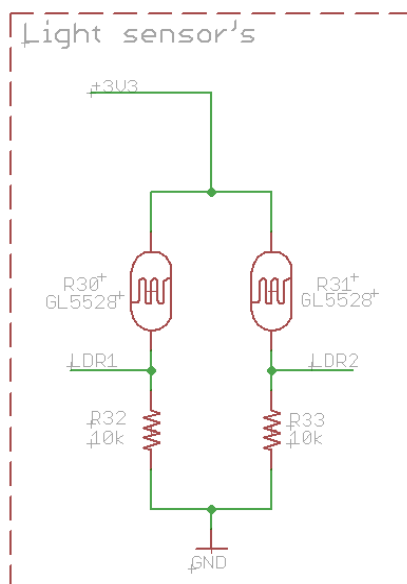

Figure 3: LDR Sensor

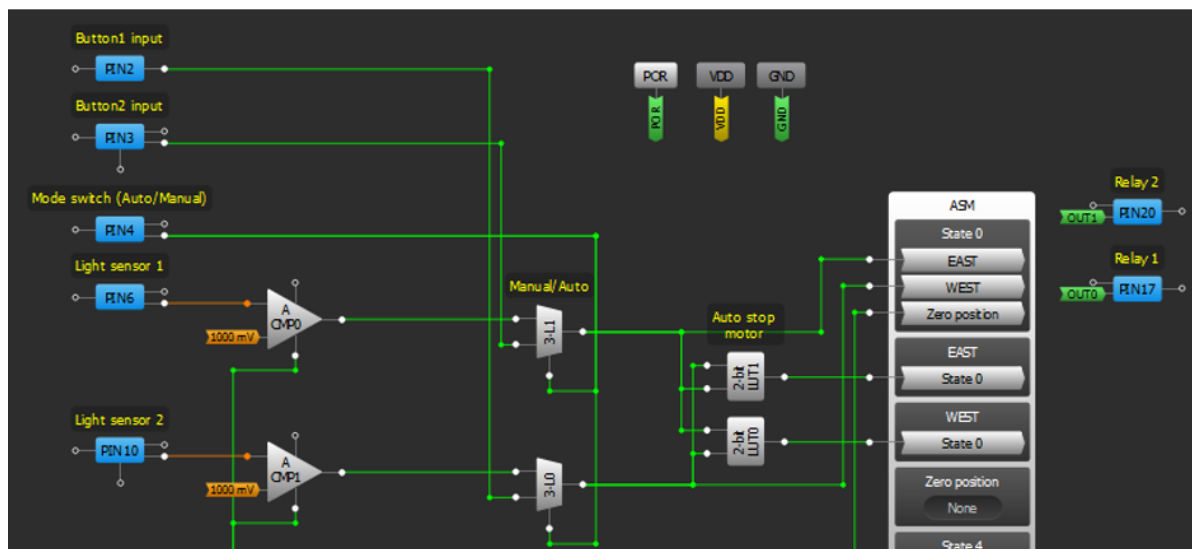

Figure 4: Mode and LDR Inputs to ASM

LDRs are used for light sensors (Figure 3). A Light Dependent Resistor, or photo-resistor, is a passive electronic component whose resistance lowers with an increase in light intensity.

Figure 4 shows the input of PIN4, which is used to select between manual or auto motor control modes. When the manual mode is selected, MUXs 3-L0 and 3-L1 pass the signals generated by the test buttons 1 and 2. Those signals trigger corresponding states in the ASM, after which the ASM generates corresponding output signals that control the motor driver. By choosing Auto mode, MUXs 3-L0 and 3-L1 pass the signals generated by ACMP0 and ACMP1, which generate signals depending upon the state of the LDR's output. There is an option to turn off the Auto mode by turning off ACMP0 and ACMP1 using the fault detection outlined further in the note. LUT0 and LUT1 are used to set the ASM to a default state. Motors will only stop moving when the ASM is in state0.

A CMP1		A CMP0	
100uA pullup on input:	Disable	100uA pullup on input:	None
Hysteresis:	25 mV	Hysteresis:	25 mV
Low bandwidth:	Enable	Low bandwidth:	Enable
IN+ gain:	Disable	IN+ gain:	Disable
Connections		Connections	
IN+ source:	PIN 10	IN+ source:	PIN 6
IN- source:	1000 mV	IN- source:	1000 mV
Information		Information	
Typical ACMP thresholds		Typical ACMP thresholds	
V_IH (mV)	V_IL (mV)	V_IH (mV)	V_IL (mV)
1013	988	1013	988
ACMP start time (Summary)		ACMP start time (Summary)	

Figure 5: ACMP Configuration Settings

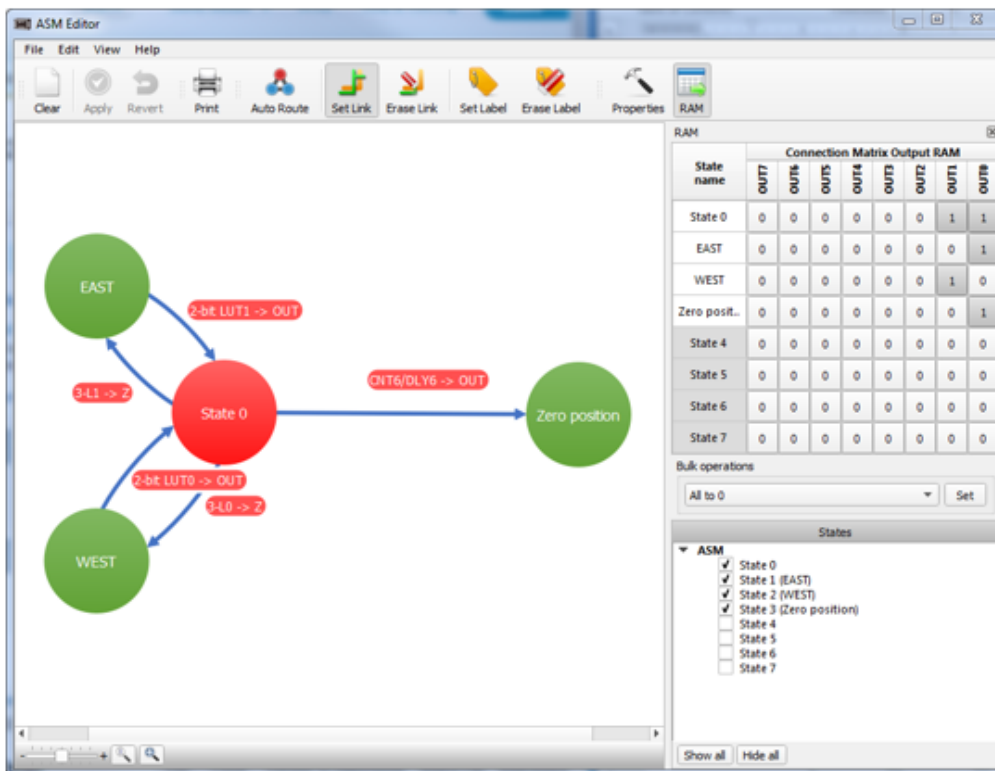

2-bit LUT0			2-bit LUT1		
IN1	IN0	OUT	IN1	IN0	OUT
0	0	1	0	0	1
0	1	0	0	1	1
1	0	1	1	0	0
1	1	1	1	1	1

Figure 6: ASM and LUT Configuration

Although 2-bit LUT0 and 2-bit LUT1 can trigger the ASM to change to State0, it is also possible to reset the ASM by using a HIGH (logical 1) signal at nRESET IN of the ASM. This stops the motor when the panel moves to one of the end positions (limit switches). When position switch is pressed the ASM will reset and go to state 0. The stopping in both cases (east and west end positions) is implemented in the same way. This system also has the ability to prevent motor overload. In case the motor that moves the solar panel gets stuck for some reason, IC2 (SLG59H1005, see Figure 7) will detect that the current passing through the motor has passed the set current limit and it will send a signal to GreenPAK that will turn the ASM off, and thus the motor will be turned off as well.

Solar Tracker

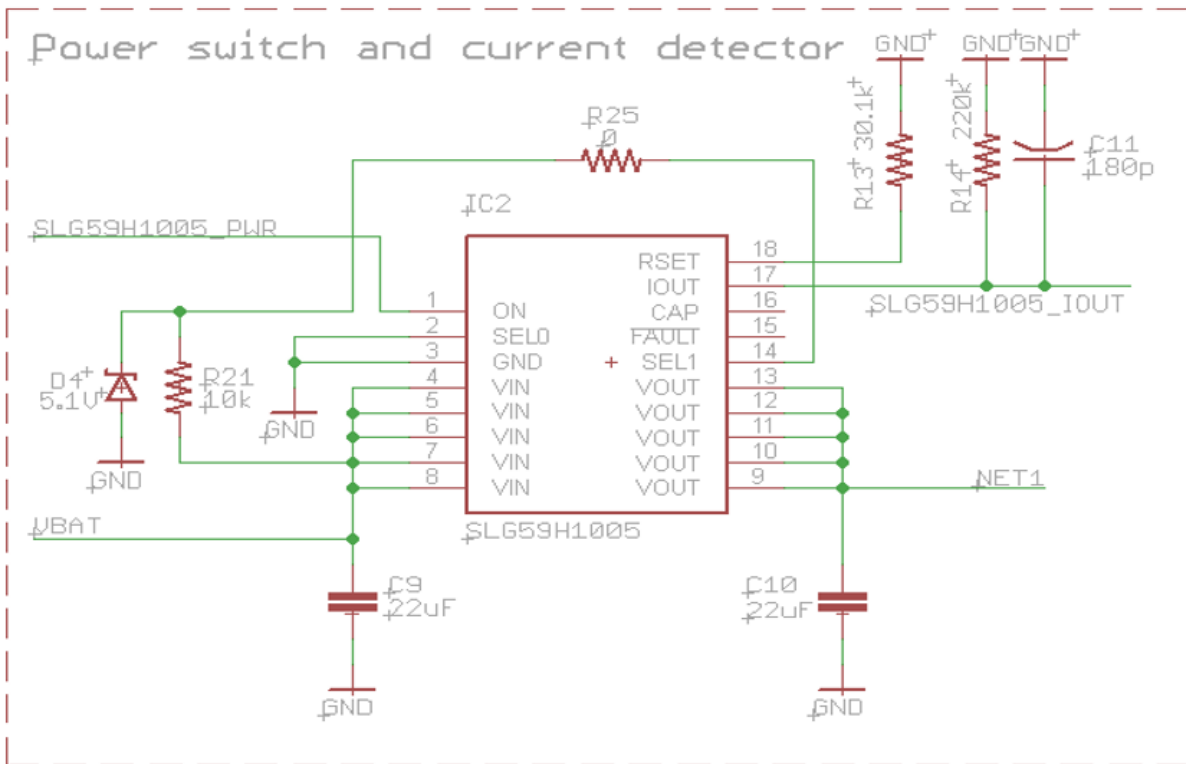

Figure 7: Power Switch with Current Limit

Running the system again is possible by pressing the switch that is connected to PIN5. Figure 8 shows the logic of motor stopping in end positions and motor overload prevention.

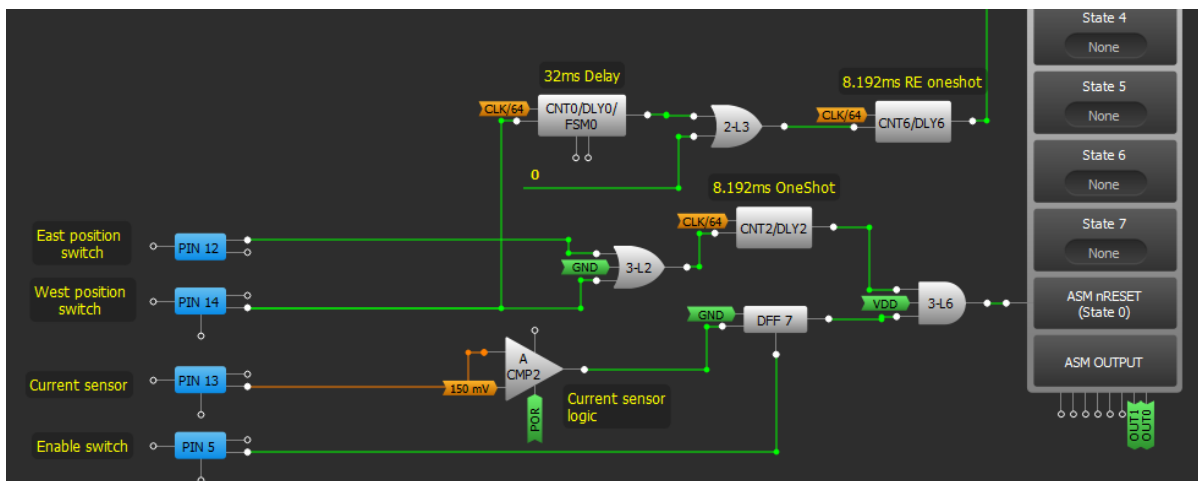

Figure 8: Motor Limit and Overload Protection

In order for the ASM to function, nReset pin has to be HIGH . When the system is turned on, initial states DFF7 and CNT2/DLY3 are set as logic 1 (HIGH). CNT2/DLY2 is also set as OneShot. It's clear from looking at the image that all inputs of AND logic circuit are logic 1, and as a result we have logic 1 on ASM nReset. Let's assume that the solar panel is somewhere on the way between east and west limit switches and that it's moving towards west limit switch. When it triggers west limit switch, the change from LOW to HIGH will happen on pin 14. That change will be transferred over OR logic circuit to OneShot block CNT2/DLY2 input which will generate a change from HIGH to LOW and reset the ASM. ASM will then switch to State 0 and the motor will stop. We can see that block DLY0 is also connected to PIN 14.

32 ms after the change from LOW to HIGH on PIN14 happened, DLY0 will activate OneShot block CNT6/DLY6, which will generate a signal and switch ASM to State Zero position. The State Zero

Solar Tracker

position has the command for the panel to turn towards east, that is, to return to starting position and wait for sunrise. When the solar panel triggers East limit switch, it will also trigger OneShot block CNT2/DLY2 through OR logic circuit. OneShot block CNT2/DLY2 will generate a signal for resetting ASM and it will set ASM to State 0 and the motor will stop. In case the motor gets stuck during its operation it will draw more current. Exceeding of the limit for current through the motor will be detected by IC2 that will generate a signal to PIN13 and ACMP2. That signal will change the state of DFF7. DFF7 output will be LOW and it will disable ASM, and thus the motor as well.

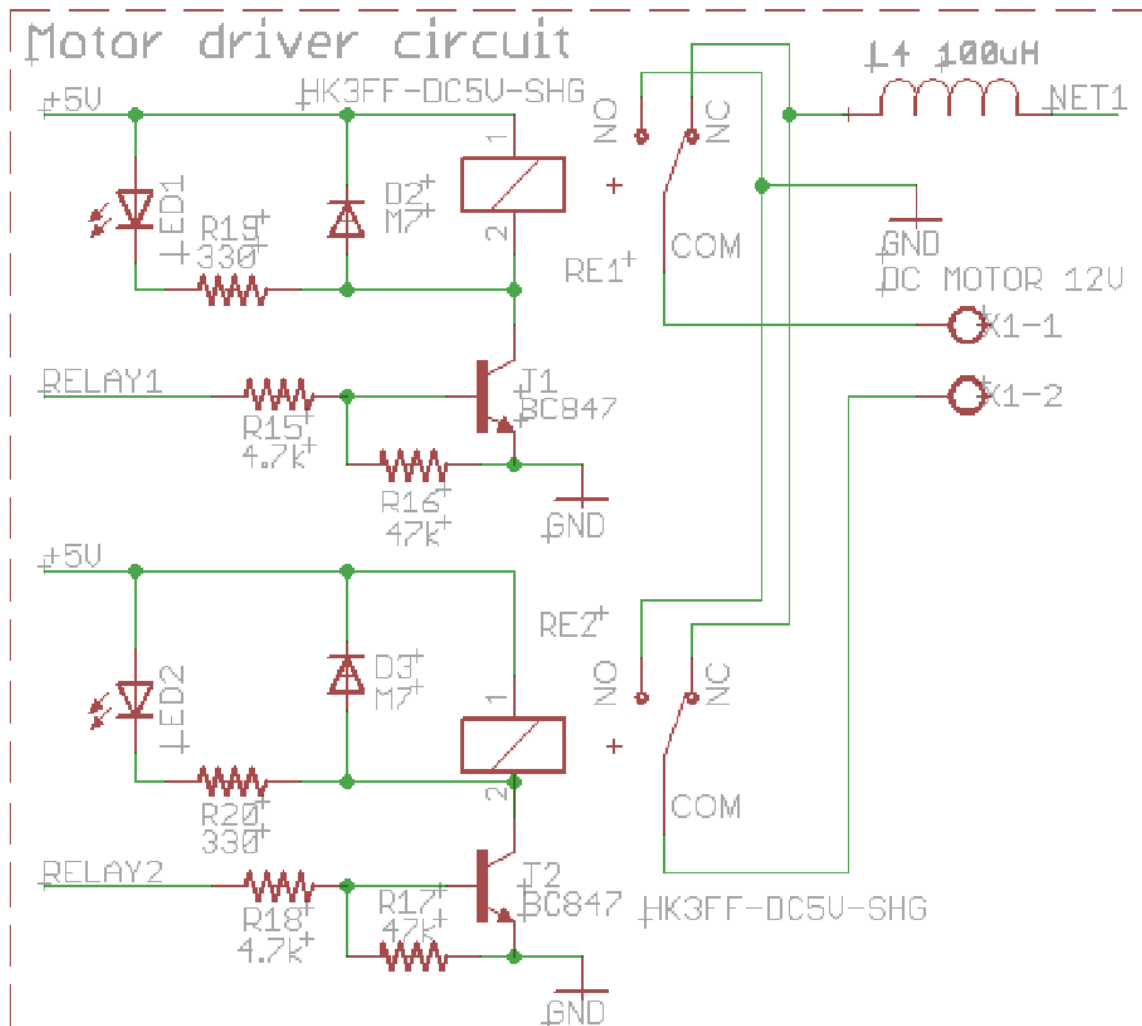

Figure 9: Motor Driver Circuit

ACMP2, CNT2/DLY2, DFF7 and 3-L6 are used to implement the reset logic of the ASM. CNT2/DLY2 is set to work in one shot mode to generate only one pulse, no matter how long the voltage of logic unit that is generated by external circuit is presented on the input of DLYIN.

Output IOUT of circuit SLG59H1005 is externally connected to PIN13 of the GreenPAK. Depending on the current through the motor, that is, through SLG59H1005 on IOUT, we'll have a voltage equivalent to current according to the equation:

$$V_{IOUT} = R_{IOUT} * I_{OUT}$$

Where R_{IOUT} is resistor between GND and pin IOUT of the SLG59H1005 circuit.

In addition to using this circuit for measuring the current through the motor, the design also implements a power controller for the motor. If the voltage on a panel is below a certain level the motor's power supply is lost.

Solar Tracker

When the sun starts setting and the panel has come to its end position by following the sun, the voltage on the panel starts to decline and the low voltage circuit, shown in Figure 12, will detect when the voltage drops below a certain level and will generate an output signal which will lead to PIN9 of GreenPAK. This signal is used to return the panel to the default position (east end).

<div style="border: 1px solid black; padding: 5px;"> <p style="text-align: center; background-color: #90EE90; margin: -5px -5px 5px -5px;">3-bit LUT5/8-bit CNT2/DLY2</p> <p>Type: CNT/DLY</p> <p>Mode: One shot</p> <p>Counter data: 255 <small>(Range: 1 - 255)</small></p> <p>Pulse width (typical): 8.192 ms Formula</p> <p>Edge select: Rising</p> <p>Output polarity: Inverted (nOUT)</p> <p>Q mode: None</p> </div> <p style="text-align: center;">Figure 10: CNT Configuration</p>	<div style="border: 1px solid black; padding: 5px;"> <p style="text-align: center; background-color: #90EE90; margin: -5px -5px 5px -5px;">3-bit LUT4/DFF/LATCH7</p> <p>Type: DFF / LATCH</p> <p>Mode: DFF</p> <p>nSET/nRESET option: nRESET</p> <p>Initial polarity: High</p> <p>Q output polarity: Inverted (nQ)</p> </div> <p style="text-align: center;">Figure 11: DFF Configuration</p>
--	--

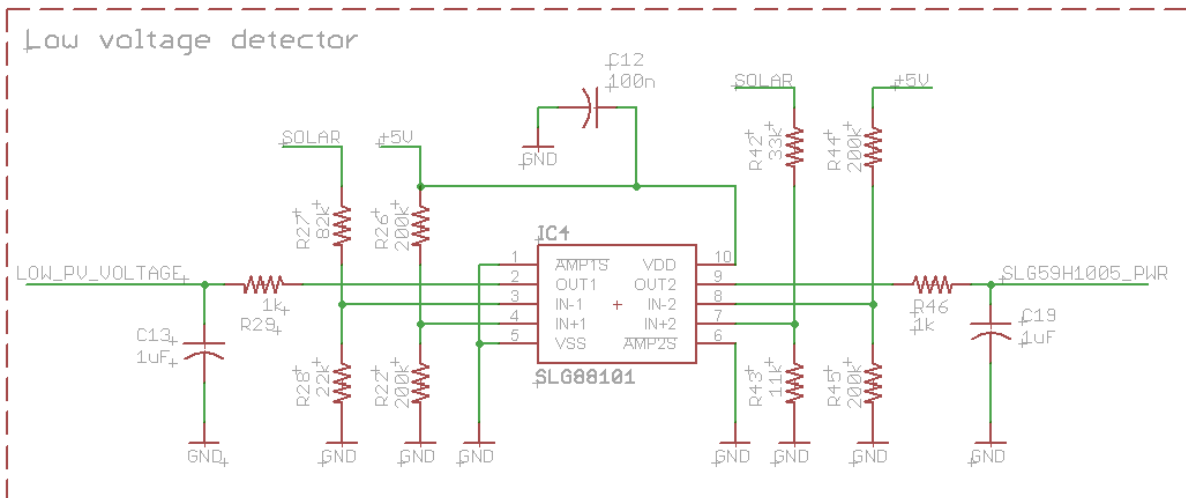

Figure 12: Low Voltage Detector Circuit

IC4 is low power dual amplifier, where AMP1 detecting low voltage, AMP2 cut off power for motor. The voltage threshold in “AMP1” is higher than the voltage threshold in “AMP2” because the motor needs power to move the panel to the default position before SLG59H1005 cuts the motor's power supply entirely. Also, when the voltage on the panel is below certain level, auto control of the motor moving the panel is disabled. This is achieved by turning off ACMP0 and ACMP1, which will then not function regardless the sensor state.

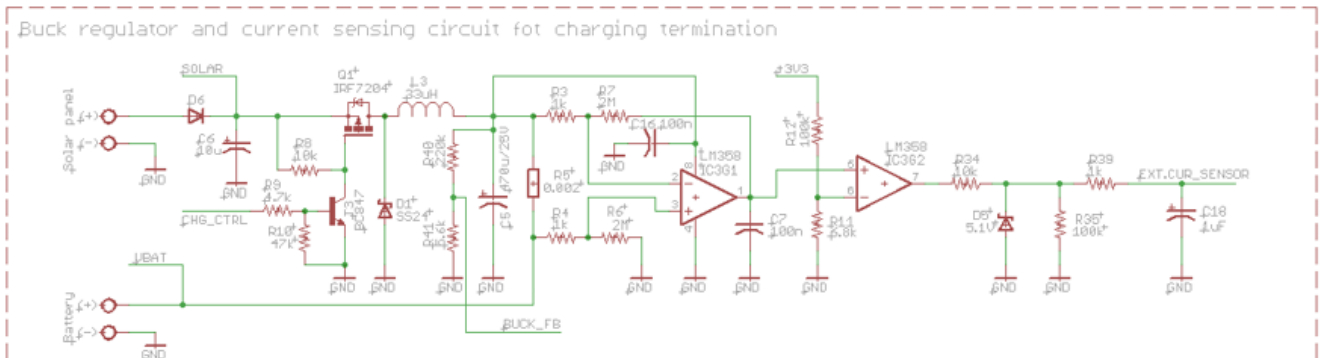

Figure 15: Buck Regulator Circuit

Figure 16 shows an electrical schematic of a buck regulator with circuitry for measuring the charging current. The measured charging current determines when to terminate the process of charging the battery. Figure 18 highlights the logic of Buck regulator.

7 Circuit for Terminating the Process of Battery Charging

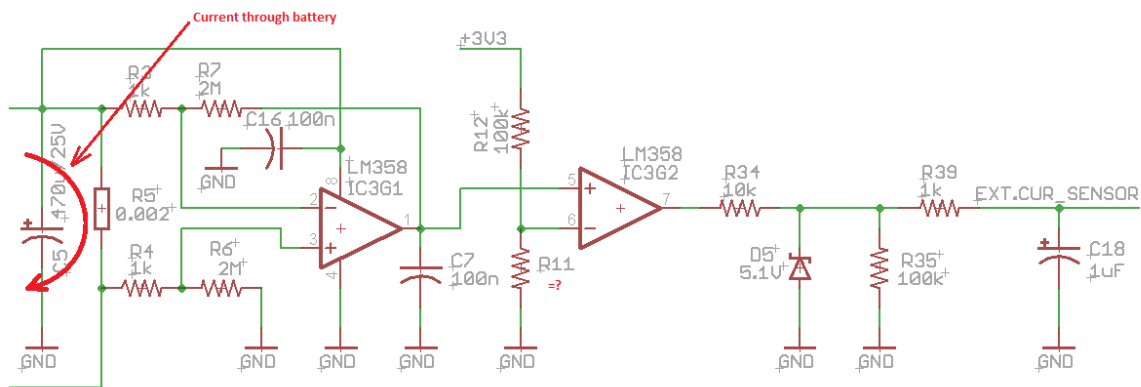

Figure 16: Electrical Schematic of a Buck Regulator

The circuit for terminating the charge process consists of two stages that are realized with LM358 operational amplifiers. The first stage of this circuit consists of sensing the current through resistor R5 (at any given time the current through R5 is equal to current of battery charge). The first stage then converts the voltage that leads to the input of the voltage comparator at the beginning of the second stage. Resistors R11 and R12 define the current at which the process of charging is terminated. Amplifying the first stage is $G=2000$. If the current falls below 500 mA the charging process is finished. R12 is set at 100k and R11 is calculated. The following equations are also calculated:

$$V_{R5} = R5 * I_{BAT} = 0.002\Omega * 0.5 A = 0.001 V, \text{ VR5 - voltage on R5, IBAT-current through battery}$$

$$V_O = G * V_{R5} = 2000 * 0.001 * 2000 V = 2 V, \text{ output voltage of the first stage}$$

$$R_{11} = \frac{V_O}{\frac{3.3-V_O}{R_{12}}} = 153.84 k\Omega$$

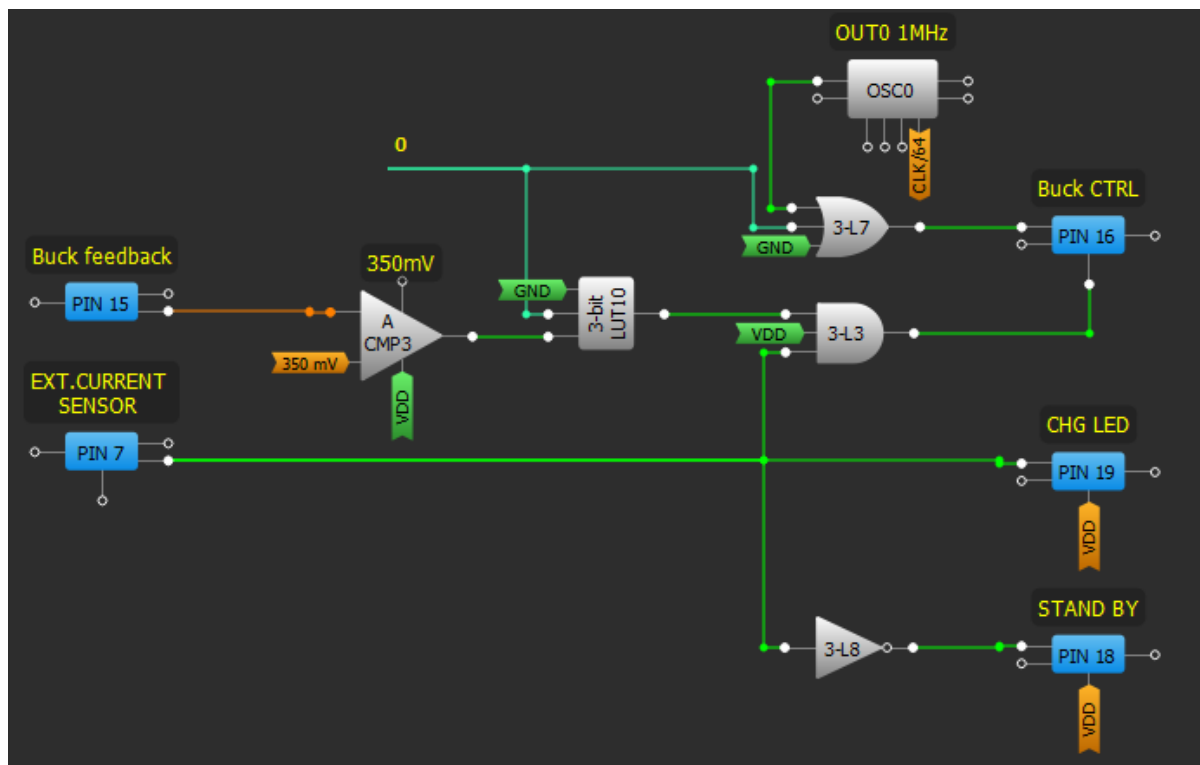

Figure 17: Buck Regulator Charging Logic

8 Buck Regulator – GreenPAK Logic and Calculations

If the circuit output for terminating the charging process (PIN7) is HIGH, the battery needs to be charged. PIN16 directly controls the top gate MOSFET in the buck regulator. Pin 16 is arbitrated by the buck feedback and external current sensor. Using OSC0 as the clock ensures consistency for the power stage, duty cycle and frequency. Using these two parameters and other needed parameters the calculated value of the components for the buck power stage are shown:

$D = 50\%$, duty cycle

$f_s = 1\text{MHz}$, switching frequency

$I_{OUT(max)} = 3\text{A}$, output current

$V_{OUT} = 14.0\text{V}$, desired output voltage

$\eta = 85\%$, efficiency of the converter

$\Delta V_{OUT} = 500\text{mV}$, desired output voltage ripple

$V_{IN(max)} = \frac{V_{OUT}}{D \cdot \eta} = 32,94\text{V}$, max. Input voltage

$\Delta I_L = (0.2 \text{ to } 0.4) * I_{OUT(max)} = 0.2 * 3\text{A} = 0.6\text{A}$, inductor ripple current

$L_{min} = \frac{V_{OUT} * (V_{IN(max)} - V_{OUT})}{\Delta I_L * f_s * V_{IN(max)}} = 13,41\mu\text{H}$, min. inductor value

$I_{SW(max)} = I_{OUT(max)} + \frac{\Delta I_L}{2} = 3,3\text{A}$, max. switching current

$C_{OUT(min)} = \frac{\Delta I_L}{8 * \Delta V_{OUT} * f_s} \approx 1\mu\text{F}$, min.output capacitance

$I_F = I_{OUT(max)} * (1 - D) = 1,5\text{A}$, diode forward current

$P_D = I_F * V_F = 0.75\text{W}$, diode power dissipation

Solar Tracker

Based on calculated parameters for buck power stage it is possible to choose components, coils L, MOSFET, the output capacitor, and diodes.

OSC0	
Control pin mode:	Force on
OSC Power Mode:	Force Power On
Clock selector:	OSC
EXT CLK Pin selector:	PIN 20
Fast start-up:	Disable
RC OSC Frequency:	2 MHz
'CLK' predivider by:	1
'OUT0' second divider by:	2
'OUT1' second divider by:	1
Information	
Frequency	
Clock output configuration:	
RC OSC Output	Value
CLK /4	RC OSC Freq. /4
CLK /12	RC OSC Freq. /12
CLK /24	RC OSC Freq. /24
CLK /64	RC OSC Freq. /64
OUT0	RC OSC Freq. /2
OUT1	RC OSC Freq.

Figure 18: OSC0 Configuration

Based on calculated parameters for buck power stage it is possible to choose components, coils L, MOSFET, the output capacitor, and diodes.

3-bit LUT10			
IN2	IN1	IN0	OUT
0	0	0	1
0	0	1	1
0	1	0	0
0	1	1	1
1	0	0	1
1	0	1	1
1	1	0	0
1	1	1	1

Figure 19: Charging Indication

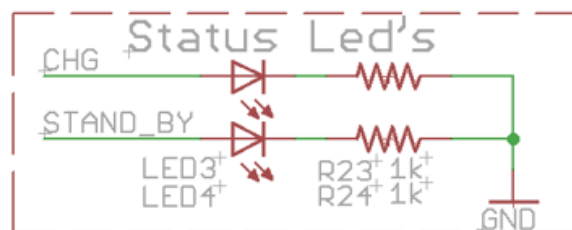

Figure 20: Battery Charge Status LEDs are Connected on PIN18 and PIN19

Battery charge status LEDs are connected on PIN18 and PIN19.

Solar Tracker

Electronic circuits used for realization of this assembly nominally require a supply of +5 and 3.3 V. Figure 21 is the schematic of the supply circuit.

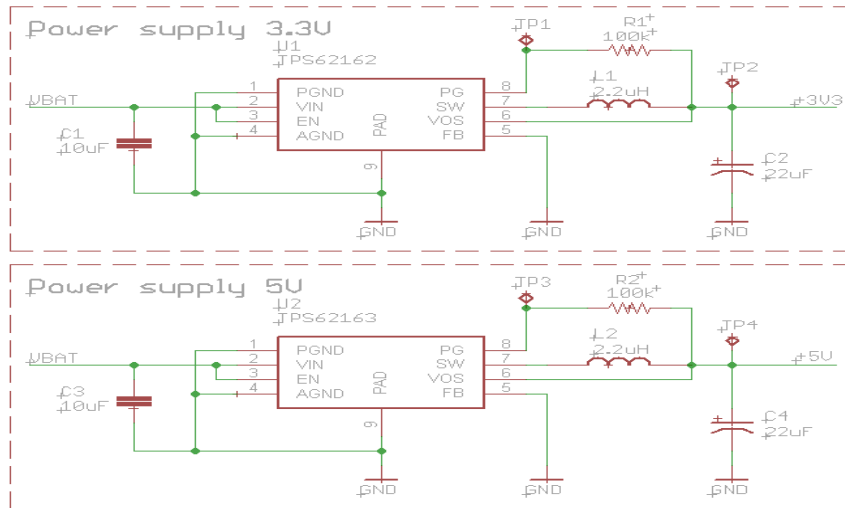

Figure 21: Supply Schematic

This system is adapted for charging the wet cell batteries that are more resistant to overcharge and don't require a specific way of charging. By contrast, lead acid batteries would not be able to function with this charging configuration.

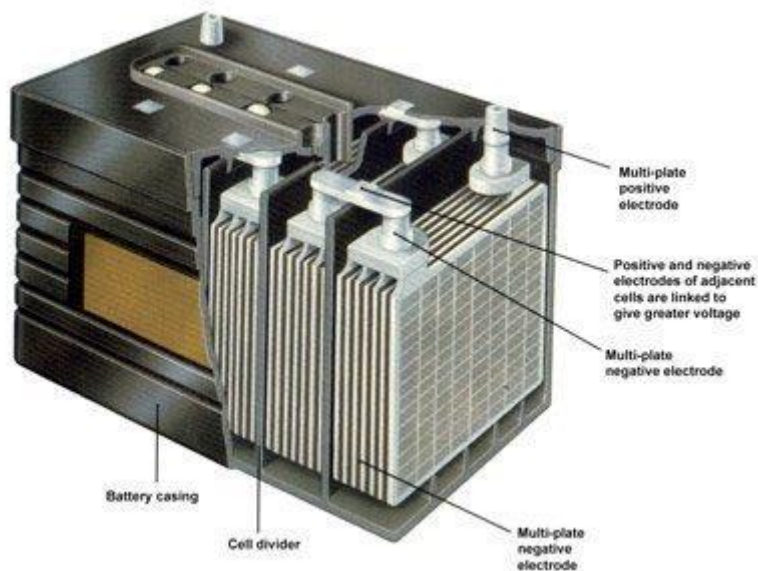

Figure 22: Lead Acid Battery

Solar Tracker

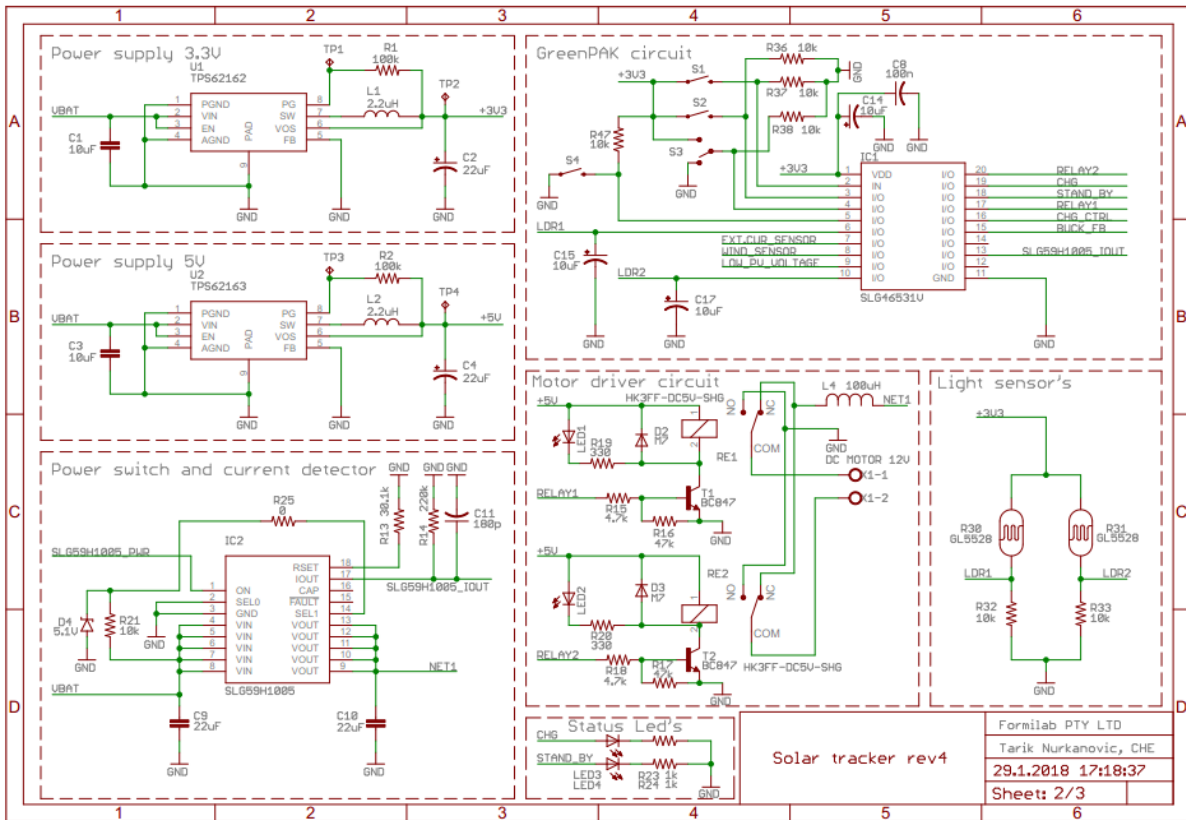

Figure 23: Electrical Schematic Part 1

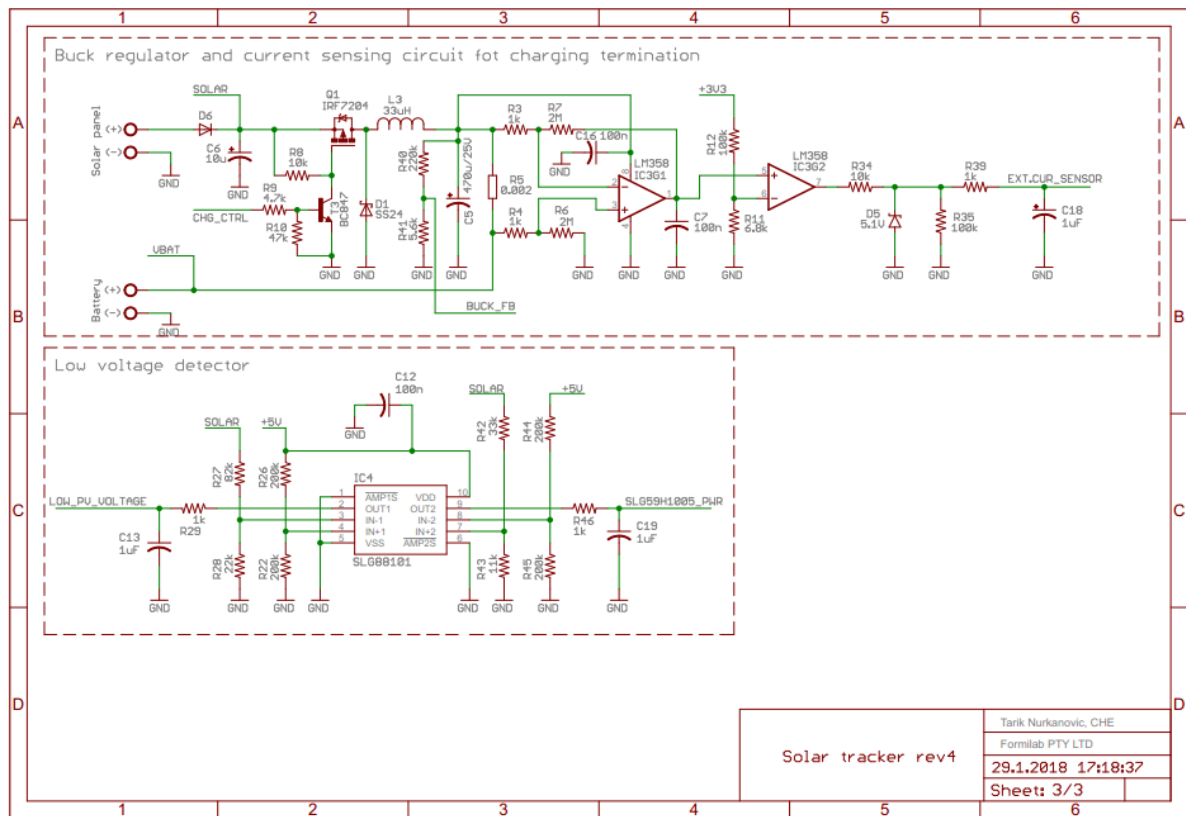

Figure 24: Electrical Schematic Part 2

9 Conclusion

The proposed design and implementation show that the single axis solar tracker with voltage regulator can be realized using the SLG46531V [GreenPAK](#). The single axis solar tracker itself is a combination of analog and digital techniques, which means that a significant number of analog and digital integrated circuits are needed for the assembly. By using [GreenPAK](#) it is possible to significantly reduce that number of circuits and thus reduce the size and cost of the product. Reducing the number of mentioned circuits significantly reduces the chance for any errors which results in a more reliable system, all thanks to [GreenPAK](#) technology.

Solar Tracker

Revision History

Revision	Date	Description
1.0	25-Jan-2019	Initial Version

IMPORTANT NOTICE AND DISCLAIMER

RENESAS ELECTRONICS CORPORATION AND ITS SUBSIDIARIES (“RENESAS”) PROVIDES TECHNICAL SPECIFICATIONS AND RELIABILITY DATA (INCLUDING DATASHEETS), DESIGN RESOURCES (INCLUDING REFERENCE DESIGNS), APPLICATION OR OTHER DESIGN ADVICE, WEB TOOLS, SAFETY INFORMATION, AND OTHER RESOURCES “AS IS” AND WITH ALL FAULTS, AND DISCLAIMS ALL WARRANTIES, EXPRESS OR IMPLIED, INCLUDING, WITHOUT LIMITATION, ANY IMPLIED WARRANTIES OF MERCHANTABILITY, FITNESS FOR A PARTICULAR PURPOSE, OR NON-INFRINGEMENT OF THIRD-PARTY INTELLECTUAL PROPERTY RIGHTS.

These resources are intended for developers who are designing with Renesas products. You are solely responsible for (1) selecting the appropriate products for your application, (2) designing, validating, and testing your application, and (3) ensuring your application meets applicable standards, and any other safety, security, or other requirements. These resources are subject to change without notice. Renesas grants you permission to use these resources only to develop an application that uses Renesas products. Other reproduction or use of these resources is strictly prohibited. No license is granted to any other Renesas intellectual property or to any third-party intellectual property. Renesas disclaims responsibility for, and you will fully indemnify Renesas and its representatives against, any claims, damages, costs, losses, or liabilities arising from your use of these resources. Renesas' products are provided only subject to Renesas' Terms and Conditions of Sale or other applicable terms agreed to in writing. No use of any Renesas resources expands or otherwise alters any applicable warranties or warranty disclaimers for these products.

(Disclaimer Rev.1.01)

Corporate Headquarters

TOYOSU FORESIA, 3-2-24 Toyosu,
Koto-ku, Tokyo 135-0061, Japan
www.renesas.com

Trademarks

Renesas and the Renesas logo are trademarks of Renesas Electronics Corporation. All trademarks and registered trademarks are the property of their respective owners.

Contact Information

For further information on a product, technology, the most up-to-date version of a document, or your nearest sales office, please visit www.renesas.com/contact-us/.