

AN-1188 Power Line Communication to Send Digital Data Using GreenPAK™

In this application note, digital data is transferred over AC lines using two [GreenPAK SLG46620V](#) IC's, along with two [KQ-330F power line communication modems](#). The basic objectives of the application note are:

- To enable a power distribution company to gain control over consumer electrical appliances.
- To allow the consumer to check the power consumption and power status of various appliances via the internet. We used a test webserver for this purpose.

In this application note, 8 appliances are controlled using one SLG46620V and their power status (whether the appliance is ON or OFF) is sent back using another SLG46620V. The data communication is carried out over the KQ-330F.

Hardware Schematic

The hardware schematic is shown below:

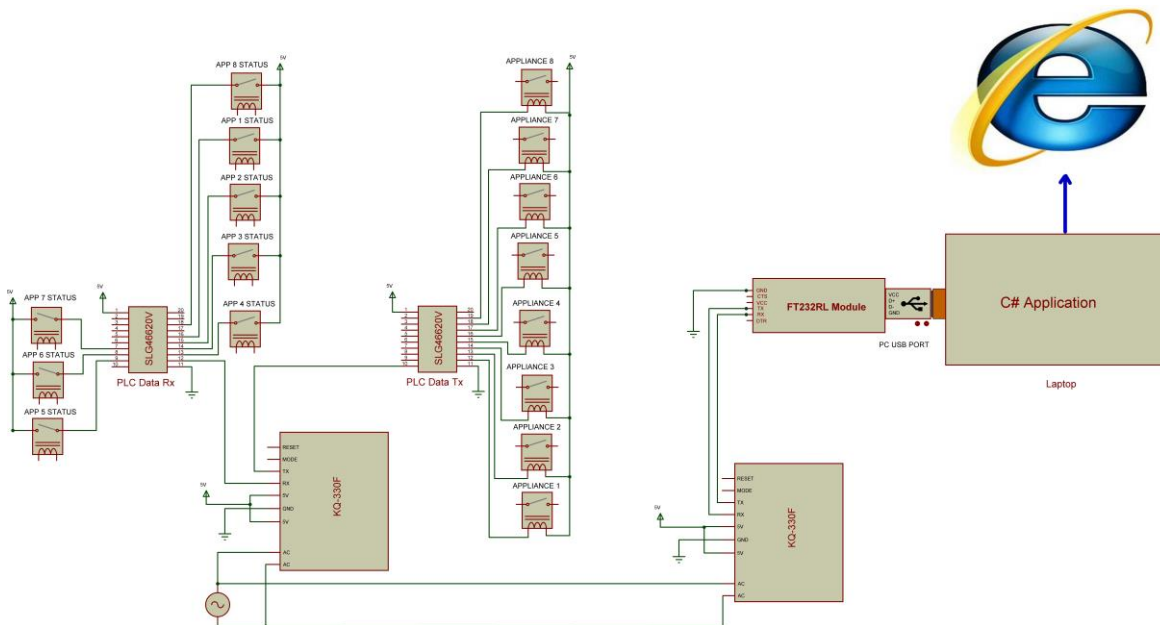

Figure 1. Hardware Schematic

As you can see in Figure 1, the status of all 8 appliances is fed to SLG46620V pins after passing through corresponding relays. The contact of the relay is fed with a 5v signal, which is the same voltage supplied as VDD. When the device is powered off by the consumer or by the Power Distribution Company, a low appears on the SLG46620V's Digital Input pin for the corresponding appliance. This data is sent to the KQ-330F, which converts the data to a suitable baud rate for the KQ-330F.

Similarly, the data from the Power Distribution Company is received serially by SLG46620V from KQ-330F. The data is then distributed to up to 8 corresponding appliances, which are operated using 5v opto-isolated relays.

It must be noted that power line communication is prone to data corruption. To avoid this, the wires used on the DC side should be very short.

KQ-330F power line communication Modem

The KQ-330F is a single 9-pin small size high performance data transceiver module. It works with 220V AC, and operates at a serial baudrate of 9600bps.



Figure 2. KQ-330F Module

Figure 2 shows the module pinout. The connections of two KQ-330F used in the app note are shown in Table 1.

Sr. No.	Pin No	Connections on Consumer Side	Connections on Power Distribution Company Side
1	1	Not Used	Not Used
2	2	Not Used	Not Used
3	3	PIN 10 of SLG46620V (PLC Data Receiver)	Rx of COM port module
4	4	PIN 12 of SLG46620V (PLC Data Sender)	Tx of COM port module
5	5	5V	5V
6	6	Ground	Ground
7	7	5V	5V
8	8	AC (Live or Neutral)	AC (Live or Neutral)
9	9	AC (Live or Neutral)	AC (Live or Neutral)

Table 1. KQ-330F Hardware Connections

GreenPAK Design code

There are two SLG46620V IC's used in the design. One is for sending data to the KQ-330F and the other for receiving data from KQ-330F.

PLC Data Sender

This design reuses the SLG46620V design from [AN-1156 Fall Detection Alert Using GreenPAK](#).

Rather than rewriting the design explanation, please refer to AN-1156.

During normal operation of the 4-bit DFF counter, it counts from 0000 to 1001. Since we have to process 10 data bits (start bit, 8 status bits, stop bit), after reaching the 10th state (1001), we need to reset the counter to its initial state (0000) in the next cycle. The AND gate (3-L3) resets the 4-bit counter before going to 11th state of the counter where Q4 and Q2 are high.

Sr. No.	Q4Q3Q2Q1	Decimal	Data
0	0000	0	Start Bit (0)
2	0001	1	Appliance 1 Status
3	0010	2	Appliance 2 Status
4	0011	3	Appliance 3 Status
5	0100	4	Appliance 4 Status
6	0101	5	Appliance 5 Status
7	0110	6	Appliance 6 Status
8	0111	7	Appliance 7 Status
9	1000	8	Appliance 8 Status
10	1001	9	Stop Bit (1)

Table 2. Counter outputs and Button status bits

1. Concatenating Start bit, 8 digital status bits, and Stop bit

In this section, the 10 bits (start bit, 8 button status and stop bit) will be routed to PIN 12 one at a time. The structure of an example data stream is shown below.

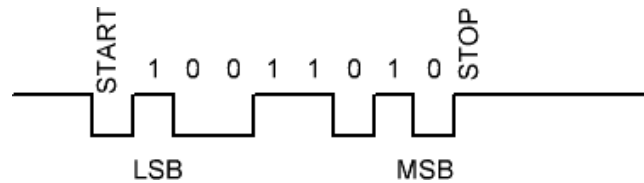

Figure 3. Example Serial Data stream

Figure 3 shows that the output on PIN 12 should be typically HIGH. When we are ready to send data, we send a START bit (0), followed by the 8 status bits and a STOP bit (1) at the end of the packet.

2. Basic Building Block of Data stream

In the GreenPAK design, we used LUTs to concatenate the 10 packet bits and output them on Pin12.

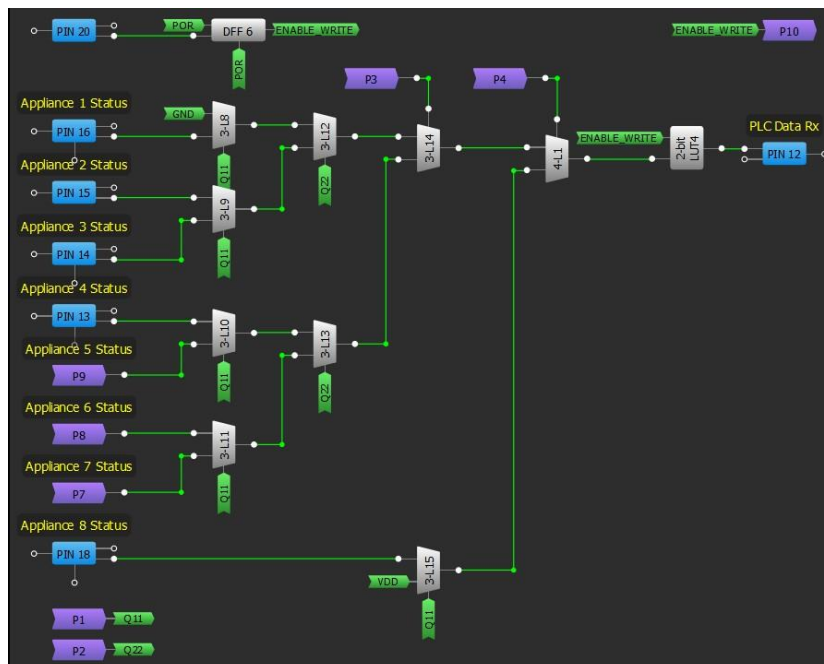

Figure 4. Concatenation of Data Stream

When ENABLE_WRITE is LOW, Pin12 outputs HIGH. When ENABLE_WRITE goes HIGH, the multiplexers are used to sequentially pass the packet bits to Pin12.

Sr. No.	Serial Data	SLG46620V Mapped Pin
1	Device 1 status	12
2	Device 2 status	13 </td
3	Device 3 status	14
4	Device 4 status	15
5	Device 5 status	16
6	Device 6 status	17
7	Device 7 status	18
8	Device 8 status	19

Table 3. Serial Data from KQ-330F mapped on SLG46620V Pins

Data at output pins

The serial data is converted into parallel data, and is output on pins 12:19 via the SPI Parallel Output Block. Each output pin can be used to drive an appliance via 5v opto-isolators.

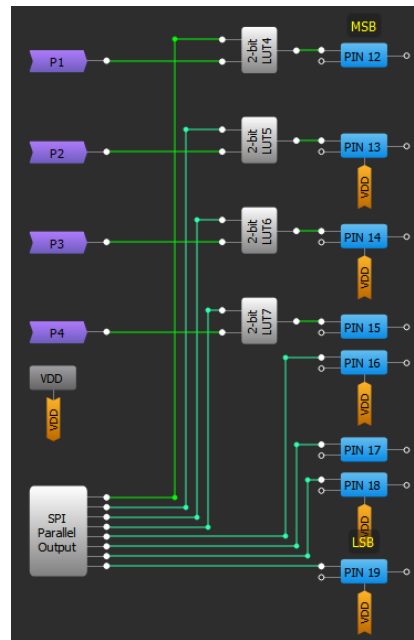

Figure 7. SPI Parallel Output Block Pins

Data Management at Power Distribution Company Network

The data received from consumer via the power line modem is received in a custom-built Visual C# application.



Figure 8. Visual C# Application for Receiving/Sending Data to/from consumer

This application is extremely easy to use. First, the user selects the serial Com Port that is connected to the KQ-330F. Then the user needs to select 9600 in the Baud Rate combo box. If everything is connected properly, pressing the 'Open Port' button will cause the status bar to start filling green.

After this, the personnel at Power Distribution Company can fully control the consumer appliances

by turning ON/OFF any connected appliance. The status of all the appliances will update accordingly on the C# application, and can also be posted on a webserver so that the consumer can view the status of their appliances.

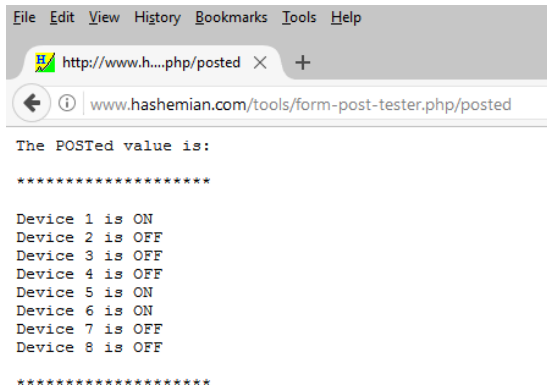

Figure 9. Device Status displayed on the internet

Conclusion

In this app note we demonstrated how to use a pair of the GreenPAK SLG46620V IC's and a pair of KQ-330F Power Line Communication Modems to remotely control power for up to 8 appliances. We created a Visual C# application for a user interface.

This concept can be scaled for many consumers and appliances, since one power distribution company could have several thousand customers.

IMPORTANT NOTICE AND DISCLAIMER

RENESAS ELECTRONICS CORPORATION AND ITS SUBSIDIARIES (“RENESAS”) PROVIDES TECHNICAL SPECIFICATIONS AND RELIABILITY DATA (INCLUDING DATASHEETS), DESIGN RESOURCES (INCLUDING REFERENCE DESIGNS), APPLICATION OR OTHER DESIGN ADVICE, WEB TOOLS, SAFETY INFORMATION, AND OTHER RESOURCES “AS IS” AND WITH ALL FAULTS, AND DISCLAIMS ALL WARRANTIES, EXPRESS OR IMPLIED, INCLUDING, WITHOUT LIMITATION, ANY IMPLIED WARRANTIES OF MERCHANTABILITY, FITNESS FOR A PARTICULAR PURPOSE, OR NON-INFRINGEMENT OF THIRD-PARTY INTELLECTUAL PROPERTY RIGHTS.

These resources are intended for developers who are designing with Renesas products. You are solely responsible for (1) selecting the appropriate products for your application, (2) designing, validating, and testing your application, and (3) ensuring your application meets applicable standards, and any other safety, security, or other requirements. These resources are subject to change without notice. Renesas grants you permission to use these resources only to develop an application that uses Renesas products. Other reproduction or use of these resources is strictly prohibited. No license is granted to any other Renesas intellectual property or to any third-party intellectual property. Renesas disclaims responsibility for, and you will fully indemnify Renesas and its representatives against, any claims, damages, costs, losses, or liabilities arising from your use of these resources. Renesas' products are provided only subject to Renesas' Terms and Conditions of Sale or other applicable terms agreed to in writing. No use of any Renesas resources expands or otherwise alters any applicable warranties or warranty disclaimers for these products.

(Disclaimer Rev.1.01)

Corporate Headquarters

TOYOSU FORESIA, 3-2-24 Toyosu,
Koto-ku, Tokyo 135-0061, Japan
www.renesas.com

Trademarks

Renesas and the Renesas logo are trademarks of Renesas Electronics Corporation. All trademarks and registered trademarks are the property of their respective owners.

Contact Information

For further information on a product, technology, the most up-to-date version of a document, or your nearest sales office, please visit www.renesas.com/contact-us/.