

Operational Amplifiers

Load Cancellation Enables Precision Op-Amps to Drive Heavy Loads

**Abstract**

The application note reviews how the load cancellation enables a precision op-amp to drive heavy loads without affecting its performance accuracy.

**Load Cancellation Enables Precision Op-Amps to Drive Heavy Load**

Precision op-amps are characterized by having a high open-loop gain, low offset voltage and current, low input voltage and current noise, and low distortion. However, these op-amps often lack the capability of a high output current drive and have a problem driving low-impedance loads.

With the help of a second op-amp that has a high drive capability but less DC precision, canceling the load enables the precision amp to control the current drive of its more powerful counterpart while maintaining a high precision performance.

One example of a load cancellation solution is to have the power driver generate a negative input resistance that matches the precision op-amp output load so that  $R_{IN} = -R_L$ . If connecting  $R_{IN}$  in parallel to  $R_L$ , the combined load resistance at the precision op-amp output becomes theoretically infinite.

Figure 1 shows a circuit that generates a negative input resistance of  $R_{IN} = -R_C \cdot R_G / R_F$ , where  $R_C$  is a compensation resistance.

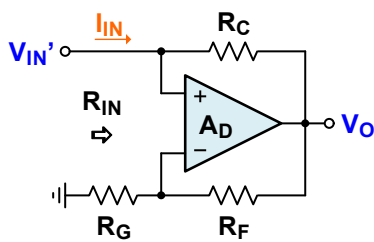

Figure 1. The Circuit Produces a Negative Input Resistance of  $R_{IN} = -R_C \cdot R_G / R_F$

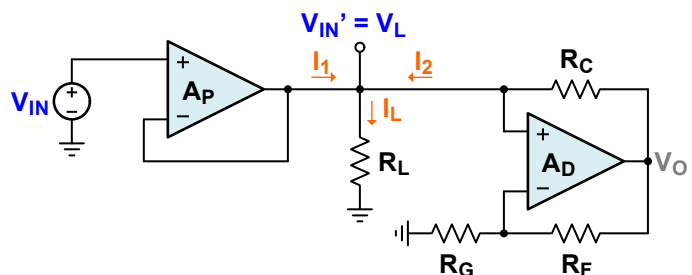

Figure 2. The Circuit Around  $A_D$  cancels the Load for  $A_P$

Equation 1 the input resistance of the circuit in Figure 1:

$$(EQ. 1) \quad R_{IN} = \frac{V_{IN}}{I_{IN}}$$

Use Equation 2 to express the input current:

$$(EQ. 2) \quad I_{IN} = \frac{V_{IN} - V_O}{R_C}$$

Use Equation 3 to express the op-amp output voltage:

$$(EQ. 3) \quad V_O = V_{IN} \left( 1 + \frac{R_F}{R_G} \right)$$

Insert Equation 2 and 3 and solve for the input resistance ( $V_{IN}/I_{IN}$ ) for the following result:

$$(EQ. 4) \quad R_{IN} = \frac{V_{IN}}{I_{IN}} = -R_C \cdot \frac{R_G}{R_F}$$

Figure 2 shows the theoretical concept of load cancellation, where a precision op-amp ( $A_P$ ) is configured as a unity-gain buffer; and, a wideband op-amp with high current drive capability ( $A_D$ ) operates as a non-inverting amplifier with a gain of two.

Because  $R_F = R_G$ , the negative input resistance of the circuit around  $A_D$  equals the compensation resistor,  $R_C$ :  $R_{IN} = -R_C$ . By making  $R_C = R_L$ , the output of the precision op-amp sees an open circuit.

As a result, the precision buffer ( $A_P$ ) drives the positive input of the wideband amplifier ( $A_D$ ) that drives the load.

**Note:** Gain error, output-current limits, and resistor mismatches limit the minimum load resistance that can be driven, but driving a  $200\Omega$  load is easy.

- This load is about 50-times lower than the precision amplifier can otherwise handle without suffering some loss of performance.
- Also, to the first order,  $A_P$  accuracy is not affected by the  $A_D$  gain error, offset voltage, and offset current.
- And  $A_D$  does not have significant positive feedback, because its non-inverting input is driven by the low output impedance of  $A_P$ .

Figure 3 shows the practical load cancellation circuit with the 40V precision op-amp, ISL28108, and the 60MHz wideband op-amp, EL5111. Both amplifiers operate from a bipolar supply of  $\pm 5V$ . Figure 4 shows the corresponding DC transfer characteristic for an input voltage and therefore shows the load voltage range of  $V_{IN} = V_L = \pm 2V$ .

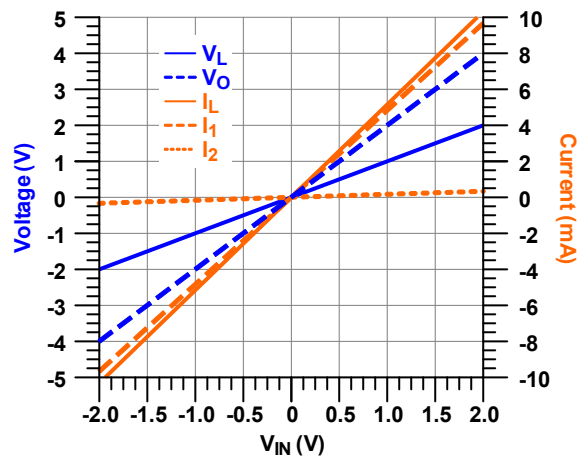
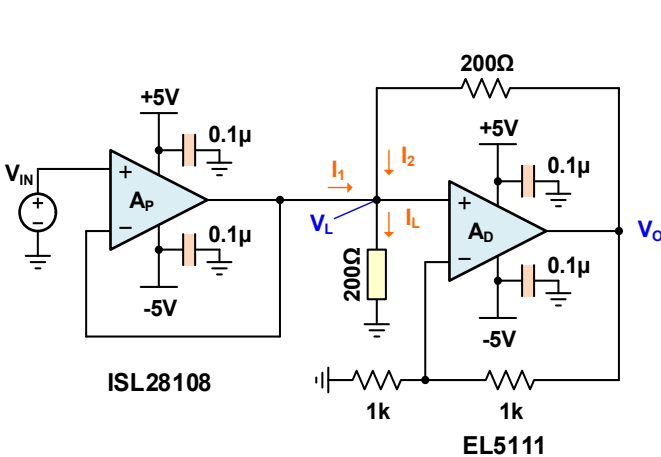

Figure 3. The Circuit Produces a Negative Input Resistance of  $R_{IN} = -R_C \cdot R_G / R_F$

Figure 4. The Circuit Around  $A_D$  cancels the Load for  $A_P$

These figures show that load cancellation enables a precision op-amp to drive heavy loads without affecting its performance accuracy.

## Revision History

Rev.	Date	Description
1.00	Jul.9.20	Initial release

## IMPORTANT NOTICE AND DISCLAIMER

RENESAS ELECTRONICS CORPORATION AND ITS SUBSIDIARIES (“RENESAS”) PROVIDES TECHNICAL SPECIFICATIONS AND RELIABILITY DATA (INCLUDING DATASHEETS), DESIGN RESOURCES (INCLUDING REFERENCE DESIGNS), APPLICATION OR OTHER DESIGN ADVICE, WEB TOOLS, SAFETY INFORMATION, AND OTHER RESOURCES “AS IS” AND WITH ALL FAULTS, AND DISCLAIMS ALL WARRANTIES, EXPRESS OR IMPLIED, INCLUDING, WITHOUT LIMITATION, ANY IMPLIED WARRANTIES OF MERCHANTABILITY, FITNESS FOR A PARTICULAR PURPOSE, OR NON-INFRINGEMENT OF THIRD PARTY INTELLECTUAL PROPERTY RIGHTS.

These resources are intended for developers skilled in the art designing with Renesas products. You are solely responsible for (1) selecting the appropriate products for your application, (2) designing, validating, and testing your application, and (3) ensuring your application meets applicable standards, and any other safety, security, or other requirements. These resources are subject to change without notice. Renesas grants you permission to use these resources only for development of an application that uses Renesas products. Other reproduction or use of these resources is strictly prohibited. No license is granted to any other Renesas intellectual property or to any third party intellectual property. Renesas disclaims responsibility for, and you will fully indemnify Renesas and its representatives against, any claims, damages, costs, losses, or liabilities arising out of your use of these resources. Renesas' products are provided only subject to Renesas' Terms and Conditions of Sale or other applicable terms agreed to in writing. No use of any Renesas resources expands or otherwise alters any applicable warranties or warranty disclaimers for these products.

(Rev.1.0 Mar 2020)

### Corporate Headquarters

TOYOSU FORESIA, 3-2-24 Toyosu,  
Koto-ku, Tokyo 135-0061, Japan  
[www.renesas.com](http://www.renesas.com)

### Contact Information

For further information on a product, technology, the most up-to-date version of a document, or your nearest sales office, please visit:  
[www.renesas.com/contact/](http://www.renesas.com/contact/)

### Trademarks

Renesas and the Renesas logo are trademarks of Renesas Electronics Corporation. All trademarks and registered trademarks are the property of their respective owners.