

To our customers,

Old Company Name in Catalogs and Other Documents

On April 1st, 2010, NEC Electronics Corporation merged with Renesas Technology Corporation, and Renesas Electronics Corporation took over all the business of both companies. Therefore, although the old company name remains in this document, it is a valid Renesas Electronics document. We appreciate your understanding.

Renesas Electronics website: <http://www.renesas.com>

April 1st, 2010
Renesas Electronics Corporation

Issued by: Renesas Electronics Corporation (<http://www.renesas.com>)

Send any inquiries to <http://www.renesas.com/inquiry>.

Note that the following URLs in this document are not available:

<http://www.necel.com/>

<http://www2.renesas.com/>

Please refer to the following instead:

Development Tools | <http://www.renesas.com/tools>

Download | http://www.renesas.com/tool_download

For any inquiries or feedback, please contact your region.

<http://www.renesas.com/inquiry>

Notice

1. All information included in this document is current as of the date this document is issued. Such information, however, is subject to change without any prior notice. Before purchasing or using any Renesas Electronics products listed herein, please confirm the latest product information with a Renesas Electronics sales office. Also, please pay regular and careful attention to additional and different information to be disclosed by Renesas Electronics such as that disclosed through our website.
2. Renesas Electronics does not assume any liability for infringement of patents, copyrights, or other intellectual property rights of third parties by or arising from the use of Renesas Electronics products or technical information described in this document. No license, express, implied or otherwise, is granted hereby under any patents, copyrights or other intellectual property rights of Renesas Electronics or others.
3. You should not alter, modify, copy, or otherwise misappropriate any Renesas Electronics product, whether in whole or in part.
4. Descriptions of circuits, software and other related information in this document are provided only to illustrate the operation of semiconductor products and application examples. You are fully responsible for the incorporation of these circuits, software, and information in the design of your equipment. Renesas Electronics assumes no responsibility for any losses incurred by you or third parties arising from the use of these circuits, software, or information.
5. When exporting the products or technology described in this document, you should comply with the applicable export control laws and regulations and follow the procedures required by such laws and regulations. You should not use Renesas Electronics products or the technology described in this document for any purpose relating to military applications or use by the military, including but not limited to the development of weapons of mass destruction. Renesas Electronics products and technology may not be used for or incorporated into any products or systems whose manufacture, use, or sale is prohibited under any applicable domestic or foreign laws or regulations.
6. Renesas Electronics has used reasonable care in preparing the information included in this document, but Renesas Electronics does not warrant that such information is error free. Renesas Electronics assumes no liability whatsoever for any damages incurred by you resulting from errors in or omissions from the information included herein.
7. Renesas Electronics products are classified according to the following three quality grades: “Standard”, “High Quality”, and “Specific”. The recommended applications for each Renesas Electronics product depends on the product’s quality grade, as indicated below. You must check the quality grade of each Renesas Electronics product before using it in a particular application. You may not use any Renesas Electronics product for any application categorized as “Specific” without the prior written consent of Renesas Electronics. Further, you may not use any Renesas Electronics product for any application for which it is not intended without the prior written consent of Renesas Electronics. Renesas Electronics shall not be in any way liable for any damages or losses incurred by you or third parties arising from the use of any Renesas Electronics product for an application categorized as “Specific” or for which the product is not intended where you have failed to obtain the prior written consent of Renesas Electronics. The quality grade of each Renesas Electronics product is “Standard” unless otherwise expressly specified in a Renesas Electronics data sheets or data books, etc.
 - “Standard”: Computers; office equipment; communications equipment; test and measurement equipment; audio and visual equipment; home electronic appliances; machine tools; personal electronic equipment; and industrial robots.
 - “High Quality”: Transportation equipment (automobiles, trains, ships, etc.); traffic control systems; anti-disaster systems; anti-crime systems; safety equipment; and medical equipment not specifically designed for life support.
 - “Specific”: Aircraft; aerospace equipment; submersible repeaters; nuclear reactor control systems; medical equipment or systems for life support (e.g. artificial life support devices or systems), surgical implantations, or healthcare intervention (e.g. excision, etc.), and any other applications or purposes that pose a direct threat to human life.
8. You should use the Renesas Electronics products described in this document within the range specified by Renesas Electronics, especially with respect to the maximum rating, operating supply voltage range, movement power voltage range, heat radiation characteristics, installation and other product characteristics. Renesas Electronics shall have no liability for malfunctions or damages arising out of the use of Renesas Electronics products beyond such specified ranges.
9. Although Renesas Electronics endeavors to improve the quality and reliability of its products, semiconductor products have specific characteristics such as the occurrence of failure at a certain rate and malfunctions under certain use conditions. Further, Renesas Electronics products are not subject to radiation resistance design. Please be sure to implement safety measures to guard them against the possibility of physical injury, and injury or damage caused by fire in the event of the failure of a Renesas Electronics product, such as safety design for hardware and software including but not limited to redundancy, fire control and malfunction prevention, appropriate treatment for aging degradation or any other appropriate measures. Because the evaluation of microcomputer software alone is very difficult, please evaluate the safety of the final products or system manufactured by you.
10. Please contact a Renesas Electronics sales office for details as to environmental matters such as the environmental compatibility of each Renesas Electronics product. Please use Renesas Electronics products in compliance with all applicable laws and regulations that regulate the inclusion or use of controlled substances, including without limitation, the EU RoHS Directive. Renesas Electronics assumes no liability for damages or losses occurring as a result of your noncompliance with applicable laws and regulations.
11. This document may not be reproduced or duplicated, in any form, in whole or in part, without prior written consent of Renesas Electronics.
12. Please contact a Renesas Electronics sales office if you have any questions regarding the information contained in this document or Renesas Electronics products, or if you have any other inquiries.

(Note 1) “Renesas Electronics” as used in this document means Renesas Electronics Corporation and also includes its majority-owned subsidiaries.

(Note 2) “Renesas Electronics product(s)” means any product developed or manufactured by or for Renesas Electronics.

User's Manual

CA850 Ver. 3.20

C Compiler Package

Operation

Target Device V850 Series

[MEMO]

Windows is either a registered trademark or a trademark of Microsoft Corporation in the United States and/or other countries.

- **The information in this document is current as of May, 2007. The information is subject to change without notice. For actual design-in, refer to the latest publications of NEC Electronics data sheets or data books, etc., for the most up-to-date specifications of NEC Electronics products. Not all products and/or types are available in every country. Please check with an NEC Electronics sales representative for availability and additional information.**

- No part of this document may be copied or reproduced in any form or by any means without the prior written consent of NEC Electronics. NEC Electronics assumes no responsibility for any errors that may appear in this document.
- NEC Electronics does not assume any liability for infringement of patents, copyrights or other intellectual property rights of third parties by or arising from the use of NEC Electronics products listed in this document or any other liability arising from the use of such products. No license, express, implied or otherwise, is granted under any patents, copyrights or other intellectual property rights of NEC Electronics or others.
- Descriptions of circuits, software and other related information in this document are provided for illustrative purposes in semiconductor product operation and application examples. The incorporation of these circuits, software and information in the design of a customer's equipment shall be done under the full responsibility of the customer. NEC Electronics assumes no responsibility for any losses incurred by customers or third parties arising from the use of these circuits, software and information.
- While NEC Electronics endeavors to enhance the quality, reliability and safety of NEC Electronics products, customers agree and acknowledge that the possibility of defects thereof cannot be eliminated entirely. To minimize risks of damage to property or injury (including death) to persons arising from defects in NEC Electronics products, customers must incorporate sufficient safety measures in their design, such as redundancy, fire-containment and anti-failure features.
- NEC Electronics products are classified into the following three quality grades: "Standard", "Special" and "Specific".

The "Specific" quality grade applies only to NEC Electronics products developed based on a customer-designated "quality assurance program" for a specific application. The recommended applications of an NEC Electronics product depend on its quality grade, as indicated below. Customers must check the quality grade of each NEC Electronics product before using it in a particular application.

"Standard": Computers, office equipment, communications equipment, test and measurement equipment, audio and visual equipment, home electronic appliances, machine tools, personal electronic equipment and industrial robots.

"Special": Transportation equipment (automobiles, trains, ships, etc.), traffic control systems, anti-disaster systems, anti-crime systems, safety equipment and medical equipment (not specifically designed for life support).

"Specific": Aircraft, aerospace equipment, submersible repeaters, nuclear reactor control systems, life support systems and medical equipment for life support, etc.

The quality grade of NEC Electronics products is "Standard" unless otherwise expressly specified in NEC Electronics data sheets or data books, etc. If customers wish to use NEC Electronics products in applications not intended by NEC Electronics, they must contact an NEC Electronics sales representative in advance to determine NEC Electronics' willingness to support a given application.

(Note)

- (1) "NEC Electronics" as used in this statement means NEC Electronics Corporation and also includes its majority-owned subsidiaries.
- (2) "NEC Electronics products" means any product developed or manufactured by or for NEC Electronics (as defined above).

[MEMO]

INTRODUCTION

Target Devices The CA850 is a C compiler package used to create object codes for NEC Electronics's V850 Series of RISC microcontrollers.
This manual explains the features and functions of the CA850 C Compiler Package.

Readers This manual is intended for user engineers who wish to develop application systems using the V850 Series C Compiler Package.

Purpose This manual explains how to operate each command, such as the C compiler and assembler included in each package on Windows™.
PM+ (Windows version only) is provided with this C compiler package. However, for how to operate PM+ as an integrated development environment, refer to the PM+ user's manual.
For the Windows operations, refer to the function guides provided with the Windows OS.

Organization This manual is organized into the following sections.

- Overview of the CA850
- Using the CA850 from the command line
- Using the CA850 from Project Manager
- Command functions, options, and output messages

Commands Included in This Package
C compiler (ca850)
Assembler (as850)
Linker (ld850)
ROMization processor (romp850)
Hexadecimal converter (hx850)
Archiver (ar850)
Section file generator (sf850)
Dump command (dump850)
Disassembler (dis850)
Cross reference tool (cxref)
Memory layout visualization tool (rammap)
Stack estimation tool (stk850)

How to Read This Manual • The name of each program in the C compiler package is referred to as follows in this manual.

C compiler package → CA850
Assembler → as850
C compiler → ca850

Related Documents

Read this manual together with the following documents.

The related documents indicated in this publication may include preliminary versions. However, preliminary versions are not marked as such.

Documents related to development tools (user's manuals)

Document Name		Document No.
CA850 Ver. 3.20 C Compiler Package	Operation	This manual
	C Language	U18513E
	Assembly Language	U18514E
	Link Directives	U18515E
PM+ Ver. 6.30 Project Manager		U18416E
ID850 Ver. 3.00 Integrated Debugger	Operation	U17358E
ID850NW Ver. 3.10 Integrated Debugger	Operation	U17369E
ID850QB Ver. 3.20 Integrated Debugger	Operation	U17964E
SM+ System Simulator	Operation	U17246E
	User Open Interface	U18212E
SM850 Ver. 2.50 System Simulator	Operation	U16218E
SM850 Ver. 2.00 or Later System Simulator	External Part User Open Interface Specifications	U14873E
RX850 Ver. 3.20 or Later Real-Time OS	Basics	U13430E
	Installation	U17419E
	Technical	U13431E
	Task Debugger	U17420E
RX850 Pro Ver. 3.21 Real-Time OS	Basics	U18165E
	Internal Structure	U18164E
	Task Debugger	U17422E
RX850V4 Ver. 4.22 Real-Time OS	Functionalities	U16643E
	Internal Structure	U16644E
	Task Debugger	U16811E
AZ850 Ver. 3.30 System Performance Analyzer		U17423E
AZ850V4 Ver. 4.10 System Performance Analyzer		U17093E
TW850 Ver. 2.00 Performance Analysis Tuning Tool		U17241E

[MEMO]

CONTENTS

CHAPTER 1 OVERVIEW ...	20
1.1 Features of Compiler Package ...	20
1.2 Operating Environments ...	22
CHAPTER 2 INSTALLATION ...	23
2.1 Installation ...	23
2.2 Folder Organization ...	24
2.2.1 Folder organization of stack usage tracer ...	25
2.3 Uninstallation ...	26
CHAPTER 3 C COMPILER ...	27
3.1 Flow of Operation ...	27
3.2 Input/Output Files ...	29
3.3 Executable Object ...	30
3.4 Operation Method ...	32
3.4.1 Command input method ...	32
3.4.2 Method using PM+ ...	32
3.5 Types and Features of Options ...	33
3.5.1 Version/help display/operation status ...	34
3.5.2 Output file specification ...	35
3.5.3 Controlling source debugger ...	37
3.5.4 Control of compile driver ...	38
3.5.5 Optimization ...	44
3.5.6 Generation code control ...	49
3.5.7 Library specification ...	59
3.5.8 Warning message control ...	60
3.5.9 Other ...	62
3.5.10 Option to each module ...	64
3.6 Settings Made via PM+ ...	68
3.6.1 [Compiler Common Options] dialog box ...	69
[File] ...	70
[Startup] ...	72
[Link Directive] ...	73
[ROM] ...	74
[Flash] ...	75
[Device] ...	76
[ROM] (library) ...	78
[Flash] (library) ...	79
3.6.2 [Compiler Options] dialog box ...	80
[General] ...	81
[Input File] ...	84
[Preprocessor] ...	86
[C Language] ...	88
[Optimization and Debug Information] ...	90
[Detail of Optimization] ...	92
[External Register] ...	96
[Output File] ...	98
[Output Code] ...	100
[Message] ...	105
[Assembler] ...	107
[Others] ...	109
[Difference] ...	111

3.6.3 [Edit Option] dialog box ...	113
3.7 Cautions ...	115
3.7.1 Specifying multiple options ...	115
3.7.2 Command file ...	116
3.7.3 Efficient use of optimization ...	117
3.7.4 Effects of optimization on debugging ...	122
 CHAPTER 4 ASSEMBLER ...	 124
4.1 Flow of Operation ...	124
4.2 Input/Output Files ...	125
4.3 Operation Method ...	126
4.3.1 Command input method ...	126
4.3.2 Method using PM+ ...	126
4.4 Types and Features of Options ...	127
4.4.1 File ...	128
4.4.2 Option ...	129
4.4.3 Device ...	131
4.4.4 Other ...	133
4.5 Settings Made via PM+ ...	135
4.5.1 [Assembler Options] dialog box ...	136
[Option] ...	137
[Difference] ...	141
4.6 Assemble List ...	143
4.6.1 Output method ...	143
4.6.2 Output example ...	144
4.7 Cautions ...	146
4.7.1 Magic number ...	146
4.7.2 Options for avoiding CPU faults ...	148
 CHAPTER 5 LINKER ...	 153
5.1 Flow of Operation ...	153
5.1.1 Link procedure ...	155
5.2 Operation Method ...	157
5.2.1 Command input method ...	157
5.2.2 Method using PM+ ...	157
5.3 Types and Features of Options ...	158
5.3.1 Input file ...	159
5.3.2 Output file ...	160
5.3.3 Library ...	161
5.3.4 Flash ROM ...	162
5.3.5 Device ...	164
5.3.6 Option ...	165
5.3.7 Other ...	168
5.4 Settings Made via PM+ ...	170
5.4.1 [Linker Options] dialog box ...	170
[File] ...	171
[Library] ...	172
[Option] ...	174
[Others] ...	177
5.5 Link Map ...	178
5.5.1 When starting the ld850 from the command line ...	178
5.5.2 When starting from PM+ ...	178
5.5.3 Link map output example ...	178
5.6 Flash Memory/External ROM Relink Function ...	181
5.6.1 Relink function ...	181
5.6.2 Image of relink function ...	182

5.6.3	Realizing relink function ...	185
5.7	Supplementary Information ...	194
5.7.1	Using -A option ...	194
5.7.2	Archive files ...	197
5.7.3	Reserved symbols ...	198
5.7.4	May not be allocated to the expected sections ...	199
5.7.5	V850 core and V850Ex core ...	199
5.7.6	V850 core and V850E2 core ...	199
5.7.7	Mathematics library ...	199
5.7.8	main function ...	199
5.7.9	Prologue/epilogue runtime library ...	200
5.7.10	Linking for ROMization ...	201
5.7.11	Programmable peripheral I/O register ...	202
5.7.12	Option byte ...	203
CHAPTER 6	ROMIZATION PROCESSOR ...	204
6.1	Flow of Operation ...	204
6.2	Input/Output Files ...	207
6.3	rompsec Section ...	208
6.3.1	Types of sections to be packed ...	208
6.3.2	Size of rompsec section ...	209
6.3.3	rompsec section and link directive ...	210
6.4	Creating Object for ROMization ...	212
6.4.1	Creating procedure (default) ...	212
6.4.2	Creating procedure (customize) ...	215
6.5	Copy Functions ...	218
6.5.1	Copy routine ...	218
_rcopy	...	219
_rcopy1	...	220
_rcopy2	...	221
_rcopy4	...	222
6.5.2	Example ...	223
6.6	Operation Method ...	225
6.6.1	Command input method ...	225
6.6.2	Method using PM+ ...	225
6.7	Types and Features of Options ...	226
6.7.1	File ...	227
6.7.2	Options ...	228
6.7.3	Other ...	230
6.8	Settings Made via PM+ ...	231
6.8.1	[ROM Processor Options] dialog box ...	231
[File]	...	232
[Section]	...	233
[Option]	...	235
[Others]	...	237
CHAPTER 7	HEXADECIMAL CONVERTER ...	238
7.1	Flow of Operation ...	238
7.2	Input/Output Files ...	239
7.3	Operation Method ...	240
7.3.1	Command input method ...	240
7.3.2	Method using PM+ ...	240
7.4	Types and Features of Options ...	241
7.4.1	File ...	242
7.4.2	Format ...	243
7.4.3	Other ...	246

7.5 Settings Made via PM+ ...	247
7.5.1 [Hexa Converter Options] dialog box ...	247
[File] ...	248
[Option] ...	249
[Others] ...	252
7.6 Output File Formats ...	253
7.6.1 Intel expanded ...	253
7.6.2 Motorola S type ...	257
7.6.3 Expanded Tek ...	259
CHAPTER 8 ARCHIVER ...	263
8.1 Archiver ...	263
8.2 Operation Method ...	264
8.2.1 Command input method ...	264
8.2.2 Method using PM+ ...	264
8.3 Types and Features of Keys and Options ...	265
8.3.1 Types and features of keys ...	266
8.3.2 Types and features of options ...	268
8.4 Settings Made via PM+ ...	269
8.4.1 [Archiver Options] dialog box ...	269
[Option] ...	270
CHAPTER 9 SECTION FILE GENERATOR ...	272
9.1 Section Files ...	272
9.2 Section File Format ...	275
9.3 Operation Method ...	280
9.3.1 Command input method ...	280
9.3.2 Method using PM+ ...	280
9.3.3 Use from command line ...	281
9.3.4 Use via PM+ ...	282
9.4 Types and Features of Options ...	283
9.4.1 Options ...	284
9.5 Settings Made via PM+ ...	287
9.5.1 [Section File Generator Options] dialog box ...	287
[File] ...	288
[Option] ...	289
[Others] ...	292
CHAPTER 10 DUMP COMMAND ...	293
10.1 Dump Command ...	293
10.2 Operation Method ...	294
10.2.1 Command input method ...	294
10.2.2 Method using PM+ ...	294
10.3 Types and Features of Options ...	295
10.4 Settings Made via PM+ ...	297
10.4.1 [Object Analysis Tool] dialog box ...	297
[Dump] ...	298
10.4.2 [Output Index] dialog box ...	302
10.4.3 [Archive File Options] dialog box ...	303
10.5 Dump List ...	304
10.5.1 Dump list display contents ...	304
10.5.2 Element values and meanings ...	310
CHAPTER 11 DISASSEMBLER ...	313
11.1 Disassembler ...	313

11.2	Operation Method ...	314
11.2.1	Command input method ...	314
11.2.2	Method using PM+ ...	314
11.3	Types and Features of Options ...	315
11.4	Settings Made via PM+ ...	317
11.4.1	[Object Analysis Tool] dialog box ...	317
	[Disassembler] ...	318
11.5	Cautions ...	321
11.6	Output Format ...	322
CHAPTER 12 CROSS REFERENCE TOOL ... 323		
12.1	Cross Reference Tool ...	323
12.2	Input/Output ...	324
12.2.1	Input file ...	324
12.2.2	Output information ...	325
12.3	Operation Method ...	326
12.3.1	Command input method ...	326
12.3.2	Method using PM+ ...	326
12.4	Types and Features of Options ...	327
12.4.1	Common options ...	328
12.4.2	Cross reference ...	331
12.4.3	Tag information ...	332
12.4.4	Call tree ...	333
12.4.5	Function metrics ...	334
12.4.6	Call database ...	335
12.5	Settings Made via PM+ ...	336
12.5.1	[Static performance analyzer] dialog box ...	336
	[Cross reference] ...	337
12.5.2	[Cross reference Option] dialog box ...	340
	[Common option] ...	341
	[Cross reference list] ...	344
	[Tag information] ...	345
	[Call graph] ...	346
	[Function measure] ...	349
	[Call database] ...	351
12.6	Output Files ...	353
12.6.1	Cross reference ...	353
12.6.2	Tag information ...	355
12.6.3	Call tree ...	357
12.6.4	Function metrics ...	360
12.6.5	Call database ...	363
CHAPTER 13 MEMORY LAYOUT VISUALIZATION TOOL ... 366		
13.1	Memory Layout Visualization Tool ...	366
13.2	Input/Output ...	367
13.2.1	Input file ...	367
13.2.2	Output information ...	367
13.3	Operation Method ...	368
13.3.1	Command input method ...	368
13.3.2	Method using PM+ ...	368
13.4	Types and Features of Options ...	369
13.5	Settings Made via PM+ ...	372
13.5.1	[Static performance analyzer] dialog box ...	372
	[RAM map] ...	373
13.5.2	[RAM map option] dialog box ...	375
	[Common option] ...	376

13.5.3 [Object Analysis Tool] dialog box ...	378
[RAM map] ...	379
13.6 Output Files ...	381
13.6.1 Memory map table ...	381
CHAPTER 14 STACK USAGE TRACER ...	383
14.1 Flow of Operation ...	383
14.2 Input/Output Files ...	384
14.2.1 Input files ...	384
14.2.2 Output file ...	384
14.3 Operation Method ...	385
14.4 Window Reference ...	386
Main window ...	388
[Adjust Stack Size] dialog box ...	392
[Stack Size Unknown / Adjusted Function Lists] dialog box ...	394
[About stk850] dialog box ...	396
14.5 Cautions ...	397
14.5.1 Quantitative limit of the stk850 ...	397
14.6 Output File Formats ...	399
14.6.1 Output result files ...	399
14.6.2 Stack size specification file ...	402
14.6.3 stk system file ...	405
APPENDIX A FORMAT OF OBJECT FILE ...	406
A.1 Structure of Object File ...	406
A.2 ELF Header ...	407
A.3 Program Header Table ...	408
A.4 Section Header Table ...	409
A.4.1 Section types ...	410
A.4.2 Constituent elements (link/info) dependent on section type ...	410
A.5 Sections ...	411
A.5.1 Symbol table ...	411
A.5.2 String table ...	412
A.5.3 Reserved sections ...	413
APPENDIX B MESSAGE ...	415
B.1 Output Message ...	415
B.1.1 Message format ...	415
B.1.2 Compiler ...	416
B.1.3 Assembler ...	442
B.1.4 Linker ...	450
B.1.5 ROMization process ...	468
B.1.6 Hexadecimal converter ...	471
B.1.7 Archiver ...	477
B.1.8 Section file generator ...	479
B.1.9 Dump command ...	480
B.1.10 Disassembler ...	481
B.1.11 Cross reference tool ...	482
B.1.12 Memory layout visualization tool ...	484
B.2 Messages from PM+ ...	486
B.2.1 Format of message ...	486
B.2.2 Messages common to compiler ...	486
B.2.3 Compiler ...	487
B.2.4 Assembler ...	488
B.2.5 Linker ...	488
B.2.6 ROMization processor ...	489

B.2.7 Hexadecimal converter ...	489
B.2.8 Archiver ...	490
B.2.9 Section file generator ...	490
B.2.10 Cross reference tool and memory layout visualization tool ...	491
B.3 Messages from stk850 ...	493
B.3.1 Message formats ...	493
B.3.2 Messages ...	493
APPENDIX C INDEX ...	498

LIST OF FIGURES

Figure No. Title Page

1 - 1	Package Configuration ...	21
2 - 1	Folder Organization ...	24
2 - 2	Folder Organization of Stack Usage Tracer ...	25
3 - 1	Operation Flow of ca850 ...	28
3 - 2	[Compiler Common Options] Dialog Box ([File] Tab) ...	70
3 - 3	Checking Creation of Folder ...	71
3 - 4	[Compiler Common Options] Dialog Box ([Startup] Tab) ...	72
3 - 5	[Compiler Common Options] Dialog Box ([Link Directive] Tab) ...	73
3 - 6	[Compiler Common Options] Dialog Box ([ROM] Tab) ...	74
3 - 7	[Compiler Common Options] Dialog Box ([Flash] Tab) ...	75
3 - 8	[Compiler Common Options] Dialog Box ([Device] Tab) ...	76
3 - 9	[Compiler Common Options] Dialog Box ([ROM] Tab (library)) ...	78
3 - 10	[Compiler Common Options] Dialog Box ([Flash] Tab (library)) ...	79
3 - 11	[Compiler Options] Dialog Box ([General] Tab) ...	81
3 - 12	[Compiler Options] Dialog Box ([Input File] Tab) ...	84
3 - 13	[Compiler Options] Dialog Box ([Preprocessor] Tab) ...	86
3 - 14	[Compiler Options] Dialog Box ([C Language] Tab) ...	88
3 - 15	[Compiler Options] Dialog Box ([Optimization and Debug Information] Tab) ...	90
3 - 16	[Compiler Options] Dialog Box ([Detail of Optimization] Tab) ...	92
3 - 17	Output Example (Function Name func) ...	93
3 - 18	[Compiler Options] Dialog Box ([External Register] Tab) ...	96
3 - 19	[Compiler Options] Dialog Box ([Output File] Tab) ...	98
3 - 20	[Compiler Options] Dialog Box ([Output Code] Tab) ...	100
3 - 21	[Compiler Options] Dialog Box ([Message] Tab) ...	105
3 - 22	[Compiler Options] Dialog Box ([Assembler] Tab) ...	107
3 - 23	[Compiler Options] Dialog Box ([Others] Tab) ...	109
3 - 24	[Compiler Options] Dialog Box ([Difference] Tab) ...	111
3 - 25	[Edit Option] Dialog Box ...	113
3 - 26	[Add Option] Dialog Box ...	113
3 - 27	Optimization Processing and Parameters ...	117
4 - 1	Operation Flow of as850 ...	124
4 - 2	[Assembler Options] Dialog Box ([Option] Tab) ...	137
4 - 3	[Assembler Options] Dialog Box ([Difference] Tab) ...	141
4 - 4	Example of Output Assemble List ...	144
4 - 5	Image of Creating Common Object with as850 ...	146
4 - 6	Example of as850 CPU Core Compatibility (V850Ex Core and V850 Core) ...	147
5 - 1	Operation Flow of ld850 ...	153
5 - 2	ld850 Operation Image (Example) ...	154
5 - 3	Batch Processing ...	154
5 - 4	Modular Processing ...	154
5 - 5	Creation of Output Section ...	155
5 - 6	Allocation to Memory Space ...	155
5 - 7	[Linker Options] Dialog Box ...	170
5 - 8	[Linker Options] Dialog Box ([File] Tab) ...	171
5 - 9	[Linker Options] Dialog Box ([Library] Tab) ...	172
5 - 10	[Library List] Dialog Box ...	173
5 - 11	[Linker Options] Dialog Box ([Option] Tab) ...	174
5 - 12	[Linker Options] Dialog Box ([Others] Tab) ...	177
5 - 13	Link Map Output Example ...	179
5 - 14	In Fixed ROM ...	182
5 - 15	In Flash Memory ...	182
5 - 16	From Fixed ROM to Flash Memory ...	183
5 - 17	From Flash Memory to Fixed ROM ...	184
5 - 18	Compiler Common Options for Flash Memory ...	191
5 - 19	Compiler Common Options for Fixed ROM ...	191
5 - 20	Memory Allocation Image of gp Offset Reference Section ...	194

5 - 21	Example of Output Information on Executable Object File ...	195
5 - 22	Example of Output Information on Relocatable Object File ...	196
6 - 1	Creation of Object for ROMization ...	204
6 - 2	Image of Processing Immediately After _rcopy Function Call ...	205
6 - 3	Link Directive Taking ROMization Processing into Consideration ...	210
6 - 4	Link Directive Taking ROMization Processing into Consideration (Size Considered) ...	211
6 - 5	Example of Using Copy Function _rcopy 1 ...	212
6 - 6	ROMization Image 1 ...	214
6 - 7	Example of rompack.s ...	215
6 - 8	Example of Using Copy Function _rcopy 2 ...	215
6 - 9	Link Directive Specification Example ...	216
6 - 10	ROMization Image 2 ...	217
6 - 11	[ROM Processor Options] Dialog Box ([File] Tab) ...	232
6 - 12	[ROM Processor Options] Dialog Box ([Section] Tab) ...	233
6 - 13	[ROM Processor Options] Dialog Box ([Option] Tab) ...	235
6 - 14	[ROM Processor Options] Dialog Box ([Others] Tab) ...	237
7 - 1	Operation Flow in hx850 ...	238
7 - 2	[Hexa Converter Options] Dialog Box ([File] Tab) ...	248
7 - 3	[Hexa Converter Options] Dialog Box ([Option] Tab) ...	249
7 - 4	[Hexa Converter Options] Dialog Box ([Others] Tab) ...	252
7 - 5	File Configuration in Intel Expanded Hex Format ...	253
7 - 6	File Configuration of Motorola S Type Hex Format ...	257
7 - 7	File Configuration of Expanded Tek Hex Format ...	259
8 - 1	The ar850's Operation Flow ...	263
8 - 2	[Archiver Options] Dialog Box ([Option] Tab) ...	270
9 - 1	Image of Compilation Using Section File Specifications ...	273
9 - 2	Example of Section File Output by sf850 ...	275
9 - 3	Example of Section File Output by sf850 Using -O Option ...	276
9 - 4	[Section File Generator Options] Dialog Box ([File] Tab) ...	288
9 - 5	[Section File Generator Options] Dialog Box ([Option] Tab) ...	289
9 - 6	[Section File Generator Options] Dialog Box ([Others] Tab) ...	292
10 - 1	Operation Flow of dump850 ...	293
10 - 2	[Object Analysis Tool] Dialog Box ([Dump] Tab) ...	298
10 - 3	[Output Index] Dialog Box ...	302
10 - 4	[Archive File Options] Dialog Box ...	303
11 - 1	Operation Flow of dis850 Command ...	313
11 - 2	[Object Analysis Tool] Dialog Box ([Disassembler] Tab) ...	318
12 - 1	Flow of Operation in cxref ...	323
12 - 2	[Static performance analyzer] Dialog Box (Cross reference) ...	337
12 - 3	[Cross reference option] Dialog Box ([Common option] Tab) ...	341
12 - 4	[Cross reference option] Dialog Box ([Cross reference list] Tab) ...	344
12 - 5	[Cross reference option] Dialog Box ([Tag information] Tab) ...	345
12 - 6	[Cross reference option] Dialog Box ([Call graph] Tab) ...	346
12 - 7	[Cross reference option] Dialog Box ([Function measure] Tab) ...	349
12 - 8	[Cross reference option] Dialog Box ([Call database] Tab) ...	351
12 - 9	Cross Reference Output Example (cxref) ...	353
12 - 10	Tag Information Output Example (cxref) ...	355
12 - 11	Call Tree Text-Format Output Example (cxref) ...	357
12 - 12	Call Tree CSV-Format Output Example (cxref) ...	358
12 - 13	Function Metrics Text-Format Output Example (cxref) ...	360
12 - 14	Function Metrics CSV-Format Output Example (cxref) ...	361
12 - 15	Call Database Text-Format Output Example (cxref) ...	363
12 - 16	Call Database CSV-Format Output Example (cxref) ...	364
13 - 1	Flow of Operation in rammap ...	366
13 - 2	[Static performance analyzer] Dialog Box ([RAM map] Tab) ...	373
13 - 3	[RAM map option] Dialog Box ([Common option] Tab) ...	376
13 - 4	[Object Analysis Tool] Dialog Box ([RAM map] Tab) ...	379
13 - 5	Memory Map Table Text-Format Output Example (rammap) ...	381
13 - 6	Memory Map Table CSV-Format Output Example (rammap) ...	382
14 - 1	Estimation Flow in stk850 ...	383
14 - 2	Main Window of st850 ...	388
14 - 3	[Adjust Stack Size] Dialog Box ...	392
14 - 4	[Stack Size Unknown / Adjusted Function Lists] Dialog Box ...	394

14 - 5	[About stk850] Dialog Box ...	396
A - 1	Object File Structures ...	406
B - 1	Example of Message Dialog Box ...	486

LIST OF TABLES

Table No. Title Page

3 - 1	Register Mode ...	49
3 - 2	Correspondence Between CPU Core and -Xv850patch Option for This Bug ...	63
3 - 3	[Compiler Common Options] Dialog Box ...	69
3 - 4	[Compiler Common Options] Dialog Box (library) ...	69
3 - 5	[Compiler Options] Dialog Box ...	80
3 - 6	[Compiler Options] Dialog Box (Individual Source) ...	80
3 - 7	Message Numbers of Messages That Can Be Specified ...	106
3 - 8	Optimization Processing and Items ...	117
4 - 1	[Assembler Options] Dialog Box ...	136
4 - 2	[Assembler Options] Dialog Box (Individual Source) ...	136
4 - 3	Section Attributes and Their Meanings ...	145
4 - 4	Correspondence Between CPU Core and -p Option ...	149
4 - 5	Correspondence Between Created Objects and -p Options ...	152
5 - 1	Reserved Section ...	198
5 - 2	Special Symbols in Ordinary Object File ...	198
6 - 1	Reserved Sections Packed by romp850 ...	208
6 - 2	Copy Routines ...	218
6 - 3	[ROM Processor Options] Dialog Box ...	231
7 - 1	HEX Format Block/Record ...	243
7 - 2	[Hexa Converter Options] Dialog Box ...	247
7 - 3	HEX Format Block/Record ...	251
8 - 1	[Archiver Options] Dialog Box ...	269
9 - 1	Variable Types and Displays ...	275
9 - 2	Variable Displays and Their Meanings ...	276
9 - 3	Types of Sections Specifiable by ca850 ...	277
9 - 4	[Section File Generator Options] Dialog Box ...	287
10 - 1	[Object Analysis Tool] Dialog Box (dump850) ...	297
11 - 1	[Object Analysis Tool] Dialog Box (dis850) ...	317
12 - 1	[Static performance analyzer] Dialog Box (cxref) ...	336
12 - 2	[Cross reference Option] Dialog Box ...	340
13 - 1	[Static performance analyzer] Dialog Box (rammap) ...	372
13 - 2	[RAM map option] Dialog Box ...	375
13 - 3	[Object Analysis Tool] Dialog Box (rammap) ...	378
14 - 1	Windows and Dialog Boxes of stk850 ...	386
14 - 2	Function Icons for stk850 ...	390
14 - 3	Project File Related Upper Limit Values ...	397
14 - 4	Intermediate Assembly Language File Related Upper Limit Values ...	397
14 - 5	Stack Size Specification File Related Upper Limit Values ...	397
14 - 6	Output File Related Upper Limit Values ...	398
14 - 7	Stack Size Related Limit ...	398
14 - 8	Upper Limit Values in Message Display Area ...	398
14 - 9	Description for Each Parameter ...	399
14 - 10	Output Format and Content of Adjustment Information ...	400
14 - 11	Description for Each Parameter ...	402
A - 1	Constituent Elements of ELF Header and Their Meanings ...	407
A - 2	Constituent Elements of Program Header Table Entries and Their Meanings ...	408
A - 3	Constituent Elements of Section Header Table Entries and Their Meanings ...	409
A - 4	Section Types and Their Meanings ...	410
A - 5	Meanings of Link and Info ...	410
A - 6	Constituent Elements of Symbol Table Entries and Their Meanings ...	411
A - 7	Relationship Between Indexes and Character Strings in String Table ...	412
A - 8	Reserved Sections ...	413
B - 1	Formats of Messages Output by stk850 ...	493
B - 2	[Do you want to stop reading?] Dialog Box ...	494

CHAPTER 1 OVERVIEW

1.1 Features of Compiler Package

The C compiler package for the V850 microcontrollers contains the following programs.

1. [C COMPILER](#) (ca850)
2. [ASSEMBLER](#) (as850)
3. [LINKER](#) (ld850)
4. [ROMIZATION PROCESSOR](#) (romp850)
5. [HEXADECIMAL CONVERTER](#) (hx850)
6. [ARCHIVER](#) (ar850)
7. [SECTION FILE GENERATOR](#) (sf850)
8. [DUMP COMMAND](#) (dump850)
9. [DISASSEMBLER](#) (dis850)
10. [CROSS REFERENCE TOOL](#) (cxref)
11. [MEMORY LAYOUT VISUALIZATION TOOL](#) (rammap)
12. [STACK USAGE TRACER](#) (stk850)
13. LINK DIRECTIVE GENERATOR (LDG)

These programs can be activated in either of the following ways.

- (1) Activating from integrated development environment "PM+"

"PM+" is included in the C compiler package.

For details of PM+, refer to PM+ User's Manual.

- (2) Activating from command line

Activate the C compiler package by inputting a command in response to the command prompt.

To generate a load module file by using a batch file or make file, describe the module in the command input format. Utilities 8 to 11 above can also be activated by inputting a command.

For details on command input methods, refer to the section "Operation Method" for the respective tool.

The package configuration is as shown below when PM+ is used.

Figure 1 - 1 Package Configuration

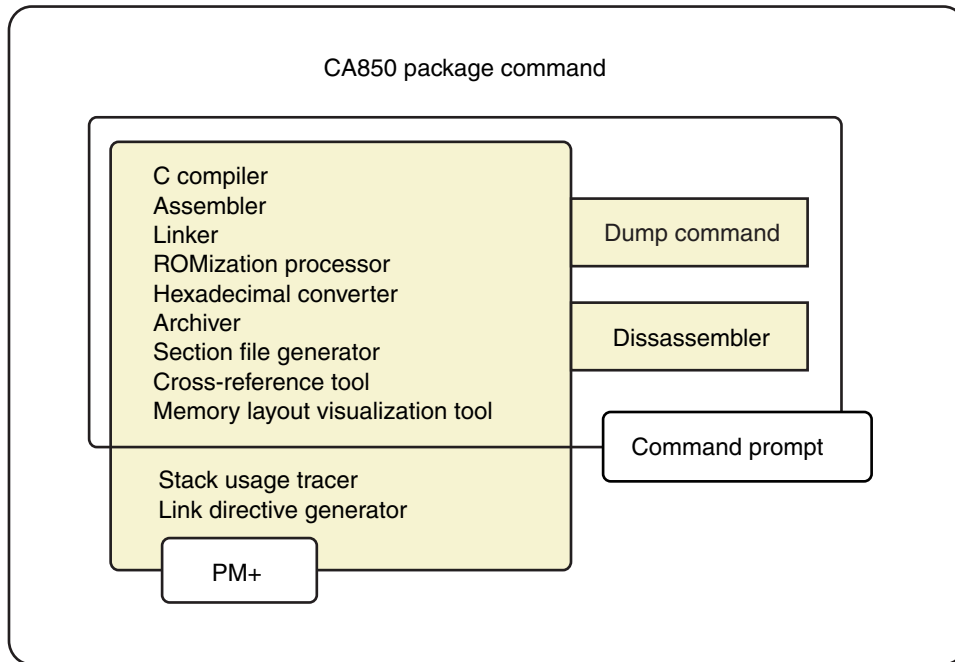

Specify the options of the C compiler, assembler, linker, and so on that are included in the "CA850 package commands" above on the relevant windows from PM+. PM+ automatically activates these commands and creates a load module file.

To use the CA850, a device file that has device information is necessary. Obtain the device file corresponding to the device to be used.

1.2 Operating Environments

The Windows version C compiler package operates under the following environments.

(1) Host machine

- CPU: Pentium II™ 400MHz or higher
- Memory: 128 M bytes or more
- OS: Windows® 2000, Windows XP Professional, Windows XP Home Edition

Caution Regardless of which OS is used, higher and the latest Service Pack must be installed.

(2) Related development tools

- Integrated debugger
ID850 (Ver.3.10 or later), ID850NW (Ver.3.10 or later), or ID850QB (Ver.3.10 or later)
- System simulator
SM850 (Ver.3.00 or later), or SM+ for V850 (Ver.2.00 or later)
- Performance analysis tuning tool
TW850 (Ver.2.10 or later)
- Real-time OS
RX850 (Ver.3.20 or later), RX850 Pro (Ver.3.20 or later)
- Task debugger
RD850 (Ver.3.20 or later), RD850 Pro (Ver.3.20 or later)
- System performance analyzer
AZ850 (Ver.3.30 or later)
- Device file installer
DFINST (Ver.3.10 or later)

Caution To use the CA850, a device file which includes the device information is required.

Download the device file of target device to be used from the following web site:

<http://www.necel.com/micro/ods/eng/index.html>

CHAPTER 2 INSTALLATION

This chapter describes the installation and uninstallation of the CA850.

2.1 Installation

To use the CA850, both the CA850 itself and the related device files must be installed.

To use PM+, PM+ must also be installed.

Install the CA850 as follows.

The supply medium is one CD-ROM.

- (1) Start Windows.
- (2) Insert the CD-ROM into the CD-ROM drive.
The setup program starts up automatically. If the setup program does not start, start Windows Explorer, and double-click "Install.exe" in the CD-ROM drive.
- (3) Select the tool to be installed (CA850, PM+, STK850, LDG, etc.), and specify the folder in which the tool is to be installed. Then, click the [Install] button
- (4) Execute installation in compliance with the messages displayed on the screen.

Note Install the device file in compliance with the device file installer (DFINST) that has been installed.

2.2 Folder Organization

Figure 2 - 1 shows the organization of the file folder that is read from the supply medium when the CA850 is installed.

Below is the CA850's standard folder (default).

```
C:\Program Files\NEC Electronics Tools\CA850\Vx.xx
```

In the CA850 package, the lib850 folder shown in Figure 2 - 1 is called the standard folder for the library, and the inc850 folder is called the standard folder for include files.

Below is the standard folder for the device files (default).

```
C:\Program Files\NEC Electronics Tools\DEV
```

Figure 2 - 1 Folder Organization

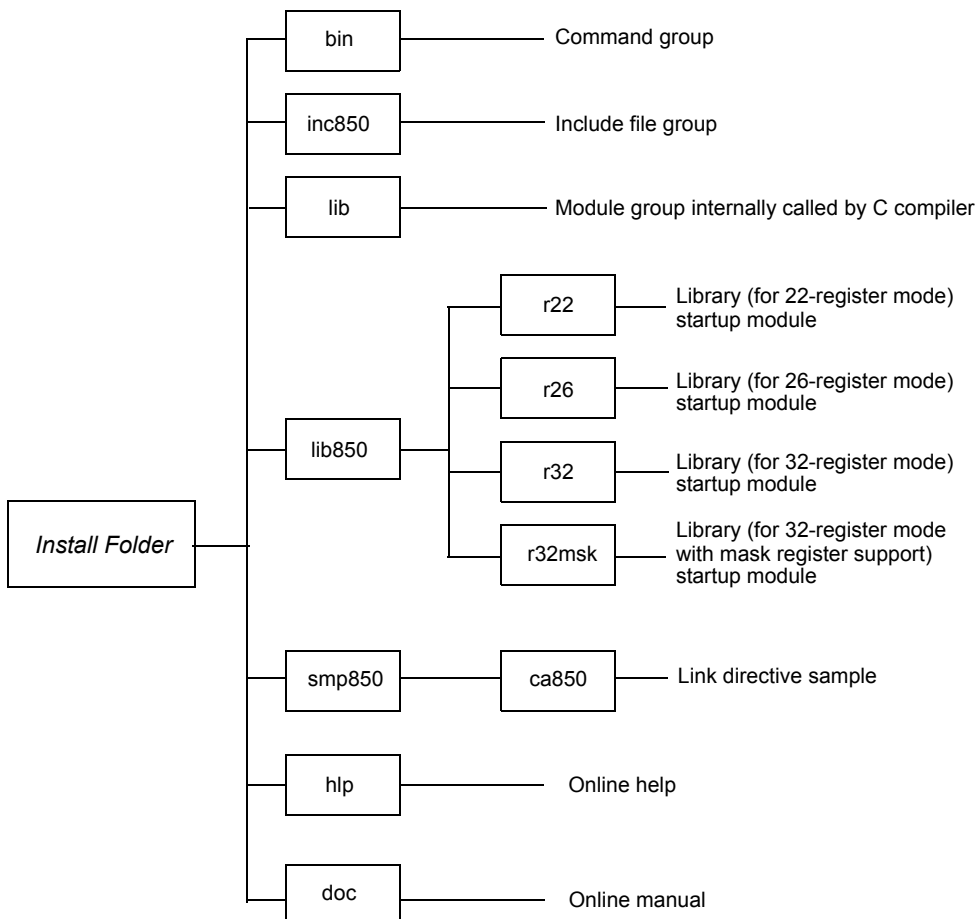

2.2.1 Folder organization of stack usage tracer

Figure 2 - 2 shows the organization of the file folder that is read from the supply medium when the stack usage tracer is installed.

Below is the standard folder for the stack usage tracer (default).

```
C:\Program Files\NEC Electronics Tools\STK850\Vx.xx
```

Figure 2 - 2 Folder Organization of Stack Usage Tracer

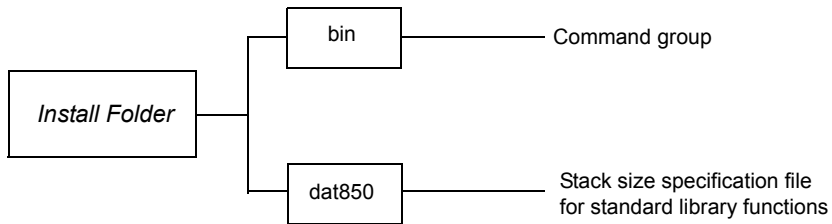

2.3 Uninstallation

This section describes the method for uninstallation of the CA850.

- (1) Start Windows.
- (2) Start "Add or Remove Programs" ("Add/Remove Programs" in Windows other than Windows XP) on the Control Panel of Windows
- (3) Select the following items.
 - NEC EL CA850 Vx.xx
 - NEC EL CA850 Vx.xx Documents

Remark Other tools (PM+, STK850, LDG, etc.) and documents can be uninstalled in a similar way.

CHAPTER 3 C COMPILER

This chapter provides an overview and explains the operation and output messages of the C compiler (ca850).

3.1 Flow of Operation

The ca850 creates relocatable object files and object files executable on the target system from C language source programs described in C language source files.

The ca850 acts as the driver of the modules included in the package and performs operations such as macro expansion, comment processing, merging of intermediate-language files, optimization, creation/conversion from assembly-language source programs to machine language instructions, and linking of object files.

The ca850 performs processing in the following sequence^{Note} (refer to [Figure 3 - 1](#)).

Note As is shown in [Figure 3 - 1](#), the processing flow varies slightly depending on the specified optimization level.

- (1) The front end (cafe) performs macro expansion and comment processing of a C language source program and then converts the program into an intermediate-language OPTIC program.
- (2) The pre-optimizer (popt) rearranges the functions in the intermediate-language OPTIC program.
If this command is activated from the command line, and if "File merging option (-Om)" is specified, two or more intermediate-language OPTIC programs are merged into one. If "Level 2 Advanced option (Exec. Speed)" is specified, inline expansion is performed for the functions in the intermediate-language OPTIC program.
- (3) The global optimization module (opt) optimizes the intermediate-language OPTIC program.
- (4) The code generation module (cgen) converts the intermediate-language OPTIC program into an assembly-language source program.
- (5) The machine-dependent optimization module (impr) optimizes the assembly-language source program.
- (6) The assembler (as850) converts the assembly-language source program into machine language instructions and creates a relocatable object file.
- (7) The linker (ld850) links the relocatable object file, and creates an executable object file.

The machine-dependent optimization module are called only when the optimization option is specified (refer to [Figure 3 - 1](#)). It is assumed that the modules of (1) front end (cafe) through (5) machine-dependent optimization module (impr) are started from the ca850. Consequently, operation is not guaranteed if any of these modules is started alone.

Figure 3 - 1 Operation Flow of ca850

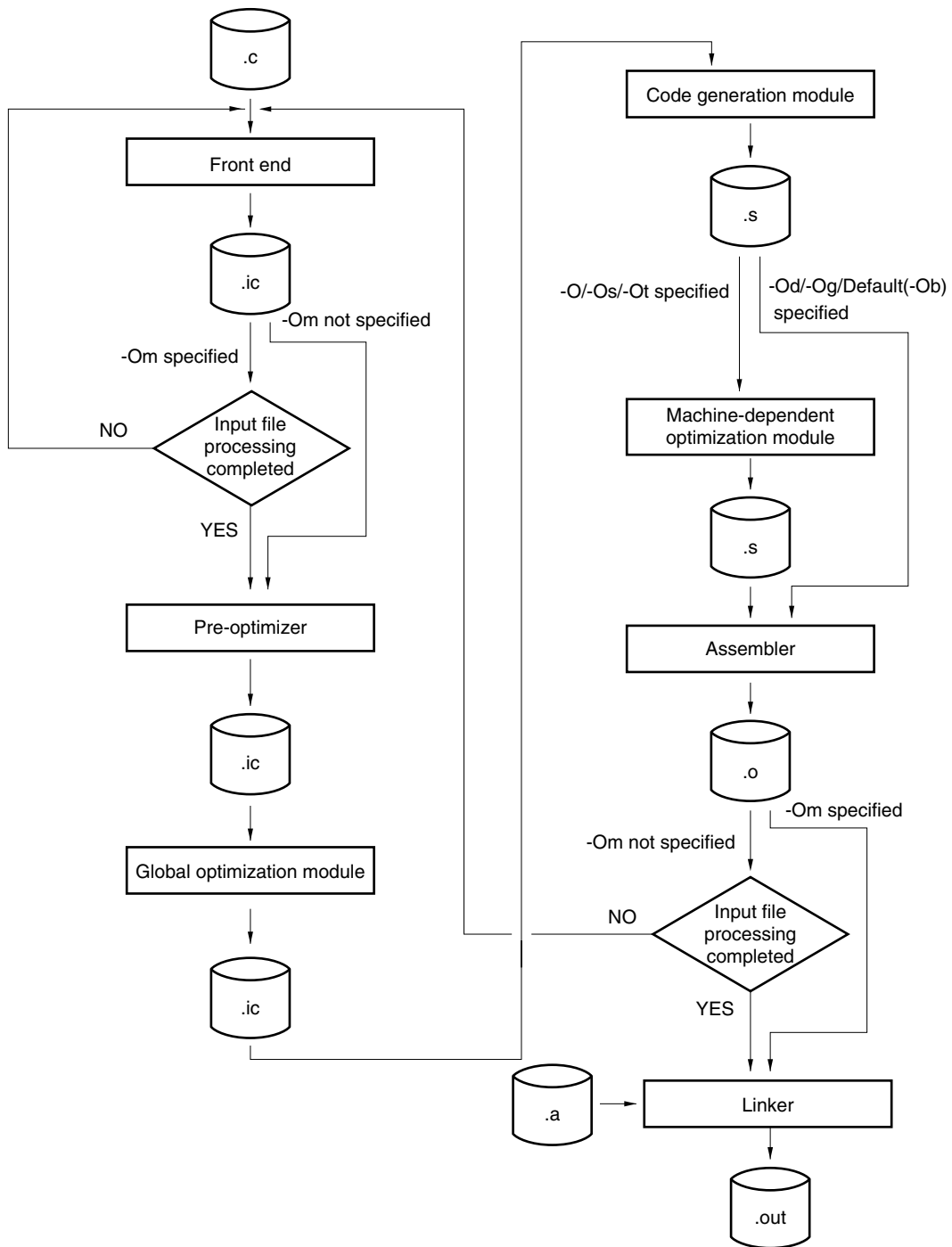

3.2 Input/Output Files

The ca850 can specify the following files as input files or output files.

<i>file.c</i>	C language source file	called the .c file
<i>file.ic</i>	OPTIC file	called the .ic file
<i>file.s</i>	assembly language source file	called the .s file
<i>file.o</i>	object file	called the .o file
<i>file.a</i>	archive file	called the .a file

- The .s file is passed to the as850 (assembler) without modification (a source program directly coded in assembly language does not go through the machine-dependent optimization module).
- All the files other than .c, .ic, and .s files, such as .a and .o files, are all passed as is to the ld850

Caution The input file names supported by Windows can be specified, but "@" cannot be used at the head of a file name because it is regarded as a command option. If the Kanji code of the file is EUC, a file name, folder name, or folder name in Japanese cannot be used.

3.3 Executable Object

The ca850 can read a C language source file and create an executable object file at the same time since it starts both the as850 and the ld850.

In addition, processing can be stopped before the as850 and the ld850 are started by specifying the (-S) command line option and or by specifying single source compilation via PM+. Either of these methods can be used to output a compiler code or to create a relocatable object file (refer to "3.4 Operation Method" for details of these methods).

Examples of starting commands from command line are shown below (refer to "3.5 Types and Features of Options" for details of the command line options).

(1) When executing everything from the ca850

```
> ca850 -cpu 3201 file.c obj.o
```

This specifies "-cpu 3201" (V850ES/SA2) as the device and reads *file.c* and *obj.o* to create an executable object file a.out. At this time, crtE.o is linked as the startup module and the standard libraries libc.a and libm.a are referenced.

```
> ca850 -cpu 3201 -R org_crt.o file.c obj.o
```

This reads *file.c* and *obj.o* to create an executable object file a.out. At this time, org_crt.o is linked as the startup module and the standard libraries libc.a and libm.a are referenced.

(2) When starting from the ca850 to the as850, and starting the ld850 alone

```
> ca850 -cpu 3201 -c file.c asm.s
```

This reads *file.c* and *asm.s* to create the relocatable object files *file.o* and *asm.o*.

```
> ld850 -cpu 3201 org_crt.o file.o asm.o obj.o -lc
```

This links *org_crt.o*, *file.o*, *asm.o*, and *obj.o* to create the executable object file a.out. At this time, libc.a is referenced.

(3) When starting the ca850, the as850, and the ld850 by themselves

```
> ca850 -cpu 3201 -c file.c
```

This reads *file.c* to create the relocatable object file *file.o*.

```
> as850 -cpu 3201 asm.s
```

This reads *asm.s* to create the relocatable object file *asm.o*.

```
> ld850 org_crt.o file.o asm.o -lc
```

This links *org_crt.o*, *file.o*, and *asm.o* to create the executable object file *a.out*. At this time, *libc.a* is referenced.

3.4 Operation Method

This section explains how to operate the ca850.

3.4.1 Command input method

Enter the following from the command prompt.

```
ca850 [option] ... file name [file name or option] ...  
[ ] : Can be omitted  
... : Pattern in proceeding [ ] can be repeated.
```

3.4.2 Method using PM+

The [\[Compiler Options\] dialog box](#) that is used to set compiler options for the C language source files can be displayed via either of the following methods once a project has been established under PM+.

- Set for all C language source files of the target project
 - (1) Select [Tool] - [Compiler Options...].
- Set for a specific C language source file
 - (1) Select the name of the source file to be set a option in the [Project] window on the PM+.
 - (2) Select [Individual Compiler Options...] item that is displayed by clicking the right mouse button.

3.5 Types and Features of Options

The following table lists the ca850 options.

When starting from the command line, if an option that is not listed in the following table is given, that option is regarded as an ld850 option and is passed to the ld850 without modification.

Some options listed below are not included in the PM+'s option dialog box. When one of these options must be specified, activate the ca850 from the command line.

[Symbols used in option list]

[V850E2]	Option dedicated to V850E2 core
[V850E]	Option dedicated to V850Ex core
[PM+]	Option exists as specification item under the PM+.
[78K-compatible]	Option compatible with 78K microcontrollers C compiler CC78Kx

3.5.1 Version/help display/operation status

Version/help display/operation status options are shown below.

-v

This option outputs ca850's version information to standard error output. It does not execute compilation.

-help

This option outputs an option description to standard error output.

-v

[PM+]

This option outputs the execution status of the ca850 to the standard error output in detail.

3.5.2 Output file specification

This section describes the options that specify an output file.

-Fic [=outfile]

This option specifies where an OPTIC file generated during compilation is to be saved.

- (a) If the file name is specified as *outfile*
Saves the *outfile* to the current folder under the specified file name.
The extension of *outfile* is restricted to ".ic"
- (b) If the folder is specified as *outfile*
Saves the *outfile* under a file name with extension .c replaced by .ic to the specified folder.
- (c) If =*outfile* is omitted
Saves the *outfile* under a file name with extension .c replaced by .ic to the current folder.
- (d) If two or more files are output
Creates a folder specified for *outfile*, and saves the OPTIC file under a file name with extension .c replaced by .ic.

-Fo [=outfile]

This option specifies where an object file generated in the middle of compiling is to be saved.

- (a) If the file name is specified as *outfile*
Saves the *outfile* to the current folder under the specified file name.
- (b) If the folder is specified as *outfile*
Saves the *outfile* under a file name with extension .c or .s replaced by .o to the specified folder.
- (c) If =*outfile* is omitted
Saves the *outfile* under a file name with extension .c or .s replaced by .o to the current folder.
- (d) If two or more files are output
Creates a folder specified as *outfile*, and saves the object file under a file name with extension .c or .s replaced by .o.

-Fs [=outfile]

[PM+]

This option specifies where an assembly language file generated in the middle of compiling is to be saved.

- (a) If the file name is specified as *outfile*
Saves the *outfile* to the current folder under the specified file name.
- (b) If the folder is specified as *outfile*
Saves the *outfile* under a file name with extension .c replaced by .s to the specified folder.
- (c) If =*outfile* is omitted
Saves the *outfile* under a file name with extension .c replaced by .s to the current folder.
- (d) If two or more files are output (this cannot be specified with PM+)
Creates a folder specified as *outfile*, and saves the object file under a file name with extension .c replaced by .s.

-Fv [=outfile]

[PM+]

This option specifies whether an assemble list generated in the middle of compiling is to be saved.

- (a) If the file name is specified as *outfile*
Saves the *outfile* to the current folder under the specified file name.
- (b) If the folder is specified as *outfile*
Saves the *outfile* under a file name with extension *.c* or *.s* replaced by *.v* to the specified folder.
- (c) If *=outfile* is omitted
Saves the object file under a file name with extension *.c* or *.s* replaced by *.v* to the current folder.
- (d) If two or more files are output (this cannot be specified with PM+)
Creates a folder specified as *outfile*, and saves the *outfile* under a file name with extension *.c* or *.s* replaced by *.v*.

If this option and the *-a* option are not specified, an assemble list will not be generated.

-o outfile

This option specifies an output file as *outfile*. It is valid even if compiling is stopped midway by specifying the compiler control option *-S*, *-c*, or *-m*.

- (a) If this option is specified with the *-S* option
An assembler file (*.s*) is specified.
- (b) If this option is specified with the *-c* option
A relocatable object file (*.o*) is specified.
- (c) If this option is specified with the *-m* option
A front-end output file (*.ic*) is specified.
- (d) Other than above
An executable object file (*.out*) is specified.
- (e) The default assumption is *a.out*.
An error occurs.

-temp=dir

[PM+]

This option specifies the work folder for creating temporary files that are used internally. If this option is omitted, temporary files are generated in a folder specified by environmental variable *TEMP* or a root folder in the current drive.

If the capacity of the hard disk runs short and a temporary file cannot be generated, an error occurs. This error can be avoided by using this option.

3.5.3 Controlling source debugger

The following options are used to control the source debugger.

`-Xno_word_bitop`

[PM+]

This option prohibits replacing the `ld.w/ld.h` and `st.w/st.h` instructions with 1-bit manipulation instructions (`set1`, `clr1`, `tst1`, and `not1`). If a read/write event of a variable is set during debugging, an event may not be generated if these instructions are replaced by 1-bit manipulation instructions. If this option is specified in such a case, the `ld.w/ld.h` and `st.w/st.h` instructions are not replaced by 1-bit manipulation instructions, making debugging easy.

`-g`

[PM+]

This option outputs symbol information for the source debugger. When the `as850` is started via the `ca850`, specification of this option is regarded as the same as specifying the `as850`'s `"-g"` option. As a result, assembly language source debugging is performed by the debugger.

3.5.4 Control of compile driver

Control of compile driver options are shown below.

(1) Options related to device specification

-x256M

[V850E] [PM+]

This option treats the memory space as 256 M bytes. If this option is not specified, address resolution is performed, assuming that the memory space is 64 M bytes. Set this option in accordance with the chipset to be used.

The physical address space of the V850Ex core has 256 M bytes in many cases. When creating an application that uses a space between 64 M bytes and 256 M bytes, specify this option.

-Xbpc=num

[PM+]

This option sets the higher address of the programmable peripheral I/O register. In *num*, specify only the part of address from which the highest bit of the BPC register is removed.

If the target device has programmable peripheral I/O register functions (such as V850E/IA1), the value must be determined when compiling (assembling) the application to set the variable address portion (= value set in BPC register). Thus, specifying this option compiles (assembles) using the specified value.

When specifying this option, be sure to specify a value. A binary, octal, decimal, or hexadecimal number can be used for the value. If an invalid value is specified, or if a value outside the range that can be set in the BPC register is specified, a warning message is output and this option is ignored.

Example

```
-Xbpc=0x1234
```

In the above case, if the target device is the V850E/IA1, the start address of the programmable peripheral I/O register area is treated as this value shifted 14 bits to the left, or 0x48d0000.

One value is set for an entire application. If you specify "-Xbpc" or "-bpc" when setting options by file, make the values the same between files. However, this option need not be specified for files that do not use the programmable peripheral I/O register.

If this option is specified for a target device that does not have programmable peripheral I/O register functions or when assembling as a common for V850 core/V850Ex core/V850E2 core, a warning message is output and this option is ignored.

This option is for determining the address of the programmable peripheral I/O register when compiling (assembling) and does not actually cause a value to be reflected in the BPC register. For operation, it is necessary to set a value in the BPC register separately using a startup module or the like. A sample appears (commented out) in the startup module included in the package.

Example

For the V850E/IA1, specify the following descriptions in the startup module to make the variable portion of the start address of the programmable peripheral I/O register "0x1234" and set the flag 0x8000 that enables the use of this function.

```
mov0x9234, r10 -- 0x1234 | 0x8000 = 0x9234
st.hr10, BPC
```

The as850 outputs a .bpc section in the special reserved sections when the programmable peripheral I/O register is referenced, regardless of whether this option is specified or omitted. This section is used for checking when linking. The .bpc section is a special reserved section for information and is never loaded into memory. Therefore, it need not be specified in a link directive like a normal section.

-cn

This option embeds the magic number of common to V850 core into the object to be generated.

For further description of magic numbers, refer to "[4.7.1 Magic number](#)".

-cnv850e**[V850E]**

This option embeds the magic number of common to V850Ex core into the object to be generated.

-cnv850e2**[V850E2]**

This option embeds the magic number of common to V850E2 core into the object to be generated.

-cpu *devicename*

This option specifies the target device^{Note}. When using PM+, this is equivalent to specifying the device on the [Project Information] of the [Project Settings] wizard. If this option is omitted and nothing has been specified by the **-cn** option, **-cnv850e** option, **-cnv850e2** option or **#pragma** directive, compilation is stopped.

Note This has the same function as "**#pragma cpu *devicename***". There are two methods: specification by the **-cpu** option or specification by the **#pragma** directive. If both are specified but have different contents, the specification by the **-cpu** option has priority.

-devpath=*dir*

This option searches a device file from the folder *dir*. Only the standard folders are searched if this option is omitted. When using PM+, the device file's installation folder is automatically set, so there is no need to be aware of this option.

(2) Compiler control specification options

-s

This option outputs the generated assembly language source program without executing any modules under the as850. The output file uses .s as the extension instead of .c. If this option is omitted, modules following the as850 are also executed. However, modules under the as850 are also executed if this option has been specified via PM+. To avoid executing those modules, compile source files one at a time.

-a

This option outputs an assemble list to a file whose extension .c is changed to .v (refer to "[4.6 Assemble List](#)"). When the -Og, -O, -Os, or -Ot option is specified, a part of the assemble list may be incorrectly output due to instruction rearrangement for optimization by the as850.

By using this option (-Fv option) with PM+, a file name on the assemble list can be specified.

-c

This option outputs the object file without starting the ld850. The file name extension is .o instead of .c or .s. The ld850 is started if this option is omitted. When PM+ is used, this option is automatically specified for all compilation.

-m

This option simply executes the front end, generates an .ic file, then terminates processing. If this option is omitted, modules after the front end are also executed.

(3) ROMization control option

-Xr

[PM+]

This option is necessary when creating an object for ROMization, and starts up the ROMization processor after link processing. The created object file (default name: romp.out) is the file with the ROMization information.

The compiler processing is as follows.

- (a) The label of the first argument for `_rcopy` specifies the first address (aligned according to the four-byte alignment condition) that exceeds the end of the .text section in the object.
- (b) Consequently, this specifies the area securing code for the rompsec section (default name: rompsec.o) and the libr.a file to be linked by the linker (ld850).

Refer to "[6.4 Creating Object for ROMization](#)" for details of ROMization object creation methods.

(4) Preprocessor processing setting options**-C****[PM+]**

The -C option includes source program comments in a C language source program's preprocessing output. This option is valid only when either the -E option or the -P option has been specified.

-Dname [=def]**[PM+]**

When this option is specified, it is assumed that `#define name def` is entered before the C language source program. If the `=def` specification is omitted, the `def` value is regarded as 1. Up to 256 of this options can be specified.

-E

This option executes preprocessing only for a C language source program and outputs the results to standard output. The results include the line numbers and file name of the source program.

-Idir**[PM+]**

This option searches the folder `dir` and the standard folder, in that order, for the header file of a C language source program. Up to 100 of this option can be specified. If this option is omitted, only the standard folder is searched.

The standard folder is the install folder `\inc850` folder. If `#include "header file name"` is described, the folder where the source file is stored is searched first.

-P

This option executes preprocessing only for a C language source program and outputs the results to a file whose name is the C language source file name plus `.i` as the extension instead of `.c`.

The source program's line numbers and file name are not output.

-Uname**[PM+]**

When this option is specified, it is assumed that `#undef name` is coded before the C language source program. Up to 256 of this options can be specified.

-Wa, -Dname [=num]**[PM+]**

When this option is specified, it is assumed that `.set name, num` is entered before the assemble source.

If the `=num` specification is omitted, the `num` value is regarded as 1.

-Wa, -I, dir**[PM+]**

This option searches the folder `dir` and the standard folder, in that order, for the header file of an assembly language file. If this option is omitted, only the standard folder is searched.

-Xcxxxcom

[PM+]

In addition to ordinary comments, this interprets all characters that appear after `"/"` and before the end of the line as comments (C++ comment style).

-Xd

This option outputs a warning message in response to initialization of a pointer type external variable which uses a variable address that is not an automatic variable or which uses a function address.

-Xmnum

[PM+]

This option specifies an upper limit for the number of macro identifiers. A decimal value up to 32767 can be specified as *num*. A default value of 2047 is used if this option is omitted.

This option increases the size of the buffer used by the preprocessor. However, this option cannot be used to set a specific value for buffer size in terms of the number of characters the buffer can contain.

-t

[PM+]

This option replaces a trigraph sequence.

This option specifies a three-character (trigraph) string to be replaced by a single character defined by the ANSI standard. For details, refer to the documents related to the ANSI standard.

(5) Options to save memory during compilation

-Wp, -D

[PM+]

This option reduces memory in pre-optimizer phase during compiling.

Specify this option if compiling is not completed correctly because the memory of the machine runs short.

The compilation speed drops when this option is specified.

-Wi, -D

[PM+]

This option reduces the memory capacity used in the machine dependent optimization phase during compiling. Specify this option if compiling is not completed correctly.

The compilation speed drops when this option is specified.

(6) Error output specification options**+err_file=file**

This option adds and saves error messages to the file *file*. With PM+, specifying a file name as "Error File" on the [File] in the [Compiler Common Options] dialog box is equivalent to specifying this option.

-err_file=file

This option overwrites and saves error messages to the file *file*.

-err_limit=num**[PM+]**

This option specifies the maximum number of error message to be output, *num*.

Specify 15 to 50 in decimal numbers as *num*. If this option is omitted, 15 is assumed.

(7) Expansion function specification option**-cc78k****[78K-compatible] [PM+]**

This option enables the expansion functions compatible with the 78K microcontrollers C compiler CC78Kx.

3.5.5 Optimization

"Optimization" is processing used to increase the execution speed of an application or to decrease the ROM capacity to be used. How optimization is performed differs depending on the level of optimization. If a high level of optimization is selected, the compilation speed may slow down and the probability of allocating C language source lines to be deleted or changed and variables to registers increases. In the latter case, phenomena such as being unable to set breakpoints with the debugger may occur, and the debugging efficiency may be affected.

For details of optimization, refer to "[3.7.3 Efficient use of optimization](#)".

(1) Optimization options

-od

[PM+]

Optimize for Debugging option

This option generates codes emphasizing logic debugging, without putting stress on the ROM capacity and execution speed. Its function is equivalent to the default optimization of CA850 Ver. 2.41 or earlier.

-Ob

[PM+]

Default Optimization option

This option generates codes emphasizing logic debugging. It executes optimization within a range where logic debugging is not affected

-Og

[PM+]

Standard Optimization option

This option executes appropriate optimization. It executes optimization that allows debugging of the C language source in most cases. Because external variables are assigned to registers, both the execution speed and code size are improved from those of the default option.

-O

[PM+]

Level 1 Advanced Optimization option

This option executes optimization emphasizing the ROM capacity.

-Os

[PM+]

Level 2 Advanced (Object Size) option

This option executes the maximum optimization placing the utmost emphasis on the ROM capacity.

-Ot

[PM+]

Level 2 Advanced (Exec. Speed) option

This option executes the maximum optimization placing the utmost emphasis on the execution speed rather than on the ROM capacity.

(2) Target code optimization options**-wi, -O4****[PM+]**

This option strictly analyzes the data flow and executes the most advanced optimization. Specify this option, in addition to the optimization option -O, -Os, or -Ot, to execute more advanced optimization.

Specifically, this option executes optimization as follows.

- Optimization of registers extending over a branch instruction
- Optimization of absolute value operations
- Optimization of a cmp instruction extending over a branch instruction
- Optimization of a return instruction extending over a branch instruction

Depending on the source, the result may be the same as that of -Os or -Ot. The compiling time is longer than that of -Os or -Ot.

-wi, -P**[PM+]**

This option prevents optimization that allows branch destination labels to be aligned. This option can reduce the size of the execution code. It is useful when the Level 2 Advanced option (Exec. Speed) -Ot is specified.

(3) File merging option**-Om**

When two or more files are specified at the same time, this option merges the files. The compiling speed will drop, but the optimization application range of such as optimization between functions can be expanded by specifying this option together with the optimization option -O, -Os or -Ot.

However, source debugging will become difficult.

(4) Inline expansion optimization control options**-Wp, -Gnum****[PM+]**

This option limits the stack size of a function in an intermediate language subject to inline expansion to size *num*, and does not execute inline expansion of a function larger than *num*. For *num*, refer to the description of the **-Wp,-I[=file]** option below. If this option is not specified, it is assumed that -Wp,-G32 is specified.

-Wp, -Nnum**[PM+]**

Restricts the intermediate language size for a function subject to inline expansion by the *num* value specification so that inline expansion is not performed for any value larger than the *num* value.

Refer to the **-Wp,-I[=file]** option's description below with regard to the range of *num* values.

-Wp,-N128 is assumed as the specification if this option is omitted and Level 2 Advanced option (Exec. Speed) is specified, otherwise -Wp,-N24 is assumed as the specification.

-Wp, -S

[PM+]

This option unconditionally executes inline expansion of a static function that is referenced only once.

-Wp, -l [=file]

[PM+]

This option outputs function information to standard output or additional output to the *file*. It serves as a guide to the value to be specified by the *-Wp,-Gnum* and *-Wp,-Nnum* options above.

For example, a function called is expanded inline if the function requires stack size equal to or less than the value specified by *-Wp,-Nnum*. If the function has code size equal to or less than the value specified by *-Wp,-Nnum*, it is expanded inline.

Note that the stack size output by this option is the size in intermediate language output by the pre-optimizer and is different from the stack size actually used by the function.

-Wp, -inline

[PM+]

This option executes inline expansion of only a function for which `#pragma inline` is specified. When *-Ot* is specified, the compiler automatically identifies the function and executes inline expansion. Specify this option to expand only the function specified by the user.

-Wp, -no_inline

[PM+]

This option suppresses inline expansion of all functions, including the function for which `#pragma inline` is specified. It is useful for suppressing all inline expansion functions when *-Ot* is specified.

-Wp, -r [funcname]

This option deletes unnecessary functions from the functions called from an entry function, *funcname*, after expansion. Specify *funcname* by prefixing `'_'` to a function described in C. If *funcname* is not specified, it is assumed that `"_main"` is specified.

The function that is called only by an assembler statement is deleted as an unnecessary function because the calling is not recognized. Interrupt functions and real-time OS tasks are not included as functions subject to deletion.

For the relationship between inline expansion and option, refer to CA850 for C Language User's Manual.

(5) Loop expansion optimization control options**-Wo, -Ol [num]****[PM+]**

This option expands a loop *num* times using `for` and `while`. This option can be specified only for "Level 2 Advanced option (Exec. Speed)".

The loop is converted into execution of a loop that is executed *N* times (*N* is a constant) and execution of a loop that includes a code expanded *num* times. If the code size after expansion is too great or if the number of times of execution of the loop is too few, the number of times of expansion may decrease, or the loop may not be expanded at all. In addition, a loop having a complicated structure, such as having inner loops, may not be expanded. If 0 or 1 is specified as *num*, expansion is suppressed^{Note}. If *num* is not specified, it is assumed that 4 is specified. Specify *num* in decimal numbers.

Example

To expand a loop that is executed 10 times four times	
<pre>i = 0; while(i < 10) { /* Processing */ ++i; }</pre>	<pre>i = 0; /* Processing */ i = 1; /* Processing */ i = 2; while(i < 10) { /* Processing */ ++i; /* Processing */ ++i; /* Processing */ ++i; /* Processing */ ++i; }</pre>

Note This option is useful when loop expansion does not need to be performed with "Level 2 Advanced option (Exec. Speed)" specified.

-Wo, -Xlo**[PM+]**

This option expands a loop by fixing the number of times of expanding the loop to the value specified by `-Wo,-Olnum`.

(6) strcpy, strcmp expansion option**-xi****[PM+]**

This option sets a four-byte alignment condition for arrays (including character strings) and structures and expands strcpy() or strcmp() function calls to inline. This speeds up the object's execution but it also increases the code size. This option executes conversion only when the second argument of strcpy() or strcmp() is a character string. In addition, the program requires four-byte alignment of the first argument (the ca850 aligns the second argument since it is a character string).

This option must not be specified together with the -Xpack option.

(7) External variable sort options**-Wo, -Op [=file]****[PM+]**

This option rearranges external variables allocated to a section other than const/sconst sequentially, starting from the largest alignment size. If the intermediate file *file* is specified, the definition and temporary definition of variables in the source file allocated to a section other than const/sconst having external linkage are moved to file. After being moved, the definition and temporary definition of the source file are treated in the same manner as declaration. An error does not occur even if *file* does not exist at the beginning.

(8) Branch instruction control option**-Wo, -XFo****[PM+]**

This option arranges and outputs branch instructions, giving priority to the code size. However, it makes source debugging difficult. This option is valid when the -Og, -O, -Os, or -Ot option is specified. If this option is omitted, a code giving priority to debug information is output for a branch instruction.

3.5.6 Generation code control

Generation code control options are shown below.

(1) Register use control options

-rnum=sym

[PM+]

By using the `-rnum` option, an external variable can be allocated to a register. Specify a register other than the mask register that is vacated by specifying the `-reg` option. Specify an external variable using a symbol name, excluding "_".

The following external variables must not be specified.

- volatile variable
- Variable using address operator "&"
- Structure
- Array
- Internally coupled variable (static)
- Peripheral I/O register

The definition (temporary definition) and declaration of the specified external variable are deleted.

To use the default value of an external variable (if initialization is not executed at the beginning of program execution), assign a default value to a register using the startup file.

-regn

[PM+]

This option limits the number of registers used by the ca850 as n registers (n = register mode).

The specifiable range of values for n are:

Table 3 - 1 Register Mode

Register Mode (n)	Working Registers	Registers for Register Variables
22	r10 - r14	r25 - r29
26	r10 - r16	r23 - r29
32	r10 - r19	r20 - r29

This option cannot be set independently for each source file, and is always used for all files. Since the settings by this option are also recognized by the linker, a library of the appropriate mode is referenced.

32 (32-register mode) is specified if this option is omitted.

By specifying this option, the register mode of the software register bank function can be changed.

-Xmask_reg**[PM+]**

This option specifies use of the mask register function.

When this function is used, the ca850 outputs codes, assuming that an 8-bit mask value, 0xff, is set to r20 and a 16-bit mask value, 0xffff, is set to r21. Mask values must be set to the mask registers (r20 and r21) by a user program such as the startup routine.

With the V850 microcontrollers, byte data and halfword data are sign-extended to word length, depending on the value of the most significant bit, when they are loaded from memory to registers. Consequently, the mask code of the higher bits may be generated when an operation on unsigned char or unsigned short type data is performed. When the result of an operation is stored in a register variable, a mask code is generated for unsigned byte data and unsigned halfword data to clear the higher bits. In both the cases, generation of the mask code can be avoided if word data is used. If word data cannot be used and a mask code is generated, the code size can be reduced by using the mask register function.

To decide whether the mask register function is to be used or not, the following points must be thoroughly considered.

- Is it a program that outputs many mask codes?
- Two register variable registers are used as mask registers: Does this have any effect?

If an object that uses a mask register and an object that does not use a mask register exist together when this option is specified, the ld850 outputs an error.

In the 32 register mode, -mask_reg is passed to the ld850. As a result, the standard library is searched by the linker first in the mask register folder (lib850/r32mak) and then the standard folder.

For the mask register function, refer to CA850 for C Language User's Manual.

(2) Prologue/epilogue runtime option**-Xpro_epi_runtime [=on | =off]****[PM+]**

This option specifies whether or not to perform prologue/epilogue processing based on runtime library function calls. If this option is on, prologue/epilogue processing of the function is performed based on run-time library function calls. If neither [=on] or [=off] is specified, specification of [=on] is assumed. This option is set to on if an optimization option other than the "Level 2 Advanced option (Exec. Speed) [-Ot]" is specified as the optimization type of the "Optimization and Debug Information" option, or by default, and is set to off if [=off] is specified or the -Ot option is specified.

(3) Variable placement control options**-Gnum****[PM+]**

Data that is less than *num* bytes is allocated to the `.sdata` section or the `.sbss` section.

If this option is omitted, all data is allocated to the `.sdata` section or the `.sbss` section.

However, any data that is specified for an `.sdata` or `.sbss` section in a `#pragma` section directive or a section file (refer to "9.1 Section Files") is allocated to the `.sdata` or `.sbss` section regardless of the data size. Specify a decimal number as the *num* value. The range of values that can be specified as *num* is output by the ld850's "-A" option. For details of the `#pragma` section directive, refer to CA850 for C Language User's Manual .

-Xsconst [=num]**[PM+]**

This option allocates `const` attribute data and character string literal to the `.sconst` section.

If *num* has been specified, data whose size is *num* bytes or less is allocated to the `.sconst` section and if *num* has been omitted, allocation is performed regardless of the data size. Specify a decimal number as the *num* value. If a different option is specified for each file, a code of a different method of placing and referencing variables may be generated and an error or warning may be output during linking (a different option cannot be specified for each file with PM+).

-Xcre_sec_data [=outfile]**[PM+]**

This option outputs a variable frequency data file used by the section file generator.

- (a) If the file name is specified as *outfile*

Saves the *outfile* to the current folder under the specified file name.

- (b) If the folder is specified as *outfile*

Saves *outfile* to a specified folder, with extension `.c` replaced by `.sec`.

- (c) If *=outfile* is omitted

Saves the file to the current folder, with extension `.c` replaced by `.sec`.

- (d) If two or more files are output

Creates a folder specified as *outfile*, and saves the files with extension `.c` replaced by `.sec`.

When several C language source files exist, and a frequency data file is to be created with a file name specified for each file, PM+ opens the option dialog box for each C language source file from the source file list and then specifies a file name when the frequency data file is created. When using command line input, it specifies this option with *=outfile* for each C language source file. The C language source files are specified one at a time (with `-c` specified). The variable frequency data file outputs information how often the ld850 or st instruction accesses variables in the C language source file. Nothing is performed on the assembly language source file. When this option and the `-Xcre_sec_data_only` option are simultaneously specified, the `-Xcre_sec_data_only` option takes priority.

-Xcre_sec_data_only [=outfile]

This option outputs the variable frequency data file used by the section file generator. However, unlike the `-Xcre_sec_data`, this option outputs only the variable frequency data file and does not perform object generation. This is used when outputting only the frequency data file.

- (a) If the file name is specified as *outfile*
Saves the *outfile* to the current folder under the specified file name.
- (b) If the folder is specified as *outfile*
Saves the *outfile* under a file name with extension `.c` replaced by `.sec` to the specified folder.
- (c) If `=outfile` is omitted
Saves the *outfile* under a file name with extension `.c` replaced by `.sec` to the current folder.
- (d) If two or more files are output
Creates a folder specified as *outfile*, and saves the object file under a file name with extension `.c` replaced by `.sec`.

When several C language source files exist, and a frequency data file is to be created with a file name specified for each file, PM+ opens the option dialog box for each C language source file from the source file list and then specifies a file name when the frequency data file is created. When using command line input, it specifies this option with `=outfile` for each C language source file. The C language source files are specified one at a time (with `-c` specified). The variable frequency data file outputs information how often the `ld850` or `st` instruction accesses variables in the C language source file. Nothing is performed on the assembly language source file.

-Xsec_file=file**[PM+]**

This option specifies the name of the section file (refer to "9.1 Section Files") that is used to specify section allocation of data when the C language compiler is activated. Be sure to specify this file name.

This option can be specified several times and several section files can be input.

(4) Signed/unsigned control option**-xbitfield=string****[PM+]**

This option specifies whether specifications in int type bit fields that do not indicate the type specifier (signed or unsigned) are regarded as signed or unsigned specifications.

The following can be specified as *string*.

s	Handled as signed
signed	Handled as signed
u	Handled as unsigned
unsigned	Handled as unsigned

A warning message is output when the specification is handled as unsigned. The specification is handled as signed if this option is omitted.

-xchar=string**[PM+]**

This option specifies whether char type specifications that do not indicate the type specifier (signed or unsigned) are regarded as signed or unsigned specifications.

The following can be specified as *string*.

s	Handled as signed
signed	Handled as signed
u	Handled as unsigned
unsigned	Handled as unsigned

The specification is handled as signed if this option is omitted.

-xenum_type=string**[PM+]**

This option specifies which integer type the enumeration type matches.

The following can be specified as *string*.

char	Treated as char
uchar	Treated as unsigned char
short	Treated as short
ushort	Treated as unsigned short

If this option is omitted, the enumeration type is treated as signed int.

(5) Switch-case statement output code control options**-Xcase=string****[PM+]**

This option specifies a mode in which the code of a switch statement is to be output. As *string*, the following can be specified.

ifelse	Outputs the code in the same format as the if-else statement along a string of case statements. If the case statements are written in the order of frequency or if only a few labels are used, select this option. Because the case statements are compared starting from the top, unnecessary comparison can be reduced and the execution speed can be increased if the case statement that most often matches is written first.
binary	Outputs the code in the binary search format. Searches for a matching case statement by using a binary search algorithm. If this option is selected when many labels are used, any case statement can be found at almost the same speed.
table	Outputs the code in a table jump format. A table indexed based on the value of a case statement is referenced and a case label is selected depending on the value of the switch statement. Execution branches to any case statement at almost the same speed. If case values are not used in succession, an unnecessary area is created.

If this option is omitted, the compiler automatically selects the optimum format.

-Xword_switch**[PM+]**

This option creates one four-byte branch table per case label in a switch statement. Specify this option to prevent compile errors that would otherwise occur when the switch statement is long.

Two-byte branch tables are generated if this option is omitted.

(6) Structure packing control options**-Xbyte****[PM+]**

This option specifies indirect address access to a structure in byte units.

Use this option if a limit is exceeded when the structure packing function is used.

-Xpack=num**[PM+]**

By using this option, the specified alignment can be used without aligning structure members in accordance with the type of each member. The data size can be reduced but the code size increases.

1, 2, 4, or 8 can be specified as num.

The default value is 8^{Note}.

If this option is specified if structure packing is specified by the #pragma directive in the C language source, the value specified by this option is applied to all structures until the first #pragma directive appears. After that, the value of the #pragma directive is applied. Even after the #pragma directive has appeared, however, the value specified by the option is applied if the default value is specified. This option must not be specified with -Xi option. Note the following when using this option.

- (a) If -Xpack option is specified when structure packing is specified by the #pragma directive in the C language source, the value specified by the option is applied to all structures until the first #pragma pack directive appears. After that, the value of the #pragma directive is applied. Even after the #pragma directive has appeared, however, the value specified by the option is applied if the default value is specified.

This option has following restrictions, when using the V850 core/V850Ex core/V850E2 core that is set to disable misalign access. These restrictions are the same as for #pragma pack.

- (a) The address of a structure member cannot be obtained correctly.
- (b) Accessing a bit field also accesses a data field because the type of the member is read. If the width of the bit field is less than the type of the member, the outside of the object is accessed because the type of the member is read. Usually, no problem with execution occurs, but an illegal access may be made if I/O is mapped.

For details of structure packing, refer to CA850 for C Language User's Manual.

Note With this version, the operation when the value of num is "4" is the same as that when it is "8".

(7) Far jump output control options

`-Xfar_jump=file`

`-Xfar_jump file`

[PM+]

The `jmp` directive is used to branch (jump) to the function specified in *file*.

The `ld850` outputs an error if the function is in a range that cannot be branched to by the `jarl` or `jr` directive, in which case this option is used to recompile. The file name space cannot be left blank. A extension is necessary for a file name. The extension ".fjp" is recommended.

This option must not be specified to call a function at the flash side from the boot side by using the Flash/external ROM re-link function. For details, refer to "[5.6 Flash Memory/External ROM Relink Function](#)".

`-xj`

[PM+]

This option uses the `jmp` instruction to perform a branch for an ordinary interrupt function defined in C language. If the number of functions is in the range that cannot be branched by the `jr` directive and the `ld850` outputs an error, this option can be used to recompile. The `jr` instruction is used if this option is omitted.

This option must not be specified to call a function at the flash side from the boot side by using the Flash/external ROM re-link function. For details, refer to "[5.6 Flash Memory/External ROM Relink Function](#)".

(8) Comment output option

`-xc`

[PM+]

This option outputs C language source programs as comments to the assembly language source file to be output. However, the output comments are for reference only and may not correspond exactly to the code. For instance, comments concerning global variables, local variables, function declarations, etc., may be output to incorrect positions. If the code is deleted on the optimization, only the extracted comment may remain.

To use this option, `-S`, `-a`, `-Fs`, or `-Fv` must be specified.

(9) ANSI standard options**-Xe****[PM+]**

This option specifies that runtime library `___mul/___mulu` or `___div/___divu` will be used instead of the `mulh` and `divh` directives for integers corresponding to data that is 16 bits or less.

This option slows the processing speed but strictly complies with the multiplication and division processing under the ANSI standard.

The `mulh` and `divh` directives are used if this option is omitted.

The runtime library of the CA850 is prepared as the standard library of CA850 so that the instructions not provided to the architecture of the V850 microcontrollers satisfy the ANSI standard. For the runtime library, refer to CA850 for C Language User's Manual .

-Xdefvar**[PM+]**

This option handles tentative definition as definition.

-ansi**[PM+]**

This option makes ca850 processing comply with the ANSI standard and outputs an error or warning for a specification that violates the standard. Extended description other than in `_asm` format is recognized.

Specifying this option defines the macro name `__STDC__`. If this option is omitted, compatibility with the conventional C language specifications is conferred and processing continues after warning message is output.

Processing when compiling in strict adherence to the language specification is as follows.

(1) Trigraph sequences

Replaces trigraphs. They are not replaced if this option is not specified.

(2) Bit fields

It is an error if a type other than an `int` type is specified in a bit field. If this option is not specified, a warning may be output and the specification is permitted.

(3) Scope of variables

If an automatic variable of the same name as a function argument is declared, it is a duplicate definition error. If this option is not specified, a warning may be output and the automatic variable is made valid.

(4) Pointer assignment

(a) It is an error if a pointer type numeric value is assigned to a general integer type variable. If this option is not specified, a warning may be output and the pointer is assigned by casting.

(b) It is an error to assign pointers that point to different types. If this option is not specified, a warning may be output and the assignment is permitted.

(5) Type conversion

It is an error to convert a non-left side value array to a pointer. If this option is not specified, a warning may be output and the conversion is permitted.

(6) Comparison operators

Comparison of a pointer to an arithmetic type variable is an error. If this option is not specified, a warning may be output and the comparison is permitted.

(7) Conditional operators

It is an error if the second and third expressions are not both general integer types, the same structure, the same common, or pointer types to the same type of target. If this option is not specified, a warning may be output and the operator is assigned by casting.

(8) #line-number

This is an error. If this option is not specified, #line-number is treated the same way as "#line line-number".

(9) "#" character within a line

This is an error. If this option is not specified, a warning may be output and the "#" character is permitted.

(10) _asm

A warning may be output and -asm is treated as a function call. However, __asm is valid. If this option is not specified, -asm is treated as an assembler insert.

(11) __STDC__

A macro with a value of 1 is defined. If this option is not specified, the macro name is not defined as a macro.

(12) Binary constant

Unusable. If this option is not specified, a string that consists of "0b" or "0B" followed by one or more "0" or "1" is handled as a binary constant.

3.5.7 Library specification

Library specification options are shown below.

-Ldir

This option searches libraries starting in the folder *dir*, then in the standard folder.

Only the standard folder is searched if this option is omitted.

The standard folder is the install folder \lib850 folder and install folder \lib850\r32 folder. If the register mode is specified, however, r22 or r26 folder is searched instead of r32 folder.

Refer to the description of the -L option of the ld850.

-R file

When startup goes as far as the ld850, the startup module to be used is indicated to the ld850 as file.

For details of the startup module, refer to CA850 for C Language User's Manual .

If this option is omitted, crtN.o in the standard folder is used as the startup module. The standard folder is the install folder \lib850\r32 (r26 or r22).

-lstring

This option specifies the archive file that is referenced by the ld850.

Nothing is referenced if this option is omitted. When activating the ld850 from the ca850, however, the ca850 automatically passes the link specification of the standard library (-lc) and mathematical library (-lm) to the ld850.

For how to specify an archive file, refer to the description of the ld850 library specification option (-l).

3.5.8 Warning message control

Warning message control options are shown below.

-wnum

[PM+]

This option specifies the level of warning messages.

The following numbers can be specified as *num*.

0	Suppresses message
1	Outputs ordinary warning message
2	Outputs detailed warning message

The `-w0` specification is assumed if *num* is omitted. The `-w1` specification is assumed if this option is omitted.

-wstring+

-wstring-

This option specifies outputting or suppressing a warning message for each parameter regardless of the level. A warning message is output when "+" has been specified or is suppressed when "-" has been specified.

The following character strings can be specified as *string*.

bitfield_align	When bit field members have exceeded the boundary set by the alignment condition and have been allocated starting from the next boundary
bitfield_type	When a type that cannot be specified in the ANSI specification is specified for the bit field
callnodecl	When calling an undeclared function
nopic	When using a variable address that is not an automatic variable or a function address to initialize a pointer type external variable
pragma	When a non-executable #pragma description appears
sharp	When a sharp symbol (#) appears in a source line

An error occurs if neither "+" nor "-" has been specified. The specification is according to the `-wnum` level if this option is omitted.

-won=num [, num] . . .

-won=num1-num2 [, num3-num4] . . .

[PM+]

This option outputs a warning message of the number specified by *num*. A warning message in the 2000s can be specified as *num*. If *num1-num2* is specified, the warning messages from *num1* to *num2* are specified. The *num* must not be omitted. If a warning number not provided in the CA850 is specified, a warning message is output.

`-woff=num[, num]...`

`-woff=num1-num2[, num3-num4]...`

[PM+]

This option suppresses a warning message of the number specified by *num*. A warning message in the 2000s can be specified as *num*. If *num1-num2* is specified, the warning messages from *num1* to *num2* are specified. The *num* must not be omitted. If a warning number not provided in the CA850 is specified, a warning message is output.

3.5.9 Other

Other options are shown below.

(1) Command file specification option

@cfile

This option handles *cfile* as a command file (refer to "3.7.2 Command file"). Consequently, there is no need to be cognizant of restrictions concerning the option character string length.

For command files, arguments to be specified can be described divided into several lines, but do not divide options, file names, and the like across two lines.

If this option is omitted, it is assumed that no command file has been specified.

(2) CPU bug patch option

-Xv850patch [=num]

This option specifies the `-p[num]` option for `as850` according to the *num* specification for an assembly language source file output by the `ca850` to output a code corresponding to a CPU fault (refer to "4.7.2 Options for avoiding CPU faults").

The specifiable values for *num* are 1, 2, 3, 4, 4a, 5, 6, 7, 8, 9, 10, and 11.

If `=num` has been omitted, "1, 2, 3, 5, 6, 7, 8, 9, 10" is assumed as the *num* specification.

This option is to avoid faults of the CPU. Whether a fault that has occurred is of the CPU used, refer to the documents supplied with the CPU.

Note that only the `-Xv850patch=11` option is processed by the `ca850`. If the `-Xv850patch=11` option is specified, the following instructions are not output.

- `set1`, `clr1`, and `not1`
- Misalign access of V850Ex core/V850E2 core (during structure packing)

If these instructions are used in an `asm` statement and an assembly language source file, they are output as is because `asm` statements and assembly language source files are not checked.

Also, when having specified the `-Xv850patch=11` option and describing bit access to the peripheral I/O register in the program, access to the peripheral I/O register is in word (4-byte) units. Change descriptions to byte/half-word unit operation, not bit access.

CPU core and patch option related to this bug are as follows (for the newest version μ PD70(F)3xxx, not including maintenance or obsolete products).

To check whether or not the failure affects the CPU used, refer to the CPU's documentation.

Table 3 - 2 Correspondence Between CPU Core and -Xv850patch Option for This Bug

CPU Core	-Xv850patch=11
V850 core	---
V850E/MS1	A
V850E1 core	A
V850ES core	A

Remark A : Affected

OK : Corrected (for the newest version μ PD70(F)3xxx, not including maintenance or obsolete products)

--- : Not affected

3.5.10 Option to each module

The ca850 can pass options to each module.

-Wx, option

This option passes option as an *option* for module x. If option includes a comma, the *option* is assigned as multiple options, each delimited by a comma. The following modules can be specified as module x.

p	Pre-optimizer (popt)
o	Global optimization (opt)
i	Machine-dependent optimization (impr)
a	Assembler (as850)
l	Linker (ld850)

(1) Pre-optimizer (popt)**-Wp, -D**

Enables reduction of memory usage at compile time.

-Wp, -Gnum

Restricts the stack size for a function subject to inline expansion by *num* size specification in intermediate language so that inline expansion is not performed for any value larger than the *num* value.

Refer to the **-Wp,-I[=file]** option's description below with regard to the range of *num* values. **-Wp,-G32** is assumed as the specification if this option is omitted.

-Wp, -Nnum

Restricts the intermediate language size for a function subject to inline expansion by the *num* value specification so that inline expansion is not performed for any value larger than the *num* value.

Refer to the **-Wp,-I[=file]** option's description below with regard to the range of *num* values.

-Wp,-N128 is assumed as the specification if this option is omitted and Level 2 Advanced option (Exec. Speed) is specified, otherwise **-Wp,-N24** is assumed as the specification.

-Wp, -S

Unconditionally performs inline expansion for static functions that have been referenced only once.

-Wp, -l [=file]

Outputs function information to standard output or additional output to the *file*. The displayed information includes a range of values to be specified for the **-Wp,-Gnum** and **-Wp,-Nnum** options described above. For example, in the case of stack size, inline expansion is performed if the called function's value is not greater than the value specified for **-Wp,-Nnum**. Note that the stack size output using this option is different from the stack size actually used by functions because it is the size in the intermediate language output by the pre-optimizer.

-Wp, -r [_funcname]

Given the "*funcname*" function as the entry function, this deletes the functions called by this function that are no longer needed after expansion. Enter a "_" at the start of the function name specified in *funcname*.

If *funcname* is omitted, "_main" is assumed as the specification. Functions that are called only by assembly-language programs are not recognized as called functions and are instead deleted as unnecessary functions.

However, interrupt functions and real-time OS tasks are not included as functions subject to deletion.

-Wp, -inline

Executes inline expansion of only the function for which **#pragma inline** is specified.

-Wp, -no_inline

Suppresses inline expansion of all functions including the function for which **#pragma inline** is specified.

(2) Global optimization (opt)**-Wo, -O1 [num]**

This option expands a loop *num* times using `for` and `while`. This option can be specified only for "Level 2 Advanced option (Exec. Speed)".

The loop is converted into execution of a loop that is executed *N* times (*N* is a constant) and execution of a loop that includes a code expanded *num* times. If the code size after expansion is too great or if the number of times of execution of the loop is too few, the number of times of expansion may decrease, or the loop may not be expanded at all. In addition, a loop having a complicated structure, such as having inner loops, may not be expanded. If 0 or 1 is specified as *num*, expansion is suppressed^{Note}. If *num* is not specified, it is assumed that 4 is specified. Specify *num* in decimal numbers.

Example

To expand a loop that is executed 10 times four times	
<pre>i = 0; while(i < 10) { /* Processing */ ++i; }</pre>	<pre>i = 0; /* Processing */ i = 1; /* Processing */ i = 2; while(i < 10) { /* Processing */ ++i; /* Processing */ ++i; /* Processing */ ++i; /* Processing */ ++i; }</pre>

Note This option is useful when loop expansion does not need to be performed with "Level 2 Advanced option (Exec. Speed)" specified.

-Wo, -Op [=file]**[PM+]**

This option rearranges external variables allocated to a section other than `const/sconst` sequentially, starting from the largest alignment size. If the intermediate file *file* is specified, the definition and temporary definition of variables in the source file allocated to a section other than `const/sconst` having external linkage are moved to file. After being moved, the definition and temporary definition of the source file is treated in the same manner as declaration. An error does not occur even if file does not exist at the beginning.

-W_o, -X_{Fo}

[PM+]

Outputs code giving priority to the code size when a branch occurs. However, the debug information will be affected. This option is valid when -Og, -O, -Os, or -Ot is specified. If this option is omitted, a code giving priority to debug information is output when a branch occurs.

-W_o, -X_{lo}

Expands a loop under the condition of the version CA850 Ver. 2.02 or earlier.

(3) Machine-dependent optimization (impr)

-W_i, -D

The amount of memory used at compile time can be reduced.

Note that this may slow down the compilation speed. This is specified if too much memory is used so that the compiler is unable to operate normally.

-W_i, -O4

[PM+]

Strictly analyzes the data flow and executes the following optimization.

- (a) Optimization of register straddling over branch instruction
- (b) Optimization of absolute value operation
- (c) Optimization of cmp instruction straddling over branch instruction
- (d) Optimization of restore instruction straddling over branch instruction

Note that this may slow down the compilation speed. Specify this option if you want data flow analysis anyhow when -O, -Os or -Ot has also been specified.

-W_i, -P

[PM+]

Suppresses optimization that aligns labels. As a result, a smaller code size is enabled.

(4) Assembler (as850)

Refer to "[4.4 Types and Features of Options](#)".

(5) Linker (ld850)

Refer to "[5.3 Types and Features of Options](#)".

3.6 Settings Made via PM+

This section describes the dialog boxes that are used to set the command options of the ca850 for the target project's C language source files.

The [\[Compiler Common Options\] dialog box](#) is used to set the command options commonly used by compilers. It is opened by the following method.

- (1) Select [Tool] - [Compiler Common Options]

The [\[Compiler Options\] dialog box](#) is used to set the ca850 command options for the target project's C source files. After setting the project via the [Project] menu, use either of the following methods to open this dialog box.

- Set for all C language source files of the target project
 - (1) Select [Tool] - [Compiler Options].
- Set for a specific C language source file
 - (1) Select the name of the source file to be set a option in the [Project] window on the PM+.
 - (2) Select [Individual Compiler Options...] item that is displayed by clicking the right mouse button.

When a specific setting has been performed, the general option settings become invalid for that file. For a file for which specific options have been set, the icon at the head of the file name of the source file in the [Project] window changes to green.

To make specific option settings invalid and have general option settings take effect, click the [Individual Compiler Option Release] item that is displayed by clicking the right mouse button, or click the [Delete Source Option] button added to the "[General]", "[Others]" and "[Difference]" tabs in the [\[Compiler Options\] dialog box](#).

The option name displayed in "[]" in each option in the option settings dialog box is the option name for starting from the command prompt. There also are options that can be specified only when starting from the command prompt, such as when an output object name is specified.

To set a mode in which debug information is output, select the "[Generate Debug Information\[-g\]](#)" check box on the [\[Optimization and Debug Information\] tab](#) in the [\[Compiler Options\] dialog box](#).

When the path of an include file is set or changed, select [Build] - [Update Dependencies], and then select [Project] - [Export Makefile].

3.6.1 [Compiler Common Options] dialog box

At the upper part of this dialog box, the following six tabs are displayed.

The contents of this dialog box depend on selecting the following tab.

Table 3 - 3 [Compiler Common Options] Dialog Box

Tab	Description
[File]	Settings related to output files
[Startup]	Settings related to startup file
[Link Directive]	Settings related to link directives
[ROM]	Settings related to ROMization
[Flash]	Settings related to flash memory
[Device]	Setting of options related to device

The following four tabs are displayed for a library creation project.

Table 3 - 4 [Compiler Common Options] Dialog Box (library)

Tab	Description
[File]	Settings related to output files
[ROM] (library)	Settings related to ROMization when library is created
[Flash] (library)	Settings related to flash memory when library is created
[Device]	Setting of options related to device

[File]

This tab is used to make settings related to output files.

Figure 3 - 2 [Compiler Common Options] Dialog Box ([File] Tab)

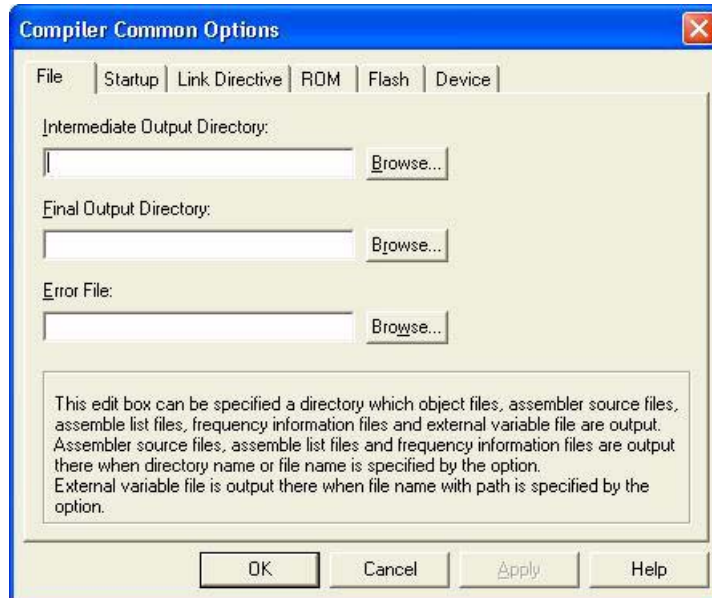

(1) Intermediate Output Directory

This edit box is used to set an intermediate output folder.

The intermediate output folder is a folder to which object files, assembly language source files, assemble list files, frequency information files, and external variable files are output.

(2) Final Output Directory

This edit box is used to set a final output folder.

The final output folder is a folder to which executable object files, hex files, archive files, link map files, error files, and section files are output.

However, if a file name with a path is specified for each option, these files are output there.

(3) Error File

This edit box is used to set a file to which error and warning messages are output.

When this edit box is set, the "+err_file" option is set for all the compiler tools.

[Remark]

If the folder specified as the "Intermediate Output Directory" or "Final Output Directory" does not exist when the [OK] or [Apply] button is clicked, the following message box is displayed to check if a folder is to be created.

Figure 3 - 3 Checking Creation of Folder

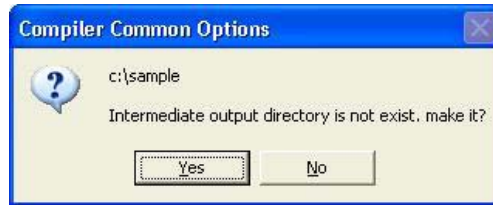

If the [Yes] button is clicked in this message box, a folder can be created.

If no folder is created, options cannot be set.

[Startup]

This tab is used to make settings related to the startup file.

Figure 3 - 4 [Compiler Common Options] Dialog Box ([Startup] Tab)

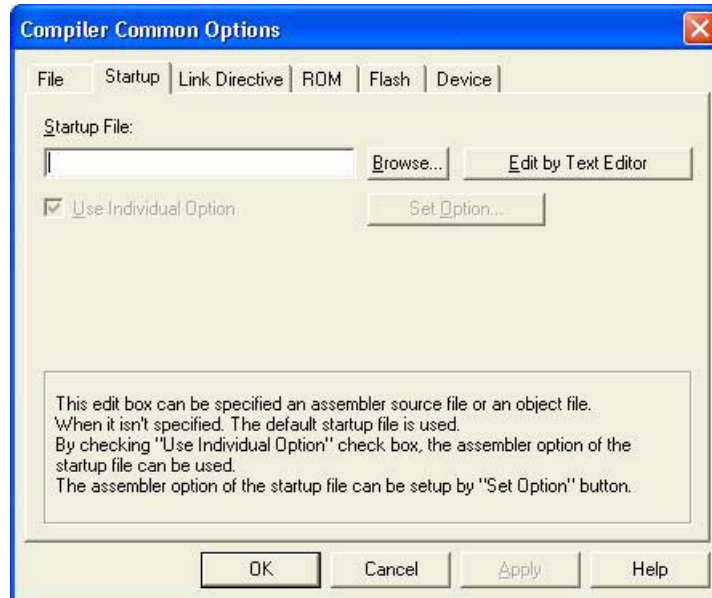

(1) Startup File

This edit box is used to set a startup file.

Set an assembly language source file or object file in this edit box. If a startup file is not set, the default startup file (crtN.o or crtE.o) is used.

An assembly language source file can be edited by using the [Edit by Text Editor] button. Note that a space can be used in a folder name in this dialog box but a space cannot be used in a file name.

(2) Use Individual Option

If this check box is checked, the individual assembler options of a startup file are used.

The assembler options of the startup file can be set by using the [Set Options...] button.

[Link Directive]

This tab is used to make settings related to link directives.

Figure 3 - 5 [Compiler Common Options] Dialog Box ([Link Directive] Tab)

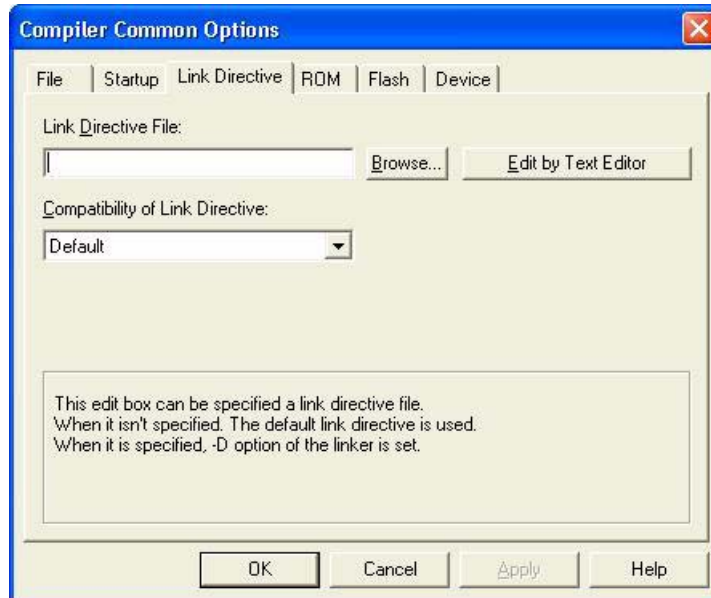

(1) Link Directive File

This edit box is used to set a link directive file.

When a link directive file is set, the -D option is passed to the linker.

The link directive file can be edited by using the [Edit by Text Editor] button

In this edit box, a space can be used in a folder name but not in a file name. If an extension ('.dir' is recommended) is not used in a file name, a warning message indicating that build processing may not be performed correctly is displayed.

(2) Compatibility of Link Directive

This edit box is used to specify compatibility of the link directive with that of a version earlier than CA850 Ver. 2.70.

The following four items can be specified in this edit box.

- Default
- V2.40 or earlier
- V2.50
- V2.60

If a previous version is specified, the "-Xolddir" option is passed to the linker.

Caution "V2.40 or earlier" includes Ver. 2.4x.

[ROM]

This tab is used to make settings related to ROMization.

Figure 3 - 6 [Compiler Common Options] Dialog Box ([ROM] Tab)

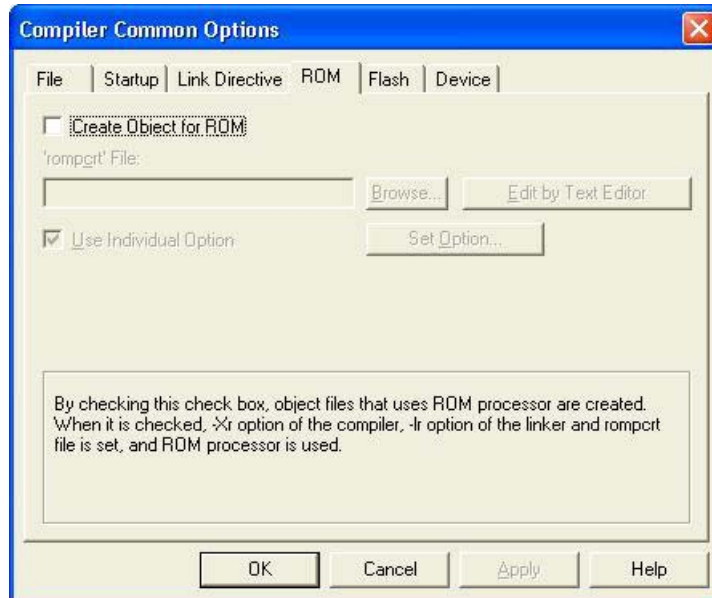

(1) Create Object for ROM

When this check box is checked, an object supported by the ROMization processor is generated.

When this check box is checked, the `-Xr` option is passed to the compiler, the `-lr` option and `rompct` file are passed to the linker, and the ROMization processor is used.

(2) 'rompct' File

This edit box is used to specify the file name of the `rompct` file that is specified when ROMization is performed. If no file name is specified, the default file name (`rompct.o`) is used.

An assembly language source file can be edited by using the [Edit by Text Editor] button. Note that, in this edit box, a space can be used in a folder name but not in a file name.

(3) Use Individual Option

When this check box is checked, an individual assembler option for the `rompct` file is used.

The assembler option of the `rompct` file can be set by using the [Set Option...] button.

[Flash]

This tab is used to make settings related to the flash area.

Figure 3 - 7 [Compiler Common Options] Dialog Box ([Flash] Tab)

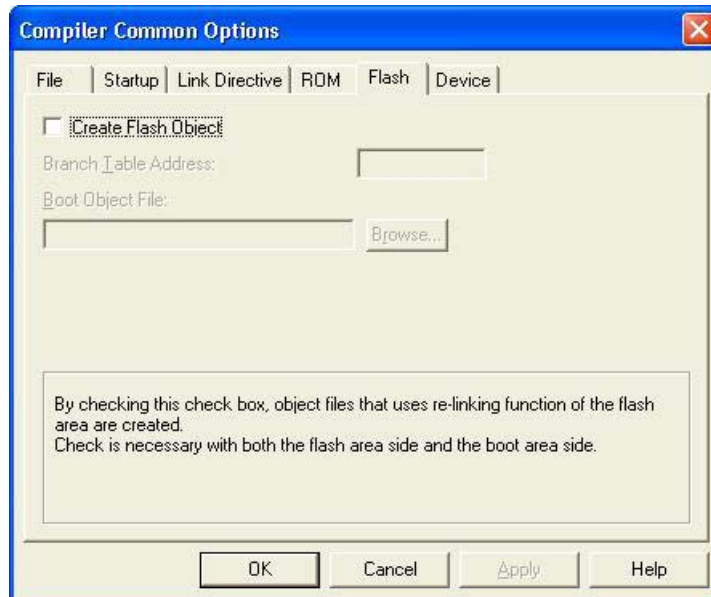

(1) Create Flash Object

When this check box is checked, an object file with a function to relink a flash area is generated.

This option must be specified on the flash area side and boot area side.

For details of objects that support flash area, refer to "[5.6 Flash Memory/External ROM Relink Function](#)".

(2) Branch Table Address

Specify the address from which the branch table is to be allocated in hexadecimal numbers in C language.

The same addresses must be specified for both the flash area and boot area. When an address is specified, the `-ext_table` option is specified for the linker.

(3) Boot Object File

This edit box is used to set a boot object file.

When a boot object file is specified, the `-Wa,-zf` option is passed to the compiler, the `-zf` option is passed to the assembler, and the `-zf` option is passed to the linker.

Note that, in this edit box, a space can be used in a folder name but not in a file name.

[Device]

This tab is used to set options related to the device.

Figure 3 - 8 [Compiler Common Options] Dialog Box ([Device] Tab)

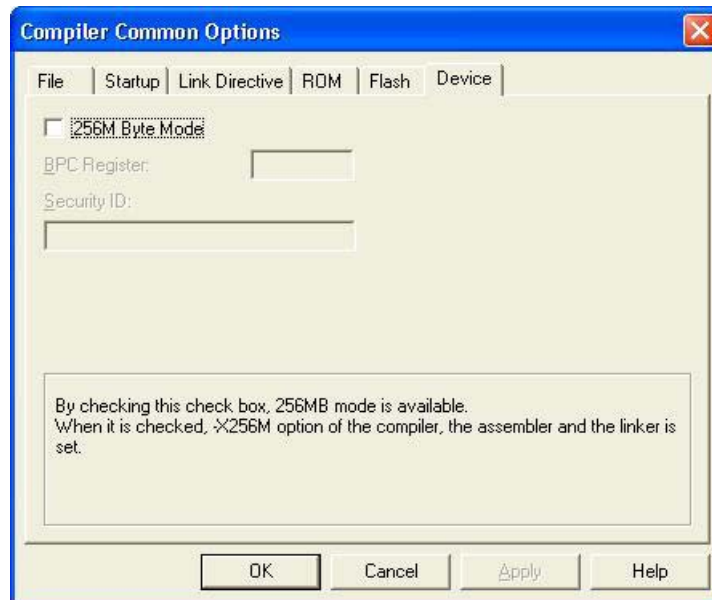

(1) 256M Byte Mode

When this check box is checked, the 256 M bytes mode is specified. When it is checked, the `-X256M` option is passed to the compiler, assembler, and linker.

As a result, the memory space is treated as a 256 M bytes space. If this option is not specified, the memory space is treated as a 64 M bytes space and addresses are resolved.

Set this option in accordance with the chipset to be used. With the V850Ex core, the physical address space has 256 M bytes in many cases. Specify this option when creating an application using a space between 64 M bytes and 256 M bytes.

(2) BPC Register

This box is used to specify the higher address of a programmable peripheral I/O register.

When an address is specified, the `-Xbpc` option is passed to the compiler and the `-bpc` option is passed to the as850. If the target device (such as the V850E/IA1) has a programmable peripheral I/O register function and if an address that can be modified (= value to be set to the BPC register) is set, the value must be determined when the application is compiled (assembled). If this option is used, the application is compiled (assembled) with the specified value.

When specifying this option, be sure to specify a value. A value can be specified in binary, octal, decimal, or hexadecimal numbers. If an illegal value is specified, or if a value exceeding the permissible range of the BPC register is specified, a warning message is output and this option is ignored.

[Example]

```
-Xbpc=0x1234
```

In the above case, if the target device is the V850E/IA1, the start address of the programmable peripheral I/O register area is treated as 0x48d0000, which results from shifting this value 14 bits to the left.

Only one value can be set for the overall application. If "-Xbpc" and "-bpc" are specified as options of each file, the value of the address must be the same among the files. However, this option does not have to be set for a file that does not use a programmable peripheral I/O register. If a target device without a programmable peripheral I/O register function is used or if the application is assembled in common for the V850 core/V850Ex core/V850E2 core, a warning message is output when this option is specified, and this option is ignored.

This option is used to determine the address of a programmable peripheral I/O register when an application is compiled (assembled), and does not reflect the actual value on the BPC register. To execute an operation, a value must be set to the BPC register separately by using the startup module.

Refer to CA850 for C Language User's Manual for a sample of the startup routine. The startup module included in the package also has a (commented) sample.

[Example]

If the part of the start address of the programmable peripheral I/O register that can be modified is "0x1234" when the V850E/IA1 is used, and if the flag "0x8000" that enables use of this function is set, make the following description in the startup module.

```
mov 0x9234,r10 - - 0x1234 | 0x8000 = 0x9234
st.hr10, BPC
```

The as850 outputs the reserved section .bpc if this option is specified or if a programmable peripheral I/O register is actually referenced even if this option is omitted. This section is used for checking while the linker is being executed. The .bpc section is a special section reserved for information, and is not loaded to memory. Therefore, it does not have to be described in the link directive as is the case with a normal section.

(3) Security ID

This edit box is used to set the "security ID" of a flash memory device.

This box cannot be used if a device not supporting the security ID function is used.

Specify the ID in hexadecimal numbers of 10 bytes or less (including 0x at the start). If the specified value runs short of 10 bytes, the higher bits are filled with 0. If 10 bytes are exceeded, an error is output. If an object for a device not supporting the security ID function is specified when the linker is executed, a warning message is output and the specified ID is ignored.

For example, to set the security code "0x112233445566778899aa", enter this value as is in the edit box.

[ROM] (library)

This tab is used to make settings related to ROMization when a library is created.

Figure 3 - 9 [Compiler Common Options] Dialog Box ([ROM] Tab (library))



(1) Create Object for ROM

When this check box is checked, an object supported by the ROMization processor is generated.

When this check box is checked, the -Xr option is passed to the compiler.

[Flash] (library)

This tab is used to make settings related to the flash memory when a library is created.

Figure 3 - 10 [Compiler Common Options] Dialog Box ([Flash] Tab (library))



(1) Create Flash Side Archive File

When this check box is checked, an object file is generated on the flash area side of the flash area relink function.

This check box does not have to be checked when an object is to be generated on the boot area side and when a normal object is used.

For details of flash-supporting objects, refer to "[5.6 Flash Memory/External ROM Relink Function](#)".

3.6.2 [Compiler Options] dialog box

The following 12 tabs are displayed in the upper part of the compiler options setting dialog box.
The contents of this dialog box depend on selecting the following tab.

Table 3 - 5 [Compiler Options] Dialog Box

Tab	Description
[General]	Setting of compiler options often used
[Input File]	Setting of options related to input to compiler
[Preprocessor]	Setting of options related to compiler preprocessing
[C Language]	Setting of options related to C language specifications
[Optimization and Debug Information]	Setting of optimization level in source units and debug information
[Detail of Optimization]	Setting of options related to optimization in phase units
[External Register]	Settings related to external variable registers
[Output File]	Setting of options related to output files
[Output Code]	Setting of options related to output codes
[Message]	Setting of options related to messages
[Assembler]	Setting of options of assembler used when C language source is assembled
[Others]	Other settings

The following 11 tabs are displayed for an individual source option setting.

Table 3 - 6 [Compiler Options] Dialog Box (Individual Source)

Tab	Description
[General]	Setting of compiler options often used
[Preprocessor]	Setting of options related to compiler preprocessing
[C Language]	Setting of options related to C language specifications
[Optimization and Debug Information]	Setting of optimization level in source units and debug information
[Detail of Optimization]	Setting of options related to optimization in phase units
[Output File]	Setting of options related to output files
[Output Code]	Setting of options related to output codes
[Message]	Setting of options related to messages
[Assembler]	Setting of options of assembler used when C language source is assembled
[Others]	Other settings
[Difference]	Indication of differences between the compiler options for the overall C language sources and the individual source options.

[General]

This tab is used to set options that are often used for the compiler.

Figure 3 - 11 [Compiler Options] Dialog Box ([General] Tab)

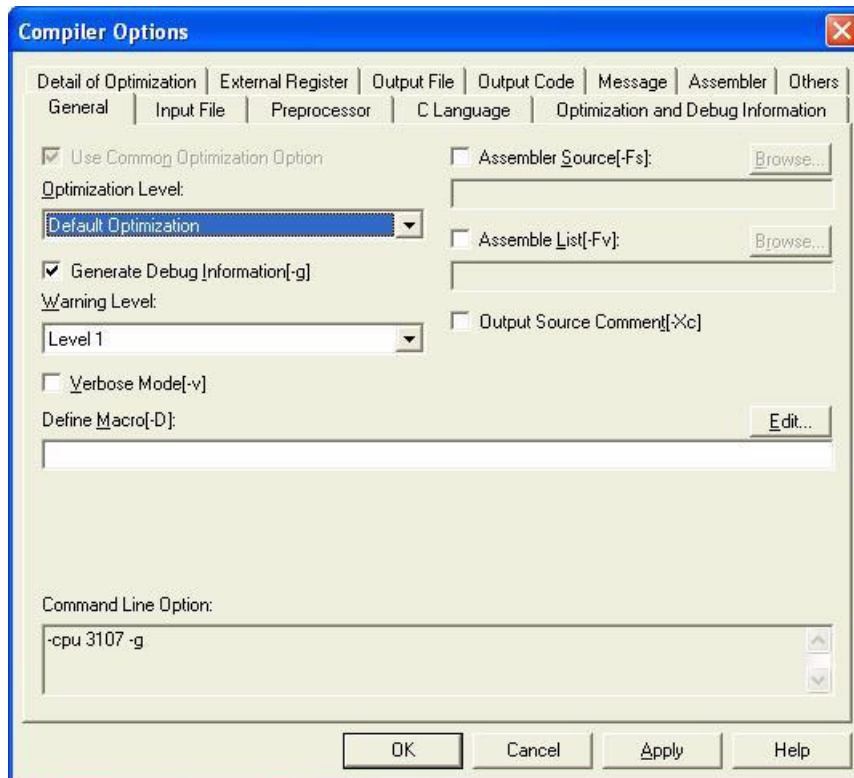

(1) Use Common Optimization Option

This check box is valid when "Individual source option" is set. It specifies whether optimization specified in "Optimization Level" below this check box is used or not as optimization that is performed on individual sources.

If this check box is checked, optimization of the level specified by a global option is applied to the target source. When "Set global option" is specified, this check box is dimmed and cannot be specified.

(2) Optimization Level

Select the optimization level to be used from the drop-down list.

This option is the same as the item set for "Optimization" on the [Optimization and Debug Information] tab.

The following types of optimization can be specified.

- Optimize for Debugging[-Od]

This option generates codes emphasizing logic debugging, without putting stress on the ROM capacity and execution speed. Its function is equivalent to the default optimization of CA850 Ver. 2.41 or earlier.

- Default Optimization

This option generates codes emphasizing logic debugging. It executes optimization within a range where logic debugging is not affected

- Standard Optimization[-Og]

This option executes appropriate optimization. It executes optimization that allows debugging of the C language source in most cases. Because external variables are assigned to registers, both the execution speed and code size are improved from those of the default option.

- Level 1 Advanced Optimization[-O]

This option executes optimization emphasizing the ROM capacity.

- Level 2 Advanced Opt. (Object Size)[-Os]

This option executes the maximum optimization placing the utmost emphasis on the ROM capacity.

- Level 2 Advanced Opt. (Exec. Speed)[-Ot]

This option executes the maximum optimization placing the utmost emphasis on the execution speed rather than on the ROM capacity.

For details of optimization, refer to "[3.7.3 Efficient use of optimization](#)".

(3) Generate Debug Information[-g]

This check box is used to generate debug information. Check this box to debug a program, for example, when a C language source is debugged with the debugger. When this box is checked, the -g option is passed to the compiler.

(4) Warning Level

Select the level of the warning messages to be output from the drop-down list. This option is the same as the item set for "[Warning Level](#)" on the [\[Message\]](#) tab. The following levels of warning messages can be selected.

Not output[-w]	Warning messages suppressed
Level 1	Ordinary warning messages output (default).
Level 2[-w2]	Detailed warning messages output.

(5) Verbose Mode[-v]

This check box is used to display the detailed execution status of the ca850 on the Output window. When this box is checked, execution status in each internal phase of the compiler is displayed. This option is the same as the item set for "[Verbose Mode\[-v\]](#)" on the [\[Message\]](#) tab.

(6) Assembler Source[-Fs]

This check box is used to specify whether an assembly language source resulting from compiling a C language source is output or not. When it is checked, the edit box below this check box can be used to specify a folder name or file name. If a folder name is specified in this edit box as "Setting of global options" and if the specified folder does not exist, a message box asking you if a folder is to be created is displayed. If nothing is specified in the edit box, an assembly language source is output to the project folder with the extension of the C language source file name changed to .s. To specify another output destination, specify a folder name in the edit box.

If a file name is specified for "Setting of global options", an assembly language source for the source compiled last is output because the same file name is overwritten. A file name can be specified when a file name is specified for the individual source options setting. This option is the same as the item set for "[Assembler Source\[-Fs\]](#)" on the [\[Output File\]](#) tab.

(7) Assemble List[-Fv]

This check box is used to specify whether an assemble list resulting from compiling a C language source is output. When it is checked, the edit box below can be used to specify a folder name or file name.

If a folder name is specified in this edit box as "Setting of global options" and if the specified folder does not exist, a message box asking you if a folder is to be created is displayed.

If nothing is specified in the edit box, an assemble list is output to the project folder with the extension of the C language source file name changed to .v. To specify another output destination, specify a folder name in the edit box.

If a file name is specified for "Setting of global options", an assembly language source for the source compiled last is output because the same file name is overwritten. A file name can be specified when a file name is specified for "individual source options".

This option is the same as the item set for "[Assemble List\[-Fv\]](#)" on the [\[Output File\]](#) tab.

(8) Output Source Comment[-Xc]

This check box is used to output a C language source program as a comment to the assembly language source file and assemble list that are output. This option is the same as the item set for "[Output Source Comment\[-Xc\]](#)" of the [\[Output Code\]](#) tab.

(9) Define Macro[-D]

This edit box is used to specify a macro name to be defined, in the form of "macro name = defined value def". If = defined value def is omitted, def is assumed to be 1.

Example

```
test = 2 /* macro "test" is defined as "2" */
```

It is assumed that #define name def is described before a C language source program. To define two or more macros, delimit each with ";" (semicolon). By selecting the [Edit...] button, the [\[Edit Option\] dialog box](#) can be displayed and the defined macro can be edited in this dialog box. Blanks must not be used in a macro name.

This option is the same as the item set for "[Define Macro\[-D\]](#)" on the [\[Preprocessor\]](#) tab.

(10) Command Line Option

This area displays the options set in this dialog box by command line options.

This area is for reference and cannot be written to.

[Button]**(a) [Delete Source Option] button**

This button can be selected when option settings for individual source files have been made, and is not displayed (is dimmed) and cannot be selected when options for the overall project have been specified.

When selected, this button deletes any option specified for a particular source file and applies only global options.

[Input File]

This tab is used to set options related to input to the compiler.

Figure 3 - 12 [Compiler Options] Dialog Box ([Input File] Tab)

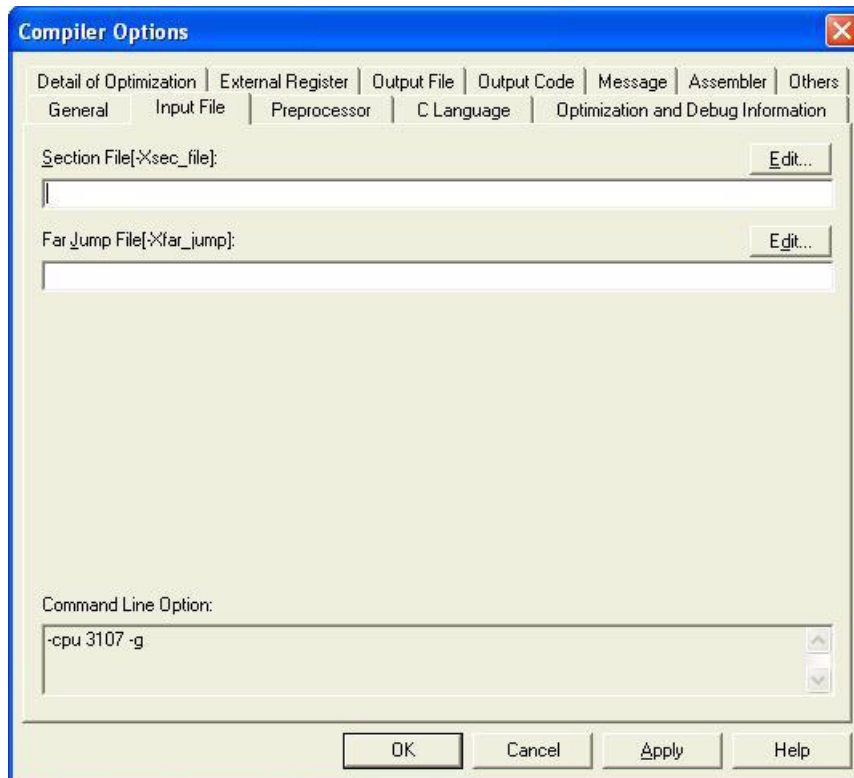

(1) Section File[-Xsec_file]

This specifies a section file name (refer to "[CHAPTER 9 SECTION FILE GENERATOR](#)"). A file name can be set in the text box. A space can be used in a folder name but not in a file name.

Since a section file is divided into several files, use a semicolon (;) to delimit file names when specifying two or more file names. Selecting the [Edit...] button displays the [\[Edit Option\] dialog box](#), where the file name items can be edited.

(2) Far Jump File[-Xfar_jump]

Use the -Xfar_jump option to specify the Far Jump file settings.

The Far Jump file outputs codes using the jmp instruction for the branch instruction of a function described in the file. If the body of the function is in a range to which execution cannot branch by the jarl and jr instructions resulting in an error being output by the ld850, recompile by using this option.

The file name needs an extension. The recommended extension is ".fjp".

A space can be used in a folder name but not in a file name. Selecting the [Edit...] button displays the [\[Edit Option\] dialog box](#) where files can be selected.

(3) Command Line Option

This area displays the options set in this dialog box by command line options.

This area is for reference and cannot be written to.

[Preprocessor]

This tab is used to set options related to the preprocessor.

Figure 3 - 13 [Compiler Options] Dialog Box ([Preprocessor] Tab)

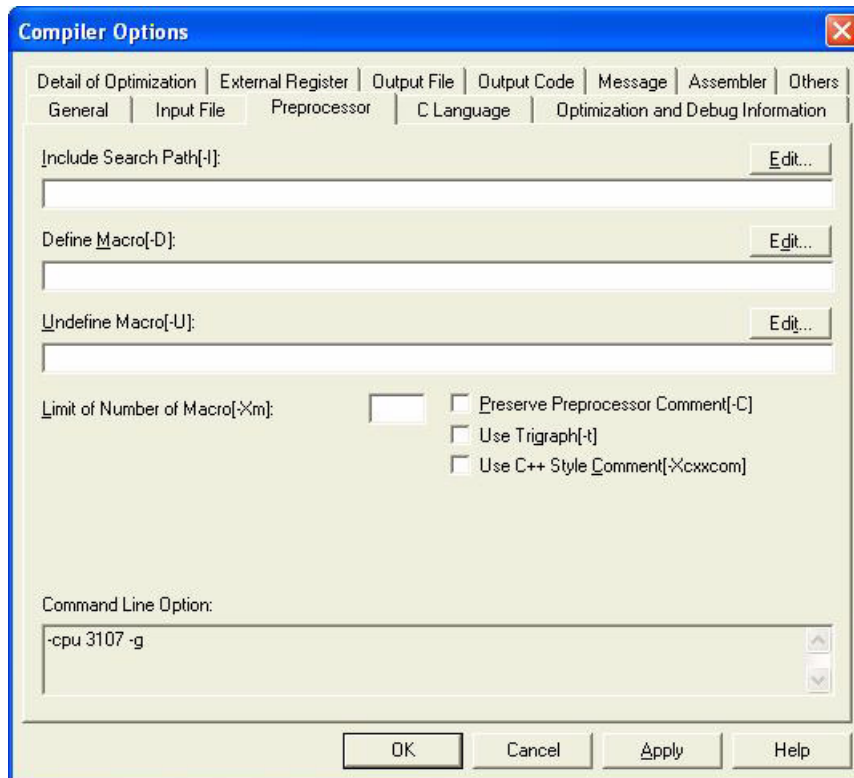

(1) Include Search Path[-I]

This specifies the folders to be searched when searching for header files. The specified folders will be searched before the standard folder is searched. When specifying several paths, use a semicolon ";" to delimit the path specifications. Selecting the [Edit...] button displays the [Edit Option] dialog box, where path items can be edited.

Example

```
.\include;C:\include
```

When this option is omitted, only the standard folder^{Note 1} will be searched^{Note 2}. This option cannot be set independently for each source file, and is always used for all files.

Notes 1 The standard folder is "install folder\inc850".

2 When using the coding format that encloses a file name with ("), the folder where the source file exists is searched first.

(2) Define Macro[-D]

This uses the "macro name name = definition value def" format to define macro names. If the "=definition value def" specification is omitted, a value of 1 is assumed as def.

Example

```
test = 2    /* Macro "test" is defined as "2" */
```

It is assumed that "#define name def" is entered before a C language source program. When specifying several macros, use semicolons ";" to delimit them.

Selecting the [Edit...] button displays the [\[Edit Option\] dialog box](#), where define macro names can be edited.

Spaces cannot be used in the macro name.

(3) Undefine Macro[-U]

Use this to specify macro names to be rendered invalid. It is assumed that "#undef name" is entered before a C language source program. When specifying several macros, use semicolons ";" to delimit them.

Selecting the [Edit...] button displays the [\[Edit Option\] dialog box](#), where undefine macro names can be edited.

Example

```
__3201__    /* Macro "__3201__" is rendered invalid. */
```

Spaces cannot be used in the macro name.

(4) Limit of Number of Macro[-Xm]

This specifies a decimal number of up to 32767 as the upper limit of the number of macro identifiers. The default value is 2047. This option is used to expand the size of the buffer used by the preprocessor. However, a concrete value such as the number of characters secured for the buffer cannot be obtained.

(5) Preserve Preprocessor Comment[-C]

This check box is used to include the comments of the source program in the preprocessing output of a C language source program. This box is valid only when the "Preprocessed Source" on [\[Output File\]](#) tab is specified.

(6) Use Trigraph[-t]

This replaces the trigraph series^{Note}.

Note The trigraph series replaced with a single character, as prescribed in the ANSI standard. Refer to documents related to the ANSI standard.

(7) Use C++ Style Comment[-Cxxcom]

In addition to ordinary comments, this allows any text from "/" to the end of the line to be handled as comments (C++ comment style).

(8) Command Line Option

This area displays the options set in this dialog box by command line options.

This area is for reference and cannot be written to.

[C Language]

This tab is used to set options related to C language specifications.

Figure 3 - 14 [Compiler Options] Dialog Box ([C Language] Tab)

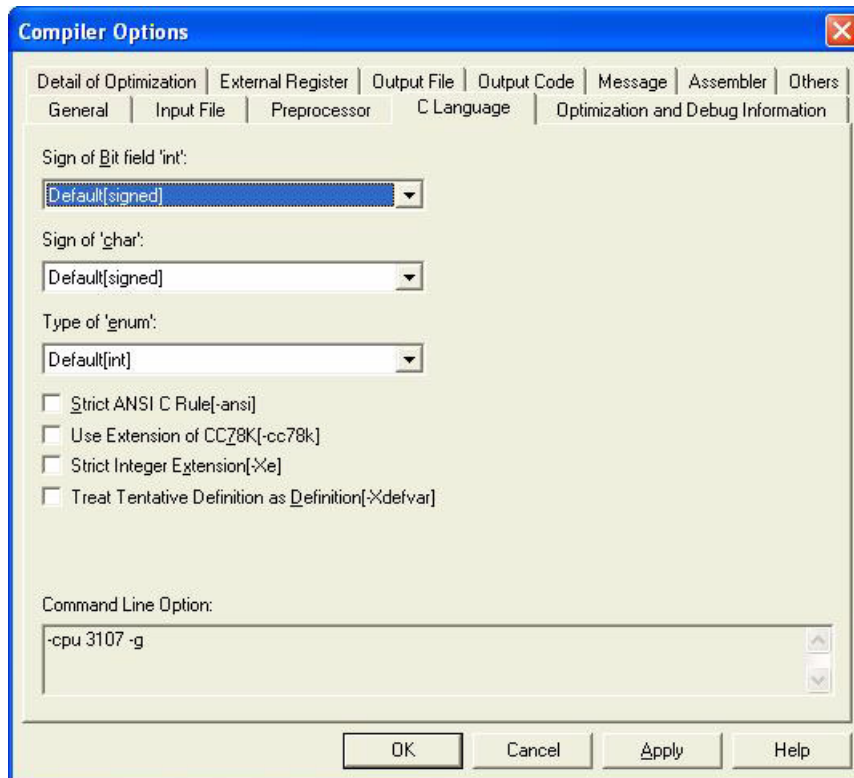

(1) Sign of Bit field 'int'

This area is used to specify the signed or unsigned status of an integer type bit field for which the signed/ unsigned status has not been specified. The default setting is "signed".

(2) Sign of 'char'

This area is used to specify the signed or unsigned status of simple char type for which the signed/ unsigned status has not been specified. The default setting is "signed".

(3) Type of 'enum'

This edit box is used to specify which integer type an enumeration type matches. char, unsigned char, short, unsigned short, and int can be selected. int is assumed by default.

(4) Strict ANSI C Rule[-ansi]

Check this box to compile strictly according to the language specification in the ANSI standards.

(5) Use Extension of CC78K[-cc78k]

This check box specifies whether the expanded language specification of the CC78Kx is valid. If it is checked, the effect is the same as specifying the -cc78k option.

(6) Strict Integer Extension[-Xe]

When this box is checked, `__mul/__mulu` and `__div/__divu` from the runtime library^{Note} are used instead of `mulh` and `divh` directives for integers having data lengths of 16 bits or less.

Multiplication and division are performed strictly according to the ANSI standards, although this slows down the processing speed. If this check box is not selected, the `mulh` and `divh` instructions are used.

Note The runtime library in the CA850 is provided as the ca850's standard library in order to fulfill the ANSI standards with regard to instructions that are not included in the V850 microcontrollers architecture.

For details of the runtime library, refer to CA850 for C Language User's Manual.

(7) Treat Tentative Definition as Definition[-Xdefvar]

When this box is checked, tentative definitions are treated as definitions.

(8) Command Line Option

This area displays the options set in this dialog box by command line options.

This area is for reference and cannot be written to.

[Optimization and Debug Information]

This tab is used to set optimization level in source units and debug information.

Figure 3 - 15 [Compiler Options] Dialog Box ([Optimization and Debug Information] Tab)

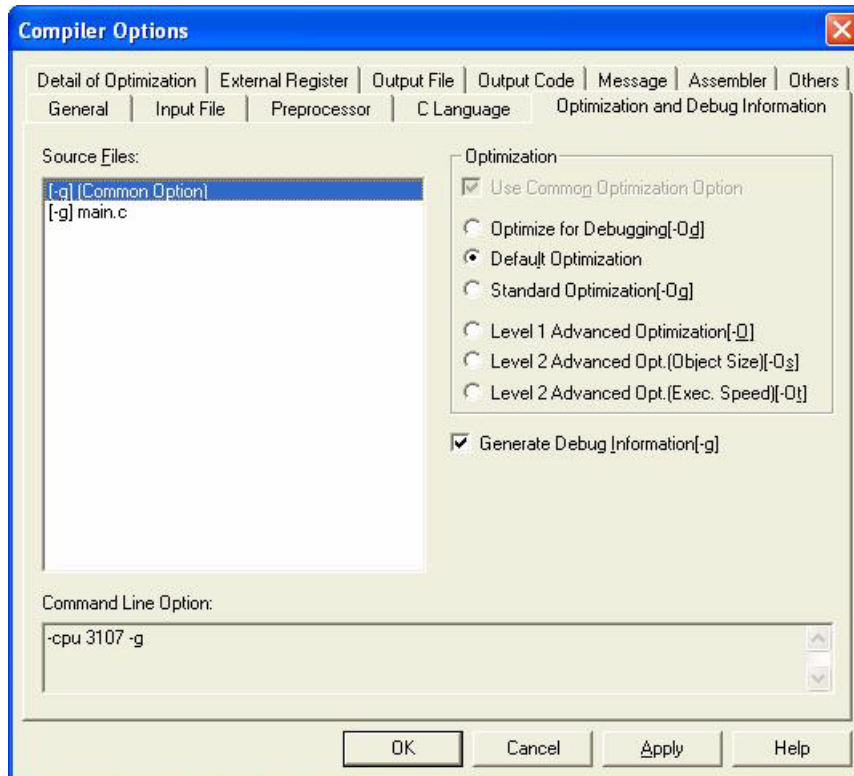

(1) Source Files

This is a list of source files registered for the current project.

When a source file is selected from this list, the optimization options and debug information setting for that specific C language source file are displayed. If you select [Common Option] from this list, the settings that apply to all options are displayed. At that point, the "Use Common Optimization Option" check box becomes invalid.

In the optimization options that are displayed when a source file is selected from this list, the "Use Common Optimization Option" check box is checked if the specified settings are the same as the default settings (which apply to all options). If any of the specified settings differ from the default settings, the currently specified optimization level is checked. The "Generate Debug Information[-g]" check box is checked if generation of debug information has been specified.

(2) Optimization**(a) Use Common Optimization Option**

This option is checked when using settings that apply to all options without using the optimization levels below this box. When this option is checked, the optimization level becomes invalid.

- Optimize for Debugging[-Od]

This option generates codes emphasizing logic debugging, without putting stress on the ROM capacity and execution speed. Its function is equivalent to the default optimization of CA850 Ver. 2.41 or earlier.

- Default Optimization

This option generates codes emphasizing logic debugging. It executes optimization within a range where logic debugging is not affected.

- Standard Optimization[-Og]

This option executes appropriate optimization. It executes optimization that allows debugging of the C language source in most cases. Because external variables are assigned to registers, both the execution speed and code size are improved from those of the default option.

- Level 1 Advanced Optimization[-O]

This option executes optimization emphasizing the ROM capacity.

- Level 2 Advanced Opt. (Object Size)[-Os]

This option executes the maximum optimization placing the utmost emphasis on the ROM capacity.

- Level 2 Advanced Opt. (Exec. Speed)[-Of]

This option executes the maximum optimization placing the utmost emphasis on the execution speed rather than on the ROM capacity.

(3) Generate Debug Information[-g]

This check box is used to generate debug information. Check it to debug a program, such as when a C language source is debugged with the debugger. It is also possible to specify whether or not debug information will be output for each source.

(4) Command Line Option

This area displays the options set in this dialog box by command line options.

This area is for reference and cannot be written to.

[Detail of Optimization]

This tab is used to set options related to optimization in phase units.

Figure 3 - 16 [Compiler Options] Dialog Box ([Detail of Optimization] Tab)

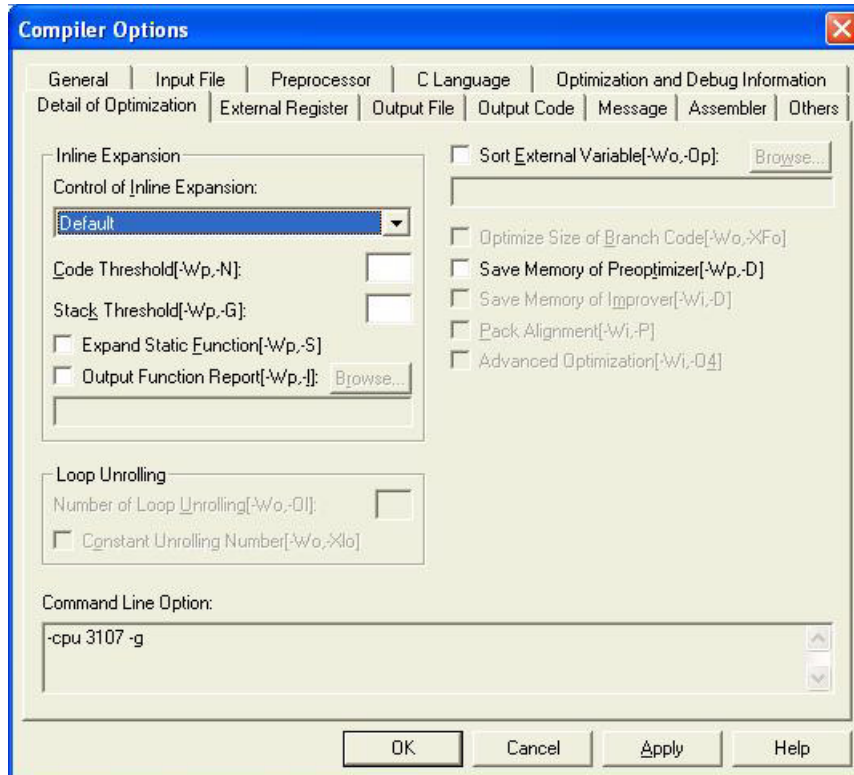

(1) Inline Expansion

(a) Control of Inline Expansion

This controls the overall inline expansion specified by the `-inline` and `-no_inline` option of the pre-optimizer.

(b) Code Threshold[-Wp,-N]

This limits the intermediate language size of a function subject to inline expansion to the specified number of bytes and does not execute inline expansion of a function exceeding this number of bytes. For a code size guideline, refer to "[Output Function Report\[-Wp,-I\]](#)" below. The default size is 128.

(c) Stack Threshold[-Wp,-G]

This limits the stack size in the intermediate language of a function subject to inline expansion to the specified number of bytes and does not execute inline expansion of a function exceeding this number of bytes. For a stack size guideline, refer to "[Output Function Report\[-Wp,-I\]](#)" below. The default size is 32.

(d) Expand Static Function[-Wp,-S]

This performs inline expansion of static functions that are referenced only once.

(e) Output Function Report[-Wp,-l]

This displays information on functions. The displayed information serves as a guideline for specifying the upper limits of "Code Threshold[-Wp,-N]" and "Stack Threshold[-Wp,-G]".

When nothing is specified to the edit box, output is to standard output.

When specifying a file name to the edit box, output is to the specified file.

Figure 3 - 17 Output Example (Function Name *func*)

function name	code	stack
_func	7	8

Note that the stack size output by this option is the size in the intermediate language that the pre-optimizer outputs. It therefore differs from the stack size the function actually uses.

(2) Loop Unrolling

(a) Number of Loop Unrolling[-Wo,-Ol]

This option unrolls a for, while, or other loop num times. It can be specified only when "Level 2 Advanced option (Exec. Speed)". Execution of a loop to be executed N times (N is a constant) is transformed into execution of a loop containing code unrolled num times. A loop may not be unrolled or the number of unrolling may be small if the size of the unrolled code is great or the number of times to execute the loop is small. Moreover, a loop that has a complicated structure, such as one containing an interior loop, may not be unrolled.

If 0 or 1 is specified in num, unrolling is suppressed. Moreover, if num is not specified, 4 is taken to have been specified. Specify num using a decimal number.

This is useful when "Level 2 Advanced option (Exec. Speed)" is specified and loop unrolling is not to be performed.

(b) Constant Unrolling Number[-Wo,-Xlo]

Use this check box to specify whether or not loop unrolling specified by the global optimization option -Xlo is performed in the same way as for previous versions (CA850 Ver. 2.02 or earlier).

This option can be specified only when "Level 2 Advanced option (Exec. Speed)" has been specified.

When this check box is checked, the result is the same as when the -Wo,-Xlo options have been specified.

(3) Sort External Variable[-Wo,-Op]

This check box is used to specify whether the external variables specified by the -Op option of the wide-range optimization block are sorted. When this box is checked, the external variables specified by the option are sorted. If nothing is specified in the edit box below this check box, the variables are sorted in a file. If a file name is specified in the edit box, an external variable file is used for sorting. All specified files are compiled and linked after all sources have been compiled. In the edit box, a file name having the same base name as a source file (file name excluding the extension) or a file name not having extension .ic must not be specified.

The -Wo,-Op option is not displayed as a command line option.

(4) Optimize Size of Branch Code[-Wo,XFo]

This check box is used to specify whether the branch instruction specified by the -XFo option of the wide-range optimization block is output, giving a priority to the code size. This check box can be used only when -Og, -O, -Os, or -Ot is specified.

(5) Save Memory of Preoptimizer[-Wp,-D]

This check box is used to decrease the memory capacity used by the pre-optimizer during compiling.

Specify this option if the memory of the machine runs short and compiling is not correctly completed. When this option is specified, the compiling speed drops.

(6) Save Memory of Improver[-Wi,-D]

This option is used to decrease the memory capacity used by the machine-dependent optimization block during compiling. Specify this option if the memory of the machine runs short and compiling is not correctly completed.

(7) Pack Alignment[-Wi,-P]

This option suppresses optimization that aligns branch destination labels. As a result, the size of the execution code can be decreased. This option is valid when Level 1 Advanced Optimization or the Level 2 Advanced Optimization (Execution Speed) -Ot option is specified. When Level 2 Advanced Optimization (Object Size) is specified, this option function is included and this option is dimmed and cannot be selected.

(8) Advanced Optimization[-Wi,-O4]

This option strictly analyzes the data flow and executes the most advanced optimization. Specify this option, in addition to the optimization option -O, -Os, or -Ot, to execute more advanced optimization.

- Optimization of registers extending over a branch instruction
- Optimization of absolute value operations
- Optimization of a cmp instruction extending over a branch instruction
- Optimization of a return instruction extending over a branch instruction

Depending on the source, the result of optimization specified by this option may be the same as that of optimization specified by the -Os or -Ot option. The compiling time when this option is specified is longer than that when -Os or -Ot is specified.

(9) Command Line Option

This area displays the options set in this dialog box by command line options.

This area is for reference and cannot be written to.

[Remark]

(a) Sort external variables

External variables can be rearranged, starting from the largest alignment size, by using the `-Wo,-Op` option. However, the variables allocated to the `const/sconst` section are not rearranged. A file name can be specified with this option, as `-Wo,-Op=file`.

If a file name is specified, the operation is as follows.

- (i) The specified intermediate file *file* is read and a list of external variables is created. If the specified file does not exist, a vacant list is created and the next processing is started.
- (ii) If the definition or temporary definition of an external variable exists in the source file, processing moves to the list created in (i). At this time, a temporary definition is changed to a definition. This means that a definition (temporary definition) in a source file is replaced by a declaration. If a variable definition of the same name already exists on the list, it is replaced by a definition of a source file. If any of the section, size, alignment, or default values is changed during replacement, a warning message is output.
- (iii) The list of external variables is output to the intermediate language file *file*. All the files compiled last and a file resulting from compiling file are linked. If the above file name is specified, the following points must be noted.
 - If all specific variables are temporarily defined in the file compiled by specifying an option and if a definition exists in a file for which no option is specified, the files can be correctly linked if an option is not specified. If an option is specified, however, a link error occurs because of duplicated definitions.
 - If variables are defined in duplicate in a file compiled by specifying an option, a link error does not occur but the definition of a file compiled later is valid.
 - To delete a variable in the intermediate language file, delete the intermediate language file itself and rebuild.

[External Register]

This tab is used to make settings related to the external variable registers.

Figure 3 - 18 [Compiler Options] Dialog Box ([External Register] Tab)

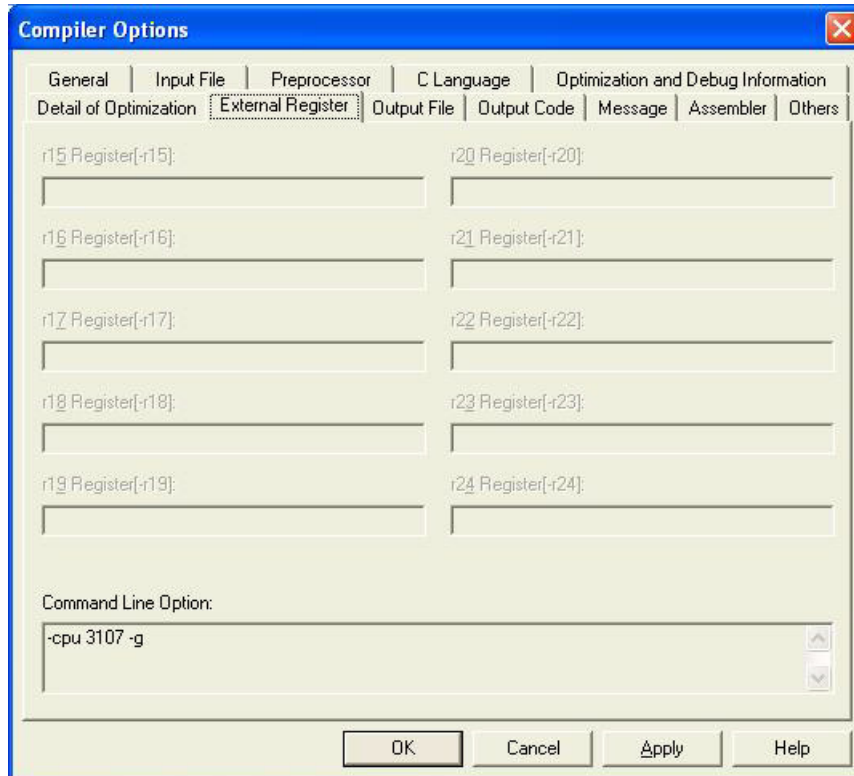

(1) *num* Register[-*num*]

These text boxes are used to specify an external variable to be allocated to the register specified by the *num* option. *num* may be 15 to 24. Therefore, there are 10 text boxes. If an external variable is specified, the effect is the same as specifying the *-num* option.

(2) Command Line Option

This area displays the options set in this dialog box by command line options.

This area is for reference and cannot be written to.

[Remark]

(a) External variable register

By using the `-rnum` option, an external variable can be allocated to a register. Specify a register other than the mask register that is vacated by specifying the `-reg` option. Specify an external variable using a symbol name, excluding `"_"`.

The following external variables must not be specified.

- volatile variable
- Variable using address operator `"&"`
- Structure
- Array
- Internally coupled variable (static)
- Peripheral I/O register

The definition (temporary definition) and declaration of the specified external variable are deleted.

To use the default value of an external variable (if initialization is not executed at the beginning of program execution), assign a default value to a register using the startup file.

Example

```
int i = 1;
```

If `"-reg26 -r19=i"` is specified in a source file defined above, a default value is assigned to the register as follows.

```
mov 1, r19      -- set i
```

Caution Optimization debugging cannot be executed (Register window is used) because the debug information of the specified external variable is also deleted.

[Output File]

This tab is used to set options related to the output file.

Figure 3 - 19 [Compiler Options] Dialog Box ([Output File] Tab)

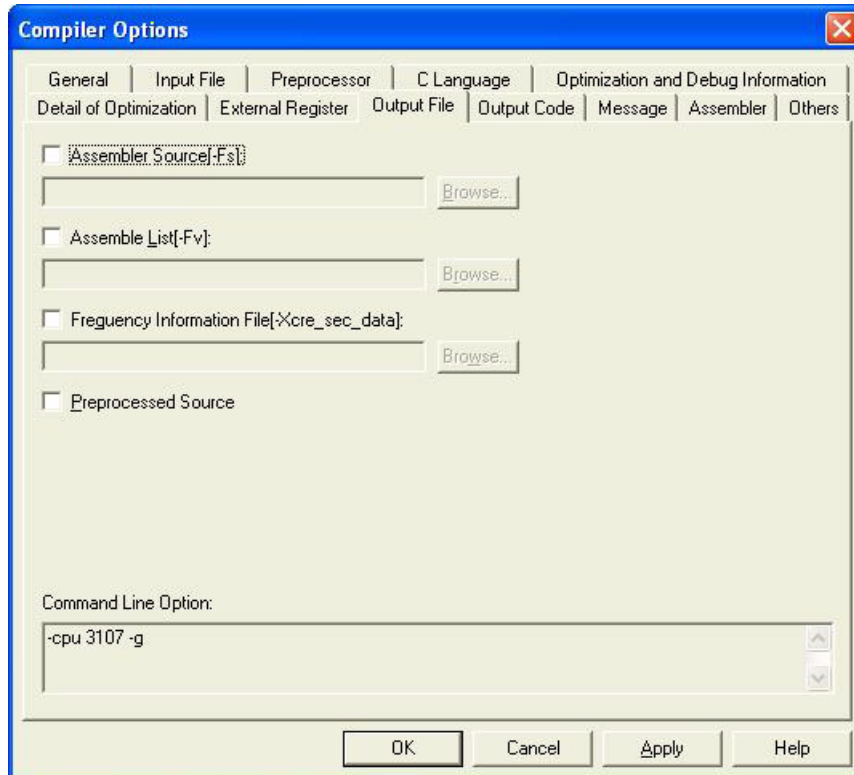

(1) Assembler Source[-Fs]

This check box specifies whether the assembly language source resulting from compiling a C language source is to be output. When it is checked, a folder name or file name can be specified in the edit box below this button. If a folder name is specified in this edit box as "Setting of global options" and if the specified folder does not exist, a message asking you if a folder is to be created is displayed. If nothing is specified in the edit box, an assembly language source is output to the project folder with the extension of the C language source file name changed to .s. To specify another output destination, specify a folder name in the edit box.

If a file name is specified for "Setting of global options", an assembly language source for the source compiled last is output because the same file name is overwritten. A file name can be specified when a file name is specified for "Individual Source Options Setting".

(2) Assemble List[-Fv]

This check box specifies whether the assemble list resulting from compiling a C language source is to be output. When it is checked, a folder name or file name can be specified in the edit box below this button. If a folder name is specified in this edit box as "Setting of a global options" and if the specified folder does not exist, a message asking you if a folder is to be created is displayed. If nothing is specified in the edit box, an assemble list is output to the project folder with the extension of the C language source file name changed to .v. To specify another output destination, specify a folder name in the edit box.

If a file name is specified for "Setting of global options", an assembler list for the source compiled last is output because the same file name is overwritten. A file name can be specified when a file name is specified for "Individual Source Options Setting".

(3) Frequency Information File[-Xcre_sec_data]

This check box specifies whether an information file of how often the variables are used by the section file generator is to be output. When this box is checked, a folder name or a file name can be specified in the edit box below this button.

If a folder name is specified in this edit box as "Setting of a global option" and if the specified folder does not exist, a message asking you if a folder is to be created is displayed. If nothing is specified in the edit box, a frequency information file is output to the project folder with the extension of the C language source file name changed to .sec. To specify another output destination, specify a folder name in the edit box.

If a file name is specified for "Setting of global options", an assembly language source for the source compiled last is output because the same file name is overwritten. To specify a frequency information file name for multiple C language source files, therefore, specify a file name using "Individual Source Options Setting". Note that this option outputs a frequency information file of variables in a C language source file, but does not output a frequency information file of an assembly language source file.

(4) Preprocessed Source

This check box is used to execute only preprocessing on a C language source program and to output the result to a file whose file is the name of the C language source file with extension .c replaced by .i. The line number and file name of the source program are not output.

(5) Command Line Option

This area displays the options set in this dialog box by command line options.

This area is for reference and cannot be written to.

[Output Code]

This tab is used to set options related to the output code.

Figure 3 - 20 [Compiler Options] Dialog Box ([Output Code] Tab)

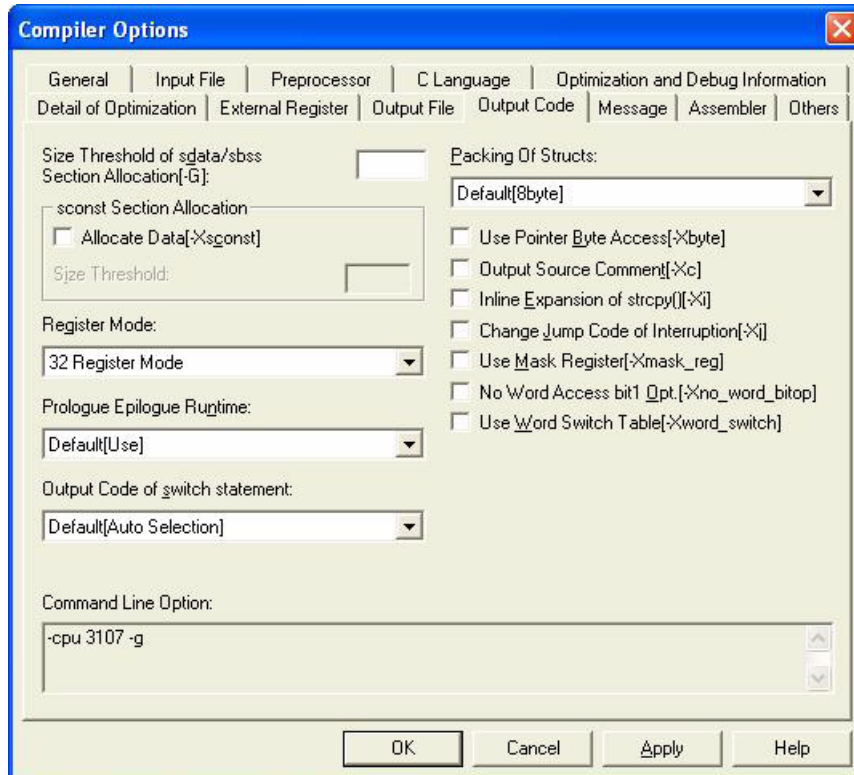

(1) Size Threshold of sdata/sbss Section Allocation[-G]

Use this area to specify the upper limit of data allocated to the .sdata/sbss section. Data of the specified size (bytes) or less is allocated to the .sdata or .sbss section. However, data for which the .sdata/.sbss section is specified by the #pragma section directive or a section file is allocated to the .sdata/.sbss section regardless of its size.

An integer of decimal values 0 to 32767 can be specified. The yardstick for the value to be specified in this area is output for reference when "Output GP Information[-A]" on the [Option] tab that sets linker options is specified.

Note that this option cannot be specified when an individual source is specified. Always specify this option as a global option.

(2) **sconst Section Allocation**

This area is used to specify allocation of const-attribute data or a character string literal, i.e., data or a character string literal with a const type modifier, to the `sconst` section.

(a) Allocate Data[-Xsconst]

When this check box is checked, data or a character string literal with the const attribute is allocated to the `sconst` section.

(b) Size Threshold

If the upper limit of a data length is input to this area, data of the specified size (bytes) or less is allocated to the `.sconst` section. However, data for which the `.sconst` section is specified by the `#pragma` section directive or a section file is allocated to the `.sconst` section regardless of its size. If nothing is input, data or a character string literal with the const attribute is allocated to the `.sconst` section. An integer of decimal values in the range of 0 to 32767 can be specified.

For details of the `.sconst` section and `.const` section, refer to CA850 for C Language User's Manual.

Caution If a section is not specified by the `#pragma` section directive or a section file, and if "Allocate Data[-Xsconst]" of "sconst Section Allocation" is not checked (default assumption), all data and character string literals for which the const type modifier is specified are allocated to the `.const` section.

(3) **Register Mode**

This area is used to specify a register mode. The following register modes can be specified. The default register mode is the 32-register mode.

- 22-register mode
- 26-register mode
- 32-register mode

The setting of the register mode is also recognized by the linker. Therefore, a library in the appropriate register mode is referenced when a library is linked.

For details of the register mode, refer to CA850 for C Language User's Manual.

(4) **Prologue Epilogue Runtime**

This specifies whether or not a runtime library call will be used for prologue/epilogue processing of functions. If "Use" is specified, the prologue/epilogue processing of functions uses run-time library calls. If "Default" is selected and if "Level 2 Advanced option (Exec. Speed)" is specified as the optimization type by an option of the [\[Optimization and Debug Information\]](#) tab, "No use" is assumed. If another type is specified, "Use" is assumed. This setting can be made for each source file. If "Default" has been specified, the same setting is used globally.

For details of prologue/epilogue processing of functions, refer to CA850 for C Language User's Manual.

(5) Output Code of switch statement

This edit area is used to specify the method of outputting the code of a switch statement.

- Default

The compiler automatically judges the format it considers the most appropriate.

- if-else

The code of the switch statement is output in the same format as an if-else statement following the arrangement of a case statement. Select this option when case statements are written in the order of frequency or when the number of labels is few.

Because the case statements are sequentially compared starting from the top, the execution speed can be improved if case statements that often match are described first because unnecessary comparison does not have to be executed.

- Binary Search

Outputs the code of the switch statement in the binary search format. If this option is selected when many labels are used, any case statement can be found at almost the same speed.

- Table Branch

Outputs the code of the switch statement in the table jump mode. A table indexed based on the value of a case statement is referenced, a case label is selected by the value of the switch statement, and processing is performed. Any case statement can be found at almost the same speed. However, unnecessary areas may be created if the case values are not contiguous.

(6) Packing Of Structs

This area is used to set structure packing specified by the `-Xpack=num` option. By using this option, specified alignment can be used, without structure members aligned in accordance with the types of the members. The data size can be decreased but the code size increases.

The value that can be specified is "1 byte", "2 bytes", "4 bytes", or "8 bytes". The default value is "8 bytes"^{Note}.

If this option is specified when structure packing is specified by the `#pragma` directive in a C language source file, the value specified by the option is applied to all structures until the first `#pragma` directive emerges. After that, the value of the `#pragma` directive is applied. Even after emergence of the `#pragma` directive, however, the value specified by the option is applied if the default assumption is specified. This option must not be specified together with the `-Xi` option. When using this option, the following points should be noted.

- If this option is specified when structure packing is specified by the `#pragma` directive in a C language source file, the value specified by the option is applied to all structures until the first `#pragma pack` directive emerges. After that, the value of the `#pragma` directive is applied. Even after emergence of the `#pragma` directive, however, the value specified by the option is applied if the default assumption is specified.

In addition, the following restrictions apply to this option. The same also applies to `#pragma pack`.

- The address of a structure member cannot be obtained correctly.
- When a bit field is accessed, a data area is also accessed because the type of the member is read.

If the width of the bit field is less than the type of the member, outside of the object is accessed because the type of the member is read. This poses no problem in execution. If an I/O is mapped, however, an illegal access may occur. For details of structure packing, refer to CA850 for C Language User's Manual.

Note The operation of this version is the same regardless of whether 4 bytes or 8 bytes are specified.

(7) Use Pointer Byte Access[-Xbyte]

This check box is used to access the indirect address of a structure in byte units. Use this box if a restriction is applied to the structure packing function.

(8) Output Source Comment[-Xc]

This option outputs a C language source program to the assembly language source file to be output as comments. However, the comments that are output are only for reference and may not strictly correspond to the codes. For example, the output position of the global variables, local variables, and function declaration may be shifted. In addition, due to optimization, the codes may be deleted and only comments may remain.

(9) Inline Expansion of strcpy[-Xi]

This check box is used to convert calling the function strcpy()/strcmp() into block transfer, setting the alignment condition of arrays (including character strings) and structures to 4 bytes. The execution speed of objects will increase but the code size will also increase.

This option executes conversion only if the second argument of strcpy()/strcmp() is a character string. The first argument must be aligned to 4 bytes by the program (the ca850 aligns the second argument because it is a character string). This option must not be specified together with the -Xpack option.

(10) Change Jump Code of Interruption[-Xj]

This check box is used to execute the jmp instruction only for a normal interrupt defined in C language.

If the body of a function is in a range to which the jr instruction cannot branch and if the ld850 outputs an error, recompile by using this option. If this option is omitted, use the jr instruction. This option must not be specified when a function on the flash side is called from the boot side by using the flash/external ROM relink function. For details, refer to "5.6 Flash Memory/External ROM Relink Function".

(11) Use Mask Register[-Xmask_reg]

This option enables use of the mask register function. When this function is used, the ca850 outputs codes, assuming that an 8-bit mask value, 0xff, is set to r20 and a 16-bit mask value, 0xffff, is set to r21. Mask values must be set to the mask registers (r20 and r21) by a user program such as the startup routine. With the V850 microcontrollers, byte data and halfword data are sign-extended to a word length, depending on the value of the most significant bit, when they are loaded from memory to registers. Consequently, the mask code of the higher bits may be generated when an operation on unsigned char or unsigned short type data is performed. When the result of an operation is stored in a register variable, a mask code is generated for unsigned byte data and unsigned halfword data to clear the higher bits. In both the cases, generation of the mask code can be avoided if word data is used. If word data cannot be used and a mask code is generated, the code size can be reduced by using the mask register function. To decide whether the mask register function is to be used or not, the following points must be thoroughly considered.

- Is it a program that outputs many mask codes?
- Two register variable registers are used as mask registers: Does this have any effect?

If an object that uses a mask register and an object that does not use a mask register exist together when this option is specified, the ld850 outputs an error. In the 32-register mode, -mask_reg is passed to the ld850. As a result, the linker searches the mask register folder for the standard library, instead of the standard folder.

For details of the mask register, refer to CA850 for C Language User's Manual. Note that this option cannot be selected when an individual source is specified. It is always set as a global option.

Caution "Use Mask Register[-Xmask_reg]" must be specified for both compiler options and assembler options in an application that uses both a C language source file and an assembly language source file, and in an application that uses only an assembly language source file.

(12) No Word Access bit1 Opt.[-Xno_word_bitop]

This check box prohibits an operation that replaces the ld.w/ld.h and st.w/st.h instructions with 1-bit memory manipulation instructions (set1, clr1, tst1, and not1). If a read/write event of a variable is set for debugging, an event may not occur if the above instructions are replaced by 1-bit manipulation instructions. In this case, specify this option. The ld.w/ld.h and st.w/st.h instructions remain not replaced, making debugging easy.

(13) Use Word Switch Table[-Xword_switch]

This option creates a branch table for the case label in a switch statement using 4 bytes per label. Specify this option if compile errors occur due to long switch statements. If this option is not specified, the branch table is generated using 2 bytes.

(14) Command Line Option

This area displays the options set in this dialog box by command line options.

This area is for reference and cannot be written to.

[Message]

This tab is used to set options related to messages.

Figure 3 - 21 [Compiler Options] Dialog Box ([Message] Tab)

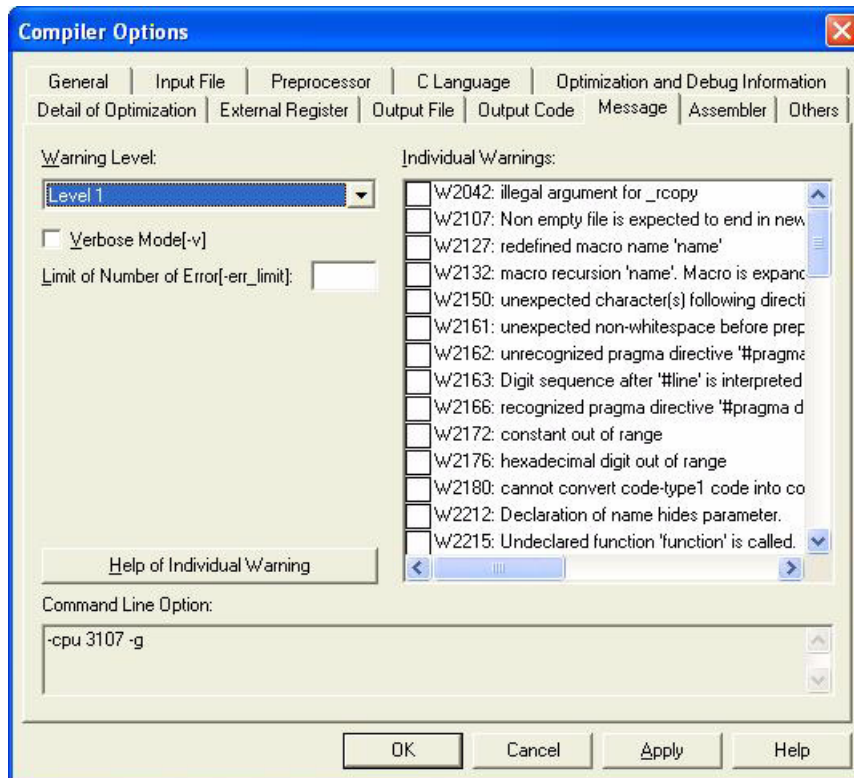

(1) Warning Level

Use this area to set the level of warning messages to be output.

No Output[-w]	Suppresses warning messages
Level 1	Outputs ordinary warning messages (default)
Level 2[-w2]	Outputs detailed warning messages

(2) Verbose Mode[-v]

This option displays the execution status of the ca850 on the Output window during build. If it is checked, the execution status of each internal phase of the compiler is displayed.

(3) Limit of Number of Error[-err_limit]

This option specifies the maximum number of error messages to be output. Specify a decimal number from 15 to 50. If this option is omitted, 15 is assumed.

(4) Individual Warnings

This list view controls display of individual warning messages. If the icon on the left of each warning message is "ON", the warning message is displayed (-won); if it is "OFF", the message is not displayed (-woff). The icon changes from "ON" – "OFF" – " " when it is double-clicked or the space key is pressed. This option cannot be set by setting a source option (it is always specified as a global option).

The following options are converted to the options of these messages when the project is read.

-wbitfield_align	W2306
-wbitfield_type	W2302
-wcallnodecl	W2215
-Xd	W2231
-wnopic	W2231
-wpragma	W2162
-wsharp	W2161

The messages that can be specified are listed below.

Table 3 - 7 Message Numbers of Messages That Can Be Specified

W2042, W2017, W2127, W2132, W2150, W2161, W2162, W2163, W2166, W2172, W2176, W2180, W2212, W2215, W2216, W2222, W2231, W2244, W2254, W2267, W2287, W2289, W2291, W2293, W2302, W2306, W2373, W2380, W2416, W2520, W2521, W2525, W2527, W2554, W2555, W2606, W2607, W2621, W2634, W2635, W2637, W2643, W2656, W2671, W2683, W2684, W2690, W2691, W2699, W2700, W2703, W2704, W2710, W2711, W2730, W2731, W2740, W2741, W2742, W2743, W2744, W2748, W2761, W2782

The [Help of Individual Warning] button can be used to display the online help of warning messages.

(5) Command Line Option

This area displays the options set in this dialog box by command line options.

This area is for reference and cannot be written to.

[Assembler]

This tab box is used to set assembler options that are used when a C language source file is assembled.

Figure 3 - 22 [Compiler Options] Dialog Box ([Assembler] Tab)

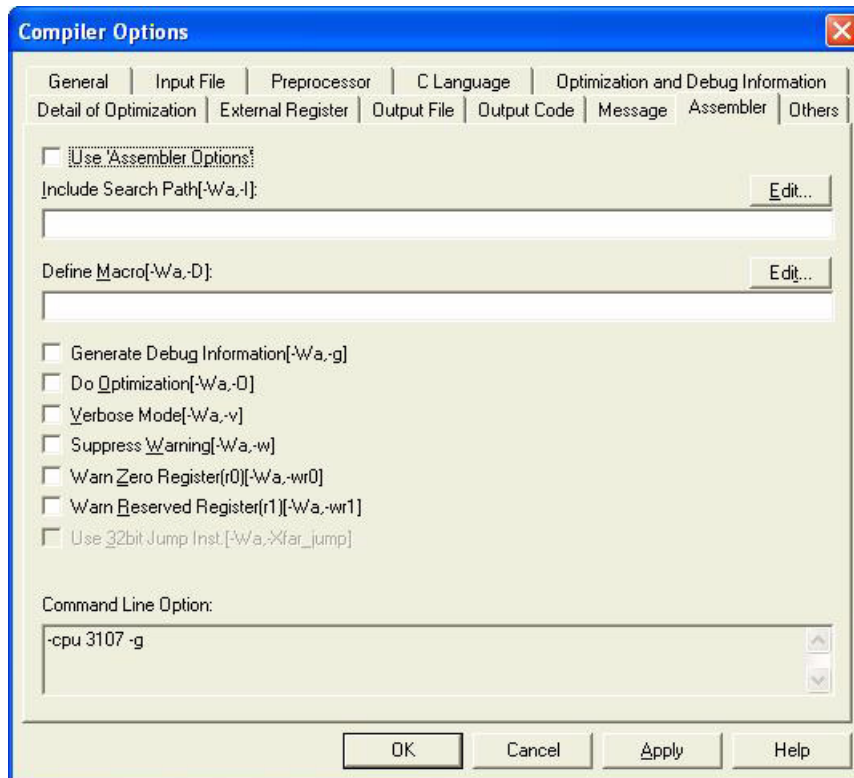

(1) Use of 'Assembler Options'

This check box specifies whether the options of [Assembler Options] dialog box, instead of the assembler options on this page, are used when assembling a C language source file. When it is checked, the options of [Assembler Options] dialog box are used.

(2) Include Search Path[-Wa,-I]

This edit box is used to specify the path of an include file. To specify two or more paths, delimit each with ";" (semicolon). This option cannot be set for an individual source (it is always set as a global option).

Note that, in addition to the path set by this option, an option set for the system may be set as a command line option. By selecting the [Edit...] button, the [Edit Option] dialog box can be displayed and the path can be edited in this dialog box.

(3) Define Macro[-Wa,-D]

This edit box is used to set a defined macro. To specify two or more macros, delimit each with ";" (semicolon). By selecting the [Edit...] button, the [Edit Option] dialog box can be displayed and the macro can be edited in this dialog box.

(4) Generate Debug Information[-Wa,-g]

This check box specifies whether debug information is to be generated. If it is checked, the effect is the same as specifying the -Wa,-g option.

(5) Do Optimization[-Wa,-O]

This check box specifies whether optimization is to be executed. If it is checked, the effect is the same as specifying the -Wa,-O option.

(6) Verbose Mode[-Wa,-v]

This check box sets whether the execution status is displayed. If it is checked, the effect is the same as specifying the -Wa,-v option.

(7) Suppress Warning[-Wa,-w]

This check box specifies whether warning messages are displayed or not. If it is checked, the effect is the same as specifying the -Wa,-w option.

(8) Warn Zero Register(r0)[-Wa,-wr0]

This check box specifies whether a warning message is displayed or not when register r0 is used as a destination register. When it is checked, the effect is the same as specifying the -Wa,-wr0+ option. When this check box is dimmed, the effect is the same as specifying the -Wa,-wr0- option.

(9) Warn Reserved Register(r1)[-Wa,-wr1]

This check box specifies whether a warning message is displayed or not when register r1 is used. When it is checked, the effect is the same as specifying the -Wa,-wr1+ option. When this check box is dimmed, the effect is the same as specifying the -Wa,-wr1- option.

(10) Command Line Option

This area displays the options set in this dialog box by command line options.

This area is for reference and cannot be written to.

[Others]

This tab is used to set other options.

Figure 3 - 23 [Compiler Options] Dialog Box ([Others] Tab)

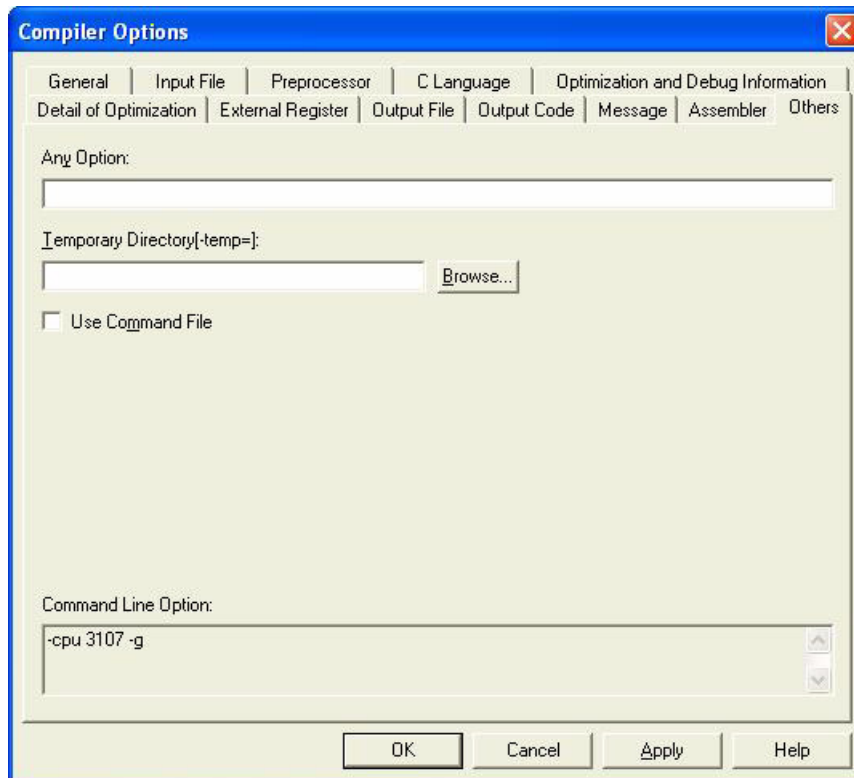

(1) Any Option

This edit box is used to specify options that cannot be set by setting in "Compiler Options" described above. Describe an option in this edit box in the same manner as on the command line.

At present, only this option can be specified as "Any Option".

- -Xv850patch

Other options can be specified but are not supported at present.

(2) Temporary Directory[-temp=]

This edit area is used to specify a work folder where a temporary file to be used internally is to be generated. If this option is omitted, the temporary file is generated as the environmental variable TEMP or in the root folder of current drive. An error that may occur because the capacity of the hard disk runs short and a temporary file cannot be generated can be avoided by using this option. If the specified folder does not exist, a message asking you if a folder is to be created is displayed.

(3) Use Command File

In the Windows environment, the length of character strings used to specify options for the ca850 is restricted. If this check box is selected, the option character string is output to a command file, which enables the operation to be completed without observing the restriction on the character string length. Check this check box if many options are set and not all of them can be recognized. Under the default setting, the check box is not checked.

For the details of command file, refer to "[3.7.2 Command file](#)".

(4) Command Line Option

This area displays the options set in this dialog box by command line options.

This area is for reference and cannot be written to.

[Button]**(a) [Delete Source Option] button**

This button can be selected when option settings for individual source files have been made, and is not displayed (is dimmed) and cannot be selected when options for the overall project have been specified.

When selected, this button deletes any option specified for a particular source file and applies only global options.

[Difference]

This tab is used to display the differences between the options for the overall project and individual source options.

Figure 3 - 24 [Compiler Options] Dialog Box ([Difference] Tab)

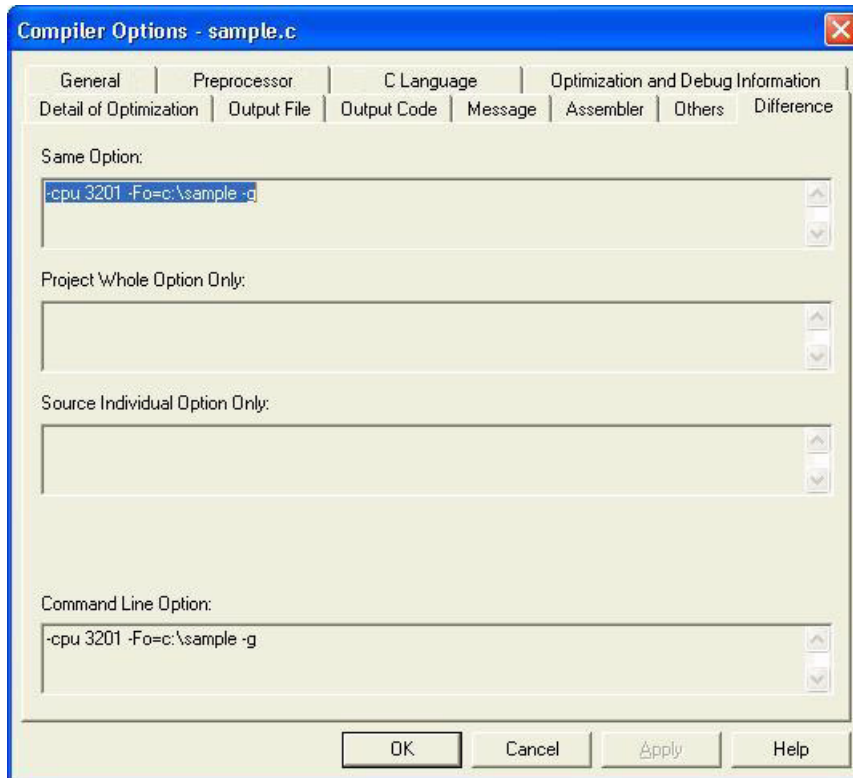

(1) Same Option

Options set as options for the overall project and options for individual sources are displayed in the command line format. This area is for reference and cannot be written to.

(2) Project Whole Option Only

Options specified as options for the overall project and not as options for individual sources are displayed in the command line format. This area is for reference and cannot be written to.

(3) Source Individual Option Only

Options specified as options for individual sources and not as options for the overall project are displayed in the command line format. This area is for reference and cannot be written to.

(4) Command Line Option

This area displays the options set in this dialog box by command line options.

This area is for reference and cannot be written to.

[Button]

(a) [Delete Source Option] button

This button can be selected when option settings for individual source files have been made, and is not displayed (is dimmed) and cannot be selected when options for the overall project have been specified.

When selected, this button deletes any option specified for a particular source file and applies only global options.

3.6.3 [Edit Option] dialog box

On the [Edit Option] dialog box, items can be selected from a list and edited.

Figure 3 - 25 [Edit Option] Dialog Box

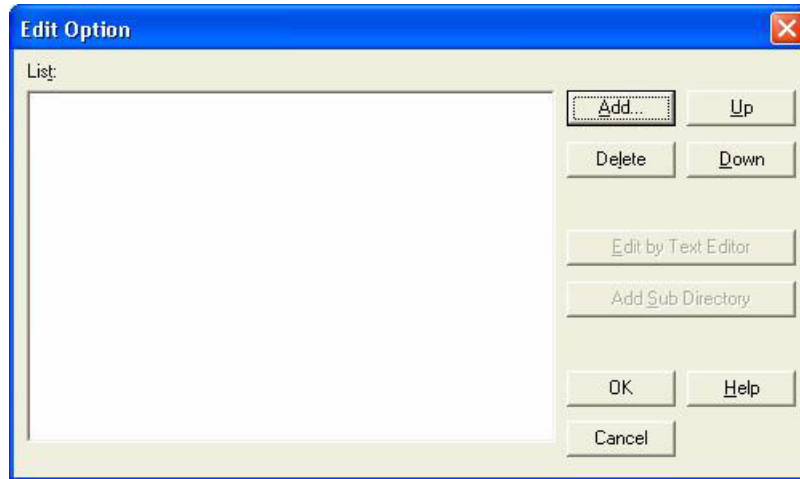

(1) [Add...] button

This button adds items to the list. In the case of an item for which a file or folder is specified, a dialog box for referencing files or folders is opened. In all other cases, a dialog box that is used to add options whose contents are to be input is opened.

Figure 3 - 26 [Add Option] Dialog Box

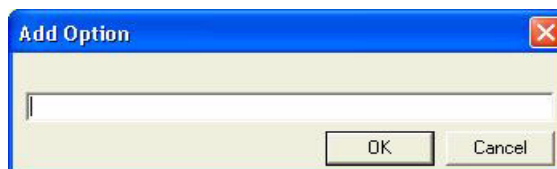

(2) [Delete] button

This button deletes the selected items on the list.

(3) [Up] button

This button moves up the selected item on the list.

(4) [Down] button

This button moves down the selected item on the list.

(5) [Edit by Text Editor] button

In the following cases, a subfolder can be added to the selected item on the list.

- "Section File[-Xsec_file]" on [Input File] tab for setting [Compiler Options] dialog box
- "Far Jump File[-Xfar_jump]" on [Input File] tab for setting [Compiler Options] dialog box

(6) [Add Sub Directory] button

In the following cases, a subfolder can be added to the selected item on the list.

- "Include Search Path[-I]" on [Preprocessor] tab for setting [Compiler Options] dialog box
- "Include Search Path[-Wa,-I]" on [Assembler] tab for setting [Compiler Options] dialog box
- "Include Search Path[-I]" on [Option] tab for setting [Assembler Options] dialog box
- "Library Search Path[-L]" on [Library] tab for setting [Linker Options] dialog box

3.7 Cautions

3.7.1 Specifying multiple options

Some options become invalid if they are specified at the same time as certain other options. Of the following options, those on the right of the ">" symbol become invalid if they are specified with the options shown on the left of the ">" symbol.

-E > -P

-U > -D

-E / P > -G / L / O / R / S / Wc / a / c / I / m / o

Since execution is terminated during preprocessing, the options related to the modules following the front end are invalid.

-S > -L / R / W[a|l] / a / c / I

Since execution is terminated at the code generation module or the machine-dependent optimization module, the options related to the modules following the as850 are invalid.

-V / -help

Any option that is specified after this is invalid. Moreover, once this option is specified, all the other options become invalid.

-c > -L / R / W / I / I

Since execution is terminated at the as850, the options related to the modules following the ld850 are invalid.

-m > -G / L / O / R / S / Wc / a / c / I

Since execution is terminated at the front end, the options related to the modules following the pre-optimizer are invalid.

-Og / -O / -Os / -Ot > -a

If -Og, -O, -Os, or -Ot has been specified, an incorrect display may result.

-Od / -Ob / -O / -Og / -Os / -Ot

Any option that is specified after this is valid.

-w / w[1|2]

Any option specified before this is invalid.

3.7.2 Command file

Instead of specifying options and file names for commands as command-line arguments, they can be specified in a command file. The ca850 treats the contents of a command file as if they were command-line arguments. In the command file, the arguments to be specified can be coded over several lines. However, options and file names must not be coded over more than one line. Command files cannot be nested.

In the command file, the following characters are treated as special characters.

" (double quotation mark)	The character string until the next " (double quotation mark) is treated as a contiguous character string.
# (sharp)	If specified at the beginning of a line, characters on that line until the end of the line are treated as a comment.
^ (circumflex)	The character immediately following this is not treated as a special character.

The special characters themselves are not included in the command line of the ca850 for which a command file is specified, but deleted.

Remark With the as850, ar850, hx850, dump850, dis850, and rom850, only " (double quotation mark) can be used.

Example of command file

```
-Dtest      ... Describes #define test
-o object   ... Specifies an object file name
a.c        ... Specifies the file to be compiled
```

Example of command file specification

```
> type cfile
    -cpu 3201 -c -Os file.c ... Contents of command file
> ca850 @cfile                ... Same operation as ca850 -cpu 3201 -c -Os file.c
```

3.7.3 Efficient use of optimization

The main types of optimization that can be specified by the -O option are described below along with instructions on the efficient use of optimization.

Figure 3 - 27 Optimization Processing and Parameters

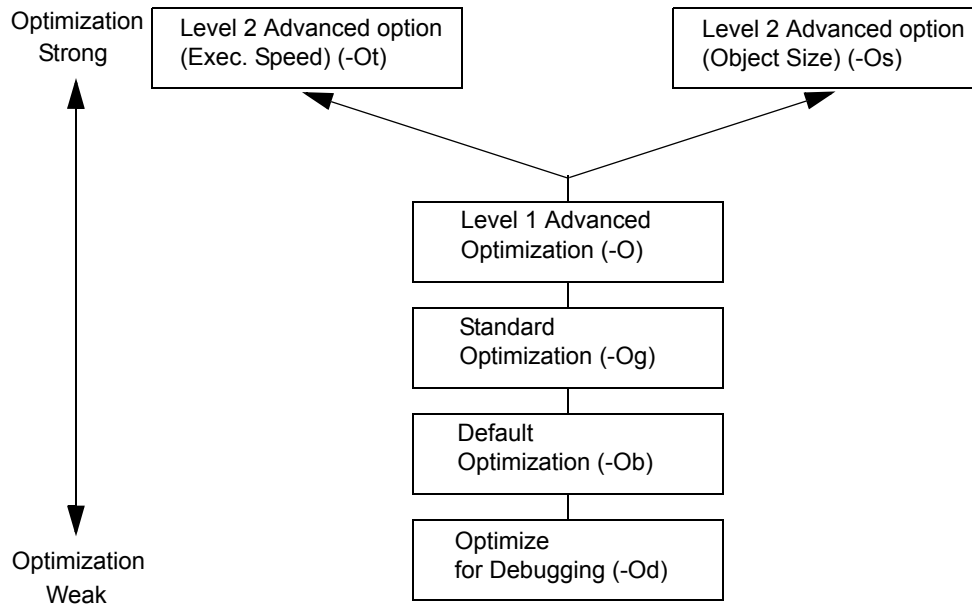

Table 3 - 8 Optimization Processing and Items

Option	Effect			
	Debug	Code Efficiency	Execution Speed	Compilation Time
-Od : Optimize for Debugging	Level 4	Level 1	Level 1	Level 3
-Ob : Default Optimization	Level 3	Level 2	Level 2	Level 3
-Og : Standard Optimization	Level 3	Level 3	Level 3	Level 3
-O : Level 1 Advanced Optimization	Level 2	Level 4	Level 4	Level 2
-Os : Level 2 Advanced option (Object Size)	Level 1	Level 5	Level 4	Level 2
-Ot : Level 2 Advanced option (Exec. Speed)	Level 1	Level 4	Level 5	Level 1

The meanings of the expressions in this table are as follows.

Debug	As the level of optimization increases, optimization that deletes C language source lines and concentrates the same processing on one location occurs, and there is a tendency that the places where breakpoints can be set decrease. In addition, the probability of assigning a variable from memory to a register improves. The level of optimization at which the tendency that many breakpoints can be set and the probability of allocating variables to registers is small is called level 4, and the level at which the tendency is the strongest is called level 1. Debugging can be executed even at level 1.
Code Efficiency	The ROM size efficiency is classified into levels 1 to 5. The option that minimizes the ROM size is -Os. This option takes a long compilation time. Use the -Og or -O option if the ROM capacity has a wide margin.
Execution Speed	The execution speed is classified into levels 1 to 5. To reduce the ROM capacity of the entire module and improve the effective speed of only critical functions further, specify the -Ot option in file units.
Compilation Time	The compilation time is classified into levels 1 to 3. Options -O, -Os, and -Ot execute powerful optimization and therefore take a longer compilation time than the other options.

(1) -Od : Optimize for Debugging

Optimization is executed within a basic block^{Note}. This is optimization using information that can be grasped in a basic block, and includes calculation of constants, deformation of expressions, recognition of common parts in a basic block, and propagation of copy in a basic block. This optimization is executed by default when compilation is executed.

For example, an operation expression of only constants is replaced by the constants of the operation result during compilation.

The effect of this optimization is weakest with the CA850. This optimization is equivalent in level to the default optimization of CA850 Ver. 2.4x.

Note The longest array of instructions whose first instruction is always executed first. A branch occurs only from the last instruction of this array.

(2) -Ob : Default Optimization

Optimization in a basic block and allocation of automatic variables to coloring registers are performed.

- Automatic variables are allocated as registers.

This optimization does not affect debugging.

This is the default optimization of the CA850. It deletes more unnecessary codes than -Od because register allocation is a high-level function.

(3) -Og : Standard Optimization

In addition to optimization in a basic block and allocation of coloring registers, the following optimization is performed by using the information that can be grasped in a function (only the representative operations are described).

- An instruction string that finds common operations and processes them all at once is output.
Step execution and breakpoints may not be set as intended by the user.
- An assignment statement whose value does not change in a loop is moved out of the loop.
Step execution and breakpoints may not be set as intended by the user.
- Redundant assignment statements are deleted.
The breakpoint of a deleted line cannot be set.
- (a) External variables are allocated to registers.
The read/write break to memory may not be correctly executed during debugging.
- (b) Optimization that rearranges instructions by the as850 to avoid register/flag hazards is performed.
This optimization does not affect debugging.

This optimization is higher in compilation speed than the advanced optimization, and its code efficiency/execution speed is intermediate in the optimization of the CA850. If the ROM capacity has a relatively wide margin, setting this option is recommended.

(4) -O : Level 1 Advanced Optimization

In addition to the optimization performed by options up to -Og, the following optimization is performed (only the representative operations are described).

- It is judged that there is no reference to an argument of a function, and the assignment code of a value to the argument is deleted.
This optimization does not affect debugging.
- Only a loop that is executed only once is unrolled to avoid the overhead of end condition judgment.
This optimization does not affect debugging.
- Label alignment and 4-byte alignment at the beginning of a function are suppressed.
This optimization does not affect debugging.
- A label not referenced is deleted.
A breakpoint cannot be set to a label that is to be deleted.
- Unnecessary instructions are deleted.
Breakpoints and step execution may not be set as intended by the user.
- Peep hole optimization (rearrangement of five or less instructions to an efficient instruction string) is performed.
Breakpoints and step execution may not be set as intended by the user.

This optimization is equivalent to the object size priority option -Os of the CA850 Ver. 2.4x. This option does not perform inline expansion of a static function that is referenced only once, which is performed with the CA850 Ver. 2.4x.

(5) -Os : Level 2 Advanced option (Object Size)

An optimization module is executed until processing of -O can no longer be optimized.

This option executes optimization giving priority to object size and is the most powerful option for an embedded system. It executes all optimization to not increase the code size of the optimization supported by the CA850 and reduces the size as much as possible.

Depending on the contents of the application, optimization can be reinforced by using the following options and functions, in addition to the above option.

- Specifying -Wi,-O4

The data flow is analyzed and optimization is reinforced. However, the compilation time tends to increase considerably.

- Using mask register

In the case of an application that often uses mask codes for operations of unsigned char and unsigned short types, the mask register function can be used to reduce the code size.

However, this function decreases the usable number of registers for register variables by two.

- Using section file

If data is allocated to the internal memory or a section that is referenced by one instruction per gp/r0, the code size can be reduced and the execution speed can be increased. If data is not allocated to a section by program, it is allocated to [tidata.byte] [tidata.word] [sidata] [sedata] [sconst] [sdata] by a section file during compilation (refer to "9.1 Section Files").

Of the optimization of the CA850 giving emphasis to the code size, this optimization minimizes the size. It is equivalent to the object size priority option -Os and optional optimization option -OI of the CA850 Ver. 2.4x. This option does not perform inline expansion of a static function that is only referenced once, which is performed by the CA850 Ver. 2.4x.

(6) -Ot : Level 2 Advanced option (Exec. Speed)

This option executes optimization, giving priority to the execution speed.

It is used to shorten the execution time, even at the expense of the size, in applications such as data processing.

In addition to the optimization performed by options up to -O, this option executes optimization of suppressing "4-byte alignment of label" and "4-byte alignment at the beginning of a function". In addition, it also executes tail recursion optimization, inline expansion, and loop expansion.

If a return statement at the end of a function calls the function itself, tail recursion optimization converts that function into a loop and reduces the stack used for function calling.

Inline expansion expands the body of a function at the part calling the function, increasing the possibility of optimization, and preventing the overhead for calling.

Loop expansion expands the loop body two or more times to increase the possibility of optimization and prevent the overhead for conditional judgment and branch.

Inline expansion and loop expansion increase the object size and improve the execution speed.

When -Ot is specified and a function including an asm statement defining a label is used, the same label is defined at the part of function definition and inline expansion. In this case, a label multiple definition error occurs.

The function specified by #pragma block_interrupt, #pragma interrupt, #pragma rtos_task, or #pragma text is not subject to inline expansion. In this case, no message is output.

If a function including an asm statement on which inline expansion is not expected to be executed is used, such as manipulation of a stack frame, an execution error may occur because an illegal function frame manipulation takes place.

Caution If the size is increased too much by the Level 2 Advanced option (Exec. Speed), adjust inline expansion and loop expansion by using the options "-Wp, -Gnum" and "-Wo, -OI".

To execute inline expansion only on a specific function, regardless of the option, use #pragma inline. This can give priority to the execution speed of only a specific function, while "size priority" is specified.

Depending on the contents of the application, optimization may be able to be reinforced by using a mask register in the same manner as when -Os is specified. In addition, optimization giving priority to the execution speed can be reinforced by using the following function.

- Expanding strcpy()

If the option -Xi, which executes "expansion of strcpy" for an application that often uses the character string copy function strcpy(), is specified, the execution time is shortened. The size increases, however.

- -Wp,-r option

An unnecessary function may be generated as a result of inline expansion that has merged source files. If the "-Wp,-r" option is specified in this case, the unnecessary functions may be deleted, and the size may be reduced.

Of the optimization of the CA850 giving emphasis to the execution speed, the execution speed of this option is the highest. This option is equivalent to the execution speed priority option -Ot + optional optimization option -OI of the CA850 Ver. 2.4x.

As explained above, the CA850 has several levels and items of optimization. To specify optimization, the following criteria must be noted.

- Giving priority to size
- Giving priority to the execution speed at the expense of size

Most optimization functions reduce the size and improve the execution speed at the same time. Whether emphasis is given to the size or execution speed is determined depending on whether some functions are used or not.

3.7.4 Effects of optimization on debugging

Note with caution that optimization can have the following kinds of effects when using the source debugger.

- (1) As a result of deformation of an expression by optimization (propagation of copy and recognition of common part expression), "variable reference" does not take place where the read/write event of a variable appears in the source program, and the event may not occur as expected by the user.
- (2) When a statement has been made common, deleted, or rearranged, step execution or breakpoints may not be set as intended by the user.
- (3) The live range of a variable (range in which the variable can be referenced in the program) and position of a variable (position on a register or memory) may be changed.
- (4) Breakpoints cannot be set for statements that have been deleted.
- (5) Transfer, splitting, or merging of statements may have rearranged the sequence of executable instructions^{Note}, so that lines between the lines which have been rearranged may be handled as a single line for which break points and step execution can no longer be set.

Note The address of an executable instruction within a line of source code may be smaller than the address of an executable instruction in a previous line or may be greater than the address of an executable instruction in a subsequent line.

- (6) If the sequence of executable instructions for if-else statements has been rearranged or if loop unrolling has caused a sequence of executable instructions to be rearranged, step execution may no longer be possible, as in (2) above.
- (7) The entire function is regarded as the valid range (scope) for all automatic variables. However, if automatic variables have been allocated to registers, they can be deleted or otherwise rendered invisible by optimization even when they are within the scope. This can occur when the variables are being used as "local variables" within the scope or have been assigned as local variables as a result of optimization.

Example

```
void f(void)
{
    int a;          /* Valid within function */

    /* address 1 */
    :
    /* The a is used only within the range from address 1 to address 2. */
    :
    /* address 2 */
}
```

In the above example, the scope of "a" is the entire function f(). However, use of "a" is limited to section between address 1 and address 2. In this case, if "a" is allocated to a register and optimization causes it to be deleted from the stack frame, "a" will become invisible outside of the section between address 1 and address 2. This phenomenon occurs in order to make more efficient use of registers by making the register where "a" has been allocated (except for the section between address 1 and address 2) available for the allocation of other variables.

- (8) At compile time, the processing of debugging information uses a large amount of memory and therefore can cause an "out of memory" condition to occur.
- (9) Step execution cannot be performed when using sections that have been merged into one line during inline expansion.
- (10) Step execution cannot be performed when using sections that have been merged into one main loop section during loop unrolling. Also, the stop point for merging of loops into one main loop section is the number of loops after expansion, not the number of loops before expansion.
- (11) If a register is allocated to an external variable, optimization debugging cannot be executed because the debug information of the specified external variable is deleted.

CHAPTER 4 ASSEMBLER

This chapter describes the outline, operation, assemble list, and output messages of the assembler (as850).

4.1 Flow of Operation

The as850 assembles an assembly language source program in a specified assembly language source file and creates a relocatable object file (refer to [Figure 4 - 1](#)).

Figure 4 - 1 Operation Flow of as850



4.2 Input/Output Files

With the as850, the following file can be specified as an input file.

- *file.s* ... assembly language source file (called the ".s file")

The file name of the relocatable object file generated by the as850 has extension .o instead of .s. Any kind of characters that can be recognized in Windows can be specified as a file name; however, "@" cannot be used for the beginning of a file name because "@" is regarded as a command option. The name of a file, folder, or folder that includes a space cannot be used. If the Kanji code of the file is EUC, a file name, folder name, or folder name in Japanese cannot be used.

If the relocatable object file created by the as850 includes an unresolved external reference, its relocation remains unresolved.

An executable object file resolving all relocations (called the "execution format") is created by linking the relocatable object file via the linker (ld850).

4.3 Operation Method

This section explains how to operate the as850.

4.3.1 Command input method

The as850 is started from the ca850 under the default settings, but it can also be started in the following format.

Enter the following from the command prompt.

```
as850 [option] ... file name [option] ...  
[ ]: Can be omitted  
...: Pattern in preceding [ ] can be repeated
```

4.3.2 Method using PM+

The [\[Assembler Options\] dialog box](#) that is used to set assembler options for assembly language source files can be displayed via either of the following methods once a project has been established under PM+.

- Set for all assembly language source files of the target project
 - (1) Select [Tool] - [Assembler Options...]
- Set for a specific assembly language source files
 - (1) Select the name of the assembly language source file to be set a option in the [Project] window on the PM+.
 - (2) Select [Individual Assembler Options...] item that is displayed by clicking the right mouse button.

4.4 Types and Features of Options

The following table lists the options of the as850.

To pass the following options from the ca850 to the as850 without modification, "-Wa" must be specified with the ca850 (refer to "[3.5.10 Option to each module](#)").

Some options listed below are not included in the PM+'s option settings dialog box. When one of these options must be specified, activate as850 from the command line

[Symbols used in option list]

[V850E2]	Option dedicated to V850E2 core
[V850E]	Option dedicated to V850Ex core
[PM+]	Option exists as specification item under the PM+.

4.4.1 File

This specifies options of preprocessing for the assembly language source file.

-a

[PM+]

This option generates an assemble list.

However, if the **-O** option (optimization option) has also been specified, the instructions are rearranged and the assemble list output may be incorrect in some parts.

+err_file=file

This option adds and saves error messages to the file *file*.

-err_file=file

This option overwrites and saves error messages to the file *file*.

-l file

[PM+]

This option assigns *file* as the name of the file where the assemble list file is inserted after it is generated by specification of the **-a** option.

This option is ignored if the **-a** option was not specified.

If the **-a** option was specified but this option was omitted, the generated assemble list is output via standard output.

4.4.2 Option

This specifies options of the as850 for the assembly language source file.

-Dname [=def]

[PM+]

This option specifies the macro name to be defined. If the =def specification is omitted, the def value is regarded as 1.

It is assumed that .set name, def is entered before the assembly language source program.

-Gnum

[PM+]

This option generates a machine language instruction on the assumption that all data of the specified size (num bytes) or smaller is allocated to sections with the "sdata" or "sbss" attribute in response to external label access. An integer in the range of decimal values 0 to 32767 can be specified as the num value.

If this option is omitted, it is assumed that num = ∞.

However, machine language is generated on the assumption that data is allocated to sections with the "sdata" or "sbss" attribute based on the .option quasi directive.

-I dir

[PM+]

This option specifies the folder where the file specified by the file input quasi directive (.include/.binclude) is searched prior to the folder where the source files are placed.

If the file was not found in the specified folder or if this option is omitted, the folder where the source file is placed, the folder where the C language source file is placed, and the current folder are searched in that order.

-m

[PM+]

This option generates an object file that includes information noting use of the mask register function. When this function is used, the as850 outputs codes on the assumption that an 8-bit mask value 0xff is set to r20 and a 16-bit mask value 0xffff is set to r21. Mask values must be set to the mask registers (r20 and r21) by a user program such as the startup routine. To decide whether the mask register function is to be used or not, the following points must be thoroughly considered.

- Is it a program that outputs many mask codes?
- Two register variable registers are used as mask registers. Does this have any effect?

-O**[PM+]**

This option executes optimization, which rearranges instructions to avoid register and flag hazards (refer to the `-g` option).

If this option is specified with the `-g` option, this option is ignored and the `-g` option is valid.

If this option is specified with the `-p` option when the target device of the V850 core is specified or when a V850 core common object is created, this option is ignored and the `-p` option is valid.

If this option is specified with the `-p` option when the target device of the V850Ex core/V850E2 core is specified or when a V850Ex core/V850E2 core common object is created, both this option and the `-p` option are valid.

-v**[PM+]**

This option displays the as850's execution status to standard error output.

-w**[PM+]**

This option does not output a warning message in the following cases.

- (1) If r1 has been specified as the source register or the destination register
- (2) If r0 has been specified as the destination register
- (3) If r20 or r21 has been specified as the destination register when using the mask register function

-wstring+**-wstring-****[PM+]**

This option specifies output or suppression of a warning message for each message, regardless of whether the `-w` option is specified. If "+" is specified, the message is output. If "-" is specified, message output is suppressed.

The following character string can be specified as *string*.

r0	If r0 is specified as the destination register
r1	If r1 is specified as the source or destination

An error occurs if neither "+" nor "-" is specified.

-Xfar_jump**[V850E2] [PM+]**

When a V850E2 core is specified as the device type in the assembler, far jump is specified for branch instructions (`jarl`, `jr`) that do not include 22/32. To change the setting in instruction units, explicitly describe `jarl22/jarl32` or `jr22/jr32`.

Also, the `jmp` instruction is not affected by this option.

4.4.3 Device

This specifies options related to the device of the as850 for the assembly language source file.

-x256M

[PM+]

This option handles the memory space as a 256 M bytes space. If this option is not specified, the memory space is handled as a 64 M bytes space and addresses are resolved. Set this option in accordance with the chipset to be used. The physical address space of the V850Ex core has 256 M bytes in many cases. When creating an application that uses a space between 64 M bytes and 256 M bytes, specify this option.

-bpc=num

[PM+]

This option sets the higher address of the programmable peripheral I/O register. In *num*, specify only the part of address from which the highest bit of the BPC register is removed.

If the target device has programmable peripheral I/O register functions (such as V850E/IA1), the value must be determined when compiling (assembling) the application to set the variable address portion (= value set in BPC register). Thus, specifying this option compiles (assembles) using the specified value.

When specifying this option, be sure to specify a value. A binary, octal, decimal, or hexadecimal number can be used for the value. If an invalid value is specified, or if a value outside the range that can be set in the BPC register is specified, a warning message is output and this option is ignored.

Example

```
-Xbpc=0x1234
```

In the above case, if the target device is the V850E/IA1, the start address of the programmable peripheral I/O register area is treated as this value shifted 14 bits to the left, or 0x48d0000.

One value is set for an entire application. If you specify "-Xbpc" or "-bpc" when setting options by file, make the values the same between files. However, this option need not be specified for files that do not use the programmable peripheral I/O register.

If this option is specified for a target device that does not have programmable peripheral I/O register functions or when assembling as a common to V850 core/V850Ex core/V850E2 core, a warning message is output and this option is ignored.

This option is for determining the address of the programmable peripheral I/O register when compiling (assembling) and does not actually cause a value to be reflected in the BPC register. For operation, it is necessary to set a value in the BPC register separately using a startup module or the like. A sample appears (commented out) in the startup module included in the package.

Example

For the V850E/IA1, specify the following descriptions in the startup module to make the variable portion of the start address of the programmable peripheral I/O register "0x1234" and set the flag 0x8000 that enables the use of this function.

```
mov 0x9234, r10 -- 0x1234 | 0x8000 = 0x9234
st.hr10, BPC
```

The assembler outputs a .bpc section in the special reserved sections when the programmable peripheral I/O register is referenced, regardless of whether this option is specified or omitted. This section is used for checking when linking. The .bpc section is a special reserved section for information and is never loaded into memory. Therefore, it need not be specified in a link directive like a normal section.

4.4.4 Other

This sets the other options of the as850 for the assembly language source file.

-cn

The "common magic number" value common to V850 core is embedded in the generated object as the magic number, which enables the object to be used as a common object within the V850 core. If this option is omitted, a magic number defined by the specified target device is embedded. For further description of magic numbers, refer to "4.7.1 Magic number".

-cnv850e

[V850E]

This option sets the "common magic number" common to the V850Ex core as the magic number of the object to be generated. This will enable the object to be used within the V850Ex core.

If this option is omitted, a magic number defined for the specified target device is set.

-cnv850e2

[V850E2]

This option sets the "common magic number" common to the V850E2 core as the magic number of the object to be generated. This will enable the object to be used within the V850Ex core.

If this option is omitted, a magic number defined for the specified target device is set.

-cpu *devicename*

This option specifies the target device. This option takes precedence over the .option cpu quasi directive. If a target device is specified by this option or the .option quasi directive and the -cn/-cnv850e/-cnv850e2 option are specified, a core common object including information peculiar to the target device can be created.

If neither the .option cpu quasi directive nor -cn/-cnv850e/-cnv850e2 option is specified, and if this option is omitted, assemble is stopped.

-F *devpath*

This option specifies the folder where the device files are stored. If this option is omitted, the standard folder is specified.

The as850 handles folders from the as850's installation folder to the folder at the ..\dev position as the standard folders for device files.

-f

This option creates an object file having information "a new format of function calling". It is useful for using the assembly language source file created with the ca850 of the previous version (Ver.1.xx).

The present version executes assemble, assuming that this option is specified by default.

-g

[PM+]

This option outputs symbol information for the source debugger. This means that, when this option is specified, debugging can be executed at assembly language source level. When the optimization (-O) option is specified simultaneously, this option is ignored if there are sections for debug information in the source file. If sections for debug information do not exist, the optimization option is ignored and this option is valid. In other words, this option takes precedence if there is no debug information.

-o *ofile*

This option specifies *ofile* as the name of the created object file.

If this option is omitted, the object file name extension *.s* is replaced by *.o*.

-p [*num*]

This option outputs code that avoids CPU faults. Specify the type of code to output (1 to 10 or 4a) in *num*. Types 1 to 4 and 4a are valid for the V850 core, and types 5 to 10 are valid only for the V850Ex core/V850E2 core. If *num* is omitted, the following types of code are output as determined from the device file.

- (1) If the target device is a V850E2 core or if "Common to V850E2 core [-cnv850e2]" is specified in "Magic Number" in the assembler options, output codes of types 5 to 10.
- (2) If the target device is a V850Ex core or if "Common to V850Ex core [-cnv850e]" is specified in "Magic Number" in the assembler options, output codes of types 5 to 10.
- (3) If the target device is a V850 core, output codes of types 1 to 3.
- (4) If "Common to V850 core [-cn]" is specified in "Magic Number" in the assembler options, output codes of types 1 to 3 and 5 to 10.

For details of the code output due to this option, refer to "[4.7.2 Options for avoiding CPU faults](#)".

-v

This option outputs the as850's version number to standard error output and then terminates processing.

-zf

This options performs assembly processing on the Flash/External ROM side when the Flash/External ROM relink function has been used for the assembly language source file.

If this option is omitted, assembly processing is performed on the Boot/internal ROM side when the Flash/External ROM relink function has been used for the assembly language source file.

There is no need to specify this option for assembly language source files that cannot use the Flash/External ROM relink function.

Warning messages are not output concerning this option.

For details of the flash memory/external ROM relink function, refer to "[5.6 Flash Memory/External ROM Relink Function](#)".

@*cfile*

This option handles *cfile* as a command file. A command file specifies an option and a file name for a command not as arguments on the command line but by describing them in a file. On Windows, the length of a character string specified as an option of a command is limited. If many options are set and some of the options cannot be recognized, create a command file and specify this option.

For details of the command file, refer to "[3.7.2 Command file](#)".

4.5 Settings Made via PM+

This section describes dialog boxes that are used to set the command options of the as850 for the target project's source file.

After setting the project via the [Project] menu, use either of the following methods to open the [\[Assembler Options\] dialog box](#).

- Set for all assembly language source files of the target project
 - (1) Select [Tool] - [Assembler Options...]
- Set for a specific assembly language source file
 - (1) Select the name of the assembly language source file to be set an option in the [Project] window on the PM+.
 - (2) Select [Individual Assembler Options...] item that is displayed by clicking the right mouse button.

When a specific setting has been performed, the general option settings become invalid for that file. For a file for which specific options have been set, the icon at the head of the file name of the source file that is displayed in the Project window changes to green.

To make specific option setup invalid and have general option setup take effect, click the [Individual Assembler Option Release] item that is displayed by clicking with the right mouse button, or click the [Delete Source Option] button that has been added to [\[Option\]](#) and [\[Difference\]](#) tabs in the [\[Assembler Options\] dialog box](#).

The option name displayed in "[]" in each option of the option settings dialog box is the option name for starting from the command prompt. On the other hand, to specify output object names, etc., there are options that can be specified only at startup from the command line.

To use the flash area relink function, the "-zf" option of the as850 is necessary for generating an object in the flash area. To set this option, use ["Create Flash Object"](#) or ["Create Flash Side Archive File"](#) check box on the [\[Flash\]](#) tab in the [\[Compiler Common Options\] dialog box](#).

4.5.1 [Assembler Options] dialog box

At the upper part of this dialog box, the following one tab is displayed.

The contents of this dialog box depend on selecting the following tab.

Table 4 - 1 [Assembler Options] Dialog Box

Tab	Description
[Option]	Setting of assembler options

The following two tabs are displayed for a individual assembly language source file setting.

Table 4 - 2 [Assembler Options] Dialog Box (Individual Source)

Tab	Description
[Option]	Setting of assembler options
[Difference]	Indication of differences between the assembler options for the overall assembly language sources and the individual source options.

Note The option shown with "[]" in this dialog box is the option that is activated from the command line.

[Option]

This tab is used to set assembler options.

Figure 4 - 2 [Assembler Options] Dialog Box ([Option] Tab)

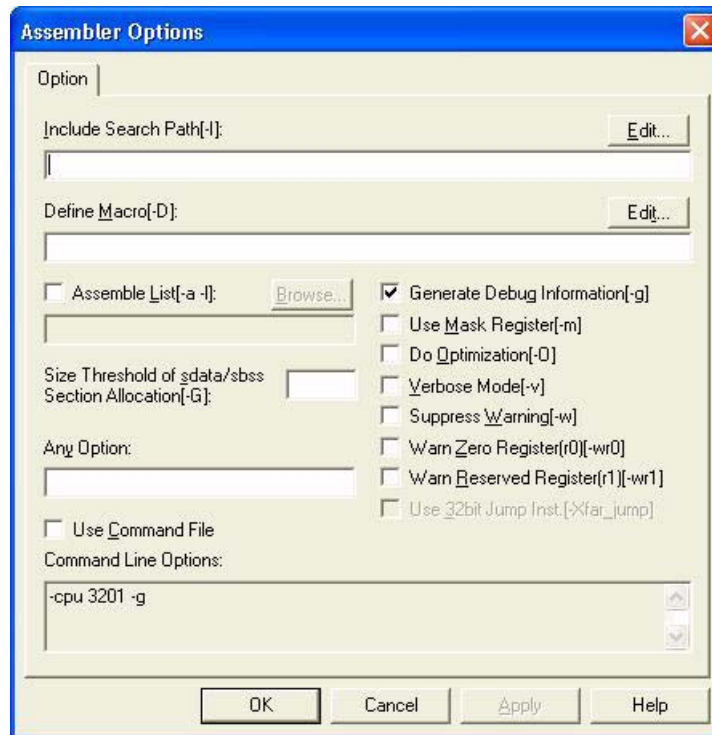

(1) Include Search Path[-I]

This option specifies the folder that is searched for the file specified by the file input quasi directive (`.bininclude/` `.include`) prior to the folder where the source file is placed. When specifying several paths, use a semicolon ";" (semicolon) to delimit the path specifications.

Selecting the [Edit...] button displays the [\[Edit Option\] dialog box](#), where path names can be edited. This option cannot be set independently for each source file, and is always used for all files.

If this option is omitted and if the specified folder is not found, the following folders are sequentially searched.

- (1) Folder where the assembly language source file is placed
- (2) Folder where the original C language source file is placed if the assembly language source file has been created from a C language source file (detected by the `.file` quasi directive)
- (3) Project folder (current folder when a command is activated if the command is activated from the command prompt)

(2) Define Macro[-D]

This option specifies a macro name to be defined in the "Macro name = define value" format. If "= define value" is omitted, the define value is regarded as 1. ".set macro name, define value" is assumed to be described before the assembly language program. When defining several macros, use a semicolon ";" to delimit the macro definitions. This edit box is used to set a defined macro.

To specify two or more macros, delimit each with ";" (semicolon). By selecting the [Edit...] button, the [\[Edit Option\] dialog box](#) can be displayed and the macro can be edited in this dialog box.

(3) Assemble List[-a -l]

This check box specifies whether the assemble list resulting from assembling a assembly language source is to be output. When it is checked, a directory name or file name can be specified in the edit box below this button. If a folder name is specified in this edit box as "Setting of a global options" and if the specified folder does not exist, a message asking you if a folder is to be created is displayed. If nothing is specified in the edit box, an assemble list is output to the project folder with the extension of the assembly language source file name changed to .v. To specify another output destination, specify a folder name in the edit box.

If a file name is specified for "Setting of global options", an assembler list for the source compiled last is output because the same file name is overwritten. A file name can be specified when a file name is specified for "Individual Source Options Setting".

(4) Size Threshold of sdata/sbss Section Allocation[-G]

Use this area to specify the upper limit of data allocated to the .sdata/sbss section. Data of the specified size (bytes) or less is allocated to the .sdata or .sbss section. However, data for which the .sdata/.sbss section is specified by the #pragma section directive or a section file is allocated to the .sdata/.sbss section regardless of its size. An integer of decimal values 0 to 32767 can be specified. The yardstick for the value to be specified in this area is output for reference when "[Output GP Information\[-A\]](#)" on the "[\[Option\]](#)" tab that sets linker options is specified. Note that this option cannot be specified when an individual source is specified. Always specify this option as a global option.

The value specified in the assembler is set in "[Size Threshold of sdata/sbss Section Allocation\[-G\]](#)" of the [\[Output Code\]](#) tab. This option cannot be set independently for each source file, and is always used for all files.

For the details of sdata/sbss section, refer to CA850 for C Language User's Manual.

(5) Any Option

This edit box is used to specify an option other than those described above in the [Assembler Options] dialog box. Describe an option in this edit box in the same manner as on the command line.

At present, only the following option can be specified as Any Option

- -p

Other options than this can be specified but are not supported at present.

(6) Generate Debug Information[-g]

This option outputs debug information. Check this box to debug a program, for example, when an assembly language source is debugged with the debugger. If the optimization option (-O) is specified at the same time and if a section for debug information is in the source file, this option is ignored. If there is no section for debug information, the optimization option (-O) is ignored, and this option is valid. In other words, this option takes precedence if there is no debug information.

(7) Use Mask Register[-m]

This option specifies use of the mask register function.

When this function is used, the ca850 outputs codes, assuming that an 8-bit mask value, 0xff, is set to r20 and a 16-bit mask value, 0xffff, is set to r21. Mask values must be set to the mask registers (r20 and r21) by a user program such as the startup routine.

To decide whether the mask register function is to be used or not, the following points must be thoroughly considered.

- Is it a program that outputs many mask codes?
- Two register variable registers are used as mask registers: Does this have any effect?

If an object that uses a mask register and an object that does not use a mask register exist together when this option is specified, the ld850 outputs an error.

(8) Do Optimization[-O]

This option executes optimization to rearrange instructions to avoid register and flag hazards. If this option is specified together with the -g option (which outputs information for the debugger), this option is ignored, and the -g option is valid.

This option is also ignored when it is specified together with the -p option (to avoid CPU bugs) when a V850 core target device is specified or when a V850 core common object is created, and the p option is valid. If this option is specified together with the -p option when a V850Ex core/V850E2 core target device is specified or when a V850Ex core/V850E2 core common object is created, both this option and the -p option are valid.

(9) Verbose Mode[-v]

This option displays the detailed execution status of the as850 on the Output window.

(10) Suppress Warning[-w]

This option specifies whether the warning message specified by the -w option is suppressed or not. If this check box is checked, the effect is the same as specifying the -w option.

(11) Warn Zero Register(r0)[-wr0]

This option specifies whether a warning message is suppressed or not when the r0 register specified by the -wr0 option is used as a destination register. If this check box is checked, the effect is the same as specifying the -wr0+ option. When it is dimmed, the effect is the same as specifying the -wr0- option.

(12) Warn Reserved Register(r1)[-wr1]

-This option specifies whether a warning message is suppressed when the r1 register specified by the -wr1 option is used. If this check box is checked, the effect is the same as specifying the -wr1+ option. When it is dimmed, the effect is the same as specifying the -wr1- option.

(13) Use 32bit Jump Inst[-Xfar_jump] [V850E2]

When a V850E2 core is specified as the device type in the assembler, far jump is specified for branch instructions (jarl, jr) that do not include 22/32. To change the setting in instruction units, explicitly describe jarl22/jarl32 or jr22/jr32.

Also, the jmp instruction is not affected by this option.

(14) Use Command File

In the Windows environment, the length of character strings used to specify options for the ca850 is restricted. If this check box is selected, the option character string is output to a command file, which enables the operation to be completed without observing the restriction on the character string length. Check this check box if many options are set and not all of them can be recognized. Under the default setting, the check box is not checked.

For the details of command file, refer to "[3.7.2 Command file](#)".

(15) Command Line Options

This area displays the options set in this dialog box by command line options.

This area is for reference and cannot be written to.

[Button]**(a) [Delete Source Option] button**

This button can be selected when option settings for individual source files have been made, and is not displayed (is dimmed) and cannot be selected when options for the overall project have been specified.

When selected, this button deletes any option specified for a particular source file and applies only global options.

[Difference]

This tab is used to display the differences between the options for the overall project and individual source options.

Figure 4 - 3 [Assembler Options] Dialog Box ([Difference] Tab)

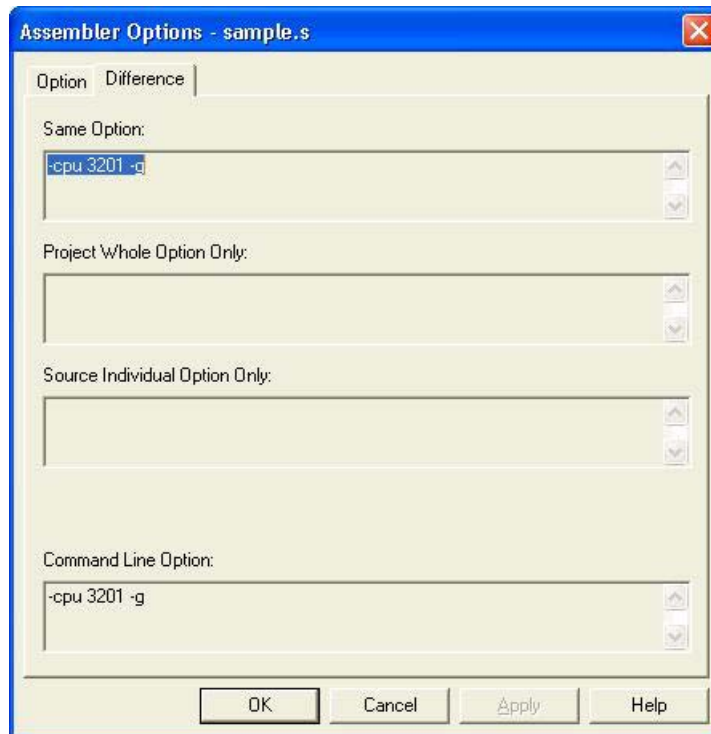

(1) Same Option

Options set as options for the overall project and options for individual sources are displayed in the command line format. This area is for reference and cannot be written to.

(2) Project Whole Option Only

Options specified as options for the overall project and not as options for individual sources are displayed in the command line format. This area is for reference and cannot be written to.

(3) Source Individual Option Only

Options specified as options for individual sources and not as options for the overall project are displayed in the command line format. This area is for reference and cannot be written to.

(4) Command Line Option

This area displays the options set in this dialog box by command line options.

This area is for reference and cannot be written to.

[Remark]

(a) [Delete Source Option] button

This button can be selected when option settings for individual source files have been made, and is not displayed (is dimmed) and cannot be selected when options for the overall project have been specified.

When selected, this button deletes any option specified for a particular source file and applies only global options.

4.6 Assemble List

This section describes the assemble list.

An assemble list is a list-formatted version of the code that is produced when the source has been compiled and assembled. It can be used to check the code resulting from compilation and assembly.

4.6.1 Output method

The assemble list can be output as follows.

(1) Command input

When the `-a` option has been specified, the assemble list is output via standard output. If the `-a` option is specified along with the `-l` option which specifies an output file name, the assemble list is output to the specified file.

When using the CA850 to compile the C language source, if the "output assemble list" has been specified along with "output source comment" (via the `-Xc` option), the C language source line that corresponds to the code appears as comments in the assemble list. However, the code line and source line may not correspond if optimization has been forced.

(2) PM+

Specify "[Assemble List\[-l\]](#)" via the [\[Assembler Options\] dialog box](#). The list is output to a file, and the file name extension is changed to ".v".

When compiling the C language source, if "[Assemble List\[-Fv\]](#)" has been specified via the [\[Compiler Options\] dialog box](#) and "[Output Source Comment\[-Xc\]](#)" has also been specified, the C language source line that corresponds to the code appears as comments in the assemble list. However, the code line and source line may not correspond if optimization has been forced.

4.6.2 Output example

An assemble list output example is shown below. In addition, [Figure 4 - 4](#) shows an example of the assemble list that is output by compiling the C language source program in the example and then assembling the output assembly language source program.

[Source]

```
void main(void)
{
    int a;
}
```

[Output assemble list example]

Figure 4 - 4 Example of Output Assemble List

...				
A-X-	00000000		41	.file "c:\work\src\a.c"
A-X-	00000000		42	.align 4
A-X-	00000000		43	##BF
A-X-	00000000		44	.frame _main, .S2
A-X-	00000000		45	.globl _main
A-X-	00000000		46	_main:
A-X-	00000000		47	##B_PROLOGUE
A-X-	00000000	D505	48	jbr .L15
A-X-	00000002		49	.L16:
A-X-	00000002		50	.G17:
A-X-	00000002		51	.G18:
A-X-	00000002		52	.G9:
A-X-	00000002		53	.G11:
A-X-	00000002		54	.G19:
A-X-	00000002		55	##B_EPILOGUE
A-X-	00000002	23FF0100	56	ld.w -4+.F2[sp], lp
A-X-	00000006	441A	57	add .S2, sp
A-X-	00000008	7F00	58	jmp [lp] --0
A-X-	0000000A		59	##E_EPILOGUE
A-X-	0000000A		60	.L15:
A-X-	0000000A	5C1A	61	add -.S2, sp
A-X-	0000000C	63FF0100	62	st.w lp, -4+.F2[sp]
A-X-	00000010		63	##E_PROLOGUE
A-X-	00000010	95F0	64	jbr .L16
A-X-	00000012		65	##FUNC_ARG
A-X-	00000012		66	.G5:
A-X-	00000012		67	.set .S2, 0x4
A-X-	00000012		68	.set .F2, 0x4
A-X-	00000012		69	.set .A2, 0x0
A-X-	00000012		70	.set .T2, 0x0
A-X-	00000012		71	.set .P2, 0x0
A-X-	00000012		72	.set .R2, 0x0
A-X-	00000012		73	.set .X2, 0x0
...				
(1)	(2)	(3)	(4)	(5)

The parts of the assemble list lines are described below.

(1) Section attribute

These are section attributes for sections stored in the corresponding line. Section attributes and their meanings are described in the following table.

Table 4 - 3 Section Attributes and Their Meanings

Section Attribute	Meaning
A	Section occupying memory
W	Section that can be written
X	Executable section
G	Section allocated to memory area that can be referenced by using global pointer (gp) and 16-bit displacement

(2) Value of location counter

This is the location counter value for the beginning of the line of code.

(3) Code

This is the code, expressed as a two-digit hexadecimal number.

(4) Line number

This is the given line's line number, expressed as a decimal number.

(5) Source program

This is the assembly language source program on a given line. If instruction expansion is executed for the instruction on that line, the instruction string resulting from the instruction expansion is indicated following --.

The C language source program corresponding to that line's assembly source program is also displayed in this area.

4.7 Cautions

4.7.1 Magic number

Information indicating the target device for an object is automatically embedded into an object created by the as850. This information is called a "magic number". A model-specific magic number is embedded if only a particular type of device is the target device; if an entire core can serve as target devices, a "common magic number" is embedded.

An object that has been assembled by the as850 when the -cn option has been specified contains a common magic number and therefore can be linked to other objects for which a different device type has been specified as long as the specified device belongs to the same core (ld850 does not output an error when they are linked). As a result, any object that is created after the -cn option has been specified can be used as an object common to any device in the specified device's core.

Figure 4 - 5 Image of Creating Common Object with as850

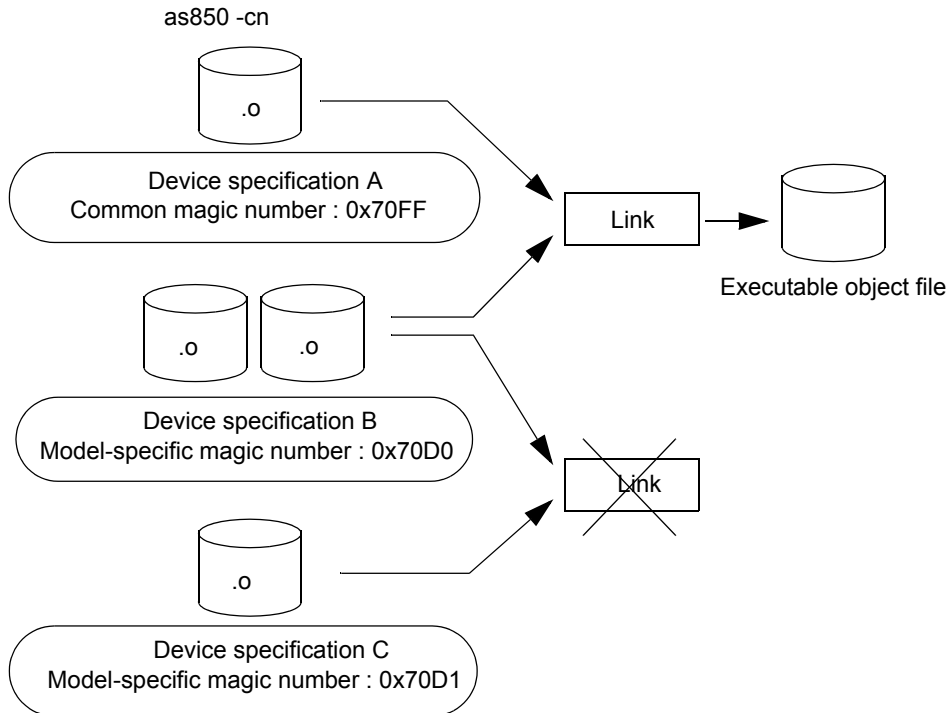

[Caution]

- Magic numbers common to cores and model-specific magic numbers are defined for various device files to establish associations among the device core. The as850 references the device files and embeds the magic numbers.
- Object files that operate device-specific peripheral function registers, etc., should not be used as common files among cores.
- If a target device is specified by the `-cpu` option or `.option quasi` directive and then the `-cn/-cnv850e/-cnv850e2` option is specified, a core common object including information peculiar to the target device can be created. However, an object having device-specific information different from that of the target device does not operate correctly. Check in advance that the device-specific information can be used with the intended target device.
- The V850Ex core is upwardly compatible with the V850 core. Source files that are used with the V850 core can be used with the V850Ex core.

In such cases, specify the `"-cn"` option or the `"-cnv850e"` option before creating an object.

The object common to V850 core that is created with `"-cn"` can be linked with a V850Ex core object.

Note that an object that is created with `"-cnv850e"` cannot be linked with a V850 core object.

- The V850E2 core is upwardly compatible with the V850 core/V850Ex core. Source files that are used with the V850 core/V850Ex core can be used with the V850E2 core.

In such cases, specify the `"-cn"` option, `"-cnv850e"` option or `"-cnv850e2"` option before creating an object.

The object common to V850 core/V850Ex core that is created with `"-cn"/"-cnv850e"` can be linked with a V850E2 core object.

Note that an object that is created with `"-cnv850e2"` cannot be linked with a V850 core/V850Ex core object.

Figure 4 - 6 Example of as850 CPU Core Compatibility (V850Ex Core and V850 Core)

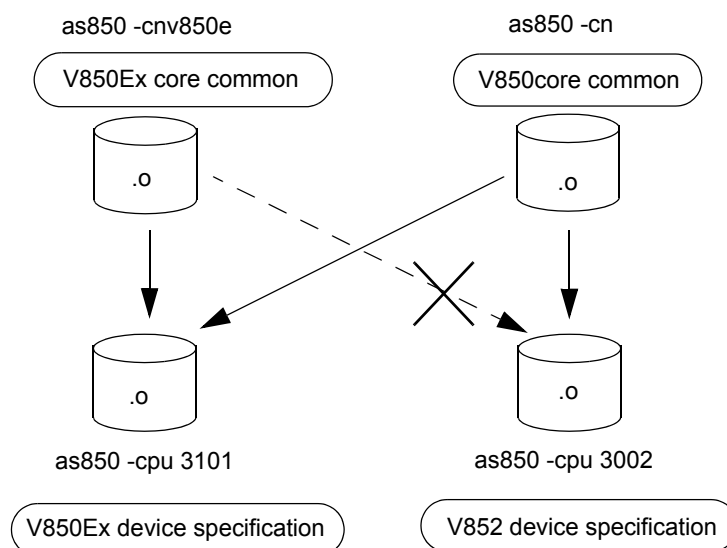

4.7.2 Options for avoiding CPU faults

The CA850 provides the `-Xv850patch` option for the `ca850` and the `-p` option for the `as850` to avoid faults from the V850 core/V850Ex core/V850E2 core CPU. When starting the `as850` from the `ca850`, if the `-Xv850patch` option is specified in the `ca850`, the `-p` option having the same *num* value is automatically set by the `as850` to the assembly language source file output by the `ca850`.

Specify the type of the code to be output (1 to 10 and 4a) as *num*. 1 to 4 and 4a are valid for the V850 core, and 5 to 10 are valid for the V850Ex core/V850E2 core only. If *num* is omitted, the following codes are identified from the device file and output.

- (1) If the target device is the V850E2 core or if V850E2 core common;[-cnv850e2] is specified as the magic number by an assembler option, code 5 to 10 is output.
- (2) If the target device is the V850Ex core or if V850E core common;[-cnv850e] is specified as the magic number by an assembler option, code 5 to 10 is output.
- (3) Code 1 to 4 is output if the target device is the V850 core.
- (4) If "V850 core common[-cn]" is specified as the magic number by an assembler option, code 1 to 10 is output.

[Note]

- To determine whether or not a fault that has occurred is from the CPU being used, refer to the CPU's documentation.
- If `-p` option and `as850` optimization option (`-O`) are specified at the same time when the target device of the V850 core is specified or if a V850 core common object is created, `-p` takes precedence and `-O` is ignored.
- If `-p` option and `as850` optimization option (`-O`) are specified at the same time when a target device of the V850Ex core/V850E2 core is specified or if a V850Ex core/V850E2 core common object is created, both `-p` and `-O` are valid.
- If a code pattern that generates a fault covers different sections, this option's function becomes invalid.
- Only the `-Xv850patch=11` option is handled by the `ca850`.
- The correspondence between CPU core and `-p` option is as follows (for the newest version μ PD70(F)3xxx, not including maintenance or obsolete products):

To check whether or not the failure affects the CPU used, refer to the CPU's documentation.

Table 4 - 4 Correspondence Between CPU Core and -p Option

CPU Core	-p1	-p2	-p3	-p4	-p4a	-p5	-p6	-p7	-p8	-p9	-p10
V850 core	OK	OK	OK	OK	OK	---	---	---	---	---	---
V850E/MS1	---	---	---	---	---	OK	---	---	A	---	A
V850E1 core	---	---	---	---	---	---	OK	OK	---	OK	---
V850ES core	---	---	---	---	---	---	---	---	---	---	---

Remark A : Affected

OK : Corrected (for the newest version μ PD70(F)3xxx, not including maintenance or obsolete products)

--- : Not affected

The types and meanings of *num* are as follows.

For the instructions and registers, refer to the relevant device's architecture manual.

(1) 1 (-Xv850patch=1 [-p1])

Insert a nop instruction immediately after the first ld.w in relation to the combination of "ld.w instruction + (st.[b|h|w]/sst.[b|h|w]/ld.[b|w]/sld.[b|w] instruction) + branch instruction".

Example

ld.w sst.w jarl	ld.w nop sst.w jarl
-----------------------	------------------------------

(2) 2 (-Xv850patch=2 [-p2])

Insert a nop instruction between the load/store instruction and branch instruction in relation to the combination of "ld.w/sld.w/st.w/sst.w instruction + branch instruction".

Example

ld.w jarl	ld.w nop jarl
--------------	---------------------

If the pattern of num=1 is processed at the same time, the pattern of num=2 is searched and processed first.

An unnecessary nop instruction does not need to be inserted.

(3) 3 (-Xv850patch=3 [-p3])

This inserts the clr1 instruction in relation to the corresponding interrupt control register immediately before the reti instruction.

Example

reti	clr1 5, P0IC0 reti
------	-----------------------

(4) 4 (-Xv850patch=4 [-p4])

This inserts a nop instruction immediately after the first load instruction in relation to the combination of "load instruction (ld.[b|h|w]/sld.[b|h|w]) + load store instruction (ld.[b|h|w]/sld.[b|h|w]/sst.[b|h|w]/st.[b|h|w])" (inserted when the peripheral I/O register has been accessed in the input file).

Example

ld.w ld.w	ld.w nop ld.w
--------------	---------------------

(5) 4a (-Xv850patch=4a [-p4a])

This inserts a nop instruction immediately after the first load instruction in relation to the combination of "load instruction (ld.[b|h|w]/sld.[b|h|w]) + load store instruction (ld.[b|h|w]/sld.[b|h|w]/sst.[b|h|w]/st.[b|h|w])" (inserted regardless of whether the peripheral I/O register is accessed or not).

Example

ld.w ld.w	ld.w nop ld.w
--------------	---------------------

-p4 sets patch 4 in cases where peripheral I/O access occurs in an input file. -p4a sets patch 4 regardless of whether or not peripheral I/O access occurs.

(6) 5 (-Xv850patch=5 [-p5])

This inserts a nop instruction in relation to the multiplication instruction immediately after it without any conditions.

Example

mulh jarl	mulh nop jarl
--------------	---------------------

(7) 6 (-Xv850patch=6 [-p6])

This inserts a nop instruction immediately after the load instruction in relation to the combination of "load instruction (ld.[b|h|w]/sld.[b|h|w]) + jr/jarl/jcond (bcond)"

Example

sld.bu jarl	sld.bu nop jarl
----------------	-----------------------

(8) 7 (-Xv850patch=7 [-p7])

This inserts a nop instruction immediately after the callt instruction. It also inserts the "mov r31, r0" instruction immediately before the switch instruction and reti instruction.

Example

switch	mov r31, r0 switch
--------	-----------------------

(9) 8 (-Xv850patch=8 [-p8])

This inserts a nop instruction between the consecutive sld instructions.

Example

sld.b sld.b	sld.b nop sld.b
----------------	-----------------------

(10) 9 (-Xv850patch=9 [-p9])

If instructions (a), (b), and (c) below exist in a row, a nop instruction is inserted immediately after the sld instruction (b).

Example

add sld and	add ... (a) sld.b ... (b) nop and ... (c)
-------------------	--

- (a) Of 2-byte instructions mov, not, satsubr, satsub, satadd, zxb, zxh, sxh, or, xor, and, subr, sub, add, shr, sar, and shl, instructions that write back to a register other than r0 and r30.

Example

add 0x1, r10

Including the instructions that describe a .set symbol with LABEL, expression, or definition after reference, and that are expanded to the above instructions.

Example

addi SYM, r10, r10
.set SYM, 0x123

This example is not a chip bug pattern but is subject to patching.

- (b) The sld instruction that writes back to a register different from those to which the instructions in (a) write back

Example

sld.b %LABEL, r11

- (c) An instruction that loads a value to the register to which the instructions (a) write back

Example

add r11, r10

Including the instructions that describe a .set symbol with LABEL, expression, or definition after reference, and that load a value to the register to which the instructions (a) write back

Example

```

    addi    LABEL2-LABEL1, r10, r12
LABEL1:
    -- (omitted)
LABEL2:
    
```

In this example, if the relative values of LABEL2 and LABEL1 exceed the range that can be expressed by 16 bits, the instructions are expanded as follows:

```

mov    LABEL2-LABEL1, r12
and    r10, r12
    
```

Instruction (b) is immediately followed by the move instruction, and the value of r10 is not loaded.

In other words, this example is not of a chip bug pattern but is subject to patching.

(11) 10 (-Xv850patch=10 [-p10])

This inserts a nop instruction immediately after the store instruction in relation to the combination of "store instruction (sst.[b|h|w]/st.[b|h|w]) + jcond(bcond)".

Example

<pre> sst.b br </pre>	<pre> sst.b nop br </pre>
-------------------------------	-----------------------------------

(12) No num specification (-Xv850patch [-p])

This outputs each code in the combination of 1 to 3 and 5 to 10, judged by the device file (refer to descriptions above). If this option is specified when creating an object that does not require a corresponding patch, no patch is set. The correspondence between created objects and options is shown below.

Table 4 - 5 Correspondence Between Created Objects and -p Options

Created Objects	-p1	-p2	-p3	-p4	-p4a	-p5	-p6	-p7	-p8	-p9	-p10
Specific to V850 directive	P	P	P	P	P	N	N	N	N	N	N
Specific to V850Ex directive	N	N	N	N	N	P	P	P	P	P	P
Specific to V850E2 directive	N	N	N	N	N	P	P	P	P	P	P
V850 core (common)	P	P	P	P	P	P	P	P	P	P	P
V850Ex core (common)	N	N	N	N	N	P	P	P	P	P	P
V850E2 core (common)	N	N	N	N	N	P	P	P	P	P	P

Remark P : Patched
 N : Not patched

CHAPTER 5 LINKER

This chapter presents an overview and describes the operation, link map, cautions, and output messages of the linker (ld850).

5.1 Flow of Operation

Generally, an application program is divided into several source files and coded. Source files written in C language activate the compiler (ca850) or assembler (as850) and source files written in an assembly language activate the assembler (as850) to output object files.

The linker (ld850) resolves the addresses of these object files in accordance with the information of the link directive and device files and generates one executable object file, i.e., a load module file. If there is external reference that is not resolved when the linker links object files, the linker searches the specified archive file (library file) to resolve the external reference. It then links only the object files necessary for resolving and generates executable object files. The linker can also generate relocatable object files when the -r option is specified.

Figure 5 - 1 Operation Flow of ld850

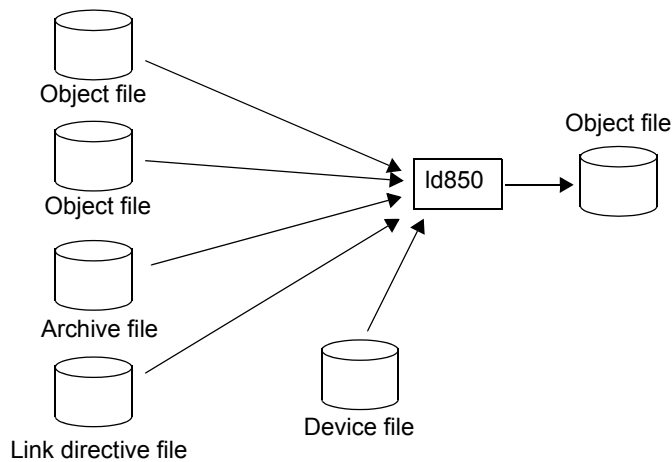
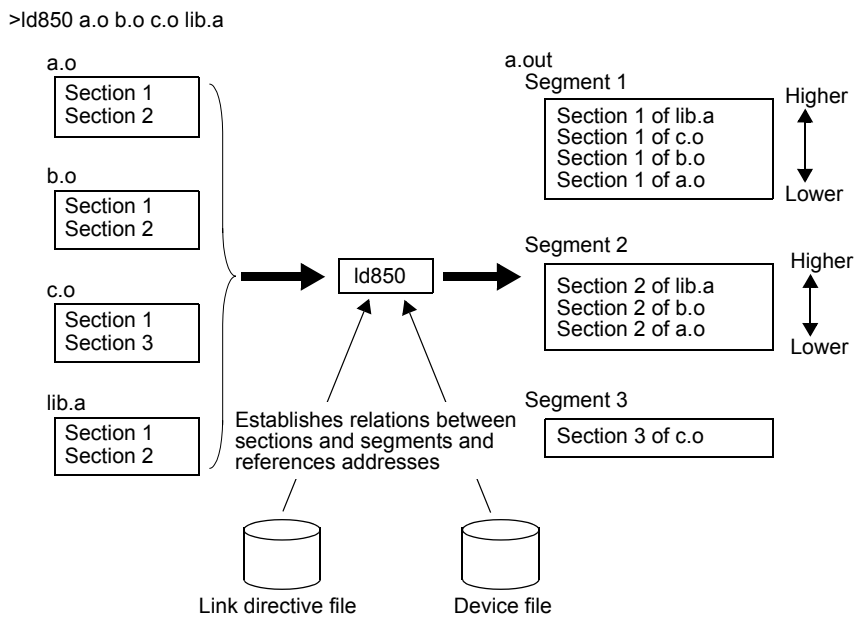

Figure 5 - 2 ld850 Operation Image (Example)



The ca850 internally activates the as850 and ld850 as drivers. When the ca850 is activated, a load module can be generated. Therefore, there is no need to be aware of activating the as850 and ld850.

Figure 5 - 3 Batch Processing

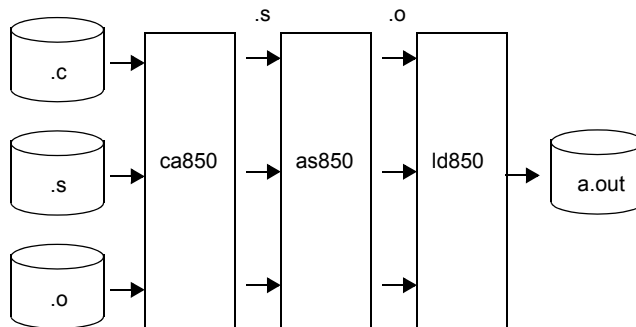
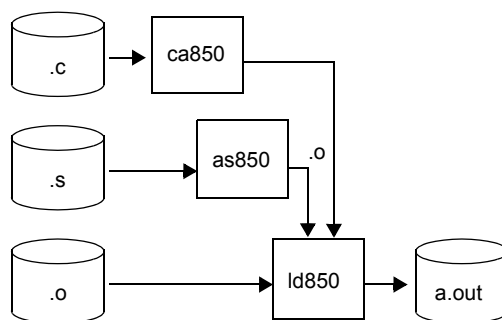

Figure 5 - 4 Modular Processing



5.1.1 Link procedure

The ld850's link procedure is described below.

- (1) The ld850 links a section (input section) that is included in a specified object file according to a link directive and device file to create an output section consisting of output object files.

Figure 5 - 5 Creation of Output Section

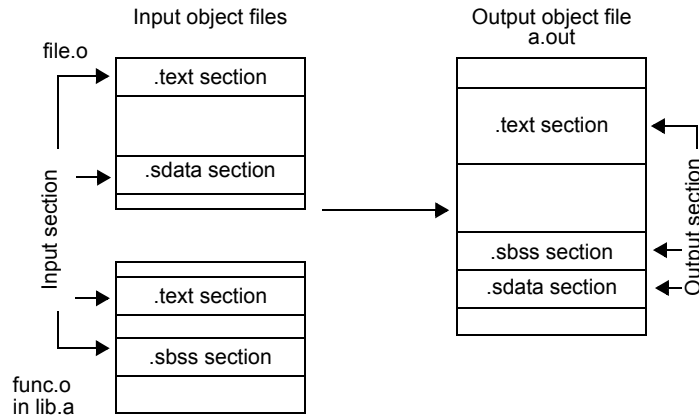

- (2) The ld850 links the output section created in the above-mentioned step according to the link directive and creates a segment^{Note}.

Note A segment is the minimum unit for loading a program to memory, and it is indicated in the program header of the created object file.

- (3) The ld850 allocates the segment created in the above-mentioned step to the target machine's memory space according to the link directive and device file.

Figure 5 - 6 Allocation to Memory Space

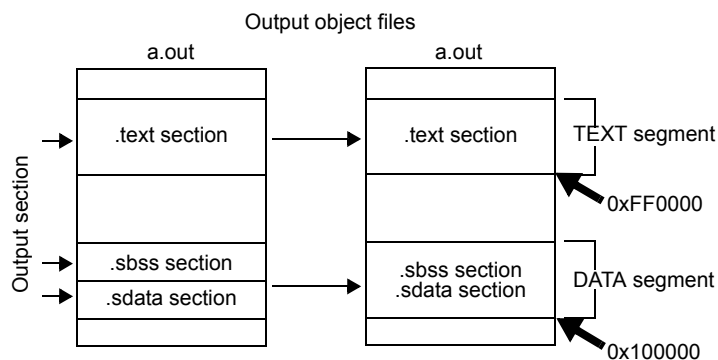

- (4) The ld850 resolves unresolved external references in the output section.
- (5) The ld850 creates the following three types of symbols according to the symbol directive in the link directive^{Note}.

- Text pointer symbol having the value set to the text pointer (tp)
- Global pointer symbol having the value set to the global pointer (gp)
- Element pointer symbol having the value set to the element pointer (ep)

Note These symbols are used to set appropriate values to the text pointer (tp), global pointer (gp), and element pointer (ep) before executing the codes created by the CA850 (such as in the start-up module). The element pointer symbol is set by the ld850 after it reads target device-specific values from a specified device file.

(6) The ld850 creates reserved symbols. These reserved symbols include the following.

- Start address of each output section
- Start address (with 4-byte alignment) of segment exceeding each output section
- Start address (with 4-byte alignment) of segment exceeding the created executable object file

For details of reserved symbols, refer to "[5.7.3 Reserved symbols](#)".

5.2 Operation Method

This section explains how to operate the ld850.

5.2.1 Command input method

Enter the following from the command prompt.

```
ld850 [option] ... file name [file name or option] ...  
[ ]: Can be omitted  
... : Pattern in preceding [ ] can be repeated
```

5.2.2 Method using PM+

The [\[Linker Options\] dialog box](#) that is used to set the linker options can be displayed via the following methods once a project has been established under PM+.

- Select [Tool] - [Linker Options...]

Since the linker is activated once per project, there are no file-specific settings.

The name of the executable object file that is output by the linker is a.out.

The default file name is a.out. To modify the name of the object file, specify a file name in "[Output File\[-o\]](#)" field on the [\[File\]](#) tab.

5.3 Types and Features of Options

The following tables list the ld850's options.

Some options which are listed on the following options are not in the PM+'s option dialog box. When one of these options must be specified, activate the ld850 from the command line.

[Symbols used in option list]

[V850E2]	Option dedicated to V850E2 core
[V850E]	Option dedicated to V850Ex core
[PM+]	Option exists as specification item under the PM+.

5.3.1 Input file

This sets an option related to the input file of the linker.

-D *dfile*

[PM+]

When this option is specified, links are made according to the link directive in the directive file *dfile*.

The length of *dfile* must be no more than 127 characters including the path specification or no more than 14 characters when not including the path specification. The extension is necessary, and .dir is recommended. If this option is omitted, the default link directive is used.

For description of the link directive's functions and organization, refer to CA850 for Link Directive User's Manual.

-Xolddir [=version]

[PM+]

This option selects the compatibility of the format of the link directive file with old versions.

"V240", "V250", or "V260" can be specified as *version*. If *version* is omitted, "V240" is assumed.

If this option is omitted, the latest link directive file format is supported.

- When V240 is specified
Section priority layout function OFF, segment sort OFF (equivalent to CA850 Ver. 2.40)
- When V250 is specified
Section priority layout function ON, segment sort OFF (equivalent to CA850 Ver. 2.50)
- When V260 is specified
Section priority layout function ON, segment sort ON (equivalent to CA850 Ver. 2.60 or later)

5.3.2 Output file

This specifies the files referenced and linked by the linker and an output file name.

+err_file=*file*

This option adds and saves error messages to the file *file*.

-err_file=*file*

This option overwrites and saves error messages to the file *file*.

-o *ofile*

[PM+]

This option specifies *ofile* as the name of the object file to be created. If this option is omitted, the default file name *a.out* is used.

-m [= *mapfile*]

[PM+]

This option outputs as a *mapfile* the link map that indicates the state of allocation to the memory space of the input and output sections. If *mapfile* is omitted, the link map is output to the standard output. For details of the link map, refer to "[5.5 Link Map](#)".

-mo [= *mapfile*]

[PM+]

This option outputs a link map that indicates allocation of the input and output sections to the memory space to *mapfile* in the format of products older than CA850 Ver. 2.60. If *mapfile* is omitted, the link map is output to the standard output.

5.3.3 Library

This specifies options related to libraries that are referenced by the ld850.

-ldir

[PM+]

If the `-l` option is specified with this option (or after this option in the case of the command line), the archive file (also called library file) specified by the `-l` option is searched, starting in the folder `dir` and then in the standard folders. The archive file specified by the `-l` option specified after this option is searched. If this option is omitted, only the standard folders are searched.

The ld850 handles the folder where the ld850 is installed, the folder at the position of `..lib850`, and the folder at the position of `..lib850\rXY` ($XY=[32|26|22]$) as the standard folders of libraries.

-lc

[PM+]

This option specifies whether or not to link the compiler's standard library(`libc.a`).

-lm

[PM+]

This option specifies whether or not to link the compiler's mathematical library(`libm.a`).

The mathematical library is valid when the `-lc` option is set because it also references the functions in the standard library.

-lstring

[PM+]

When resolving an unresolved external symbol reference, this option references the archive file `libstring.a`. If several archive files are specified by this option, the files are searched in the order of their specification.

- (1) Use no more than 64 characters to specify *string*.
- (2) When this option has been specified, the ld850 references only the archive files that are specified as having unresolved external references at the time they are specified. Therefore, when activating from the command line, specify this option after specifying the object file that will reference the specified archive files.
- (3) The mathematical library supplied by the CA850 references the `libc.a` file of the standard library. Therefore, specify standard library reference specification "`-lc`" after mathematical library reference specification "`-lm`" when the ld850 is activated from the command line.

5.3.4 Flash ROM

This specifies options related to the flash ROM of the Id850.

`-ext_table address`

[PM+]

This option creates an object file for the flash/external ROM relink function using the specified 8-digit hexadecimal address value as the start address value of the analysis table (Refer to "[5.6 Flash Memory/ External ROM Relink Function](#)").

- When specifying the boot area, the branch to the flash area side is processed as a branch using the branch table specified for the address that is specified by this option.
- During the flash area specification, a branch table having the branch instruction to the previous branch destination is created at the address specified by this option.
- The address value specified by this option must be the same as the value that is used when creating an object file in the boot area/flash area. If a different value is specified, operation faults will occur. There is no error checking.
- The address value specified by this option must be within the ROM area used as the flash area. No error checking is done because it is not possible to determine which area contains the specified address.
- When creating an object file in the flash area, this option automatically creates an `-ext_table` section having a size of "(the maximum ID value^{Note} + 1) x (Entry size of branch table)" and starting with the specified address value. Although there is no need to follow the directive file's allocation specification for this section, an empty area must be available for the section.
- This option cannot be specified with the `-x` option. Operation faults will occur if a relocatable object file that has been created using the `-x` option is input.

If this option is omitted, an object file for the flash/external ROM relink function will not be created.

Note This is the value specified by the `.ext_func` quasi directive in the assembly language source file.

-zf bootfile**[PM+]**

This option creates a flash-side object file from the specified object file as the boot area's object file when using the flash/external ROM relink function.

Specify the boot area's object file as the object file that was specified and created via flash/external ROM relink function.

If this option is omitted, a boot area object file is created.

The `-ext_table` option must be specified in order to use this option.

Example

```
ld850 -ext_table 0x200 -D dfile2 -zf boot.out -o flash.out flash1.o flash2.o
```

- (1) The object files `flash1.o` and `flash2.o`, which are generated from the assembly language source file that are processed for the flash/external ROM relink function are linked as objects in the flash area.
- (2) A branch table is created at address `0x200`.
- (3) When linking, the information in the boot area's executable object file `boot.out` is referenced. `boot.out` is not linked at this time.
- (4) Linking is performed according to the flash area's executable directive file.
- (5) The generated object file name is "flash.out".

5.3.5 Device

This specifies options related to the device of the ld850.

-x256M

[V850E] [PM+]

This option handles the memory space as a 256 M bytes space. If this option is not specified, the memory space is handled as a 64 M bytes space and addresses are resolved. Set this option in accordance with the chipset to be used. The physical address space of the V850Ex core has 256 M bytes in many cases. When creating an application that uses a space between 64 M bytes and 256 M bytes, specify this option.

-Xsid=id

[PM+]

This option sets the security ID of an on-chip flash memory device. It cannot be used if a device not supporting the security ID function is used.

Specify the ID in a hexadecimal number of 10 bytes or less (including the first 0x). If the specified value runs short of 10 bytes, the higher bits are filled with 0. If 10 bytes are exceeded, an error is output.

If the specification of a security ID is omitted for a device supporting the security ID function, it is assumed that "0xffffffffffffff" is specified.

If the security ID is set using a method other than the above, the compiler judges that the security ID is duplicated with the security ID that is generated by the linker, and outputs the following error.

```
F4264: start address(0x00000070) of section "SECURITY_ID" overlaps previous
section "section name" ended before address (0XXXXXXXXX).
```

In such a case, specify the +Xsid option to suppress security ID generation by the linker. If an object for a device not supporting the security ID function is specified when the linker is executed, a warning message is output and the specification is ignored.

For example, to set security code "0x112233445566778899aa" (setting 0x11 to address 0x70, 0x22 to address 0x71, 0x33 to address 0x72, 0x44 to address 0x73, 0x55 to address 0x74, 0x77 to address 0x76, 0x88 to address 0x77, 0x99 to address 0x78, and 0xaa to address 0x79), describe as follows.

```
-Xsid=0x112233445566778899aa
```

-Xob=none

This option suppresses the option byte that is generated by default.

Only the default generation by the initial value registered in the device file is suppressed. When specified by using .section "OPTION_BYTES" in the assembler source file, the .section "OPTION_BYTES" specification will be given priority, regardless of this option's specification.

Also, when this option is specified for devices that do not include option byte functionality, this option is ignored without outputting a message.

5.3.6 Option

This sets the ld850 options.

-A

[PM+]

This option outputs as a standard output the information that can be used as a guide for the [sdata/sbss Allocation] option (num setting of -Gnum option), which is specified for the ca850 and as850 when compiling or assembling source file. When using the value indicated by *OK*, data with a size less than that value is allocated to the sdata/sbss area.

When activating from the ca850, the -A option used in the ca850 activation is passed.

For details, refer to "[5.7.1 Using -A option](#)".

-B

[PM+]

This option executes linkage in two-pass mode.

If this option is omitted, linkage is executed in one-pass mode.

Although two-pass mode is slower than one-pass mode, it is able to process larger files.

-E

[PM+]

This option outputs a warning message, not an error message, and continues linking if any of the following illegalities is found during relocation processing.

- The result of address calculation of an unresolved external reference is illegal
- The relationship with the section to be allocated is illegal

The value of address calculation judged as illegal is not assigned to the unresolved external reference judged as an error; the original value remains.

-M

[PM+]

This option outputs a message for all external symbols that are defined more than once, and stops link processing.

If this option is omitted, a message is output only for the first external symbol that is defined more than once, and link processing is stopped.

-T

[PM+]

This option suppresses checking of the size and alignment condition when linking an external symbol.

If this option is omitted, the size is checked, and if a size difference is detected, a warning message is output and link processing is continued. At this time, the symbol size of the file in which the symbol is defined is valid.

-Ximem_overflow=warning

[PM+]

This option controls checking when the internal ROM/RAM overflows. In case of an overflow, a warning message is output and linking continues.

If this option is omitted, an error message is output and linking is stopped if an overflow occurs.

-e *symbol*

[PM+]

This is the entry point address value for the object file from which the symbol value *symbol* is created. If the specified symbol cannot be found, the linker outputs a message and link processing is stopped. When this option is not specified, the entry point address value is determined according to the following rules.

- (1) If the symbol `__start` exists, it is used.
- (2) If the symbol `__start` does not exist, the start address of the text attribute section that is allocated to the lowest address area in the created object file is used.
- (3) If the text attribute section does not exist, "0" is used.

The symbol name space cannot be left blank.

-f *num*

[PM+]

This option specifies the fill value for align holes between sections of the created object, with four-digit hexadecimal numbers (2 bytes). When using this option, specify `-B` option to execute linking in the 2-pass mode. `0x` at the beginning can be omitted. Specification by this option takes precedence over the fill value specification in the link directive.

- If the value does not occupy all four digits, it is assumed that zeros are used to fill the empty digit(s).
- If a hole does not cover two bytes, only the required number of digits are fetched and initialized from the specified fill value (starting from the lowest value).

If this option is omitted, the default specification `0x0000` is used.

-mc

[PM+]

This option checks whether or not the files that use the mask register function are mixed with files that do not use this function when linking the object files created from the C language source files. Link processing is stopped if they are found to be mixed.

-rc

[PM+]

This option outputs detailed information when use of register mode is mixed for all input object files.

If this option is specified with the `-w` option, this option is ignored. If this option is omitted, detailed information does not output.

-rescan

[PM+]

This option re-references the library file specified by the `-l` option. When this option is specified, symbols left unresolved because of the link sequence of the library can be prevented.

-rom_less**[PM+]**

This option suppresses checking of the internal ROM area. When the application allocation overlaps the addresses of the internal ROM area, a warning message is not output.

This option should be specified when the application has been created in ROM-less mode.

Caution Checking of the overflow of the internal ROM is not supported when the single-chip mode is selected. Invalidate checking of the overflow of the internal ROM and check the overflow on the link map.

-s**[PM+]**

This option creates an object file in which the debug information, line number information, and global pointer table have been removed.

-t**[PM+]**

This option suppresses checking of the symbol size and alignment condition when linking undefined external symbols. If this option is omitted, the symbol size and alignment condition are checked, and if a difference is detected, a warning message is output and link processing is continued.

- The linker supports multiple definitions of undefined external symbols. Multiple-defined undefined external symbols are allocated to the .sbss or .bss section after linking. If symbol sizes and alignment conditions to be linked vary, the maximum size and the least common multiple of the alignment condition are used.

-v**[PM+]**

This option outputs the detailed execution status of the ld850. It displays lists of objects to be linked.

-w**[PM+]**

This option suppresses output of warning messages. Only messages for fatal errors are output.

5.3.7 Other

This sets other options.

-F *devpath*

When the ld850 is started by itself, this option sets the device file search to begin in the *devpath* folder. If this option is omitted, the search goes directly to the standard folders. When activating from the ca850, use the ca850's `-devpath` option to specify the path of the device file. The ld850 handles the folder where the `-v`

This option outputs the ld850 version information as standard error output, then terminates.

-cpu *devicename*

This option specifies that the device file for the target device specified by *devicename* will be read. If using PM+, this corresponds to the device specification that is done when setting up a project.

If this option is omitted, the device file for the target device specified when the `.o` file was created will be read.

-fc

This option checks all input object files to see if the old function calling and the calling specification of the current version are used together.

The old function calling specification is not supported by the current version.

If this option is omitted, only the object files created from the C language source file are checked.

-help

This option outputs a help description of options as standard error output.

-mask_reg

This option references the mask register function's library. Use the `-Xmask_reg` option when activating from the ca850.

The mask register function's library is a 32 register mode library. When 22 register mode or 26 register mode has been specified, the following warning is output and any subsequent specification is ignored.

```
W4857: reg22" option is illegal when "-mask_reg" option is specified, ignored
"-reg22" option.
```

-r

This option creates a relocatable object file. This option is ignored if it is specified with the `-ro` option. If this option is specified, a message is not output and linking is completed normally even if an unresolved external reference remains at the end of linking. If this option is omitted and if an unresolved external reference remains, the following message is output and linking is stopped. In this case, an object file (load module file) is not generated.

```
F4452: undefined symbol.
      symbol referenced in "file"
```

If an object file created by the ld850 will be specified as the target for relinking by the ld850, specify this option when creating the target object file for relinking.

[Cautions]

- If this option has been specified, the link directive is valid only for the type and attribute in the mapping directive section and is otherwise ignored.
- If this option has been specified, the ld850 does not create any reserved symbols.
- The specification of the `-r` option has changed from CA850 Ver.2.30 or earlier. When using the mapping method of an old version, use `-r` instead of the `-ro` option.

-ro

This option creates a relocatable object file in the old mapping mode (CA850 Ver. 2.30 or earlier).

If this option is specified with the `-r` option, the `-r` option is ignored. If this option is omitted, an executable object file is created.

-regnum

This option references a register mode library. The 22 register mode, 26 register mode, or 32 register mode can be specified for `num`. Do not enter any blank spaces after `-reg`.

If this option is omitted, the 32 register mode library is referenced.

@cfile

This option handles `cfile` as a command file. A command file specifies an option and a file name for a command not as arguments on the command line but by describing them in a file. On Windows, the length of a character string specified as an option of a command is limited. If many options are set and some of the options cannot be recognized, create a command file and specify this option.

For details of the command file, refer to "[3.7.2 Command file](#)".

5.4 Settings Made via PM+

This section describes dialog boxes that are used to set the command options of the ld850 for the target project's source file.

5.4.1 [Linker Options] dialog box

At the upper part of this dialog box, the following four tabs are displayed.

The contents of this dialog box depend on selecting the following tab.

Figure 5 - 7 [Linker Options] Dialog Box

Tab	Description
[File]	Setting of options related to files
[Library]	Setting of options related to library
[Option]	Setting of linker options
[Others]	Other settings

Note The option shown with "[]" in this dialog box is the option that is activated from the command line.

[File]

This tab is used to set options related to files of the linker.

Figure 5 - 8 [Linker Options] Dialog Box ([File] Tab)

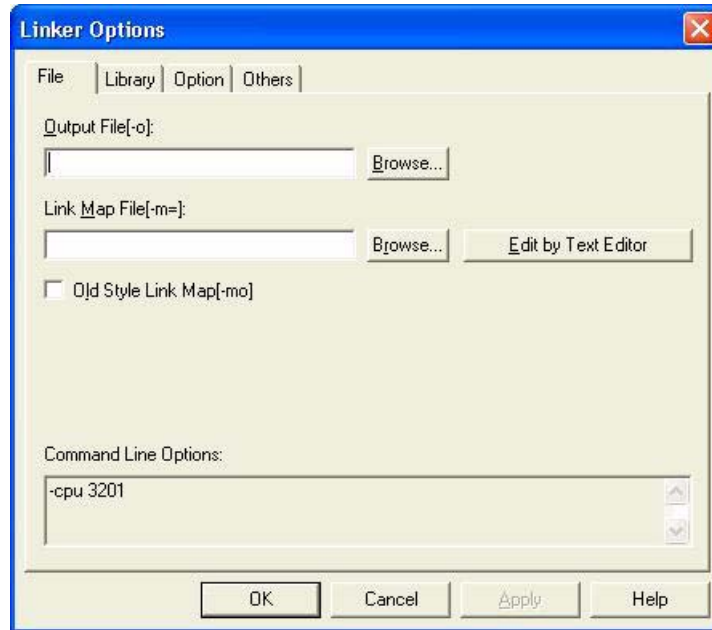

(1) Output File[-o]

This field is used to specify the name of the object file (with extension ".out") to be output. If this option is omitted, it is assumed that a.out is specified.

A file can also be selected by using the dialog box that is displayed by selecting the [Browse...] button.

(2) Link Map File[-m=]

This option specifies the name of the output file when a link map is output. A file can be selected by using the dialog box that is displayed by selecting the [Browse...] button.

By selecting the [Edit by Text Editor] button, the text editor can be displayed and the link map file can be edited.

Note that this setting takes precedence over "Output Link Map[-m]" check box on the [Option] tab.

(3) Old Style Link Map[-mo]

This check box specifies whether the link map of an old version is to be output. If this box is checked, the link map file specified by "Link Map File[-m=]" is output in the old format.

(4) Command Line Options

This area displays the options set in this dialog box by command line options.

This area is for reference and cannot be written to.

[Library]

This tab is used to set options related to library of the linker.

Figure 5 - 9 [Linker Options] Dialog Box ([Library] Tab)

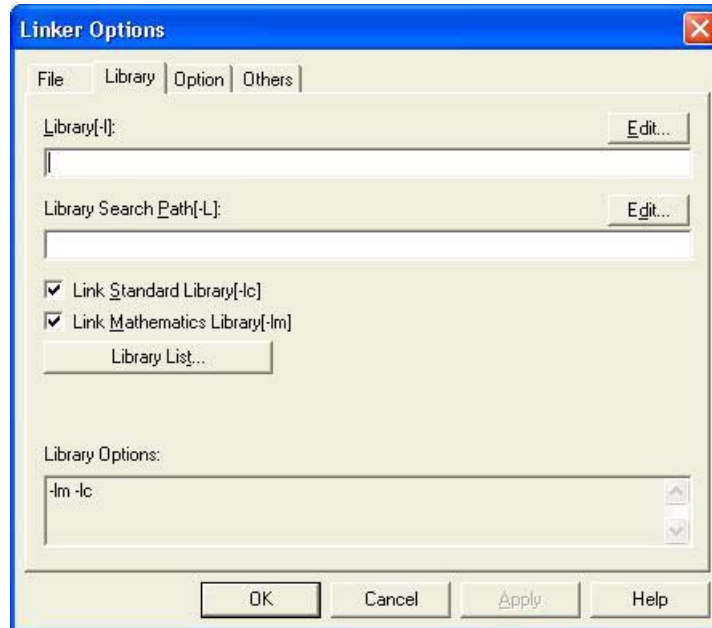

(1) Library[-I]

This option specifies the string portion of the archive file (library file) libstring.a to be accessed. When specifying several files, delimit each name with a semicolon ";". Selecting the [Edit...] button displays the [Edit Option] dialog box, where the library items can be edited. The archive file is searched in the folder specified by "Library Search Path[-L]" and the standard.

(2) Library Search Path[-L]

This specifies the folder where the archive file (library file) to be accessed is stored. When specifying several folders, delimit each name with a semicolon ";". Selecting the [Edit...] button displays the [Edit Option] dialog box, where the path items can be edited. If a folder is specified by this option, the library is searched from the specified folder before the standard folders of the library. If two or more folders are specified, the library is searched in the sequence in which the folders were specified in the text box.

(3) Link Standard Library[-lc]

This check box is used to reference the standard library "libc.a" provided in the package. This check box is selected as the default setting.

(4) Link Mathematics Library[-lm]

Because the mathematics library references the standard library, also check the standard library as a reference library. The library reference is automatically specified after the input object file, and the standard library is linked after the other libraries. The path of a library is automatically specified before the library reference. rompct.o, which is necessary for ROMization, is automatically linked after a library. This is to place the rompct section for ROMization after the .text section of the other input files.

(5) Library List

When this button is clicked, a list of libraries to be linked specified by the options currently set on this page is displayed.

Figure 5 - 10 [Library List] Dialog Box

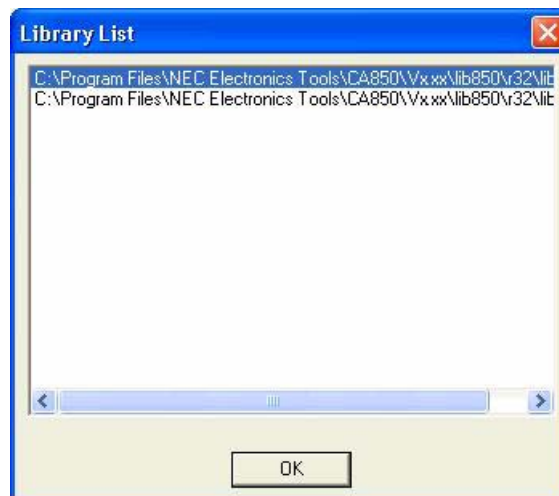
**(6) Command Line Options**

This area displays the options set in this dialog box by command line options.
This area is for reference and cannot be written to.

[Option]

This tab is used to set options of the linker.

Figure 5 - 11 [Linker Options] Dialog Box ([Option] Tab)

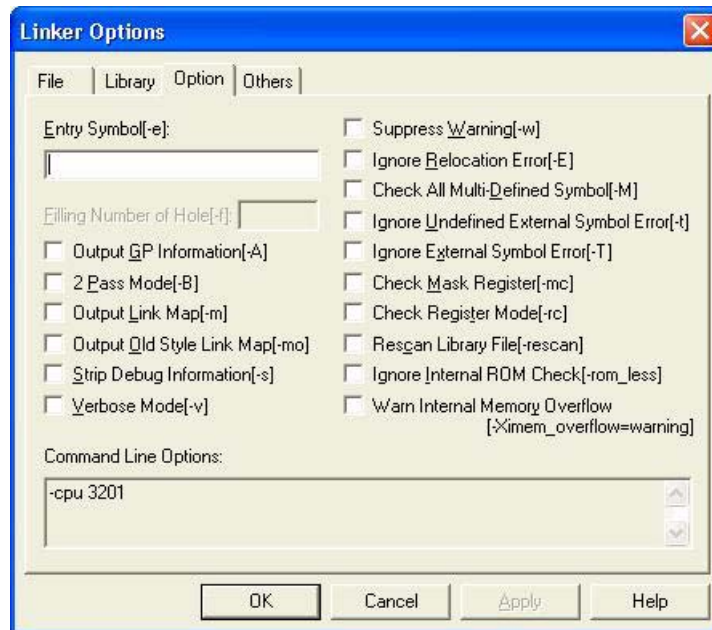

(1) Entry Symbol[-e]

This text box is used to specify a symbol to be set as the entry point address. If the specified symbol is not found, the linker outputs a message and stops linking. This area uses a drop-down list type of display to list all symbol names that have been specified once (up to 10 symbol names). Either click on the desired symbol name or use the arrow keys to select it.

If this option is not specified, the entry point address value is determined by the following rules.

- Value of `__start` (two underscores) symbol if that symbol exists.
- The start address of the text-attribute section allocated to the lowest part in the object file created if `__start` symbol does not exist.
- 0 if the text-attribute section does not exist.

(2) Filling Number of Hole[-f]

This specifies the fill value for the created hole in the object as a 4-digit hexadecimal number (2 bytes). When using this option, specify "2 Pass Mode[-B]" to execute linking. 0x at the beginning can be omitted. Specification by this option takes priority over the fill value specified by the link directive file.

If the value is less than 4 digits, prefix it with zeros to fill. If the size of the hole is less than 2 bytes, take out the required number of low-order digits from the specified fill value. If the fill value specification is omitted, the default value 0x0000 is used.

(3) Output GP Information[-A]

This option outputs information to the standard output that can be used as criteria in setting numeric values in the "Size Threshold of sdata/sbss Section Allocation[-G]" option set in the [Output Code] tab of the [Compiler Options] dialog box or [Option] tab of the [Assembler Options] dialog box when compiling or assembling a source file. If data displayed as "**OK*" is used, data for which the size is that numeric value or less is allocated to the sdata/sbss data area. The displayed results are included in the log file (project name + .plg) that is generated automatically in the project folder.

(4) 2 Pass Mode[-B]

This check box is used to specify whether linking is to be executed in the 2-pass mode specified by the -B option.

(5) Output Link Map[-m]

This option outputs a link map to the standard output that shows the allocation of memory space in the input and output sections. The link map that is output is included in the log file (project name + .plg) that is generated automatically in the project folder.

Remark If an output file name was specified in "Link Map File[-m=]" on the [File] tab, output to the file takes precedence and this option is void.

(6) Output Old Style Link Map[-mo]

This option specifies whether the link map of an old version is to be output. Its effect is the same as "Old Style Link Map[-mo]" on the [File] tab.

(7) Strip Debug Information[-s]

This option creates an object file from which the debug information, line number information, and global pointer table have been stripped.

(8) Verbose Mode[-v]

This option displays the detailed execution status of the as850 on the Output window.
It displays lists of objects to be linked.

(9) Suppress Warning[-w]

This option suppresses output of warning messages. Only messages concerning fatal errors will be output.

(10) Ignore Relocation Error[-E]

This option outputs a warning message and allows linking to continue if any of the following illegalities is found during relocation processing.

- The result of address calculation of an unresolved external reference is illegal
- The relationship with section to be allocated is illegal

The value of address calculation judged as illegal is not assigned to the unresolved external reference judged as an error; the original value remains.

(11) Check All Multi-Defined Symbol[-M]

This option outputs a message for all external symbol duplicate definitions and stops linkage. If this option is omitted, a message is output only for the first duplicate encountered and linkage is stopped.

(12) Ignore Undefined External Symbol Error[-t]

This option ignores checking of size and alignment conditions during linkage of undefined external symbols. If this option is omitted, symbol size and alignment conditions are checked. If a difference is found, a warning message is output and linking continues.

Remark The linker supports multiple definitions of undefined external symbols. The multiple, undefined external symbols are allocated to the .sbss or .bss section after they have been linked. If the symbol size or alignment condition of the symbols to be linked differ, the maximum size of the symbols to be linked is used as the size and the least common multiple of the alignment condition is used as the alignment condition.

(13) Ignore External Symbol Error[-T]

This option suppresses size checking when linking external symbols. If this option is omitted, the size is checked, and if a difference in size is detected, a warning message is output and linking continues. At that point, the symbol size of a file for which a symbol is actually defined is valid.

(14) Check Mask Register[-mc]

This option checks whether or not files that use the mask register function are mixed with files that do not use this function when linking object files created from the C language source files. If mixed, linking is stopped.

(15) Check Register Mode[-rc]

This option checks whether or not different register modes are mixed among all of the input object files, and outputs detailed information if mixed. If the "Suppress Warning" check box is checked, this option cannot be selected.

(16) Rescan Library File[-rescan]

This option specifies whether the library file specified by "[Library\[-l\]](#)" on the [\[Library\]](#) tab is to be rescanned.

When this option is specified, symbols left unresolved because of the link sequence of the library can be prevented.

(17) Ignore Internal ROM Check[-rom_less]

This option does not check the location for the internal ROM area. This option does not output a warning message to the address of the internal ROM area even if the application allocations are overlapped.

Specify this option in the ROMless mode. Unnecessary warning messages will not be output.

(18) Warn Internal Memory Overflow[-Ximem_overflow=warning]

This option controls checking when the internal ROM/RAM overflows. In case of an overflow, a warning message is output and linking is continued. If this option is omitted, an error message is output and linking is stopped if an overflow occurs.

(19) Command Line Options

This area displays the options set in this dialog box by command line options.

This area is for reference and cannot be written to.

[Others]

This tab is used to set other options of the linker.

Figure 5 - 12 [Linker Options] Dialog Box ([Others] Tab)

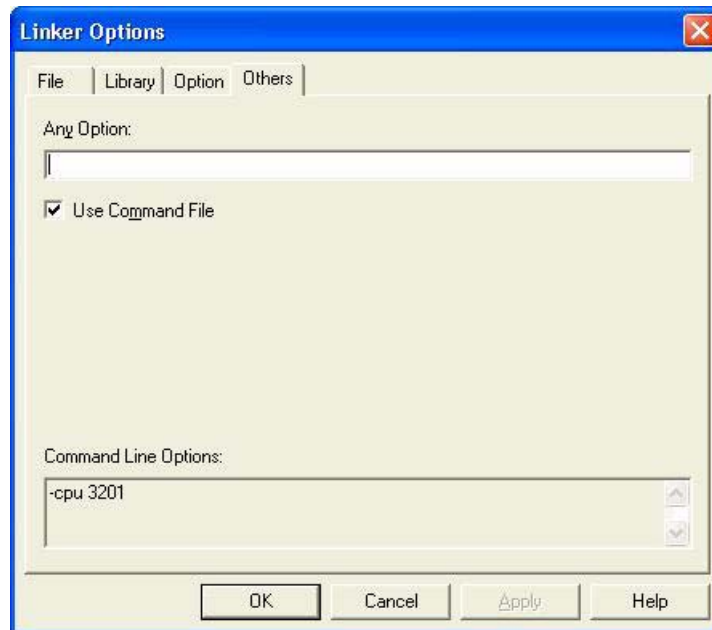

(1) Any Option

This edit box is used to specify an option other than those described above in the [\[Linker Options\] dialog box](#). Describe an option in this edit box in the same manner as on the command line. At present, it is not necessary to use other options because all the options related to the linker can be set on the [\[Linker Options\] dialog box](#).

(2) Use Command File

In the Windows environment, the length of character strings used to specify options for the ca850 is restricted. If this check box is selected, the option character string is output to a command file, which enables the operation to be completed without observing the restriction on the character string length. Check this check box if many options are set and not all of them can be recognized. Under the default setting, the check box is not checked.

For the details of command file, refer to "[3.7.2 Command file](#)".

(3) Command Line Options

This area displays the options set in this dialog box by command line options.

This area is for reference and cannot be written to.

5.5 Link Map

This section describes the link map output by the ld850.

A link map is where link result-related information is written. It can be referenced for information such as a section's allocation addresses.

Link map output methods are described below.

5.5.1 When starting the ld850 from the command line

If the link map's display option (-m) has been specified, link map is output when linking is completed. Since output is via standard output, use the console's redirect function to set file output.

If the -mo option is specified, display in the old format of CA850 Ver. 2.60 or earlier.

A file name is specified as the -m=*file* option or the -mo=*file* option to output to a file.

5.5.2 When starting from PM+

Go to the [Tool] - [Linker Options...] menu and select the [Option] tab, then check the "Output Link Map[-m]" option to set link map output. The output destination is the specified file if file output has been specified, or if not, the PM+'s output window.

5.5.3 Link map output example

Link map output examples are shown below. [Figure 5 - 13](#) shows an example of the link map that is output when object files have been linked.

[Objects]

crtN.o

main.o

func.o

libc.a (standard library)

[Link Map Output]

Figure 5 - 13 Link Map Output Example

***** MEMORY ALLOCATION MAP *****				
OUTPUT SEGMENT	SEGMENT ATTRIBUTE	VIRTUAL ADDRESS	SIZE(16)	SIZE(10)
TEXT	RX	0x00000000	0x00000082	130
DATA	RW	0x00000088	0x00000018	24
(1)	(2)	(3)	(4)	(5)
***** LINK EDITOR ALLOCATION MAP *****				
OUTPUT SECTION	INPUT SECTION	VIRTUAL ADDRESS	SIZE	INPUT FILE
.text		0x00000000	0x00000082	
	.text	0x00000000	0x0000001a	crtN.o
	.text	0x0000001c	0x0000002c	main.o
	.text	0x00000048	0x00000018	func.o
	.text	0x00000060	0x00000022	strcmp.o(../lib850/r
.sdata		0x00000088	0x0000000e	
	.sdata	0x00000088	0x0000000e	main.o
.sbss		0x00000098	0x00000008	
	.sbss	0x00000098	0x00000004	func.o
	.sbss	0x0000009c	0x00000004	*(GpCommon) *
(6)	(7)	(8)	(9)	(10)

"MEMORY ALLOCATION MAP" in the link map displays the following information.

(1) Output segment

Names of output segments configuring the object file to be generated (names of the output segments are not stored)

(2) Segment attribute

R	Read
W	Write
X	Executable

(3) Address

Start address of the output segment

(4) Size (hexadecimal)

Size of the memory including the alignment conditions between sections and the align hole (hexadecimal)

(5) Size (decimal)

Size of the memory including the alignment conditions between sections and the align hole (decimal)

"LINK EDITOR ALLOCATION MAP" of the link map displays the following information.

(6) Output section

Section name output to the load module (displayed up to 12 characters)

(7) Input section

Name of input section configuring output section (displayed up to 12 characters)

(8) Address

The start address of output section or input section

(9) Size

Size of output section or input section

(10) Input file

Object file names belonging to an input section

If an area is allocated by using the .comm quasi directive of the as850, the area is common to all the files, and its section is displayed as `"*(Common)*"` or `"*(GpCommon)*"`. If the object file to which the input section belongs is an object file in an archive file (library), the archive file is displayed as the full path name in the following format.

- Object file name (archive file name)

If display in the old format of CA850 Ver. 2.60 or earlier is specified by using the -mo option, `*(nil)*` is displayed for the section created with the ld850, and sections created with the as850 such as .symtab, .strtab, and.shstrtab.

Remark `*(nil)*`

`*(nil)*` may appear in the data areas of the .sbss and .sdata sections. This indicates that a globally declared variable without an initial value has been allocated. Even if a variable with the same name is used for a different file, it is still inevitably part of the load module, so the file name containing the variable becomes undefined and therefore appears as `*(nil)*` in the link map. However, if data without an initial value was declared using the #pragma section "data" instruction, the file name appears instead of `*(nil)*` since the file's allocation is identified.

5.6 Flash Memory/External ROM Relink Function

5.6.1 Relink function

Some systems are equipped with flash memory or detachable ROM. To upgrade the version of the program, the contents of the flash memory may be rewritten or the detachable ROM may be replaced with a new ROM. When changing the program even partially, basically the project itself is reorganized or "rebuilt". However, it would be convenient if the allocation to be upgraded was limited to the flash memory or external ROM and if it was not necessary to reorganize the project.

The boot area is fixed to the internal ROM. If a function is called between the flash memory to be rewritten and the boot area, and if the start address of the function is changed as a result of modifying the function in the flash memory, the function cannot be called correctly.

The "flash memory/external ROM relink function" (hereafter referred to as the "relink function") is used to prevent this and enable functions to be called correctly.

This function is realized as follows.

- (1) A "branch table" where instructions to branch to the functions in the flash memory area are written is prepared in the flash memory area.
- (2) When a function in the flash memory area is called from the boot area, execution jumps to the branch table in the flash memory area, and then the instruction used to branch to the intended function is executed and jump occurs.

This mechanism can be realized by the user. If the "relink function" is used, this can be done relatively easily. To use this function, however, the functions to be called in the flash memory area must be determined when the fixed ROM area is created. This mechanism is used to call a function from the fixed ROM area even if the function is modified in the flash memory area.

5.6.2 Image of relink function

A function is called as shown below when the relink function is used.

(1) To call function in fixed ROM from fixed ROM

The function can be called without problem because addresses have been resolved before they are programmed to the fixed ROM.

Figure 5 - 14 In Fixed ROM

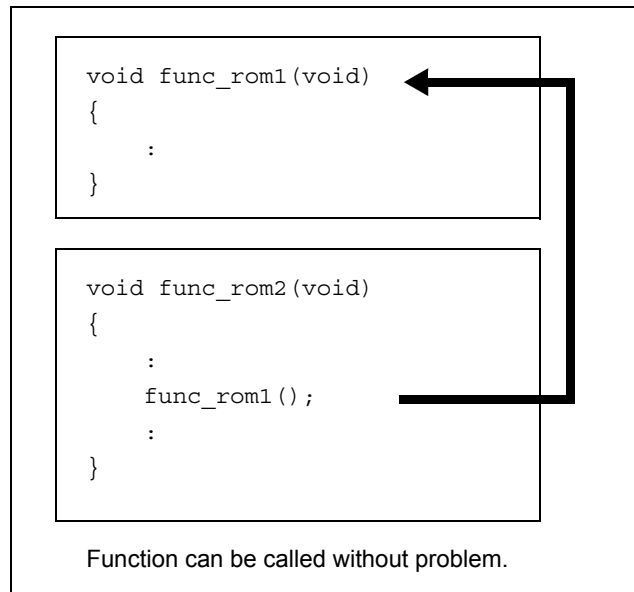

(2) To call function in flash memory from flash memory

The function can be called without problem because addresses have been resolved in the flash memory.

Figure 5 - 15 In Flash Memory

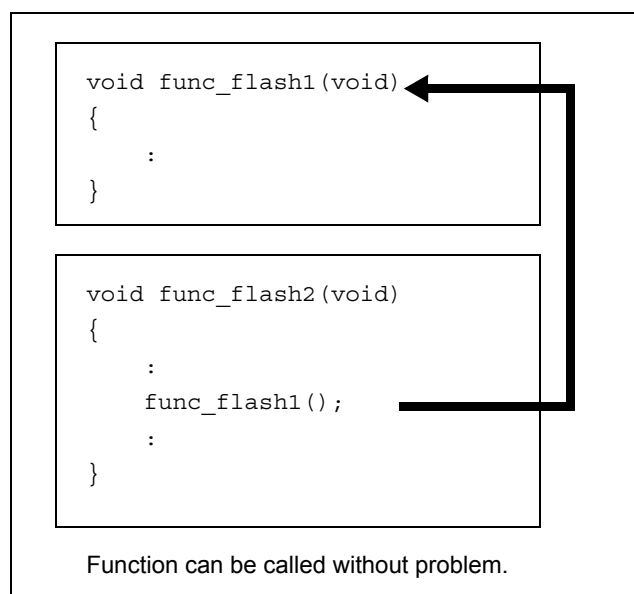

(3) To call function in flash memory from fixed ROM

When a function in the flash memory is called from the fixed ROM, the address of the function cannot be known from the fixed ROM because the function size, etc., have been changed in the flash memory. In other words, a function in the flash memory cannot be directly called. To solve this, execution jumps to the branch table in the flash memory. From this table, an instruction that jumps execution to the function in question is executed. In this way, execution jumps to the intended function.

Figure 5 - 16 From Fixed ROM to Flash Memory

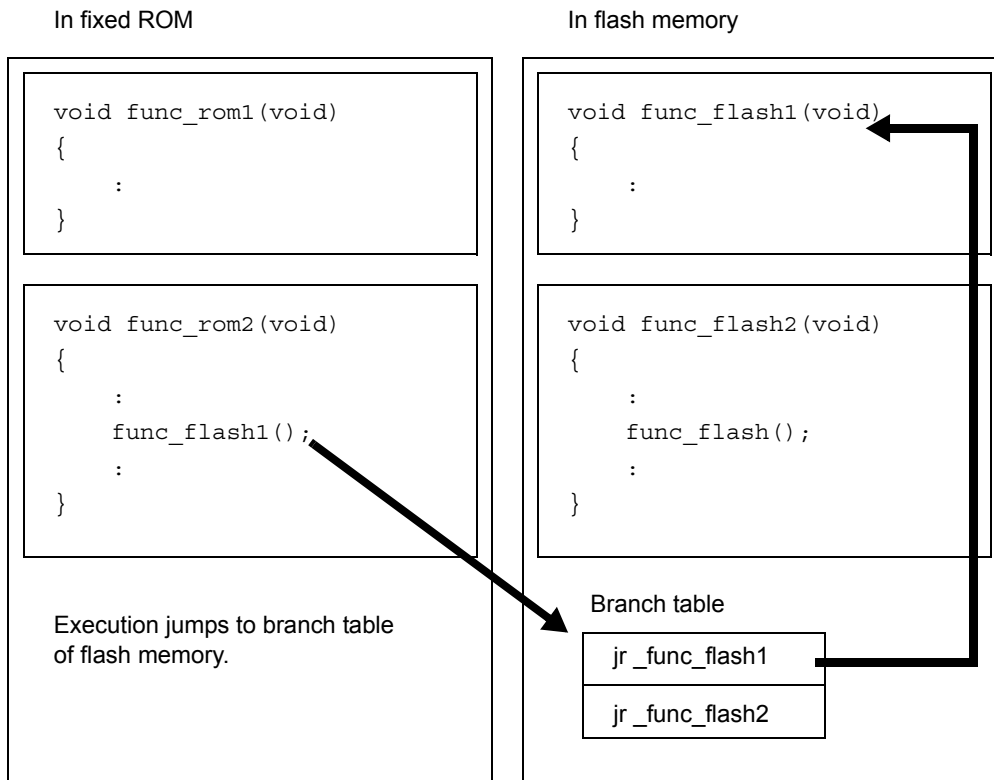

In the same manner as functions, this is relevant to referencing external variables.

A global variable defined in the flash memory cannot be referenced from the fixed ROM. Therefore, an external variable of the same name can be defined in both the fixed ROM and flash memory. Each of these external variables is referenced only from the respective areas.

(4) To call function in fixed ROM from flash memory

When a function in the fixed ROM is called from the flash memory, the contents of the fixed ROM are not changed. Therefore, a function in the fixed ROM can be directly called from the flash memory.

Figure 5 - 17 From Flash Memory to Fixed ROM

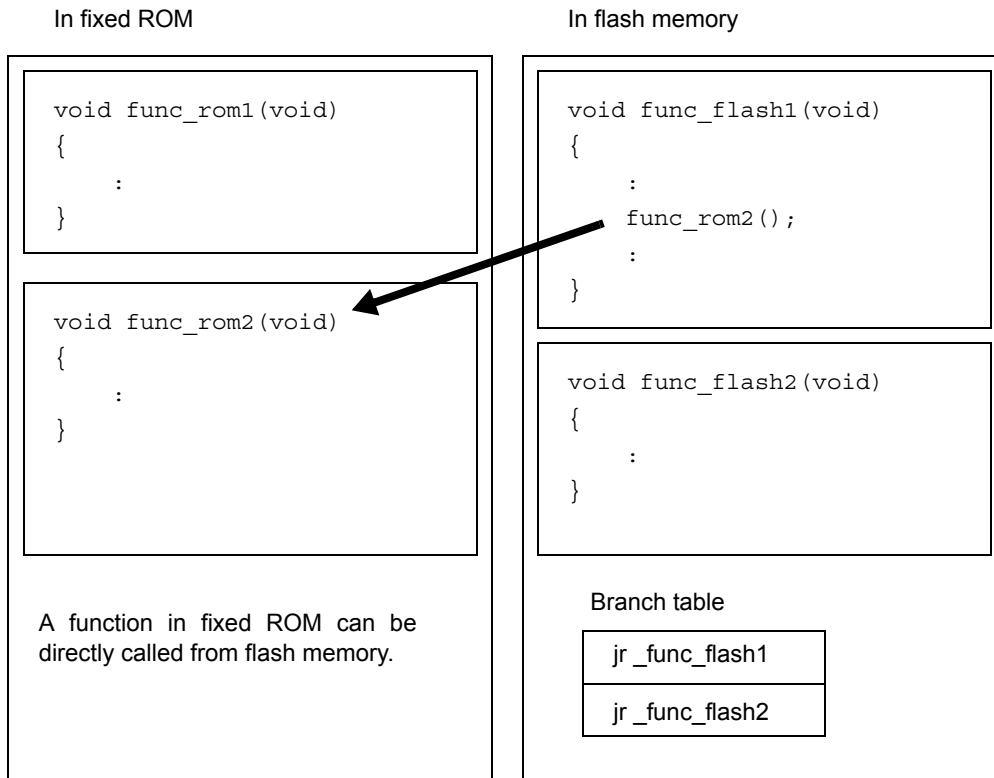

In the same manner as functions, this is relevant to referencing external variables. A global variable defined in the fixed ROM can be referenced from the flash memory.

5.6.3 Realizing relink function

This section describes specifically how to realize the relink function.

(1) Project of PM+

To realize the relink function, a fixed ROM area and flash memory area must be separately created. This means that only the flash memory area is modified after the fixed ROM area has been created (after a program has been stored in ROM). When creating a project with PM+, therefore, divide the project as follows.

- (a) Project to be allocated to the fixed ROM area
- (b) Project to be allocated to the flash memory area (project that may be modified in the future)

In addition, separately prepare a startup routine and link directive file for each project.

(2) .ext_func quasi directive

When calling a function in the flash memory area from the fixed ROM area, the name of the function to be called (label name) and ID number are assigned to the fixed ROM area by using the .ext_func quasi directive. The format of the .ext_func quasi directive is as follows.

```
.ext_func function-name, ID-number
```

Specify a positive number as the ID number. A different ID number must not be specified for the same function name or the same ID number must not be specified for different function names.

When a function name in the flash memory area is specified in the fixed ROM area by using the .ext_func quasi directive, a branch table (ext_table) is created. The address of this ext_table is specified by the user.

Specify the address as follows, by using linker option "-ext_table", when a load module of the internal ROM area and a load module of the flash memory area are created.

```
-ext_table address /* address to be specified */
```

When execution branches to the body of a function, the actual function address is obtained by referencing the offset of the ID number from the beginning of the created branch table, and then execution branches.

Example

```
func_flash0()
func_flash1()
func_flash2()
```

If the above three C functions are allocated to the flash memory and they are called from the fixed ROM, describe as follows in the fixed ROM using the as850.

```
.ext_func _func_flash0, 0
.ext_func _func_flash1, 1
.ext_func _func_flash2, 2
```

To make this description in a C language source file, use the `#pragma asm - #pragma endasm` directives or `__asm()`. When the `#pragma asm - #pragma endasm` directives are used, the description looks as follows.

```
#pragma asm
    .ext_func _func_flash0, 0
    .ext_func _func_flash1, 1
    .ext_func _func_flash2, 2
#pragma endasm
```

It is recommended to describe these `.ext_func` quasi directives in one file and include this file in all source files by using the `.include` quasi directive (or `#include` directive when describing in C language), in order to prevent missing descriptions or the occurrence of contradictions, i.e., to prevent the error of specifying different ID numbers for the same function names or specifying the same ID number for different function names. If a file using the `#pragma asm - #pragma endasm` directives is included as above, the compiler outputs the following message but this may be ignored (or set by "Individual Warnings" not to output this message).

```
W2244: '#pragma asm' used out of function is not supported completely.
```

An image of the relink function is shown below.

Assembly language source described by user	Assembler image after linking
<pre>[ext_table.inc] .ext_func _func_flash0, 0 .ext_func _func_flash1, 1 .ext_func _func_flash2, 2</pre>	
<pre>[rom.s] .include "ext_table.inc" .extern _func_flash0 .extern _func_flash1 .extern _func_flash2 jarl _func_flash0, lp jarl _func_flash1, lp jarl _func_flash2, lp</pre>	<pre>[rom.out] .extern __ext_table_head jarl __ext_table_head+0x4*0,lp jarl __ext_table_head+0x4*1,lp jarl __ext_table_head+0x4*2,lp</pre>
<pre>[flash.s] include "ext_table.inc" .globl _func_flash0 .globl _func_flash2 _func_flash0: : jmp [lp] .globl _func_flash1 _func_flash1: : jmp [lp] _func_flash2: : jmp [lp]</pre>	<pre>[flash.o] #(branch table) .section ".ext_table", text .globl __ext_table_head .extern _func_flash0 .extern _func_flash1 .extern _func_flash2 __ext_table_head: jr _func_flash0 jr _func_flash1 jr _func_flash2 #(function body) .globl _func_flash0 _func_flash0: : jmp [lp] .globl _func_flash1 _func_flash1: : jmp [lp] .globl _func_flash2 _func_flash2: : jmp [lp]</pre>

If the `.ext_func` quasi directive is specified as shown above, a table is created with the symbol `ext_table`, and the first symbol of this table is `__ext_table_head`.

Code `"jarl__flash0, lp"` in the fixed ROM is an offset from `__ext_table_head`, and obtains the address of `__flash0` and jumps to the function body by the `jarl` instruction.

(3) Startup routine

Separately prepare a startup routine for the fixed ROM and a startup routine for the flash memory. Each startup routine must perform the following processing.

- (a) Setting tp, gp, and ep values in the fixed ROM
- (b) Calling the `_rcopy` function to initialize the RAM area to be used for the fixed ROM
- (c) Branching from the fixed ROM to the startup routine of the flash memory
- (d) Calling the `_rcopy` function to initialize the RAM area to be used for the flash memory
- (e) Moving to the processing of the flash memory

If tp, gp, and ep are not used in the fixed ROM, the values may be set in the flash memory. When the initial value data is copied by using the `_rcopy` function, the load module must be "ROMized" by the ROMization processor. Prepare `rompctr.o` having the first symbol of the `rompsec` section and execute linking by specifying the linker option `-lr`. By using the packing section created as a result, copy data with an initial value by using the `_rcopy` function (refer to "[CHAPTER 6 ROMIZATION PROCESSOR](#)").

It is recommended to use the same address values in the fixed ROM and flash memory for the tp, gp, and ep values. These values may be different, but in this case the values must be set each time control has been transferred between an instruction code in the fixed ROM and one in the flash memory.

Fixed ROM	Flash memory
<pre> __start: mov #__tp_TEXT, tp mov #__gp_DATA, gp mov #__ep_DATA, ep : # To main function in fixed ROM # It is not necessary to stick to # the name "main function". jarl _main, lp .ext_func _flash_start 3 jr __flash_start </pre>	<pre> .ext_func _flash_start 3 jr __flash_start __flash_start: : # To main function in flash memory jarl _main, lp </pre>
<pre> extern unsigned long _S_romp; void main(void) { _rcopy(&_S_romp, -1); : } </pre>	<pre> extern unsigned long _S_romp; void main(void) { _rcopy(&_S_romp, -1); : } </pre>

(4) Describing link directive file

Each of the fixed ROM and flash memory projects has a link directive file. The following points should be noted when describing a link directive file.

- (a) Even if the address of a section placed in the RAM area overlaps in the fixed ROM and flash memory, the linker does not output an error because the projects are different. In other words, the addresses can overlap. For the RAM area that must be referenced simultaneously in the fixed ROM and flash memory, addresses must be specified so that they do not overlap.
- (b) It is recommended to use the same address values for the tp, gp, and ep values in the fixed ROM and flash memory. These values may be different, but in this case the values must be set each time control has been transferred between an instruction code in the fixed ROM and one in the flash memory.
- (c) A link directive file related to the branch table (ext_table) does not have to be described. It is automatically allocated to an address specified by the linker option "-ext_table". However, the following points must be noted.
 - If a vacant area of the size of the branch table is at the address specified by -ext_table, the link directive file is allocated as is. The other segments are not affected. This is the most ideal case.
 - If a vacant area of the size of the branch table is not at the address specified by -ext_table, an error occurs. This applies, for example, if a code has been already allocated to the address specified by -ext_table in a TEXT segment for which an address is specified. Here is an example.

Address specification of branch table

```
-ext_table 0x500
```

Link directive file (part)

```
TEXT : !LOAD ?RX V0x400 {
    .text = $PROGBITS ?AX .text;
};
```

(Size of TEXT segment is 0x100 bytes or more.)

An error occurs as a result of linking because the branch table cannot be allocated to address 0x500. Change the value specified by -ext_table.

- If another segment is allocated to the address specified by `-ext_table` before the relink function is used but the address of that segment is not specified in the link directive file, the branch table is allocated to the address specified by `-ext_table` and the original segment is moved behind the branch table. If the segment overlaps a segment for which an address is specified as a result of moving, however, an error occurs.

Address specification of branch table

```
-ext_table 0x500
```

Link directive file (part)

```
TEXT : !LOAD ?RX {  
    .text = $PROGBITS ?AX .text;  
};
```

(It is assumed that the TEXT segment is allocated from address 0x500 as a continuation from the segment ahead of the TEXT segment.)

At this time, the branch table is allocated to address 0x500 because no address is specified for the TEXT segment, and the TEXT segment is allocated behind the branch table.

(5) Assembler and linker options

To assemble an object in the flash memory, specify the assembler option "-zf". When the as850 alone is activated, this option is specified. When it is activated from PM+, the assembler option "-zf" is automatically appended if "Create Flash Object" of the Compiler Common Options is checked and an object file of the fixed RAM is specified by "Boot Object File". Specify an object output by the ld850. An error occurs if an object output by the romp850 is specified. Specify "Branch Table Address (ext_table) (-ext_table option)" as a linker option. Specify an address of the flash memory. An example where the address of the branch table is 0x200000 is shown below.

Figure 5 - 18 Compiler Common Options for Flash Memory

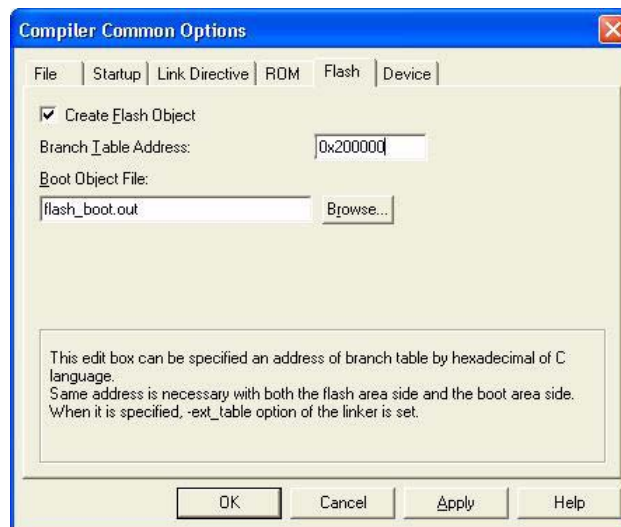

Check "Create Flash Object" also for a project of the fixed ROM, but do not specify "Boot Object File (-zf option)". Specify the same address as the flash memory for "Branch Table Address (ext_table) (-ext_table option)". An example of option setting for the fixed ROM is shown below.

Figure 5 - 19 Compiler Common Options for Fixed ROM

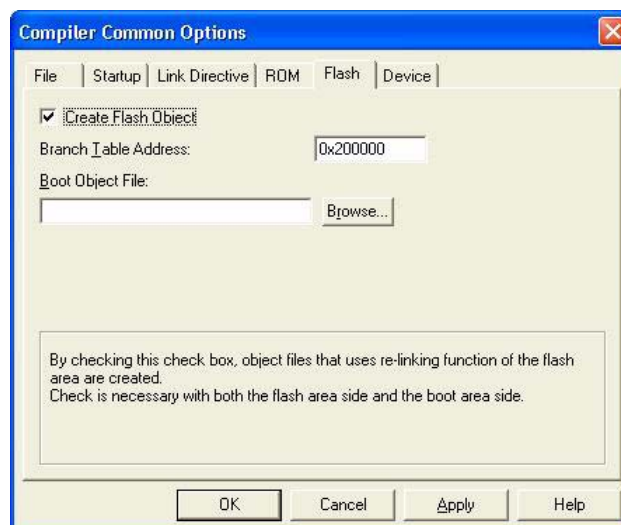

(6) .ext_ent_size quasi directive

When an actual function is called from the branch table in the flash memory, jr branch instructions are output as follows by default.

```
__ext_table_head:
    jr _func_flash0
    jr _func_flash1
    jr _func_flash2
```

However, the jr instruction can branch only within a 22-bit range because of a restriction of the architecture. To branch in the entire 32-bit space, additionally specify the .ext_ent_size quasi directive. The format of this directive is as follows.

```
.ext_ent_size size          -- Entry size of table
```

The value that can be specified as the entry size is "4", "8", or "10". "Entry size of table" above means "instruction size necessary for one branch processing". The default entry size is "4". In this case, a 4-byte instruction is allocated as follows.

```
jr _flash_func0           -- 4-byte instruction
```

If "8" is specified, a total of 8 bytes of instructions are allocated, as follows.

```
mov #_flash_func0, r1     -- 6-byte instruction
jmp [r1]                  -- 2-byte instruction
```

If "10" is specified, a total of 10 bytes of instructions are allocated, as follows.

```
movhi hi1(_flash_func0), r0, r1 -- 4-byte instruction
movea lo(_flash_func0), r1, r1  -- 4-byte instruction
jmp [r1]                        -- 2-byte instruction
```

Note that an 8-byte instruction can be used only when the V850Ex core/V850E2 core is used (because only the V850Ex supports this instruction set).

When creating an object common to the V850 core/V850Ex core/V850E2 core (when using the -cn option), always specify "10".

(7) Library

If a library function is called from the fixed ROM or flash memory, the library is linked to the object on the calling side. For example, even if a library is linked to the flash memory, the same library is linked to the fixed ROM if the same library function is called from the fixed ROM. When a library function is called, therefore, a function does not have to be specified by the `.ext_func` quasi directive for the library function because branching does not take place between the fixed ROM and flash memory. In a special case where the library linked to the fixed ROM branches to a function in the flash memory, however, a function must be specified by the `.ext_func` quasi directive.

For the "standard library" and "mathematical library" of the CA850 package, a function does not have to be specified by using the `.ext_func` quasi directive.

(8) Interrupt handler

Describe the part that calls an interrupt handler in the area where the address of the interrupt handler exists. In the following case, an interrupt handler function name must also be specified by the `.ext_func` quasi directive.

- Interrupt handler address is in fixed ROM.
- Interrupt handler body is in flash memory.

Assembly language source described by user	Assembler image after linking
<pre>[ext_table.inc] .ext_func _int_flash0, 0</pre>	
<pre>[rom.s] .include "ext_table.inc" .extern _int_flash0 .section "INT00", text jr _int_flash0</pre>	<pre>[rom.out] .section "INT00", text jr __ext_table_head+0x4*0,lp</pre>
<pre>[flash.s] .include "ext_table.inc" .globl _int_flash0 _int_flash0: : ret</pre>	<pre>[flash.o] # (branch table) .section ".ext_table", text .globl __ext_table_head .extern _int_flash0 __ext_table_head: jr _int_flash0 # (handler body) .globl _int_flash0 _int_flash0: : ret</pre>

5.7 Supplementary Information

This section describes the supplementary points related to the ld850.

5.7.1 Using -A option

This section describes how to use the -A option.

With PM+, specify "Output GP Information[-A]" on the [Option] tab of the [Linker Options] dialog box for the -A option.

-A

[Function]

This option displays the following information that serves as a yardstick for the value to be set to num of the -Gnum option that can be specified for the ca850 and as850 when a source file is compiled or assembled.

- Standard output if ca850 or as850 has been activated with the -A option specified on the command line
- Output window if "Output GP Information[-A]" is specified with PM+

The -Gnum option allocates data of less than num bytes to the .sdata or .sbss section. The ca850 and as850 output codes in compliance with the following rule for the data allocated to the sdata, sbss, data, and bss areas.

The ca850 or as850 first tries to allocate the data to the sdata section or sbss section, which are areas that can be accessed with a single instruction from the gp register (data with an initial value is allocated to the sdata section and data without an initial value is allocated to the sbss section).

Because these areas are accessed by a code that uses gp and a 16-bit displacement for access, data can be allocated only in a range of ± 32 KB from gp. If the data does not fit in these areas, the ca850 or as850 tries to allocate the data to the data section or bss section, which are areas that can be accessed with two instructions from the gp register (data with an initial value is allocated to the data section and data without an initial value is allocated to the bss section). In these areas, the address of the access area is first generated, and a code using gp and a 32-bit displacement for access is generated. Consequently, the entire 4 GB space can be accessed.

Figure 5 - 20 Memory Allocation Image of gp Offset Reference Section

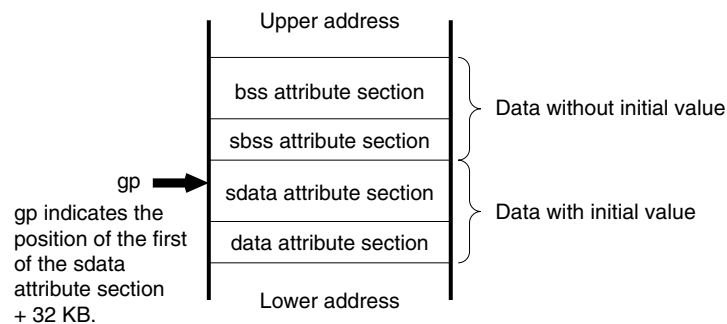

Therefore, the execution efficiency and object efficiency are enhanced if more data is allocated to the sdata or sbss section, which can be accessed with a single instruction.

To allocate data, the user can intentionally specify the allocation location by using the #pragma section directive in the case of a C language source or by using the .section quasi directive in the case of an assembly language source. If a threshold value of the size of the data to be allocated to the sdata or sbss section is prepared and if data of a size less than the threshold value can be allocated to the sdata or sbss section, more data can be allocated without having to modify the source program. This specification is made by the -Gnum option of the ca850 or as850.

The value specified as num of this option is the data size, so it would be convenient to have information that can be used as a yardstick. The -A option outputs this information. If the -A option is specified for the ld850, it outputs information that can serve as a yardstick for determining the value of num of the -Gnum option.

[Explanation of output information]

An example of the information output when this option is specified when an executable object file is generated without the -r option specified and an example of the information output when this option is specified when a relocatable object file is generated with the -r option specified are shown below.

Figure 5 - 21 Example of Output Information on Executable Object File

***** LINK EDITOR GP INFORMATION *****					
GP SYMBOL NAME	SECTION NAME	SECTION SIZE (REAL)	SECTION SIZE (ASSUMED)	GP NUMBER	
_gp_DATA	.sdata	0x000af10	0x00002000	4	*OK*
			0x00003450	8	*OK*
			0x00004430	12	*OK*
			0x000050a8	16	*OK*
			0x00007b40	20	*OK*
			0x0000a010	24	
			0x0000af10	32	
			.sbss	0x00012050	0x00000050
	0x00002050	16			*OK*
	0x00007050	512			*OK*
	0x00010050	1024			
	(a)	(b)	(c)	(d)	(e)

Figure 5 - 22 Example of Output Information on Relocatable Object File

***** LINK EDITOR GP INFORMATION *****					
GP SYMBOL NAME	SECTION NAME	SECTION SIZE (REAL)	SECTION SIZE (ASSUMED)	GP NUMBER	
(NOT AVAILABLE)					
	.sdata	0x000af10			
			0x00002000	4	*OK*
			0x00003450	8	*OK*
			0x00004430	12	*OK*
			0x000050a8	16	*OK*
			0x00007b40	20	*OK*
			0x0000a010	24	
			0x0000af10	32	
	.sbss	0x00012050			
			0x00000050	4	*OK*
			0x00002050	16	*OK*
	GpCommon	0x00010000			
			0x00005000	512	*OK*
			0x00010000	1024	
(a)	(b)	(c)	(d)	(e)	(f)

The meaning of each item of the output information is as follows:

(a) Name of global pointer symbol

This is the name of the global pointer symbol used for linking. If the created object file is a relocatable file, "(NOT AVAILABLE)" is displayed.

(b) Section name

This is the name of the sdata attribute section or sbss attribute section to which data are allocated. Because a relocatable object file cannot determine allocation of an undefined external symbol to a section, the ld850 internally creates a virtual section "*GpCommon*" and temporarily allocates the data to this section.

(c) Actual size of section

This is the actual size of the section that is considered for use as the area for the hole generated by data alignment.

(d) Assumed size of section

This is the size of the section that is assumed if the ca850 is started with the *-Gnum* option specified (with the value shown in the column at the right to this column specified as *num*). Because the calculation of this size assumes an alignment condition of more than 4 bytes without taking the actual alignment condition into consideration, the value shown in this column does not necessarily agree with the actual size of the created section.

(e) Value of num of *-Gnum* option assumed

This is the value of the *-Gnum* option num upon starting the ca850 and the as850 that is assumed as a result of calculating the "assumed size of section" shown on the column to the left of this column.

(f) Judgement result

This is the result of the judgment^{Note} as to whether or not the size of the section is within a range of 15 bits (0x0 to 0x7fff) if the ca850 is started with the *-Gnum* option specified with the value shown in the column at the left to this column (specified as *num*). If the size is within this range, **"*OK*"** is displayed; if it is not, nothing is displayed.

Note Usually the sections to which data is allocated are allocated from the lower address in the order of data/sdata/sbss/bss attribute sections in CA850. The global pointer (*gp*) is assumed to be set in the startup module, etc. so as to indicate the first address of the sdata attribute section + 32 KB. If the result is OK in this judgement, the sdata/sbss attribute sections are assumed to be allocated to a memory range that can be referenced using 16-bit displacement.

[Cautions]

- The information output by this option is only a guide, and the judgment result may not be correct, such as in the following cases:
 - (a) If allocation of a section that creates a hole is specified by a link directive, etc.
 - (b) If a direct address is specified for a global pointer symbol.
 - (c) If data is allocated to the .sdata/.sbss section by the #pragma section directive.

Example

```
> ld850 -A file1.o file2.o
```

file1.o and file2.o are linked and information that can be used as a guide for setting the *num* value of the *-Gnum* option that can be specified for the ca850 or the as850 when compiling or assembling is output via standard output.

5.7.2 Archive files

An archive file is created by linking two or more object files with the archiver (ar850).

When an archive file is specified, the ld850 searches the archive file for unresolved external references^{Note 1} and links only the necessary object files.

The archive file can be also specified via the link directive's mapping directive. If the archive file is also specified in the mapping directive, it is searched for unresolved external references at that time and only the necessary object files^{Note 2} are linked.

Notes 1 The archive file includes a symbol table of the symbols belonging to the archiver's object files, and the archive file is repeatedly searched as long as unresolved external references remain unresolved.

2 Object file that defines a referenced symbol.

5.7.3 Reserved symbols

During link-related processing, the ld850 creates reserved symbols whose values include the start address of each output section, the start address beyond the end of each output section, and the start address beyond the end of a created executable object file.

If the user defines a symbol having the same name as any of these reserved symbols, the ld850 uses the defined symbol, and does not create its own symbol.

A symbol having a name made by prefixing "__s" to the name of the output section is used as a reserved symbol that has the start address of a section as a value. If this section name begins with ".", "." is taken out and "__s" is prefixed to make it a symbol name.

A symbol name with "__e" prefixed to the name of that output section is used as a reserved symbol that has the start address beyond the end of a section as a value. If the section name begins with ".", however, the "." is stripped and "__e" is prefixed so that the name becomes a symbol name.

__end is used as a reserved symbol having a start address beyond the end of a created executable object file.

The default link directive used by the ld850 uses the following reserved sections as output sections.

Table 5 - 1 Reserved Section

.text,	.pro_epi_runtime,	.data,	.sdata,
.sbss,	.bss,	.sconst,	.const,
.sedata,	.sebss,	.sidata,	.sibss,
.tidata,	.tibss,	.tidata.byte,	.tibss.byte,
.tidata.word,	.tibss.word		

Therefore, the ld850 normally creates the following reserved symbols.

Table 5 - 2 Special Symbols in Ordinary Object File

__end,	__ebss,	__econst,	__edata,
__epro_epi_runtime,	__esbss,	__esconst,	__esdata,
__esebss,	__esedata,	__esibss,	__esidata,
__etext,	__etibss,	__etibss.byte,	__etibss.word,
__etidata,	__etidata.byte,	__etidata.word,	__sbss,
__sconst,	__sdata,	__spro_epi_runtime,	__ssbss,
__ssconst,	__ssdata,	__ssebss,	__ssedata,
__ssibss,	__ssidata,	__stibss,	__stibss.byte,
__stibss.word,	__stidata,	__stidata.byte,	__stidata.word

Caution Of the above symbols, only those for which a section exists in the executable file after link processing are generated. The ld850 behaves as if no section exists if a section that is actually allocated does not exist even if a mapping directive is described in the link directive file.

5.7.4 May not be allocated to the expected sections

Even if a directive file specifies an object file or archive file to be allocated to a section, the object file or archive file may or may not be allocated to the expected sections, depending on how the file name is described.

In such cases, refer to the link map [-m] and specify the directive file with the file name displayed on the link map and with the identical name including the path name, then relink.

5.7.5 V850 core and V850Ex core

The V850Ex is upward-compatible with the other V850 core microprocessors. Source programs used for the V850 core can be used for the V850Ex. In this case, create the V850 core object file as an object file common to the core with the as850 option.

An object file created as "common to V850E" cannot link with a non-V850Ex object file (refer to "4.7.1 Magic number").

5.7.6 V850 core and V850E2 core

The V850E2 is upward-compatible with the other V850 core microprocessors. Source programs used for the V850 core can be used for the V850E2. In this case, create the V850 core object file as an object file common to the core with the as850 option.

An object file created as "common to V850E2" cannot link with a non-V850E2 object file (refer to "4.7.1 Magic number").

5.7.7 Mathematics library

An error such as an undefined symbol error may be output even when a mathematics library function is used in a program and a mathematics library (libm.a) is subsequently linked. This relates to the linking sequence with the standard libraries. Since this sequence must comply with the ANSI standard, the standard libraries should be linked last. Note this with caution, especially when starting the linker from the command line. Describe the options in the order of the -lm and the -lc.

5.7.8 main function

If linking is performed without first creating a main function, an error message may be output to indicate that the `_main` symbol is an undefined symbol.

This may occur when the user links the default startup routine (crtN.o or crtE.o[V850Ex]) rather than a user-specified startup routine, or when the crtN.s or crtE.s source files that are provided with the package are used as they are for assembly and linkage.

The error is due to the "jarl _main, lp" code that is written following crtN.s or crtE.s. If the main function is not needed, the user should overwrite this code then use the reassembled object as the startup routine.

5.7.9 Prologue/epilogue runtime library

The prologue/epilogue runtime library must be allocated to the special-purpose `.pro_epi_runtime` section. If it is not allocated there, the linker outputs the following message and stops linking.

```
F4286: section ".pro_epi_runtime" must be specified in link directive.
```

If a link directive file has been specified, enter the mapping directive before the `.text` section.

```
.pro_epi_runtime = $PROGBITS ?AX .pro_epi_runtime;  
.text = $PROGBITS ?AX;
```

If the `.pro_epi_runtime` section is placed after the `.text` section, it will overlap during ROMization under the ROMization processor's default operation for packed sections. Placing the `.pro_epi_runtime` section before the `.text` section is recommended. If a link directive file has not been specified, link before the `.text` section.

[Cautions]

- The prologue and epilogue runtime libraries are included in standard library `libc.a`.
- Unlike ordinary sections, the `.pro_epi_runtime` section has a fixed input section name and only the special-purpose section is allocated.
- If the `.pro_epi_runtime` section is allocated after the `.text` section, it overlaps the allocation position of the default operation of the section that is packed during ROMization. Allocate the `.pro_epi_runtime` section before the `.text` section.
- The prologue and epilogue runtime libraries use the `callt` instruction when a device of the V850Ex core is used. Set CTBP in the startup routine.

5.7.10 Linking for ROMization

For ROMization, the packing section area must be considered when coding the link directive. Refer to "[CHAPTER 6 ROMIZATION PROCESSOR](#)".

ROMization is not possible if the default link directive and the CONST segment are both used. Since the default link directive allocates the CONST segment immediately after the TEXT segment, the packed section (rompsec section) and the CONST segment become overlapped during the ROMization processor's default operation. Perform one of the following responses while considering the additional sample directive^{Note} attached to the package.

Note "v850def.dir/v850def2.dir//v850def3.dir" stored in "install folder\smp850\ca850".

v850def.dir	Sample using internal ROM/RAM and external RAM
v850def2.dir	Sample using only internal ROM/RAM
v850def3.dir	Sample using internal ROM/RAM, external RAM, and internal instruction RAM (such as V850E/ME2)

Memory allocation must suit the microprocessor being used.

Place the CONST segment before the TEXT segment.

```
CONST : !LOAD ?R {
    .const = $PROGBITS ?A .const;
};

TEXT : !LOAD ?RX {
    .text = $PROGBITS ?AX;
};
```

Reserve a packed section area (refer to "[CHAPTER 6 ROMIZATION PROCESSOR](#)") after the TEXT segment and place the CONST segment after that reserved section.

```
TEXT : !LOAD ?RX {
    .text = $PROGBITS ?AX;
};

#
# [ Packed section area ]
#

# Address specification takes packed section into account.
CONST : !LOAD ?R V0x200000 {
    .const = $PROGBITS ?A .const;
};
```

5.7.11 Programmable peripheral I/O register

For an application program that uses programmable peripheral I/O register functions, a .bpc section (which is a reserved section) is output when assembling. If there is a .bpc section in a link input object file, the linker checks values specified as BPC values. If values do not match between input object files, the linker outputs an error message like the following and suspends link processing.

```
F4457: input files have different BPC value.
0x00001234file1.o
0x00001234file2.o
0x00001235file3.o
*(none)*file4.o
```

In the above case, there is an error because the value set in file3.o is different.

Object that does not reference the programmable peripheral I/O register is not checked. As in file4.o above, "**(none)**" is displayed.

If there are no errors in checking BPC values, a .bpc section is generated with section type SHT_PROGBITS, section attribute none, and section size 0x4. The start address of the programmable peripheral I/O register area, which is the BPC value shifted a preset number of bits, is stored in the .bpc section.

Example

If the BPC value is specified as "0x1234" when using the V850E/IA1, the start address of the programmable peripheral I/O register area is the value shifted 14 bits to the left, or "0x48d0000". In this case, the information in the .bpc section is as follows.

```
.bpc
Address      00 01 02 03 04 05 06 07 - 08 09 0A 0B 0C 0D 0E 0F
0x00000000 : 00 00 8d 04                -                ...
```

- The processing above is performed without question when creating a relocatable object file and when creating an executable object file.
- The .bpc section is a special reserved section for information and is never loaded into memory. Therefore, it need not be specified in a link directive like a normal section.

5.7.12 Option byte

Describe 6-byte data in the assembly language source as follows in order to use the option byte function.

```
.section "OPTION_BYTES"  
.byte0b00000001-- 0x7a  
.byte0b00000000-- 0x7b  
.byte0b00000000-- 0x7c  
.byte0b00000000-- 0x7d  
.byte0b00000000-- 0x7e  
.byte0b00000000-- 0x7f
```

- If a device not having the option byte is specified, it is handled as an ordinary input section.
- If a device having the option byte is specified and if description of this section is omitted, the initial value set in the device file is set.
- Be sure to describe 6 bytes for this section. If less than 6 bytes is described, the following message is output and linking is stopped.

```
F4112: illegal "section" section size.
```

- The initial value of a bit that cannot be set must not be changed. If it is changed, the following message is output.

```
W4613: illegal flash mask option access (file:"file" address:num1 bit:num2)
```

CHAPTER 6 ROMIZATION PROCESSOR

This chapter describes an outline of the ROMization processor (romp850), as well as the ROMization procedure, operation method, etc.

6.1 Flow of Operation

When a variable is declared globally within a program, the variable is allocated to the data-attribute section in RAM if the variable has a default value, or to the bss-attribute section if it does not have a default value. When the variable has a default value, that default value is also stored in RAM. In addition, program code may be stored in the internal RAM area to speed up applications.

In the case of an embedded system, if a debug tool such as an in-circuit emulator is used, executable modules can be downloaded and executed just as they are in the allocation image. However, if the program is actually written to the target system's ROM area before being executed, the default value information that has been allocated to the data-attribute section and the program code that has been allocated to a RAM area must be deployed in RAM prior to execution. In other words, data that is residing in RAM must be deployed in ROM, and this means that data must be copied from ROM to RAM before the corresponding application is executed.

The romp850 (ROMization processor) is a tool that takes default value information for variables in data-attribute sections as well as programs allocated to RAM and packs them into a single section. This section is allocated in ROM and the default value information or program code it contains can be easily deployed in RAM by calling the copy function that is provided by the CA850.

The following figure shows an outline of the operation flow in creating objects for ROMization.

Figure 6 - 1 Creation of Object for ROMization

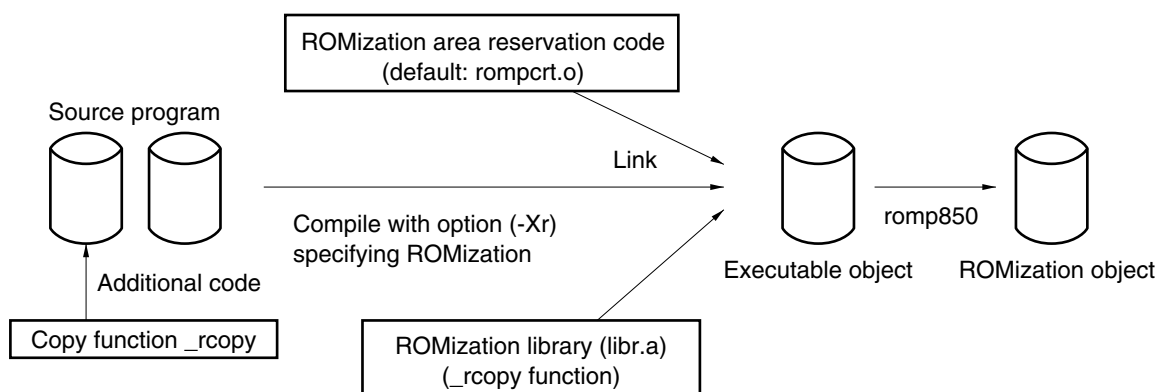

When ROMization objects are created as shown in the figure, execution of the `_rcopy` function copies the data to be allocated to RAM from the packed ROM section. An image of this operation is shown below.

Figure 6 - 2 Image of Processing Immediately After `_rcopy` Function Call

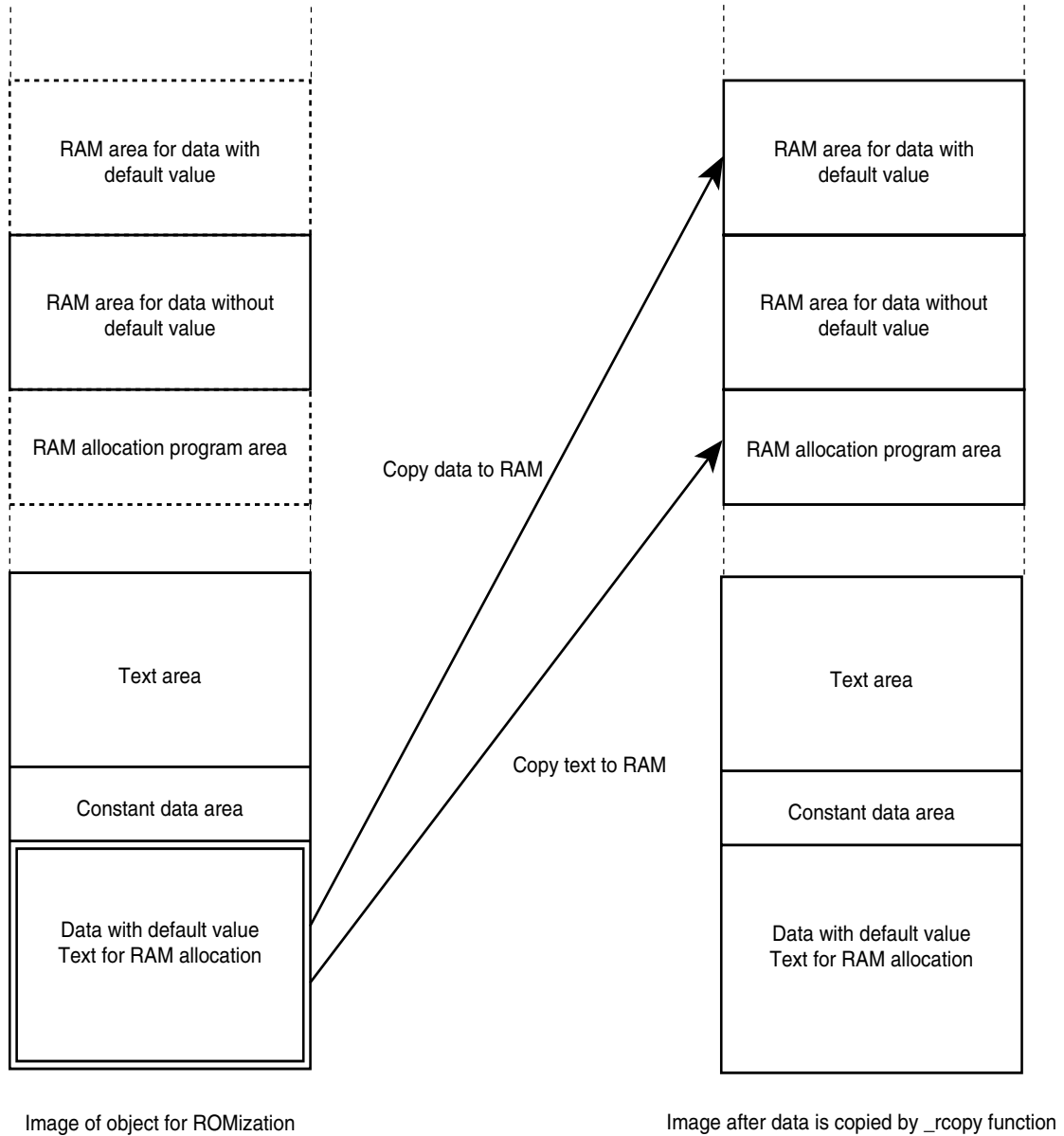

The default values for the section name and the section's start address (label name) required for the ROMization object are as follows.

- Name of packed section — rompsec section
- Start address (label name) of rompsec section — `__S_romp`

The function used to copy from the rompsec section to the RAM area is as follows.

- Copy function — `_rcopy`, `_rcopy1`, `_rcopy2`, `_rcopy4` function

This function is stored in the library "lib.a" which is in the lib850** folder.

`__S_romp` is a label that is defined by "rompct.o" in the lib850** folder (the corresponding source file is rompct.s). The rompct.o object file is used as it is when the romp850 automatically creates a rompsec section immediately after (at the 4-byte alignment position) the .text-attribute section. `__S_romp` becomes the label indicating the start address of that rompsec section.

In addition to this method for automatically creating a rompsec section, it is also possible to independently create and allocate a program corresponding to the rompct.s source file. For details of this method, refer to "[6.4.2 Creating procedure \(customize\)](#)".

During ROMization, once the object for ROMization has been created, it is converted into a hexadecimal file and written to ROM. If the application does not include any data that requires packing, there is no need to create a ROMization object. Instead, the object created by the linker can be converted directly into a hexadecimal file.

If the object files resolved for relocation include symbol information and debug information, romp850 creates a ROMization object file without deleting them.

Therefore, the debugger can debug the source even with a ROMization object file.

6.2 Input/Output Files

The romp850 enables the following files to be handled as input files.

- *file1.out* ... Executable object output by linker

The file that is output is:

- *file2.out* ... Executable object for ROMization

The linker and the romp850 are both able to specify I/O file names. The default output file name is romp.out.

6.3 rompsec Section

6.3.1 Types of sections to be packed

The default setting for the types of data that can be packed in a rompsec section is "data allocated to sections having a write-enabled attribute". In addition, any section that has either the text attribute or const attribute can be specified for packing by specifying the -t option.

Specific examples of packing targets are listed below.

- (1) The reserved sections listed in Table 7-1
- (2) Any section created with any name, as long as either the sdata attribute or data attribute has been specified for it by the .section quasi directive in an assembly language program

Table 6 - 1 Reserved Sections Packed by romp850

.data,	.sdata,	.sedata,	.sidata,
.tidata,	.tidata.byte,	.tidata.word	

Note, however, that if any user-specified sections with either the text attribute or const attribute are not packed and if the above-listed sections are not in an executable module, there is no need to create a ROMization object. See the link map file to determine whether or not the sections listed in Table 7-1 exist in an executable module.

In addition, the object file created by the romp850 can be referenced via the dump command (dump850) to confirm that a rompsec section has been created in place of another section such as a .data section or .sdata section.

6.3.2 Size of rompsec section

This section describes the memory area size to be reserved for the rompsec section.

When creating the ROMization module, note the size of the rompsec section as well as the internal ROM capacity of the target CPU and the address range and size of the target system's ROM area. Code the link directive file carefully to prevent the rompsec section from overlapping other sections. For specific code examples, refer to "[6.4 Creating Object for ROMization](#)".

Formulas used to calculate the size of the rompsec section are shown below.

$$8 + 16 \times (\text{Number of sdata/data sections}) + \text{Size of sdata/data section} \\ + \text{Padding size}^{\text{Note}}$$

For example, if .sdata and .data sections exist, the size of each is 1002 bytes and 1000 bytes, and the alignment condition of each section is 4 bytes, the size of the rompsec section is as follows.

$$8 + 16 \times 2 + 1002 + 1000 + 2 = 2044 \text{ bytes}$$

Note The padding size is 0 to 3 bytes per section, depending on the alignment condition of the section subject to ROMization.

6.3.3 rompsec section and link directive

During ROMization, a rompsec section is added immediately after the .text section. By allocating the .text section to the end of ROM, therefore, the rompsec section up to the end of ROM can be allocated.

Figure 6 - 3 Link Directive Taking ROMization Processing into Consideration

```
# Allocates SCONST, CONST, and TEXT to internal ROM
SCONST : !LOAD ?R {
    .sconst = $PROGBITS ?A .sconst;
};

CONST : !LOAD ?R {
    .const = $PROGBITS ?A .const;
};

# Allocates .text to end of internal ROM
TEXT : !LOAD ?RX {
    .pro_epi_runtime = $PROGBITS ?AX .pro_epi_runtime;
    .text = $PROGBITS ?AX .text;
};

# Allocates DATA to external RAM
DATA : !LOAD ?RX V0x100000 {
    .data = $PROGBITS ?AW;
    .sdata = $PROGBITS ?AWG;
    .sbss = $NOBIT ?AWG;
    .bss = $NOBIT ?AW;
};

# Allocates SIDATA to internal RAM
SIDATA : !LOAD ?RX V0xffe000 {
    .sidata = $PROGBITS ?AW .sidata;
    .sibss = $NOBIT ?AWG .sibss;
};

__tp_TEXT @ %TP_SYMBOL;
__gp_DATA @ %GP_SYMBOL & __tp_TEXT{DATA};
__ep_DATA @ %EP_SYMBOL;
```

If the rompsec section exceeds the internal ROM area, the following message is output and the processing is stopped.

```
F8425 : rompsec section overflowed highest address of target machine.
```

By specifying the `-rom_less` option, the internal ROM area may be ignored.

By specifying the `-Ximem_overflow=warning` option, an error message can be changed to a warning message.

The above check is not performed if the rompsec section is allocated to the end of the external ROM area.

Check the memory map information to see if the sections fit in ROM.

If it is necessary to allocate the rompsec section in the middle of ROM, check the area where the rompsec sec-

tion is to be allocated as follows, from the size and allocation address of the rompsec section, and specify an appropriate address for the segment immediately after the rompsec section.

Figure 6 - 4 Link Directive Taking ROMization Processing into Consideration (Size Considered)

```
# Allocates SCONST, CONST, and TEXT to internal ROM
SCONST : !LOAD ?R {
    .sconst = $PROGBITS ?A .sconst;
};

# Allocates .text in middle of internal ROM
TEXT : !LOAD ?RX {
    .pro_epi_runtime = $PROGBITS ?AX .pro_epi_runtime;
    .text = $PROGBITS ?AX .text;
};
#
# rompsec between TEXT and CONST
#
# Allocates CONST to end of internal ROM by specifying address
# taking size into consideration
CONST : !LOAD ?R Vx3f800 {
    .const = $PROGBITS ?A .const;
};

# Allocates DATA to external RAM
DATA : !LOAD ?RX V0x100000 {
    .data = $PROGBITS ?AW;
    .sdata = $PROGBITS ?AWG;
    .sbss = $NOBIT ?AWG;
    .bss = $NOBIT ?AW;
};

# Allocates SIDATA to internal RAM
SIDATA : !LOAD ?RX V0xffe000 {
    .sidata = $PROGBITS ?AW .sidata;
    .sibss = $NOBIT ?AWG .sibss;
};

__tp_TEXT @ %TP_SYMBOL;
__gp_DATA @ %GP_SYMBOL &__tp_TEXT{DATA};
__ep_DATA @ %EP_SYMBOL;
```

6.4 Creating Object for ROMization

6.4.1 Creating procedure (default)

This section describes a method that uses the ROMization area reservation code (rompctr.o) that is provided as the default object.

- (1) First, a copy function is called within the application.

The copy function should be activated early on, such as within the startup routine or at the start of the main function. `_rcopy`, `_rcopy1`, `_rcopy2`, and `_rcopy4` are available as copy functions, and each of these has a different transfer size (the transfer size of `_rcopy` and `_rcopy1` is the same). For details of the copy functions, refer to "6.5 Copy Functions". An example of using a copy function is shown in the figure below.

In this example, the `_rcopy` function is activated at the start of the main function.

Figure 6 - 5 Example of Using Copy Function `_rcopy 1`

```
#define ALL_COPY(-1)

int _rcopy(unsigned long *, long);
extern unsigned long _S_romp;

void main(void)
{
    intret;

    ret = _rcopy(&_S_romp, ALL_COPY);

    :
}
```

- (2) During ROMization, the rompsec section is added immediately after the `.text` section.

By allocating the `.text` section to the end of ROM, the rompsec section up to the end of ROM can be allocated (refer to [Figure 6 - 3](#)).

- (3) Specify "Create Object for ROM" as a compiler option.

- From command line:

Add compiler option "-Xr".

- From PM+:

Check "Create Object for ROM" on the [ROM] tab of the [Compiler Common Options] dialog box.

As a result, a code that indicates that label `__S_romp` indicates the first address that exceeds the end of the `.text` section in the object is generated.

(4) Compile and link.

By specifying "Create Object for ROM" for the ca850, the ROMization area reservation code "rompcrt.o" (that is in lib850r**) and "libr.a" that stores the _rcopy function are automatically linked. At this time, the linking sequence is relevant. Because "rompcrt.o" must be linked at the end of a group of TEXT attributes, link it after the libraries specified by the -l option for linking if the linker has been activated from the command line. If PM+ is used, there is no need to be aware of "rompcrt.o" because it is automatically linked at the end of the TEXT attribute group.

(5) Activate the ROMization processor (romp850).

Generate a ROMization module from the executable module completed in (4), by using the romp850. If "Create Object for ROM" is specified with PM+, (4) and this is automatically performed, and a hex file is generated. If the compiler package has been activated from the command line, the romp850 is activated and a ROMization object is created after the ca850 to ld850 have been activated and an executable module has been generated. An image of the map is shown below.

Figure 6 - 6 ROMization Image 1

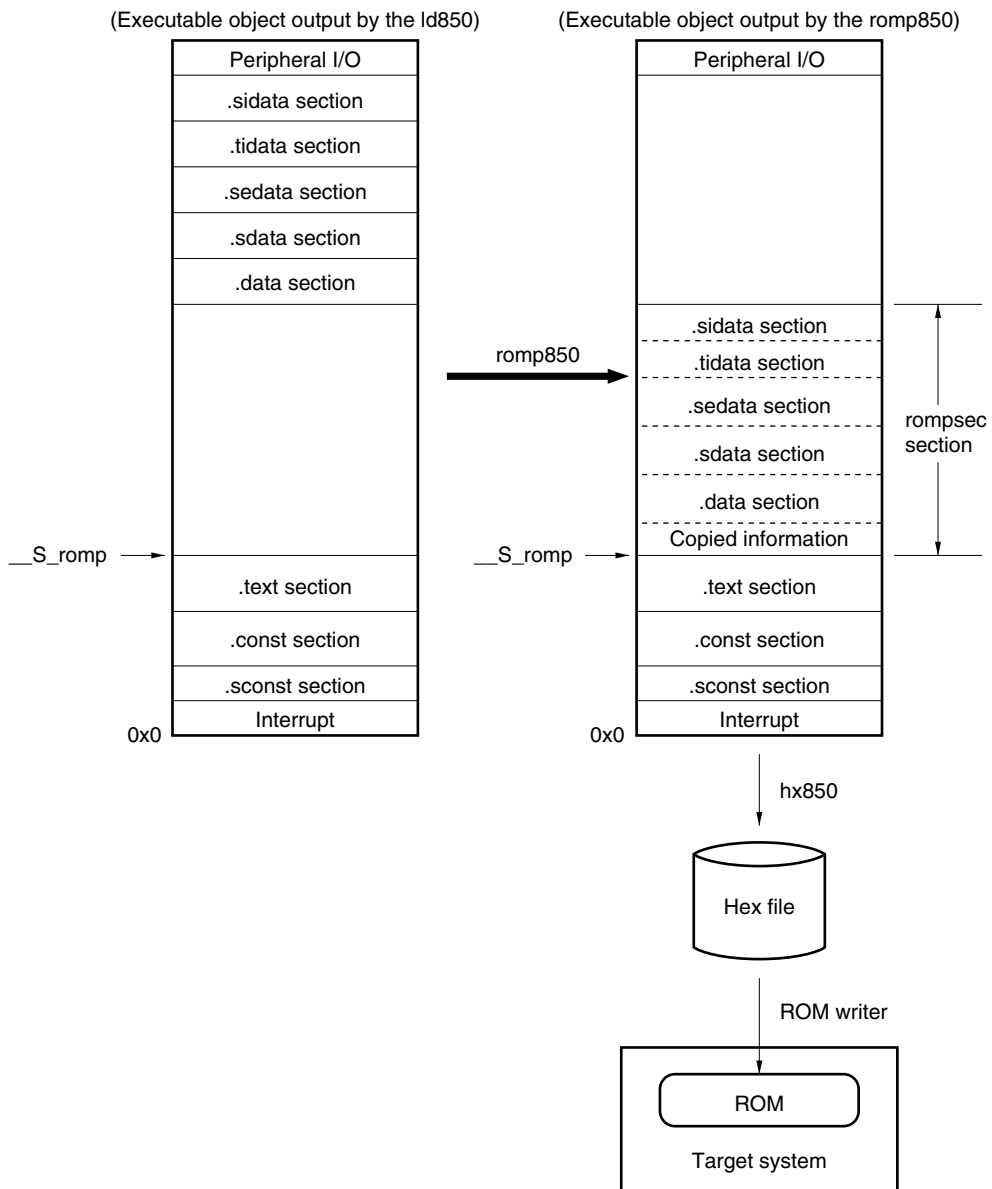

6.4.2 Creating procedure (customize)

This section describes the method for independently creating the rompctr.o program corresponding to the ROMization area reservation code and determining the desired rompctr section start address and allocation position.

- (1) Enter code corresponding to the default "rompctr.s" ROMization area reservation code.

Let us assume the specified file name is "rompack.s" and the name of the symbol specifying the start of the ROMization area is "__rompack". Also, the section containing this symbol is the "rompack section". In this case, the code in rompack.s appears as follows.

Figure 6 - 7 Example of rompack.s

```
.file"rompack.s"
.section".rompack",text
.align4
.globl__rompack, 4
__rompack:
```

- (2) A copy function is called within the application.

The copy function should be activated early on, such as within the startup routine or at the start of the main function. `_rcopy`, `_rcopy1`, `_rcopy2`, and `_rcopy4` are available as copy functions, and each of these has a different transfer size (the transfer size of `_rcopy` and `_rcopy1` is the same). For details of the copy functions, refer to "6.5 Copy Functions". An example of using a copy function is shown in the figure below.

In this example, the `_rcopy` function is activated at the start of the main function.

Figure 6 - 8 Example of Using Copy Function `_rcopy 2`

```
#define ALL_COPY (-1)

int _rcopy(unsigned long *, long);
extern unsigned long _rompack;

void main(void)
{
    intret;

    ret = _rcopy(&_rompack, ALL_COPY);
    :
}
```

- (3) Define the created rompack section in a link directive.

At the same time, you can specify the rompack section's allocation site as any address. For example, to specify ROMPACK as the segment containing the rompack section and to allocate that segment to start at address 0x3000, enter the following link directive.

Figure 6 - 9 Link Directive Specification Example

```
TEXT: !LOAD ?RX V0x1000 {
    .text = $PROGBITS ?AX .text;
};

ROMPACK: !LOAD ?RX V0x3000 {
    .rompack = $PROGBITS ?AX .rompack;
};

:
```

The rompack section's size is estimated using the formula described in "6.3.2 Size of rompssec section" to avoid the ROMPACK segment's allocation address from overlapping with adjacent segments. This information is reflected in the link directive file.

- (4) Specify "Create Object for ROM" as a compiler option.

- From command line:

Add compiler option "-Xr".

- From PM+:

Check "Create Object for ROM" on the [ROM] tab of the [Compiler Common Options] dialog box.

This generates code that specifies the same address for label "rompack" as is specified for rompssec.

- (5) Specify the compiler common option and ROMization processor option.

- From command line:

As a ROMization processor option, specify "__rompack" for the "-b" option to specify the entry symbol for the ROMization area reservation code.

- From PM+:

Add "rompack.s" or "rompack.o" to "rompct file" on [ROM] tab of the [Compiler Common Options] dialog box.

Describe "__rompack" which is the first label of the rompack section into "Entry Label[-b]" on the [Option] tab of the [ROM Processor Options] dialog box.

- (6) Compile and link.

When the compiler is instructed to create an object for ROMization, the library "libr.a", which contains the _rcopy function, is automatically linked.

(7) Activate the ROMization processor (romp850).

Use the romp850 to create a ROMization module from the executable module completed at step (6). If "Create Object for ROM" has been specified via PM+, the processing from steps (6) to this step is performed automatically up to the creation of the hexadecimal file. If activation was via the command line, after the ld850 has been activated from the ca850 and the executable module has been created, the romp850 is activated to create the object for ROMization.

A corresponding mapping image is shown below.

Figure 6 - 10 ROMization Image 2

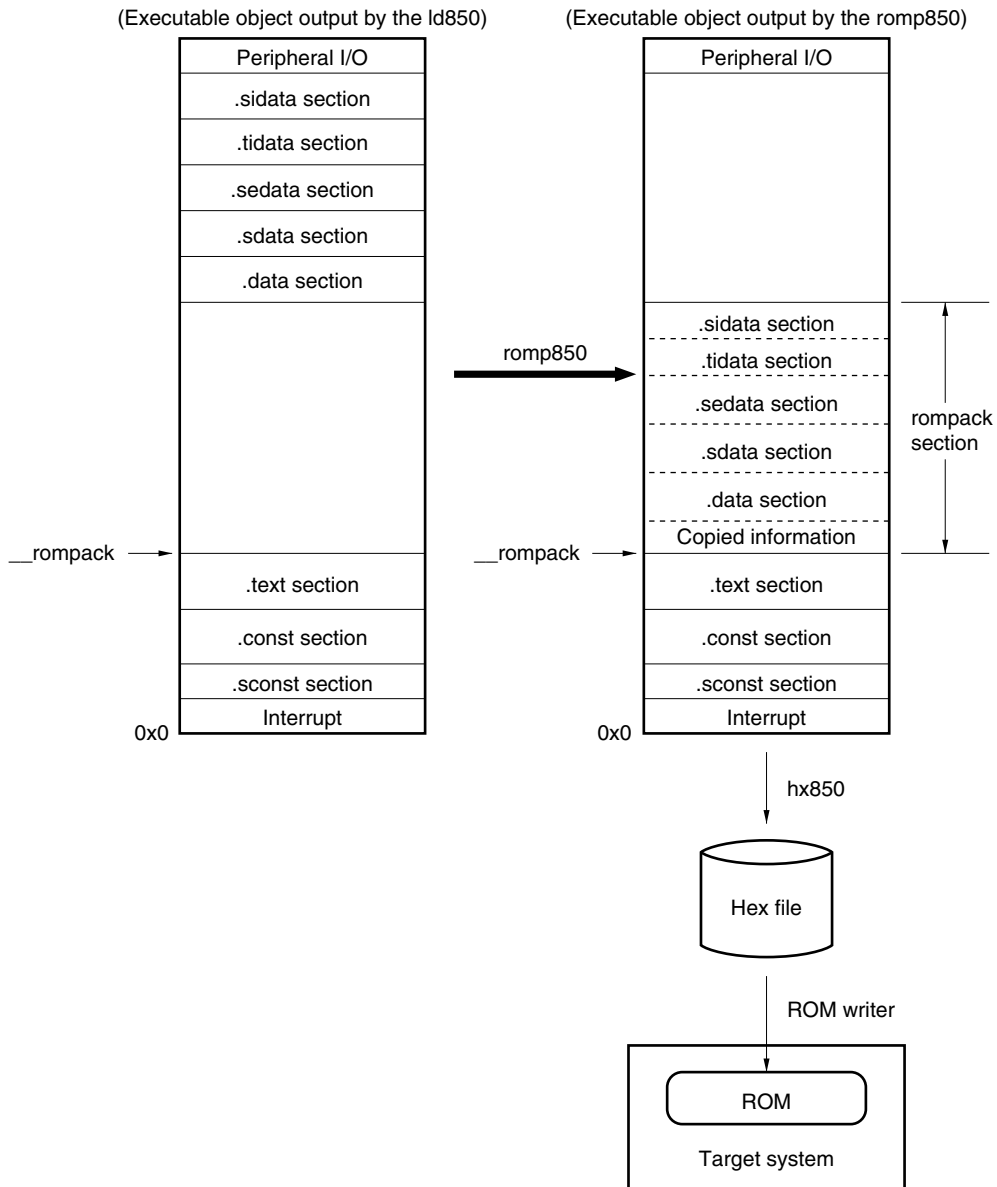

6.5 Copy Functions

6.5.1 Copy routine

This section describes the copy routines (`_rcopy`) necessary for the program to be stored in ROM.

Table 6 - 2 Copy Routines

Function Name	Feature
<code>_rcopy</code>	Copies ROMization section (1-byte transfer)
<code>_rcopy1</code>	Copies ROMization section (1-byte transfer)
<code>_rcopy2</code>	Copies ROMization section (2-byte transfer)
<code>_rcopy4</code>	Copies ROMization section (4-byte transfer)

Use 1-byte, 2-byte, or 4-byte transfer, depending on the specification of the RAM at the transfer destination. The specification of each function is as follows.

_rcopy

[Overview]

`_rcopy`

Copies default data or RAM text^{Note} (1 byte).

Note Data section with initial value which is to be allocated to RAM, and text section for internal RAM.

[Format]

```
int      _rcopy(&label, number)
unsigned long label;
long     number;
```

[Description]

`_rcopy(&label, number)` copies the initial value data of section number `number` to be copied, or text to be allocated to RAM, to the RAM area 1 byte at a time, based on the information in the `rompsec` section allocated starting at the address following the address indicated by `label`. If `-1` is specified as `number`, all sections in the `rompsec` section are copied. Section number `number` is a positive number that starts from 1.

By default, sections are allocated in the order in which they appear in the input file. If sections to be allocated to the `rompsec` section are specified by the `"-p"` or `"-t"` option of the `romp850`, they are allocated in the order in which they are specified. If a ROM section file is created with `PM+`, however, a C language source header file that makes `"number"` and `"label"` correspond to each other by `#define` is generated, and `number` can be specified by a label name.

For a specific example, refer to "[6.5.2 Example](#)".

[Return value]

0	Normal completion (if copied correctly)
-1	Abnormal termination (if not copied correctly)

[Cautions]

- Data is not copied if the address indicated by `label` is not at the start of the `rompsec` section.
- `_rcopy` copies data in accordance with the information generated by the `romp850`.
- No data is copied if data may be overwritten as a result of copying.
- Specify a global label having an absolute value or an absolute address as the first argument of `_rcopy`, `label`. If any other value or address is specified, the result is not guaranteed.
- The `_rcopy` and `_rcopy1` functions are identical in feature. `_rcopy` is used to maintain compatibility with old versions.

_rcopy1

[Overview]

`_rcopy1`

Copies default data or RAM text^{Note} (1 byte).

Note Data section with initial value which is to be allocated to RAM, and text section for internal RAM.

[Format]

```
int      _rcopy1(&label, number)
unsigned long label;
long     number;
```

[Description]

`_rcopy1(&label, number)` copies the initial value data of section number `number` to be copied, or text to be allocated to RAM, to the RAM area 1 byte at a time, based on the information in the `rompsec` section allocated starting at the address following the address indicated by `label`. If `-1` is specified as `number`, all sections in the `rompsec` section are copied. Section number `number` is a positive number that starts from 1.

By default, sections are allocated in the order in which they appear in the input file. If sections to be allocated to the `rompsec` section are specified by the `"-p"` or `"-t"` option of the `romp850`, they are allocated in the order in which they are specified. If a ROM section file is created with `PM+`, however, a C language source header file that makes `"number"` and `"label"` correspond to each other by `#define` is generated, and `number` can be specified by a label name.

For a specific example, refer to "[6.5.2 Example](#)".

[Return value]

0	Normal completion (if copied correctly)
-1	Abnormal termination (if not copied correctly)

[Cautions]

- Data is not copied if the address indicated by `label` is not at the start of the `rompsec` section.
- `_rcopy1` copies data in accordance with the information generated by the `romp850`.
- No data is copied if data may be overwritten as a result of copying.
- Specify a global label having an absolute value or an absolute address as the first argument of `_rcopy1`, `label`. If any other value or address is specified, the result is not guaranteed.
- The `_rcopy1` and `_rcopy` functions are identical in feature. `_rcopy` is used to maintain compatibility with old versions.

_rcopy2

[Overview]

`_rcopy2`

Copies default data or RAM text^{Note} (2 byte).

Note Data section with initial value which is to be allocated to RAM, and text section for internal RAM.

[Format]

```
int      _rcopy2(&label, number)
unsigned long label;
long    number;
```

[Description]

`_rcopy2(&label, number)` copies the initial value data of section number `number` to be copied, or text to be allocated to RAM, to the RAM area 2 bytes at a time, based on the information in the `rompsec` section allocated starting at the address following the address indicated by `label`. If `-1` is specified as `number`, all sections in the `rompsec` section are copied. Section number `number` is a positive number that starts from 1.

By default, sections are allocated in the order in which they appear in the input file. If sections to be allocated to the `rompsec` section are specified by the `"-p"` or `"-t"` option of the `romp850`, they are allocated in the order in which they are specified. If a ROM section file is created with `PM+`, however, a C language source header file that makes `"number"` and `"label"` correspond to each other by `#define` is generated, and `number` can be specified by a label name.

For a specific example, refer to "[6.5.2 Example](#)".

[Return value]

0	Normal completion (if copied correctly)
-1	Abnormal termination (if not copied correctly)

[Cautions]

- Data is not copied if the address indicated by `label` is not at the start of the `rompsec` section.
- `_rcopy2` copies data in accordance with the information generated by the `romp850`.
- No data is copied if data may be overwritten as a result of copying.
- Specify a global label having an absolute value or an absolute address as the first argument of `_rcopy2`, `label`. If any other value or address is specified, the result is not guaranteed.

_rcopy4

[Overview]

`_rcopy4`

Copies default data or RAM text^{Note} (4 byte).

Note Data section with initial value which is to be allocated to RAM, and text section for internal RAM.

[Format]

```
int      _rcopy4(&label, number)
unsigned long label;
long     number;
```

[Description]

`_rcopy4(&label, number)` copies the initial value data of section number `number` to be copied, or text to be allocated to RAM, to the RAM area 4 bytes at a time, based on the information in the `rompsec` section allocated starting at the address following the address indicated by `label`. If `-1` is specified as `number`, all sections in the `rompsec` section are copied. Section number `number` is a positive number that starts from 1.

By default, sections are allocated in the order in which they appear in the input file. If sections to be allocated to the `rompsec` section are specified by the `"-p"` or `"-t"` option of the `romp850`, they are allocated in the order in which they are specified. If a ROM section file is created with `PM+`, however, a C language source header file that makes `"number"` and `"label"` correspond to each other by `#define` is generated, and `number` can be specified by a label name.

For a specific example, refer to "[6.5.2 Example](#)".

[Return value]

0	Normal completion (if copied correctly)
-1	Abnormal termination (if not copied correctly)

[Cautions]

- Data is not copied if the address indicated by `label` is not at the start of the `rompsec` section.
- `_rcopy4` copies data in accordance with the information generated by the `romp850`.
- No data is copied if data may be overwritten as a result of copying.
- Specify a global label having an absolute value or an absolute address as the first argument of `_rcopy4`, `label`. If any other value or address is specified, the result is not guaranteed.

6.5.2 Example

(1) To transfer all sections in 1-byte units

```
extern unsigned long _S_romp;

main()
{
    intret;
    ret = _rcopy(&_S_romp, -1);
    /* -Xr specifies a global label having an absolute value. */
}
```

The label references an absolute address when the ca850's ROMization option has been specified as shown above. Therefore, describe as follows to call `_copy()` in an assembly language source program.

```
.extern __S_romp, 4-- Declared as an external label

# Calls rcopy with absolute address of __S_romp as first argument
# and -1 as second argument
    mov#__S_romp, r6
    mov-1, r7
    jarl__rcopy, lp
```

(2) To transfer sections 1 to 6 in 4-byte units and sections 7 to 11 in 1-byte units

```
extern unsigned long _S_romp;

main()
{
    intret, num;

    for(num=1; num<=6; num++) {
        ret=_rcopy4(&_S_romp, num);
        if(ret==-1) {
            /* Error processing */
        }
    }

    for(num=7; num<=11; num++) {
        ret=_rcopy1(&_S_romp, num);
        if(ret==-1) {
            /* Error processing */
        }
    }
}
```

(3) Example of incorrect specification 1

```
extern unsigned long _S_romp;
char *cp;

void func(void)
{
    intret;

    /* First argument is gp relative value because copied to variable */
    cp = &_amp;_S_romp;
    ret = _rcopy(cp, -1);
}
```

(4) Example of incorrect specification 2

```
extern unsigned long _S_romp;
int i;

void func(void)
{
    intret;

    /* First argument is gp relative value because copied to variable */
    i = 0x100;
    ret = _rcopy(i, -1);
}
```

- The section number to be specified as number should be a positive number that starts from 1. The relationship between the section name and section number can be referenced from the memory map. When PM+ is used, a C language header file in which correspondence between the section number and label is established can be created by outputting a ROM section file. In other words, a label can be used as number. For the method of outputting the ROM section file and for the label naming rules, refer to "[6.8.1 \[ROM Processor Options\] dialog box](#)".
- If a section number or -1 is not specified as number, nothing is copied.
- If two or more RAMs exist and two or more copy routines are used, and if -1 is specified as number, data cannot be correctly copied due to problems such as alignment of all sections. In this case, do not specify -1 as number; specify a section number.
- If -1 is specified as number, data is copied in the order of section numbers. If there is a section that is not copied, -1 is returned as the return value. Sections following the section in which a problem has occurred are not copied.

6.6 Operation Method

This section describes how to operate the romp850 (ROMization processor).

6.6.1 Command input method

Enter the following from the command prompt.

```
romp850 [option] ... file nam
[ ]: Can be omitted
...: Pattern in preceding [ ] can be repeated
```

6.6.2 Method using PM+

The [\[ROM Processor Options\] dialog box](#) that is used to set ROMization processor options can be displayed via the following method once a project has been established under PM+.

- Select [Tool] - [ROM Processor Options...]

Since the ROMization processor is activated once per project, there are no file-specific settings.

The name of the executable object file that is output by the ROMization processor is the name of the first file shown in the "Source file name" list when the [Source file] tab is selected via the [Project Settings] dialog box in the PM+. The extension ".out" is added to this file name, which makes it identical to the object file output by the linker.

The default file name is romp.out. To modify the name of the object file, specify a file name in "[Output File\[-o\]](#)" field on the [\[File\]](#) tab.

Note that the ROMization processor can be started from PM+ only when the "[Create Object for ROM](#)" has been specified on the [\[ROM\]](#) tab in the [\[Compiler Common Options\] dialog box](#).

6.7 Types and Features of Options

The romp850 options are shown below.

[Symbols used in option list]

[PM+]	Option exists as specification item under the PM+.
--------------	--

6.7.1 File

This specification sets the file's output file options.

+err_file=file

This option adds and saves error messages to the file *file*.

-err_file=file

This option overwrites and saves error messages to the file *file*.

-o ofile

[PM+]

The *ofile* is the object file name to be created.

If this option is omitted, it is assumed that "romp.out" has been specified. "a.out" cannot be specified as the file name. Spaces cannot be used in the file name.

6.7.2 Options

These specifications set the ROMization processor's ordinary options.

-Ximem_overflow=warning

[PM+]

This option controls checking if the internal ROM/RAM has overflowed. A warning message is output and processing is continued in case of an overflow.

If this option is omitted, an error message is output and processing is stopped if an overflow occurs.

-b *label*

[PM+]

The label *label* indicates the start address of the rompssec section to be created. If the specified label does not exist in the object file or if the option has been specified more than once, a message is output and processing is stopped.

If this option is omitted, it is assumed that `__S_romp` has been specified.

-d

[PM+]

This option creates an object file that includes only a rompssec section; no text-attribute section is inserted in the file to be created.

If this option is omitted, a section with the text attribute is inserted.

-i

[PM+]

This option prevents checking of duplicate addresses in input files and output files.

-m [=mapfile]

[PM+]

This option outputs to *mapfile* a memory map of the object file to be created.

If *mapfile* is omitted, the link map is output to the standard output.

-p *section*

[PM+]

This option inserts the contents of the section name *section* and the corresponding address and size information into the rompssec section. If the specified *section* does not exist in the object file, a message is output and processing is stopped. This option is applicable for data-attribute and sdata-attribute sections. If this option is specified more than once, insertion to the rompssec section occurs according to the order of specification. If this option is omitted, it is assumed that all sections having the data attribute or sdata attribute have been specified. Spaces cannot be used in the section name.

-rom_less**[PM+]**

This option does not check the rompsec section for a peripheral location error of the internal ROM. It is recommended to specify this option in the ROMless mode.

This option does not support checking of overflow of the internal ROM in the single-chip mode. Specify this option to invalidate overflow check of the internal ROM and check for overflow with the dump850.

If this option is omitted, the rompsec section is checked for a peripheral location error of the internal ROM.

-t *section***[PM+]**

This option inserts the contents of the section name *section* and the corresponding address and size information into the rompsec section. If the specified section does not exist in the object file, a message is output and processing is stopped. This option is applicable for text-attribute and const-attribute sections. If this option is specified more than once, insertion to the rompsec section occurs according to the order of specification. Only sections having either a text attribute or the const attribute can be specified by this option. If any other type of section is specified, a message is output and processing is stopped. Spaces cannot be used in the section name.

6.7.3 Other

The specifications set other options.

-F *devpath*

This option sets the device file search to begin in the *devpath* folder. If this option is omitted, the search goes directly to the standard folders.

-v

This option outputs the ROMization processor's version information as standard error output, then terminates.

-help

This option outputs a help description of ROMization processor options as standard error output.

@*cfile*

This option handles *cfile* as a command file. A command file specifies an option and a file name for a command not as arguments on the command line but by describing them in a file. On Windows, the length of a character string specified as an option of a command is limited. If many options are set and some of the options cannot be recognized, create a command file and specify this option.

For details of the command file, refer to "[3.7.2 Command file](#)".

6.8 Settings Made via PM+

This section describes dialog boxes that are used to set the command options of the romp850 for the target project's source file.

6.8.1 [ROM Processor Options] dialog box

At the upper part of this dialog box, the following four tabs are displayed.

The contents of this dialog box depend on selecting the following tab.

Table 6 - 3 [ROM Processor Options] Dialog Box

Tab	Description
[File]	Setting of options related to files
[Section]	Setting of sections to be ROMized
[Option]	Setting of romp850 options
[Others]	Other settings

Note The option shown with "[]" in this dialog box is the option that is activated from the command line.

[File]

This tab is used to set options related to files of the romp850.

Figure 6 - 11 [ROM Processor Options] Dialog Box ([File] Tab)

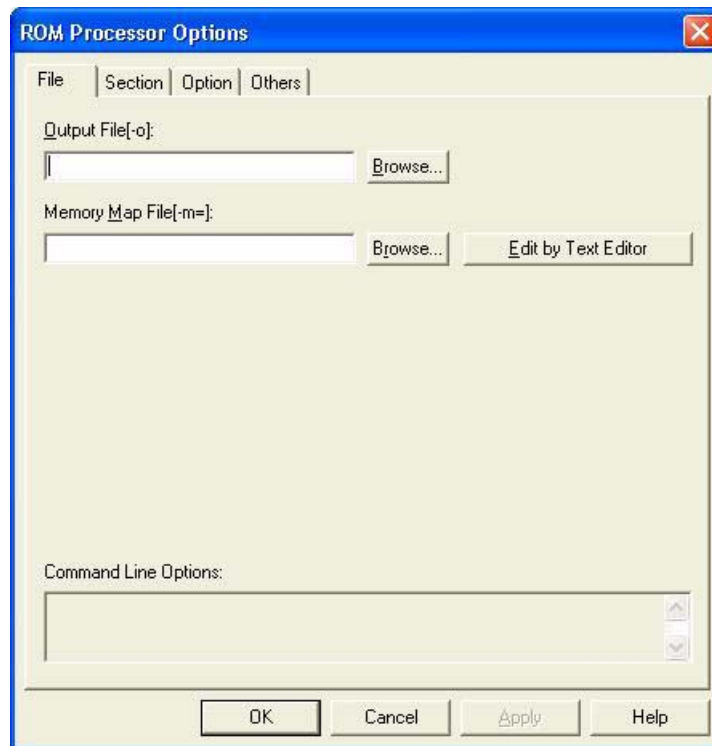

(1) Output File[-o]

This edit box is used to specify an output file name. Blanks must not be specified as the file name. If no file name is specified, romp.out is assumed as the output file name. Selecting the [Browse...] button opens a dialog box in which a file can be selected.

(2) Memory Map File[-m=]

This edit box is used to specify the name of a file to which mapping information resulting from activating the romp850 is to be output. Selecting the [Edit by Text Editor] button opens the specified file (the file can then be edited).

(3) Command Line Options

This area displays the options set in this dialog box by command line options.

This area is for reference and cannot be written to.

[Section]

This tab is used to set sections to be ROMized.

Figure 6 - 12 [ROM Processor Options] Dialog Box ([Section] Tab)

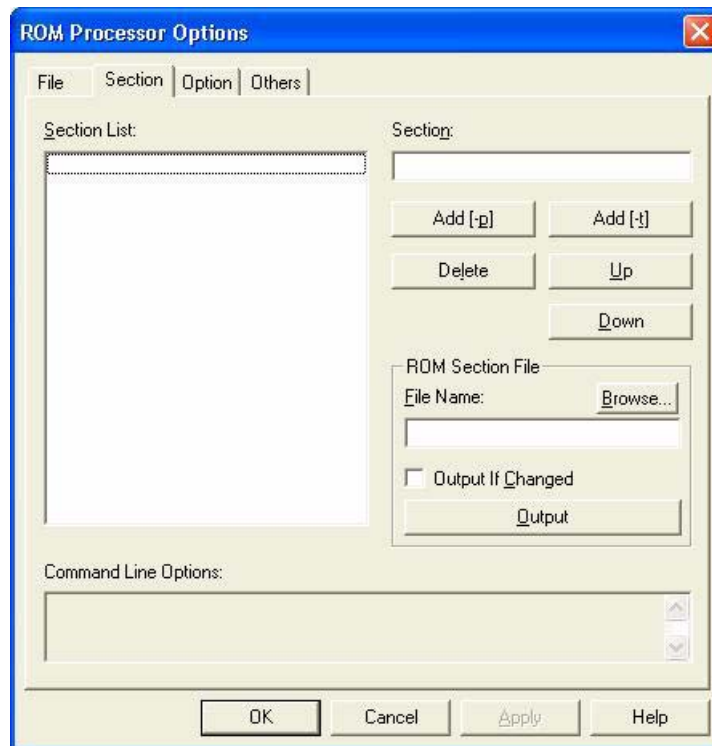

(1) Section List

This list box displays the sections to be ROMized and options in the order in which they were specified.

The sections and options displayed in this list box are stored in the .rompsec section in that order. In other words, the order of the sections and options is equivalent to the number specified by the second argument of `_rcopy`, `_rcopy1`, `_rcopy2`, or `_rcopy4` (numbers are sequentially assigned to sections starting from 1).

If "ROM Section File" to be explained in (3) below is selected, a C language source header file in which "number" and "label" are made to correspond by #define is created, and the number to be specified by the second argument can be specified

(2) Section

To add a section to the list in this dialog box, describe a section name in this text box and then click the [\[Add\[-p\]\]](#) or [\[Add\[-t\]\]](#) button

(a) Add[-p]

This button adds a section to "Section List" as a -p option. It adds the section specified in "Section" to "Section List" as a section to be specified by the -p option. In other words, if the section specified in "Section" has a data or sdata attribute, it is added to the section list by using this button.

(b) Add[-t]

This button adds a section to "Section List" as a -t option. It adds the section specified in "Section" to "Section List" as a section to be specified by the -t option. In other words, if a section specified in "Section" has a text or const attribute, it is added to the section list by using this button.

(c) Delete

This button deletes the section currently selected in "Section List".

(d) Up

This button moves the section currently selected in "Section List" up by one position.

(e) Down

This button moves the section currently selected in "Section List" down by one position.

(3) ROM Section File

A ROM section file makes it easy to specify the number specified by the second argument of `_rcopy`, `_rcopy1`, `_rcopy2`, or `_rcopy4` in an application, and is a C language source header file in which "number" and "label" are made to correspond by `#define`. Therefore the section to be copied from the rompsec section can be specified by specifying a label as the second argument. For example, the following is output if `.text`, `.data`, `.const`, and `text1` are registered to the section list, and the ROM section file is output.

```
#define ROMPSCN__text 1
#define ROMPSCN__data 2
#define ROMPSCN__const 3
#define ROMPSCN_text1 4
```

(a) File Name

If a file name is specified in this text box, the file is output according to (b) or (c).

(b) Output If Change

If this check box is checked, the file specified in the above text box is output when the section is changed and the [OK] or [Apply] button is clicked.

(c) Output

The file is output when the [Output] button is clicked. When the file has been output, a message box is displayed regardless of whether outputting has been successful or has failed.

As many of the following `#define` directives as the number of sections are output in the ROM section file.

```
#define ROMPSCN_<section name> <section number>
```

All the characters that cannot be used as an identifier of the preprocessor are replaced by "_". If the same identifier exists, a message box is displayed and the file cannot be output.

(4) Command Line Options

This area displays the options set in this dialog box by command line options.

This area is for reference and cannot be written to.

[Option]

This tab is used to set romp850 options.

Figure 6 - 13 [ROM Processor Options] Dialog Box ([Option] Tab)

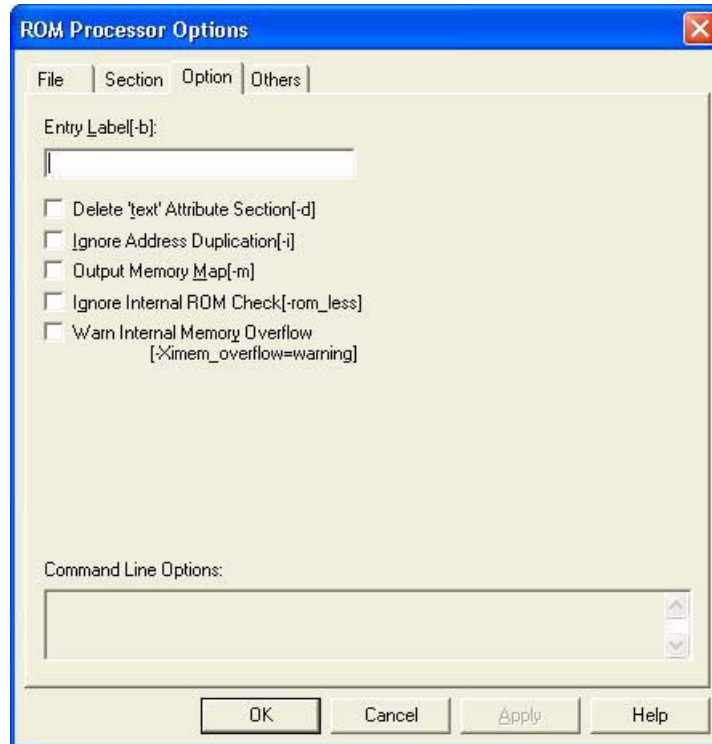

(1) Entry Label[-b]

This option sets the specified label value as the start address of the rompsec section to be created. If the specified label does not exist in the object file, a message is output and processing is stopped. If this option is omitted, it is assumed that `__S_romp` has been specified.

(2) Delete 'text' Attribute Section[-d]

This option creates an object file that contains only the rompsec section and does not include any sections with the text attribute.

(3) Ignore Address Duplication[-i]

This option prevents checking for duplicate addresses among input files and output files.

(4) Output Memory Map[-m]

This option outputs a memory map of the object file created by the romp850 to the PM+'s output window.

The memory map is included in the log files (project name + .plg) automatically generated in the project folder.

(5) Ignore Internal ROM Check[-rom_less]

When this option is selected, the romsec section is not checked for allocation errors of the internal ROM area. It is recommended to specify this option in the ROMless mode. This option does not support checking of overflow of the internal ROM in the single-chip mode. Specify this option to invalidate overflow check of the internal ROM and check the overflow with the dump850. If this option is not specified, the romsec section is checked for allocation errors of the internal ROM area.

(6) Warn Internal Memory Overflow[-Ximem_overflow=warning]

This option sets a message warning of the overflow of the internal memory. If it is selected, a warning message is output. If it is not selected, an error message is output.

(7) Command Line Options

This area displays the options set in this dialog box by command line options.

This area is for reference and cannot be written to.

[Others]

This tab is used to set other options of the romp850.

Figure 6 - 14 [ROM Processor Options] Dialog Box ([Others] Tab)

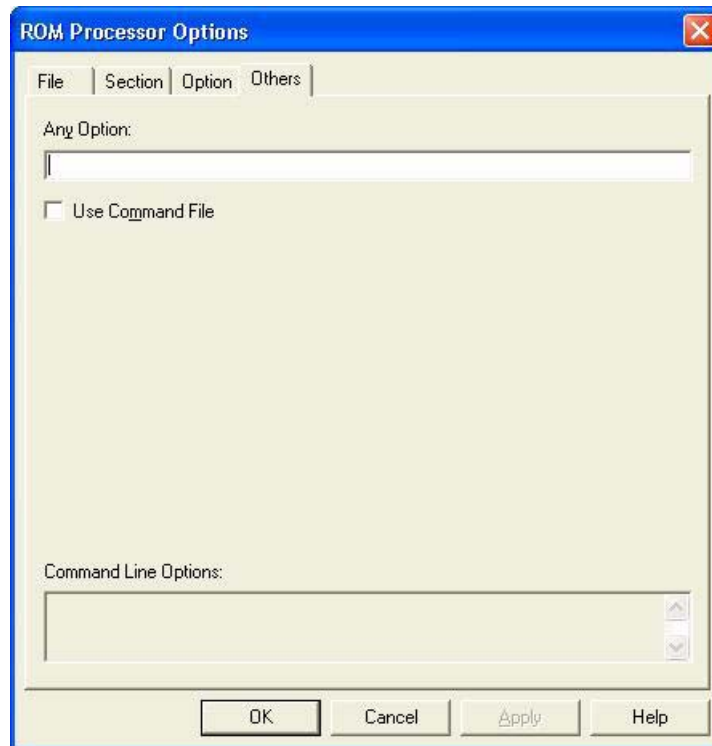

(1) Any Option

This edit box is used to specify an option other than described above on the [ROM Processor Options] dialog box. Describe an option in this edit box in the same format as on the command line.

At present, however, no option has to be specified in this edit box because all the options related to the ROMization processor can be specified in the [ROM Processor Options] dialog box.

(2) Use Command File

In the Windows environment, the length of character strings used to specify options for the ca850 is restricted. If this check box is selected, the option character string is output to a command file, which enables the operation to be completed without observing the restriction on the character string length. Check this check box if many options are set and not all of them can be recognized. Under the default setting, the check box is not checked.

For the details of command file, refer to "[3.7.2 Command file](#)".

(3) Command Line Options

This area displays the options set in this dialog box by command line options.

This area is for reference and cannot be written to.

CHAPTER 7 HEXADECIMAL CONVERTER

This chapter describes an outline of the hex converter (hx850), as well as its operation method, and output file format.

7.1 Flow of Operation

The hx850 inputs an object file output by the romp850 and converts the format of that file into a hex (hexadecimal) format.

When there is no data with initial value and the romp850 is not used, the hx850 inputs an object file output by the ld850.

Figure 7 - 1 Operation Flow in hx850

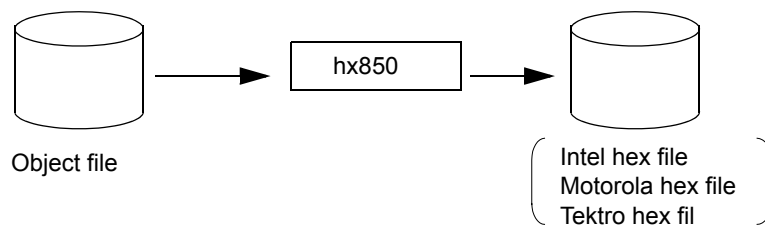

7.2 Input/Output Files

The hx850 can handle the following file as an input file.

- *file1.out* ... Executable object file output by the ld850 or romp850

The following formats can be specified as hex file formats.

- (1) Intel hex format
 - Intel expanded hex format
- (2) Tektro hex format
 - Expanded Tek hex format
- (3) Motorola hex format
 - S type format (standard address)
 - S type format (32-bit address)

Caution Addresses of lines in each hexadecimal format file are output in ascending order.

7.3 Operation Method

This section describes how the hx850 operates.

7.3.1 Command input method

Enter the following from the command prompt.

```
hx850 [option] ... file name
[ ] : Can be omitted
... : Pattern in [ ] immediately before can be repeated.
```

7.3.2 Method using PM+

The [\[Hexa Converter Options\] dialog box](#) that is used to set the hex converter options can be displayed via the following methods once a project has been established under PM+.

- Select [Tool] - [Hex Converter Options...]

Since the hex converter is activated once per project, there are no file-specific settings.

The name of the output file that is output by the hex converter is identical with the output file name from the ld850 or romp850 with the suffix changed to ".hex". To modify the name of the object file, specify a file name in "Output File[-o]" field on the [\[File\]](#) tab.

7.4 Types and Features of Options

The hx850 options are shown below.

[Symbols used in option list]

[PM+]	Option exists as specification item under the PM+.
--------------	--

7.4.1 File

This specification specifies the name of the file to be output by the hx850.

+err_file=*file*

This option adds and saves error messages to the file *file*.

-err_file=*file*

This option overwrites and saves error messages to the file *file*.

-o *ofile*

[PM+]

This option outputs the hex-converted result to the file named *ofile*.

If this option is omitted, output is standard output.

7.4.2 Format

These specifications specify an option of the hexadecimal converter.

-bnum

[PM+]

The decimal number specified as *num* is regarded as the maximum block length value (or, in the case of the Intel expanded hex format or the Motorola S type hex format, the number of code bytes indicated in one data record).

If this option is omitted, the default value for each hex format is used. Specify a decimal number or a hexadecimal number that starts with 0x or 0X as *num*.

Table 7 - 1 HEX Format Block/Record

HEX Format	Range of Specifiable Values	Default Value
Intel expanded hex format	1 - 255 (0x01 - 0xff)	31 (0x1f)
Motorola type S hex format	1 - 251 (0x01 - 0xfb)	80 (0x50)
Motorola type S hex format (32-bit address)	1 - 250 (0x01 - 0xfa)	80 (0x50)
Expanded Tek hex format	16 - 255 (0x10 - 0xff)	255 (0xff)

-dnum

[PM+]

This option offsets the address to be output from *num*.

For *num*, specify either a decimal number or a hexadecimal number that begins with either 0x or 0X.

Specifiable values are in the range of 0 to 0xffffffe.

The address output is the value offset from the specified value. The default value is 0.

-fc

[PM+]

This option specifies use of the hex format specified by the letter "c".

The significance of the letter "c" is described below.

I	Intel expanded hex format
S	Motorola type S hex format
s	Motorola type S hex format (32-bit address)
T	Expanded Tek hex format

If this option is omitted, Intel expanded hex format is used. If the -fT option is specified together with the -U option, the -U is ignored.

-Iname**[PM+]**

This option converts and outputs code in the section specified by the section name *name*. The hex converter converts in section units, not in segment units.

If a section (section having the section type NOBITS and section attribute A) is specified for the data for which no initial value has been specified, null characters (\0) are created corresponding to the section's size.

If this option is omitted, code is converted in all sections which correspond to a section type other than NOBITS and which have the section attribute ANote 3.

Spaces cannot be used in the section name. If this option is specified together with the -U option, this option is ignored.

-S**[PM+]**

This option converts and outputs symbol table portion.

This option is valid only when the extended Tek hex format has been specified (via the -fT option).

If this option is specified together with the -U option, this option is ignored.

-U**-Unum****-Unum, start, size****-Ustart, size****[PM+]**

This option converts into hex format and outputs all the codes in the area specified by address *start* to *size* size. If *start* and *size* are omitted, all the codes in the internal ROM defined by the device file are converted into hex format and output. Of the area specified, the unused area is filled with *num*. *num* can be specified by 1 or 2 bytes. If *num* is of less than 2 or 4 digits, it is assumed that as many 0s as the deficient number of digits are specified at the beginning. If *num* is omitted, the unused area is filled with 0xff.

This option must not be specified when the extended Tektronix hex format is specified. If this option is specified, the specification by the -I, -S, -f, -x, and -Z option is ignored.

-x**[PM+]**

This option makes local symbols also eligible when hex-converting and outputting the symbol table portion.

This option is valid only when the -S option has also been specified. If this option is omitted, only global symbols are eligible. If this option is specified together with the -U option, this option is ignored.

-rom_less**[PM+]**

When the -U option is specified, this option disables use of the information of the internal ROM area defined by the device file and information of the internal ROM area to be converted into hex. It also disables output of a warning message that is output if the area subject to hex conversion exceeds the internal ROM area. If this option is omitted and if *start*, *size* of the -U option is omitted, the internal ROM area defined in the device file is converted. If the area to be converted exceeds the internal ROM area, a warning message is output.

-z

[PM+]

This option generates as many null characters (\0) as the size of a section for a section with the section type NOBITS and section attribute A (section for data for which no default value is specified, such as .bss section and .sbss section). If this option is specified together with the -U option, this option is ignored.

7.4.3 Other

The specifications set other options.

-F *devpath*

[PM+]

This option sets the device file search to begin in the *devpath* folder. If this option is omitted, only the standard folders are searched.

-v

This option outputs the hx850's version information via standard error output, then terminates.

@*cfile*

This option handles *cfile* as a command file. A command file specifies an option and a file name for a command not as arguments on the command line but by describing them in a file. On Windows, the length of a character string specified as an option of a command is limited. If many options are set and some of the options cannot be recognized, create a command file and specify this option.

For details of the command file, refer to "[3.7.2 Command file](#)".

7.5 Settings Made via PM+

This section describes dialog boxes that are used to set the command option of the hx850 for the target project's source file.

7.5.1 [Hexa Converter Options] dialog box

At the upper part of this dialog box, the following three tabs are displayed.

The contents of this dialog box depend on selecting the following tab.

Table 7 - 2 [Hexa Converter Options] Dialog Box

Tab	Description
[File]	Setting of options related to a file
[Option]	Setting of hx850 options
[Others]	Other settings

Note The option shown with "[]" in this dialog box is the option that is activated from the command line.

[File]

This tab is used to set options related to a file of the hx850.

Figure 7 - 2 [Hexa Converter Options] Dialog Box ([File] Tab)

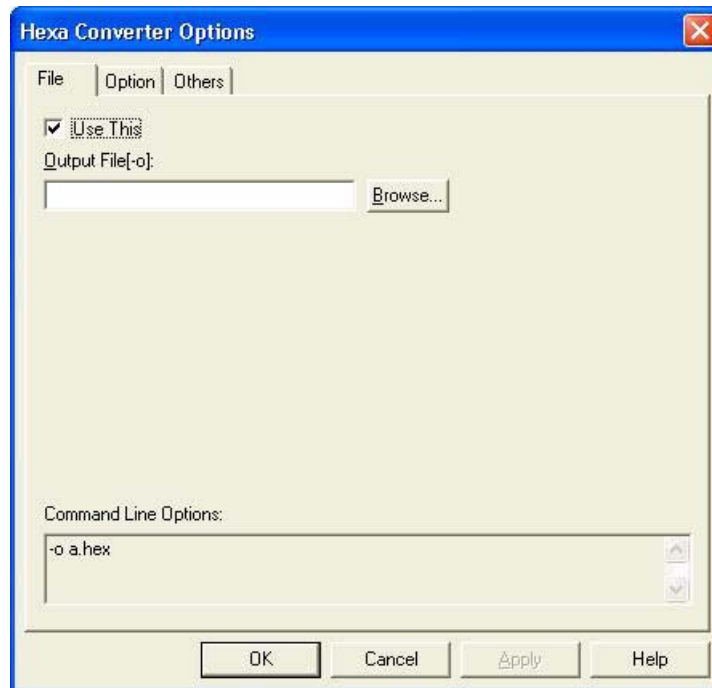

(1) Use This

If this check box is checked, the hex converter is used. This box is checked by default.

(2) Output File[-o]

This is used to specify the name of the hex file. Spaces cannot be used in a file name.

If a file name is not specified, the default output file name is the output file name for the linker (ROMization processor when the ROMization processor is started up) with the extension changed to ".hex".

To select a directive file, either click on the desired directive file or use the arrow keys. Selecting the [Browse...] button displays a dialog box, where the files can be selected.

(3) Command Line Options

This area displays the options set in this dialog box by command line options.

This area is for reference and cannot be written to.

[Option]

This tab is used to set hx850 options.

Figure 7 - 3 [Hexa Converter Options] Dialog Box ([Option] Tab)

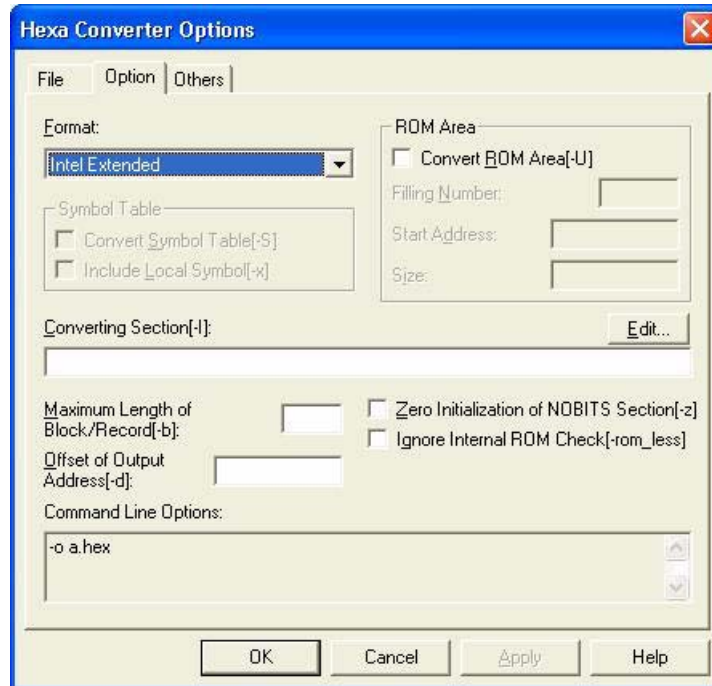

(1) Format

This option specifies the hex format to use when creating a hex file. The formats that can be specified are "Intel Extended", "Motorola Type S (Standard)", "Motorola Type S (32 bits)", and "Extended Tek". The default format is "Intel Extended".

(2) Symbol Table

This area is used to convert a symbol table. The options in this area can be specified only when the extended Tektronix format is selected in the "Format".

(a) Convert Symbol Table[-S]

This check box is used to convert and output the symbol table. This can be selected only when the extended Tektronix hex format is specified (when -fT is specified).

(b) Include Local Symbol[-x]

This check box is used to specify that local symbols are also converted when a symbol table is converted. It is valid only when it is specified together with "Convert Symbol Table[-S]". If this option is omitted, only global symbols are converted. If this option and the -U option are specified together, this option is ignored.

(3) ROM Area**(a) Convert ROM Area[-U]**

This option converts into hex format and outputs all the codes in the area of the specified size starting from the specified start address. If no start address and size are specified, all the codes in the internal ROM area defined by the device file are converted into hex format and output. Any unused are in the specified area is filled with a filling value. This option cannot be used when the extended Tektronix hex format is specified.

When this option is specified, options "[Converting Section\[-I\]](#)", "[Convert Symbol Table\[-S\]](#)", "[Include Local Symbol\[-x\]](#)", and "[Zero Initialization of NOBITS Section\[-z\]](#)" are ignored.

(b) Filling Number

A filling value of 1 or 2 bytes can be specified. Specify a filling value in hexadecimal numbers. The prefix "0x" must not be omitted. If the filling value is of less than 2 or 4 digits, it is assumed that as many 0s as the number of deficient digits are specified at the beginning. If this option is omitted, the unused area is filled with 0xff.

(c) Start Address

This option specifies the starting address of the area to be converted. Use a decimal or hexadecimal number. Be sure to specify this if "Size" is specified.

(d) Size

This option specifies the size of the area to be converted. Use a decimal or hexadecimal number. Be sure to specify this if "Start Address" is specified.

(4) Converting Section[-I]

This option specifies a section to convert to hex format. The hex converter performs conversion by section and not by segment.

If a section for which initial values of data are not specified (section having section type NOBITS and section attribute A) is specified, as many null characters (0) as the size of the section are generated. If this item is omitted, all sections that have a section type other than NOBITS and section attribute A are converted.

To specify multiple sections, separate them by ";". Selecting the [Edit...] button displays the [\[Edit Option\] dialog box](#), where section items can be edited. Spaces cannot be used in the section name.

(5) Maximum Length of Block/Record[-b]

The decimal number specified as *num* is regarded as the maximum block length value (or, in the case of the Intel expanded hex format or the Motorola S type hex format, the number of code bytes indicated in one data record).

If this option is omitted, the default value for each hex format is used. Specify a decimal number or a hexadecimal number that starts with 0x or 0X as *num*.

Table 7 - 3 HEX Format Block/Record

HEX Format	Range of Specifiable Values	Default Value
Intel expanded hex format	1 - 255 (0x01 - 0xff)	31 (0x1f)
Motorola type S hex format	1 - 251 (0x01 - 0xfb)	80 (0x50)
Motorola type S hex format (32-bit address)	1 - 250 (0x01 - 0xfa)	80 (0x50)
Expanded Tek hex format	16 - 255 (0x10 - 0xff)	255 (0xff)

(6) Offset of Output Address[-d]

This option specifies the offset of an output address as a decimal number or a hexadecimal number that begins with 0x. An output address is the offset value from a specified value. The default is 0.

(7) Zero Initialization of NOBITS Section[-z]

This option generates as many null characters (0) as the size of the section for a section that has section type NOBITS and section attribute A. (That is, a section for which initial values of data are not specified, such as the .bss section or .sbss section)

(8) Ignore Internal ROM Check[-rom_less]

When the -U option is specified, this option disables use of the information of the internal ROM area defined by the device file and information of the internal ROM area to be converted into hex. It also disables output of a warning message that is output if the area subject to hex conversion exceeds the internal ROM area. If this option is omitted and if start, size of the -U option is omitted, the internal ROM area defined in the device file is converted. If the area to be converted exceeds the internal ROM area, a warning message is output.

(9) Command Line Options

This area displays the options set in this dialog box by command line options.

This area is for reference and cannot be written to.

[Others]

This tab is used to set other options of the hx850.

Figure 7 - 4 [Hexa Converter Options] Dialog Box ([Others] Tab)

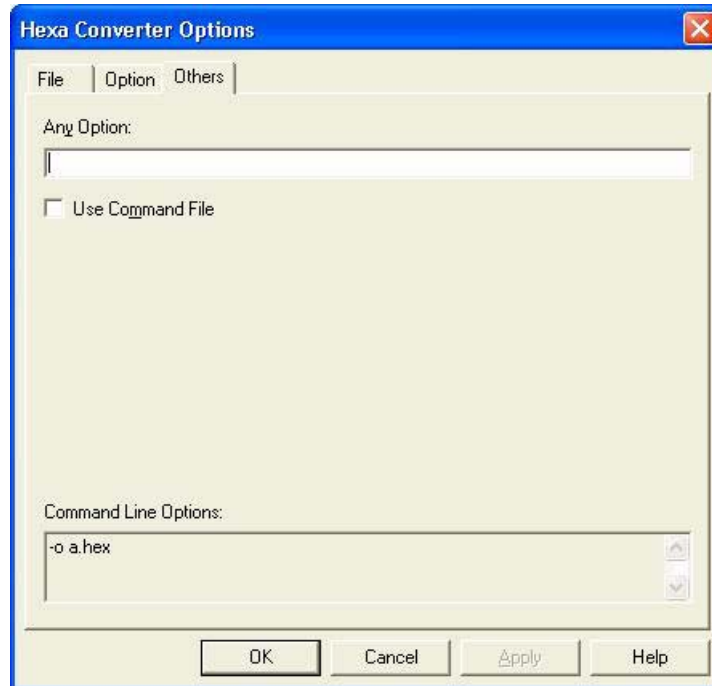

(1) Any Option

This edit box is used to specify an option other than one described above in the [Hexa Converter Options] dialog box. Describe an option in this edit box in the same format as on the command line. At present, however, no option has to be specified in this edit box because all the options related to the hex converter can be specified in the [Hexa Converter Options] dialog box.

(2) Use Command File

In the Windows environment, the length of character strings used to specify options for the ca850 is restricted. If this check box is selected, the option character string is output to a command file, which enables the operation to be completed without observing the restriction on the character string length. Check this check box if many options are set and not all of them can be recognized. Under the default setting, the check box is not checked.

For the details of command file, refer to "[3.7.2 Command file](#)".

(3) Command Line Options

This area displays the options set in this dialog box by command line options.

This area is for reference and cannot be written to.

7.6 Output File Formats

This section describes the hx850 output file formats.

7.6.1 Intel expanded

This section describes Intel expanded hexadecimal format files, which consist of four records^{Note}: the start address record, expanded address record, data record, and end record

Note Each record is output in ASCII code.

The following figure shows a file configuration in Intel expanded hex format.

Figure 7 - 5 File Configuration in Intel Expanded Hex Format

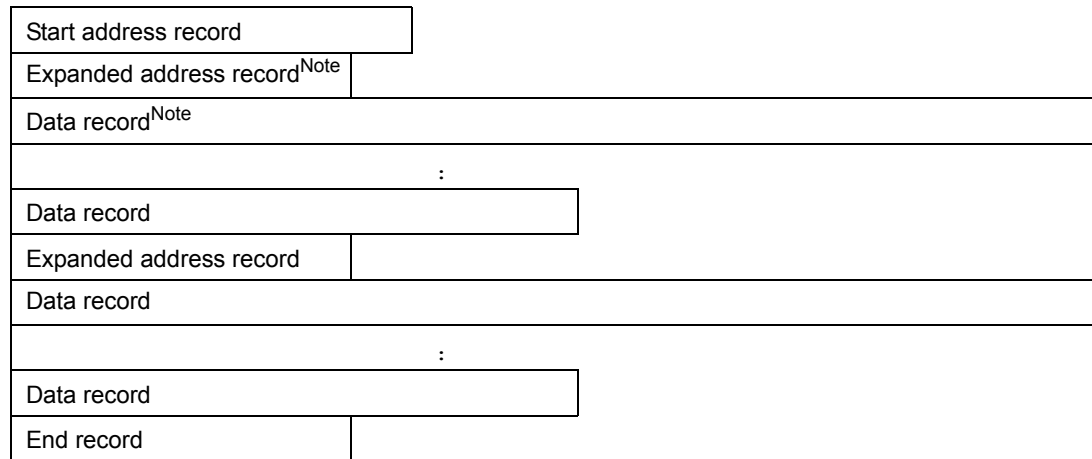

Note The expanded address record and data record are repeated.

Each record consists of the following fields.

:	CC	AAAA	TT	[field]	...	SS	NL
(a)	(b)	(c)	(d)			(e)	(f)

- (a) Record mark
- (b) Number of bytes (number of bytes that are expressed as two-digit hexadecimal numbers of [field] ...)
- (c) Location address
- (d) Record type (03: start address record, 02: expanded address record, 00: data record, 01: end record)
- (e) Checksum (value expressed as two-digit hexadecimal number in records (other than :, SS, and NL) sequentially subtracted from initial value 0 and that lower 1 byte expressed as a two-digit hexadecimal number)
- (f) New line (\n)

(1) Start address record

This record indicates an entry point address.

:	04	0000	03	PPPP	0000	SS	NL
	(a)	(b)	(c)	(d)	(e)		

- (a) Number of bytes is fixed to 04.
- (b) Fixed to 0000
- (c) Record type is 03.
- (d) Paragraph value of entry point address^{Note}
- (e) Offset value of entry point address

Note The address is calculated by (paragraph value << 4) + offset value.

(2) Expanded address record

This record indicates the paragraph value of a load address^{Note}.

Note The paragraph value is output if the segment is renewed at the beginning of a segment (when the data record is output) or when the offset value of the data record's load address exceeds the maximum value of 0xffff.

:	02	0000	02	PPPP	SS	NL
	(a)	(b)	(c)	(d)		

- (a) Number of bytes is fixed to 02.
- (b) Fixed to 0000
- (c) Record type is 02.
- (d) Paragraph value of segment

(3) Data record

This record indicates the value of a code.

:	CC	AAAA	00	DD . . . DD	SS	NL
	(a)	(b)	(c)	(d)		

- (a) Number of bytes^{Note}
- (b) Location address
- (c) Record type is 00.
- (d) Code (each byte of code expressed as two-digit hexadecimal number)

Note This is limited to the range of 0x1 to 0xff (the minimum value for the number of bytes of code indicated by one data record is 1 and the maximum value is 255).

Example

:	04	0100	00	3C58E01B	6C	NL
	(a)	(b)	(c)	(d)	(e)	

- (a) Number of bytes of 3C58E01B expressed as two-digit hexadecimal number is 04.
- (b) Location address is 0100.
- (c) Record type is 00.
- (d) Code
- (e) Checksum is 6C which is the lower 1 byte of two's complement E6 of $04 + 01 + 00 + 00 + 3C + 58 + E0 + 1B = 194$ expressed as a two-digit hexadecimal number.

(4) End record

This record indicates the end of a code.

:	00	0000	01	FF	NL
	(a)	(b)	(c)	(d)	

- (a) Number of bytes is fixed to 00.
- (b) Fixed to 0000
- (c) Record type is 01.
- (d) Checksum is fixed to FF.

[Reference] Intel hex

An allocation address in the Intel hex format is 2 bytes (16 bits). Therefore, only a 64 KB space can be directly specified. To extend this area, the Intel extended hex format adds an extension address of 16 bits so that a space up to 1 M byte (20 bits) can be used.

Specifically, a record type that specifies a 16-bit extension address is added. This extension address is shifted 4 bits and added to the allocation address to express a 20-bit address. To indicate FFFFFH, for example, F000H is set as the extension address, and FFFFH is specified as the allocation address. In the Intel extended hex format, only 0 to FFFFFH can be addressed. To express FFFFFFFH, another object format must be used.

The hx850 outputs a message if the rule of this format is violated with this address and size used. In the Intel extended hex format, a value that can be expressed is 20 bits, or 1 M byte (0x100000).

```
W8737: The start address of convert area exceeds the maximum value of the
address that can be expressed in the Intel expanded hex format
```

If the message "W8737" is output, the start address of the area to be converted into the hex format exceeds 1 M byte.

```
W8735: The address of convert area exceeds the maximum value of the address
that can be expressed in the Intel expanded hex format
```

If the message "W8735" is output, the address to be converted into the hex format exceeds 1 M byte (20 bits). The above error occurs in the following cases even if 1 M byte is not exceeded.

Example

- An offset that starts from the address specified by the -d option is not used
The absolute address is stored in the hex format.
- A section is allocated in the vicinity of the upper limit of the address that can be expressed by 20 bits
The start address fits in 20 bits but 20 bits are exceeded in the middle of the section.

If these two patterns are satisfied, the message "W8735" is output even if the area to be converted is as small as 4 bytes.

7.6.2 Motorola S type

A file in the Motorola S type hex format consists of five records^{Note 1}: S0 record as a header record, S2/S3 records as data records, and S8/S7 records as end records^{Note 2}.

The following figure shows the file configuration of the Motorola S type hex format.

Notes 1 Each record is output in ASCII code.

- 2** The Motorola S type hex formats are divided into two types: (24-bit) standard address and 32-bit address types. The format of the standard address type consists of S0, S2, and S8 records, and the format of the 32-bit address type consists of S0, S3, and S7 records.

Figure 7 - 6 File Configuration of Motorola S Type Hex Format

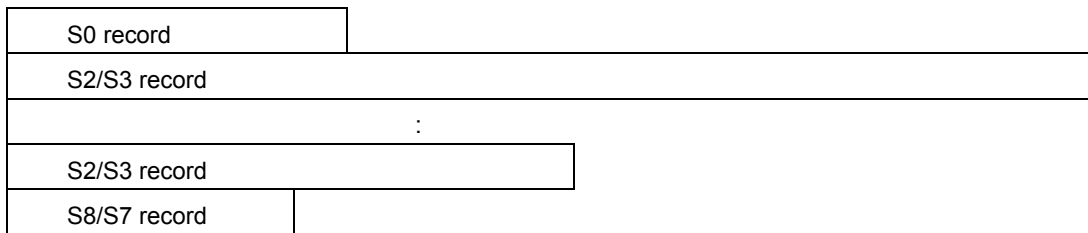

Each record format consists of the following fields.

ST	LL	field	[field]	...	SS	NL
(a)	(b)				(c)	(d)

- (a) Record type
- (b) Record length (number of bytes of field [field] ... expressed as two-digit hexadecimal number + number of bytes expressed by SS^{Note})
- (c) Checksum (Lower 1 byte expressed as two-digit hexadecimal number of one's complement of total of number of bytes in records (other than ST, SS, and NL) expressed as two-digit hexadecimal number)
- (d) New line (\n)

Note This is one.

- (1) S0 record

This record indicates a file name.

S0	LL	FF...FF	SS	NL
(a)	(b)			

- (a) Record type is S0.
- (b) File name (specified file name indicated in ASCII code)

(2) S2 record

This record indicates the value of a code.

S2	LL	AAAAAA	DD . . . DD	SS	NL
(a)	(b)	(c)			

- (a) Record type is S2
- (b) Load address (24 bits^{Note})
- (c) Code (1 byte expressed as two-digit hexadecimal number)

Note Range is 0x0 to 0xfffff.

(3) S3 record

This record indicates the value of a code.

S3	LL	AAAAAAAA	DD . . . DD	SS	NL
(a)	(b)	(c)			

- (a) Record type is S3
- (b) Load address (32 bits^{Note})
- (c) Code (1 byte expressed as two-digit hexadecimal number)

Note Range is 0x0 to 0xffffffff.

(4) S7 record

This record indicates an entry point address.

S7	LL	AAAAAAAA	SS	NL
(a)	(b)			

- (a) Record type is S7
- (b) Entry point address (32 bits^{Note})

Note Range is 0x0 to 0xffffffff.

(5) S8 record

This record indicates an entry point address.

S8	LL	AAAAAA	SS	NL
(a)	(b)			

- (a) Record type is S8
- (b) Entry point address (24 bits^{Note})

Note Range is 0x0 to 0xfffff.

7.6.3 Expanded Tek

A file in the expanded Tek hex format consists of three types of blocks: a data block, symbol block, and termination block.

The following figure shows the file configuration of the expanded Tek hex format.

Figure 7 - 7 File Configuration of Expanded Tek Hex Format

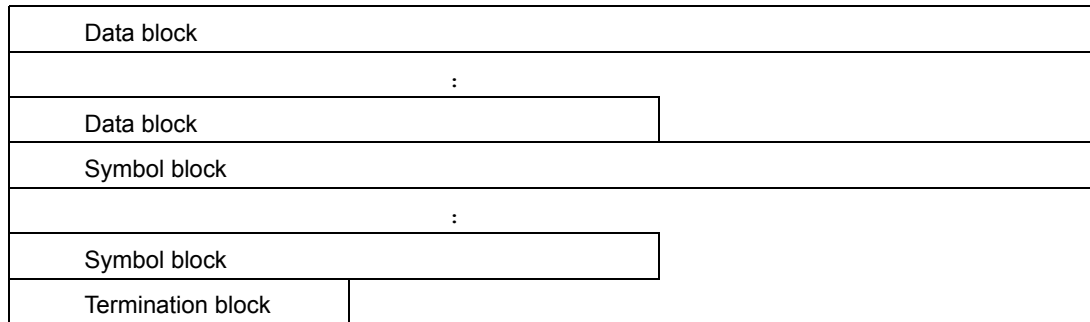

Each block consists of the following fields.

```

% LL T SS field [field] ... NL
(a) (b) (c) (d) (e)
```

- (a) Header character
- (b) Block length (number of characters in blocks other than % and NL)
- (c) Type of block^{Note 1}
- (d) Checksum (value of remainder resulting from dividing total value^{Note 2} of characters in blocks other than %, SS, and NL, by 256 and expressed as two-digit hexadecimal number)
- (e) New line (\n)

Notes 1 6 ... data block, 3 ... symbol block, 8 ... termination block

2 The value for each character is determined as follows: 0 to 9: 0 to 9, A to Z: 10 to 35, \$: 36, %: 37, .: 38, -: 39, a to z: 40 to 65).

(1) Data block

This record indicates the value of a code.

%	LL	T	SS	LA...A	D...D	NL
		(a)		(b)	(c)	

- (a) Block type is 6
- (b) Number of digits in load address and the load address
- (c) Code (one byte of code expressed as two-digit hexadecimal number)

Example

%	15	6	1C	3	1000	20202020202	NL
	(a)	(b)	(c)	(d)		(e)	

- (a) Block length is 15.
 - (b) Block type is 6.
 - (c) Checksum is 1C, which is remainder expressed as two-digit hexadecimal number that results from dividing $1 + 5 + 6 + 3 + 1 + 0 + 0 + 0 + 2 + 0 + 2 + 0 + 2 + 0 + 2 + 0 + 2 + 0 + 2 = 28$ by 256.
 - (d) Number of digits in load address is 3, and load address is 100.
 - (e) Code
- (2) Symbol block

This block indicates the value of a symbol.

%	LL	T	SS	L N...N	[SEDF ^{Note}]	SYDF	[SYDF] NL
		(a)		(b)	(A)		(B)

- (a) Block type is 3
- (b) Number of characters of the section name and the section name.

Note One section definition field must exist in each section. A section definition field can be followed by or can follow any of symbol definition fields.

(A) Section definition field (SEDF)

0	L B . . . B	L L . . . L
(a)	(b)	(c)

- (a) Indicates that this field is a section definition field.
- (b) Number of digits in the base address of a section and the base address of the section
- (c) Number of digits in the length of a section and the length of the section

(B) Symbol definition field (SYDF)

T	L S . . . S	L V . . . V
(a)	(b)	(c)

- (a) Type of symbol
 - 1: global address (symbol having binding class GLOBAL and type other than ABS)
 - 2: global scalar (symbol having binding class GLOBAL and type ABS)
 - 5: local address (symbol having binding class LOCAL and type other than ABS)
 - 6: local scalar (symbol having binding class LOCAL and type ABS)
- (b) Number of characters of symbol and the symbol
- (c) Number of digits in symbol value and value of symbol

Example1

%	37	3	60	8SVCSTUFF0	2402C6	22CR1D14OPEN25014READ25815WRITE260	NL
	(a)	(b)	(c)	(d)	(e)	(f)	

- (a) Block length is 37
- (b) Block type is 3
- (c) Checksum is 60
- (d) Number of characters of section name is 8 and the section name is SVCSTUFF.
- (e) Section definition field (number of digits in the base address of the section is 2, the base address of the section is 20, the number of digits in the length of the section is 2, and the length of the section is C6)
- (f) Symbol definition field (22CR1D/14OPEN250/14READ258/15WRITE260)

Example2

```
% 37 3 C8 8SVCSTUFF0 15CLOSE26814EXIT27029BUFLNGTH28013BUF278 NL
   (a) (b) (c) (d)           (e)
```

- (a) Block length
- (b) Block type is 3
- (c) Checksum
- (d) Number of characters of section name is 8 and section name is SVCSTUFF.
- (e) Symbol definition field
(15CLOSE268/14EXIT270/29BUFLNGTH280/13BUF278)

(3) Termination block

Indicates an entry point address.

```
% LL T SS L A...A NL
      (a) (b)
```

- (a) Block type is 8
- (b) Number of digits in entry point address and the entry point address

Example

```
% 08 8 1A 2 80 NL
   (a) (b) (c) (d)
```

- (a) Block length is 8
- (b) Block type is 8
- (c) Checksum is 1A
- (d) Number of digits in entry point address is 2, and entry point address is 80.

CHAPTER 8 ARCHIVER

This chapter describes the outline and operation of the archiver (ar850).

8.1 Archiver

The archiver is a utility that couples specified relocatable object files and generates one archive file. Therefore, this utility is used to combine two or more objects to create a "library".

In the C compiler package, "ar850" is the archiver.

Figure 8 - 1 The ar850's Operation Flow

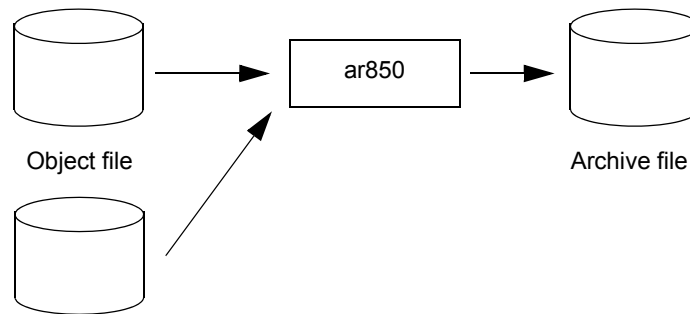

The archive file generated by the ar850 can be specified as an input file to the linker. If an archive file is specified, the ld850 searches the necessary objects from the specified archive file, and links only the objects found.

8.2 Operation Method

This section describes how the ar850 operates.

8.2.1 Command input method

Enter the following from the command prompt.

```
ar850 [±err_file=file] key [option] [member-nameNote] archive-file [member-
name or file] ...
  [ ] : Can be omitted
  ... : Pattern in [ ] immediately before can be repeated.
```

Note When files are linked within an archive file, they are called members. Each member's member name is the same as its original file name.

8.2.2 Method using PM+

To create an archive file (library file), a special project must be established under PM+. To establish the project using PM+, select the following as the microcontrollers name.

- V850 Microcontrollers
- V850 Microcontrollers Common Library
- V850 Microcontrollers Library
- V850E Core Common Library
- V850E2 Core Common Library

This establishes a project for creating an archive file (library file). At this time, the setting dialogs that can be selected via [Tools] menu are as follows:

- [\[Compiler Common Options\] dialog box](#)
- [\[Compiler Options\] dialog box](#)
- [\[Assembler Options\] dialog box](#)
- [\[Archiver Options\] dialog box](#)
- [\[Section File Generator Options\] dialog box](#)
- [\[Static performance analyzer\] dialog box](#)

Activation of the archiver is performed once for each project, and settings for each file are not necessary.

When starting the ar850 from the command line, collect a group of object files and create an archive file. Various detailed operations can be performed within archive files, such as manipulation of archive file objects.

By contrast, when using PM+ to create an archive file, start by compiling and assembling source files, then gather the resulting objects into an archive file. Operations cannot be executed within complete archive files via PM+. The user should keep this difference in mind when choosing between command-line activation and activation via PM+. The differences between command-line option settings and option settings via PM+ are described below.

8.3 Types and Features of Keys and Options

This section describes "keys" and "options". A key is an item that must be specified for activation, while an option can be omitted.

[Symbols used in key/option list]

[PM+]	Key/option exists as specification item under the PM+.
--------------	--

8.3.1 Types and features of keys

The following table lists the ar850 keys.

v

This option outputs the ar850 version number via standard output and then terminates processing.

d

This option deletes the specified member from the specified archive file.

m

This option moves the specified member to the end of the specified archive file.

ma *member*

This option moves the specified member to the position immediately after the member *member* in the specified archive file. If *member* is omitted, processing is stopped.

mb *member*

This option moves the specified member to the position immediately before the member *member* in the specified archive file. If *member* is omitted, processing is stopped.

q

This option adds the specified file to the end of the specified archive file. There is no checking as to whether or not a member with the same name as the specified file exists. If the specified archive file does not exist, a new archive file is created, and it contains the specified file.

r

This option exchanges the specified file with the member having the same name in the specified archive file. If the member with the same name as the specified file does not exist in the specified archive file, the specified file is added to the end of the specified archive file. If the specified archive file does not exist, a new archive file is created, and it contains the specified file.

ra *member*

This option exchanges the specified file with the member having the same name in the specified archive file, and then moves the specified file to the position immediately after the member *member*. If the member with the same name as the specified file does not exist in the specified archive file, the specified file is added to the end of the specified archive file. If *member* is omitted, processing is stopped.

rb *member*

This option exchanges the specified file with the member having the same name in the specified archive file, and then moves the specified file to the position immediately before the member *member*. If the member with the same name as the specified file does not exist in the specified archive file, the specified file is added to the end of the specified archive file. If *member* is omitted, processing is stopped.

ru

[PM+]

If the specified file has been updated more recently than the member having the same name in the specified archive file, this option replaces the member with the specified file. If the member with the same name as the specified file does not exist in the specified archive file, the specified file is added to the end of the specified archive file. If the specified archive file does not exist, a new archive file is created, and it contains the specified file.

t

If a member name has been specified, this option outputs only the member name of the member existing in the specified archive file. If a member name has not been specified, this option outputs (via standard output) the member names of all members existing in the specified archive file.

x

If a member name has been specified and if the specified member exists in the specified archive file, this option extracts that member and creates a file having the same name. If a member name has not been specified, this option extracts all of the members existing in the specified archive file and creates files having the same names. The contents of the archive file are not changed.

8.3.2 Types and features of options

Options can be omitted.

(1) Option list

c

[PM+]

This option does not output any messages.

v

[PM+]

This option outputs this archiver's execution status using the format "[a|d|q|m|r|x] - *file*".

a - <i>file</i>	Add
d - <i>file</i>	Delete
q - <i>file</i>	Create new
m - <i>file</i>	Move
r - <i>file</i>	Replace
x - <i>file</i>	Extract

@*cfile*

[PM+]

This option handles *cfile* as a command file. A command file specifies an option and a file name for a command not as arguments on the command line but by describing them in a file. On Windows, the length of a character string specified as an option of a command is limited. If many options are set and some of the options cannot be recognized, create a command file and specify this option.

For details of the command file, refer to "[3.7.2 Command file](#)".

(2) Error output specification options

+err_file=*file*

This option adds and saves error messages to the file *file*.

-err_file=*file*

This option overwrites and saves error messages to the file *file*.

8.4 Settings Made via PM+

This section describes each dialog for setting ar850 command options for the source file of a given project.

8.4.1 [Archiver Options] dialog box

At the upper part of this dialog box, the following one tab is displayed.

Table 8 - 1 [Archiver Options] Dialog Box

Tab	Description
[Option]	Setting of ar850 options

[Option]

This tab is used to set ar850 options.

Figure 8 - 2 [Archiver Options] Dialog Box ([Option] Tab)



(1) Archive File

This option specifies the name of the archive file to output (extension ".a"). If this option is omitted, the project file name with the extension changed to ".a" is regarded as having been specified.

It can be selected by clicking or by using arrow keys. A file also can be selected by using the dialog that is displayed by selecting the [Browse...] button.

(2) Suppress Message of File Creation[c]

Messages are not output on file creation if this option is checked.

(3) Verbose Mode[v]

This option outputs the execution status in the following format.

a - <i>file</i>	Add
d - <i>file</i>	Delete
q - <i>file</i>	Create new
m - <i>file</i>	Move
r - <i>file</i>	Replace
x - <i>file</i>	Extract

(4) Use Command File

In the Windows environment, the length of character strings used to specify options for the ca850 is restricted. If this check box is selected, the option character string is output to a command file, which enables the operation to be completed without observing the restriction on the character string length. Check this check box if many options are set and not all of them can be recognized. Under the default setting, the check box is not checked.

For the details of command file, refer to "[3.7.2 Command file](#)".

CHAPTER 9 SECTION FILE GENERATOR

This chapter describes the outline of the section file generator (sf850), the sequence for using section files, and sf850 operations.

9.1 Section Files

This section explains what section files are.

Section files are files that define the sections to which external variables (global variables) and static variables that have been declared in a C language source file are allocated. The sections to which these variables are allocated can be determined at compilation by referencing these section files. As the default setting, as many high access-frequency variables as possible are allocated to the `.tidata-attribute`, `.tidata.word-attribute`, and `.tidata.byte-attribute` sections assigned to the internal RAM area of the V850 microcontrollers.

The ca850 provides the following three methods for declaring external variables in C language source files and allocating the variables to sections.

- (1) Use the compiler option (`-Gnum`) to limit the data size when allocating to a `.sdata` section or `.sbss` section.
- (2) Use the `#pragma` section directive to determine the section for allocation of each variable.
- (3) Use section files to allocate the specified variables when the compiler is activated.

Method (1) is applicable in cases where external variables that do not exceed a certain size can be allocated to either `.sdata` or `.sbss` sections. Since this specification is via a compiler option, there is no need to add changes to the C language source file.

Method (2) enables a freer choice of the section for allocation. Here, the `#pragma` section directive is used in the C language source file to explicitly specify the target section for allocation. However, this method requires that changes be added to the C language source file.

Neither method (1) nor method (2) can be used in cases where the target section for allocation must be freely specified, such as in order to strictly comply with an ANSI standard but without having to use the `#pragma` section directive, or such as when attempting to migrate a C language source file that has been compiled by a compiler other than the ca850 without adding changes to the C language source file.

Method (3) involving section files is recommended in such cases.

Section files define the following for all external variables and static variables:

- C language source files where the static variables are declared
- external variable names, static variable names, and names of the sections where they are allocated

Also, by having the section files referenced by the compiler, the variables can be allocated to the intended locations without having to modify the C language source file.

With the ca850, specification of a compiler option (`-Xcre_sec_data` or `-Xcre_sec_data_only`) generates a frequency information file, which can be input to the section file generator (sf850) to create a section file. However, the sf850 is designed to output information for allocating data to `tidata-attribute`, `tidata.word-attribute`, and `tidata.byte-attribute` sections that are intended to be allocated in the internal RAM of V850 microcontrollers devices. Since section files are text-format files, they can be edited and modified by using an editor. In other words, changes can be made in this way to the section files that are output by the sf850 in order to create the final (completed) section files.

When compilation is performed once again using the completed section file (with the `-Xsec_file` option specified), the result is a complete object file whose external variables and static variables are allocated to the specified sections.

Figure 9 - 1 Image of Compilation Using Section File Specifications

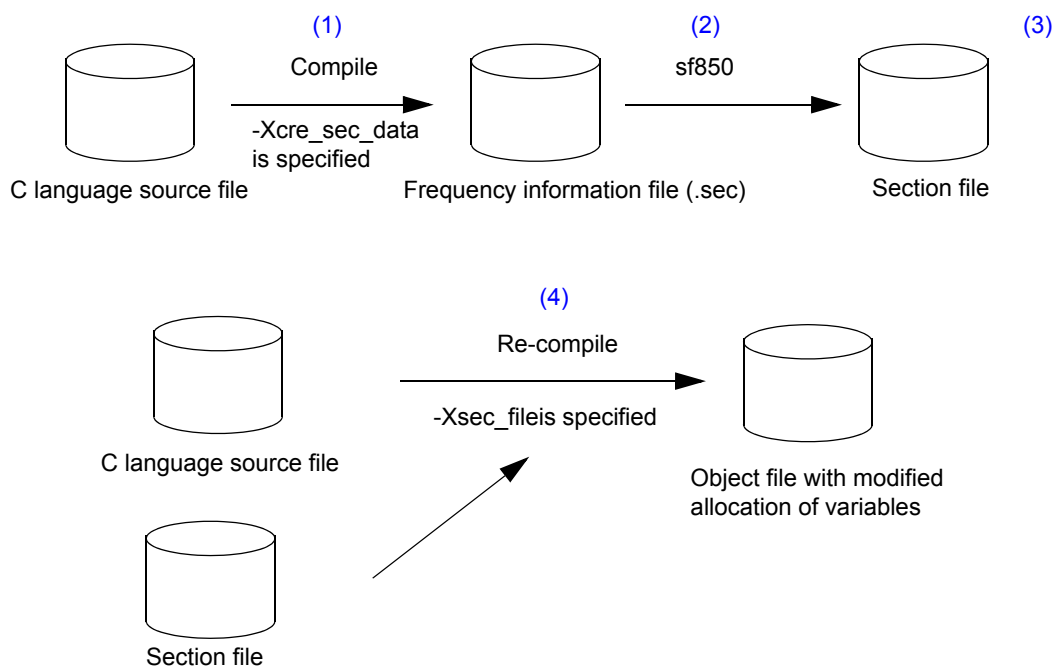

- (1) Compile once using `-Xcre_sec_data` option to create a section file.
- (2) Use the sf850 to convert the frequency information file into a section file.
- (3) Edit the section file, if necessary.
- (4) Compile once more using `-Xsec_file` option to input the section file.

For description of the section file's format, refer to "9.2 Section File Format".

The variables whose allocation can be specified via section files are external variables (global variables), static variables in files (static variables that are declared within a file), and static variables in functions (static variables that are declared within a function). Allocation specifications cannot be made using character string constants (such as "abc").

When compiling each of several C language source files and linking them to create an object file, compile each file after specifying its frequency information output, which creates several .sec files. However, when creating these section files, the .sec files must be input to the sf850 all at once and then integrated. Otherwise, the variable information for the external variables will not be integrated, and valid section files cannot be created.

The variable specified by the section file is equivalent to specifying "#pragma section". Therefore, a temporary definition of an external variable is handled as a "definition", so if an external variable is temporarily defined by two or more files, an error occurs during linking. In such cases, extern must be always declared in a file that references external variables.

If a variable whose allocation has been specified via a section file has also been specified (via a #pragma section directive in a C language source file) to be allocated to a different section, the specification via the section file takes priority. Even when the "-Gnum" compiler option has been specified, if a section file specifies that the target will be allocated to an .sdata section or .sbss section, it will be allocated to that section regardless of the num value. In other words, the order of priority among the specifications "section file" specification, "#pragma section" specification, and "-Gnum" specification is as follows.

(← Higher priority) Section file > #pragma section > -Gnum (lower priority →)

9.2 Section File Format

Section files are text files that are input at compile time to revise the sections where variables are to be allocated. They enable variable allocation settings to be changed without having to modify any C language source files. Allocation specifications made via section files take priority over specifications made via #pragma section directives in C-language source programs.

The ca850 enables the user to specify which section files will be output to the sf850 at compile time. The sf850 merges the information from several files that have been input and outputs a single section file as specified via the ca850's options.

The following figure shows an example of a section file output by the sf850.

Figure 9 - 2 Example of Section File Output by sf850

```
//Created by sf850. at Thu Jan 22 17:26:25 2004
[tidata]
// [file:[func:]]variable // section size total_freq Byte_freq Word_freq
"main.c:val1" // data 4 10 10 0
"main.c:val2" // data 4 8 8 0
"main.c:func1:val3" // -4 5 5 0
"i" // -4 3 3 0
"j" // -2 1 1 0
```

On each line, all content that follows "/" is regarded as comments.

Variables are displayed in section files as shown below.

```
[Section type]
"file-name:function-name:variable-name" //comment
"file-name:variable-name" // comment
"variable-name" // comment
```

There are three ways to display variables, according to the type of variable. The variable types and display variations are listed below.

Table 9 - 1 Variable Types and Displays

Display	Meaning
file-name : function-name : variable-name	Static variable declared in a function. The function name and file name are also displayed.
file-name : variable-name	Static variable declared in a file. The file name is also displayed.
variable-name	External variable. Only the variable name is displayed.

Comments are output in the following format.

```
section size total_freq Byte_freq Word_freq
```

The displayed variables and their meanings are listed below.

Table 9 - 2 Variable Displays and Their Meanings

Display	Meaning
section	Section to which allocation of the variable is explicitly specified. If the variable is not explicitly specified, "-" is displayed.
size	Size of variable (in bytes). If the size is unknown, "0" is displayed.
total_freq	Frequency of variable references. This indicates the number of load/store instructions that have appeared for a particular variable.
Byte_freq	For the given variable reference frequency, this indicates the number of variable references in byte units.
Word_freq	For the given variable reference frequency, this indicates the number of variable references in word units.

The sf850 outputs a section file in which all variables are allocated to the .tidata section. Since the .tidata section's memory capacity is 256 bytes, if the variables exceed that amount they must be revised as determined on the user side.

However, if the -O option is specified, the file can be input to the ca850 as it is because the variables will be sorted according to use frequency and only the more frequently used variables will be included up to the .tidata section's capacity. Also, when specifying the -O option, the user can choose to have the output sent to "tidata_word" and "tidata_byte" instead of just "tidata".

The following figure shows a section file example output when the "-O option" is specified.

Figure 9 - 3 Example of Section File Output by sf850 Using -O Option

```
// Created by sf850. at Thu Jan 22 17:26:25 2004
[tidata_byte]
// [file:[func:]]variable // section size total_freq Byte_freq Word_freq
"a.c:si1" // data 4 10 10 0
"a.c:si2" // data 4 8 8 0
"a.c:f1:sfil" // - 4 5 5 0
"i" // -4 3 3 0
"J" // -2 1 1 0
[tidata_word]
"a.c:si3" // data 4 10 0 10
"a.c:si4" // data 4 8 0 8
"a.c:f1:sfi2" // -4 5 2 3
"l" // -4 3 2 1
"m" // -2 1 0 1
```

The specifiable types of output sections include other types besides `tidata-attribute` sections, `tidata.word-attribute` sections, and `tidata.byte-attribute` sections.

The following character strings can be used to specify section types.

Table 9 - 3 Types of Sections Specifiable by `ca850`

Type Specification Character String	Target Section for Allocation
<code>tidata</code>	Byte data for which a default value has been set is allocated to the <code>.tidata.byte</code> section and half-word (or larger) data for which a default value has been set is allocated to the <code>.tidata.word</code> section. Byte data for which a default value has not been set is allocated to the <code>.tibss.byte</code> section and half-word (or larger) data for which a default value has not been set is allocated to the <code>.tibss.word</code> section.
<code>data</code>	If a default value has been set, allocation is to the <code>.data</code> section. If a default value has not been set, allocation is to the <code>.bss</code> section.
<code>sdata</code>	If a default value has been set, allocation is to the <code>.sdata</code> section. If a default value has not been set, allocation is to the <code>.sbss</code> section.
<code>sedata</code>	If a default value has been set, allocation is to the <code>.sedata</code> section. If a default value has not been set, allocation is to the <code>.sebss</code> section.
<code>sidata</code>	If a default value has been set, allocation is to the <code>.sidata</code> section. If a default value has not been set, allocation is to the <code>.sibss</code> section.
<code>const</code>	Allocation is to the <code>.const</code> section.
<code>sconst</code>	Allocation is to the <code>.sconst</code> section.

[Cautions]

- Do not insert blank spaces before or after a section name when specifying the section name in square brackets ([]).
For example, in the case of [tidata], blank spaces cannot be inserted before or after "tidata".
- Enclose a variable name in a section file with "(double quote)". The format of CA850 Ver. 2.60 or earlier can be used.
- Only one variable can be used per line. Do not modify the code to specify two or more variables per line and do not make one variable specification occupy more than one line.
- Do not insert blank spaces before or after ":".
- Do not specify the path when specifying file names.
- If a function or variable definition is included in a header file, the "file name" in the section file is not the header file name; it is the C language source file name that includes the header file.
- Comments in the form of "/* */" or "/*" can be inserted. However, a section name or variable name must not be delimited by a comment. A blank space is required immediately after a variable name.
ASCII code and EUC (Japanese) code can be used in comments.
- If a variable for which "data" has been specified as the section type in a section file is referenced by another assembly language source file, use the .option quasi directive to specify "data" so that the assembler will be notified of the data/bss attribute. Also, if a variable for which "sdata" has been specified is referenced by another assembly language source file, use the .option quasi directive to specify "sdata" so that the assembler will be notified of the sdata/sbss attribute.

Example

```
// Section file
[data]
"a.c:dat1"      // With default value; allocation is to .data section.
"b.c:dat2"      // Without default value; allocation is to .bss section.
[sdata]
"a.c:sdat1"     // With default value; allocation is to .sdata section.
"b.c:sdat2"     // Without default value; allocation is to .sbss section.

# Assembly language source file
.option data _dat1
.text
    mov $_dat1, r11
    -- Allocation to .data section is assumed; instruction is expanded.
.option data _dat2
.text
    mov $_dat2, r12
    -- Allocation to .bss section is assumed; instruction is expanded.
.option sdata _sdat1
.text
    mov $_sdat1, r13
    -- Allocation to .sdata section is assumed; instruction is not expanded.
.option sdata _sdat2
.text
    mov $_sdat2, r14
    -- Allocation to .sbss section is assumed; instruction is not expanded.
```

9.3 Operation Method

The following describes how to use section files when activating either from the command line or from PM+.

9.3.1 Command input method

Enter the following from the command prompt.

```
sf850 [option] ... file1 [file2]...  
[ ] : Can be omitted  
... : Pattern in [ ] immediately before can be repeated
```

9.3.2 Method using PM+

The [\[Section File Generator Options\] dialog box](#) that is used to set the section file generator options can be displayed via the following methods once a project has been established under PM+.

- Select [Tool] - [Section File Generator Options...]

Since the section file generator is activated once per project, there are no file-specific settings

The default name of the section file that the section file generator outputs is the project file name with the extension changed to ".sf". It also is possible to use an option to specify the output file name.

Note that when starting the section file generator from PM+, check "Use This" in the [\[File\]](#) tab in the [\[Section File Generator Options\] dialog box](#).

9.3.3 Use from command line

The following describes how to use section files from the command line.

- (1) First, create a frequency information file. Specify the ca850 option "-Xcre_sec_data_only" and compile the C language source file to create a frequency information file for the external variables and static variables in the C language source file. The file's default file name is the C language source file name with the suffix ".sec". To specify a particular file name for the frequency information file, specify the file name when specifying the "-Xcre_sec_data_only" option.

Example

```
> ca850 -cpu 3201 -Xcre_sec_data_only=secsrc func1.c
```

In this case, a frequency information file for the C language source file "*func1.c*" is output as "*secsrc*".

- (2) Input the generated frequency information file to the sf850, which outputs a section file. In this case, the generated section file specifies that variables will be allocated to *tidata-attribute* sections, *tidata.word-attribute* sections, and *tidata.byte-attribute* sections.

Example

```
> sf850 func1.sec func2.sec func3.sec -o secfile
```

In this case, the three frequency information files *func1.sec*, *func2.sec*, and *func3.sec* are gathered as one section file, which is output as "*secfile*". It is easier to create a command file in cases where there are a lot of files and consequently a lot of file names to enter. For details of command files, refer to "[3.7.2 Command file](#)".

- (3) Since the default specification for the output section file is that all variables are allocated to a *.tidata-attribute* section, it may be necessary to modify the section file. If the -O option is specified when activating sf850, the variables that can be accommodated in the memory range of the *.tidata* section can be automatically selected in sequence, starting from the most frequently referenced variable.
- (4) Re-compile the C language source file by specifying the ca850 option "-Xsec_file". As a result of re-compiling, a section-allocated object file is created in accordance with the input section file.

Example

```
> ca850 -cpu 3201 -Xsec_file secfile func1.c func2.c func3.c
```

In this case, *secfile* is input as a section file and *func1.c*, *func2.c*, and *func3.c* are compiled.

9.3.4 Use via PM+

This section explains a method for using section files via PM+.

When operating from PM+, check "Use This" in the [File] tab that is displayed using the "[Section File Generator Options] dialog box" menu. This causes the ca850 to create a frequency information file and then automatically start sf850 to generate a section file, which it then uses to compile.

A section file output using the above method specifies allocating all variables to a section that has the .tidata attribute. If a section file is to be revised and used, this must be done using the following method and not checking "Use This".

- (1) First, create a frequency information file. Select "[Compiler Options] dialog box" from the menu and then select the [Output File] tab and check the "Frequency Information File[-Xcre_sec_data]". If a file name is specified in the combo box, the name of a file to which frequency information is to be output can be specified. A frequency information file must be created for each C language source file. If, as in the example shown above, the frequency information file specification applies to all C language source files (i.e., is not specified for a particular source file), the frequency information in the func1.sec file will be overwritten each time a C language source file is compiled. In other words, the final func1.sec file will contain only the information for the C language source file that was compiled last. If no frequency information file name is specified, the output frequency information file's file name becomes the C language source file's file name with the suffix ".sec", and this enables a separate frequency information file to be created for each C language source file. This means that when creating all of the frequency information files, it is better not to specify a file name unless you wish to specify particular file names as options for particular C language source files.
- (2) Input the generated frequency information file to the sf850, which outputs a section file. Consequently, the sf850 must be activated via the command line. Once this is done, a section file which specifies the variables that will be allocated to tidata-attribute sections, tidata.word-attribute sections, and tidata.byte-attribute sections is generated.

Example

```
sf850 func1.sec func2.sec func3.sec -o secfile
```

In this case, the three frequency information files *func1.sec*, *func2.sec*, and *func3.sec* are gathered as one section file, which is output as "secfile". It is easier to create a command file in cases where there are a lot of files and consequently a lot of file names to enter. For details of command files, refer to "3.7.2 Command file".

- (3) Since the default specification for the output section file is that all variables are allocated to a .tidata-attribute section, it may be necessary to modify the section file. If the -O option is specified when activating sf850, the variables that can be accommodated in the memory range of the .tidata-attribute section can be automatically selected in sequence, starting from the most frequently referenced variable.
- (4) Select "[Compiler Options] dialog box" from the menu and then select the [Input File] tab and specify the generated section file name in the combo box of "Section File[-Xsec_file]", then rebuild. The build will result in the creation of a section-allocated object file in accordance with the input section file.

9.4 Types and Features of Options

The sf850 options are shown below.

[Symbols used in option list]

[PM+]	Option exists as specification item under the PM+.
--------------	--

9.4.1 Options

This specifies options of the sf850.

-o

[PM+]

This option specifies that only the number of variables that can be allocated to the .tidata section will be selected, in order starting from highest use frequency and output.

The maximum data size that can be allocated to the .tidata section is 256 bytes, which are internally divided into .tidata.byte byte data (128 bytes) and .tidata.word word data. When this option is specified, variables are selected until the total section size of 256 bytes is reached, at which point the variables are output to the section file. However, selection is stopped when the byte data reaches 128 bytes. If this option is omitted, all variables that have appeared are output to the section file.

-v

This option outputs the section file generator's version number via standard output and then terminates processing.

-Xcs [=name]

[PM+]

This option excludes variables allocated to a section from optimization when the -O option is specified as *name*. A *name* is specified a section file to the specified the link directive file. Please .bss/.sbss or bss attribute section replace .data/.sdata. If *name* is omitted, all section names are specified. If the ".tidata" is specified the *name*, the user can choose to have the output sent to ".tidata.word" and "tidata.byte" instead of just ".tidata".

-Xcv=name

[PM+]

This option excludes variables from optimization when the -O option is specified as *name*. A *name* is specified with the same from as a [Table 9 - 1](#).

-c1 num

[PM+]

This option specifies the comment level of the section file to be output. The following values can be specified as *num*.

0	No output of comments
1	Outputs file creation information (date, etc.), variable information, and corresponding descriptions. The variable information includes the section name, size, and use frequency. If the section name is not determined by an external variable, "-" is output.
2	Outputs a format guide in addition to level 1. If -O has been specified, variables judged not to fit in the .tidata section are output as comments.

If this option is omitted, comment level 1 is assumed.

+err_file=file

This option adds and saves error messages to the file *file*.

-err_file=file

This option overwrites and saves error messages to the file *file*.

-h

-help

This option outputs a description of the section file generator's options via standard output and then terminates processing.

-ns

[PM+]

This option arranges variable names in section files to be output in the order they appear instead of sorting them. If this option is omitted, the variable names are arranged in order of highest use frequency. If two variable names have the same use frequency, they are arranged so that the smaller of the two is first.

-o name

[PM+]

This option specifies the section file name to be output as *name*.

If this option is omitted, the section file is output via standard output.

-size_tidata=num

[PM+]

This option specifies the upper size (*num* bytes) limit of variables allocated to the *tidata.word/tidata.byte* section when the **-O** option is specified.

-size_tidata_byte=num

[PM+]

This option specifies the upper size (*num* bytes) limit of variables allocated to the *tidata.byte* section when the **-O** option is specified.

-sname

[PM+]

This option arranges the variable names in section files to be output according to the dictionary order of variable names. If two variables have the same name, they are arranged according to the dictionary order of file names and function names.

-ssection

[PM+]

This option arranges the variable names in section files to be output according to their size (smallest first). If two variables have the same size, they are arranged in order of highest use frequency.

-ssize

[PM+]

This option arranges the variable names in section files to be output according to their size (smallest first).

If two variables have the same size, they are arranged in order of highest use frequency.

-v

[PM+]

This option displays the section file generator's execution process.

@cfile

[PM+]

This option handles *cfile* as a command file. A command file specifies an option and a file name for a command not as arguments on the command line but by describing them in a file. On Windows, the length of a character string specified as an option of a command is limited. If many options are set and some of the options cannot be recognized, create a command file and specify this option.

For details of the command file, refer to "[3.7.2 Command file](#)".

[Cautions]

Some of the above options are invalid if specified concurrently with other options.

- If two or more options related to sorting (-o or -cl) are specified, the one specified last is valid and the others are invalid.
- If -V, -h, and/or -help are specified at the same time, the one specified first is valid, and the others are invalid.
- If -O and an option related to sorting are specified at the same time, -O is valid and the option related to sorting is invalid.
- The CA850's output that results when frequency information files are input to the sf850 should be used as it is. Operation is not guaranteed if a frequency information file with modified content has been input.

For description of the contents of section files output by the sf850, refer to "[9.2 Section File Format](#)".

9.5 Settings Made via PM+

This section describes each dialog for setting sf850 command options for source files of a given project.

9.5.1 [Section File Generator Options] dialog box

At the upper part of this dialog box, the following three tabs are displayed.

The contents of this dialog box depend on selecting the following tab.

Table 9 - 4 [Section File Generator Options] Dialog Box

Tab	Description
[File]	Setting of options related to a file
[Option]	Setting of sf850 options
[Others]	Other settings

Note The option shown with "[]" in this dialog box is the option that is activated from the command line.

Caution The generated file is deleted if the section file generator options are changed.

To edit and use, copy it to a separate file then use.

[File]

This tab is used to set options related to a file of the sf850.

Figure 9 - 4 [Section File Generator Options] Dialog Box ([File] Tab)

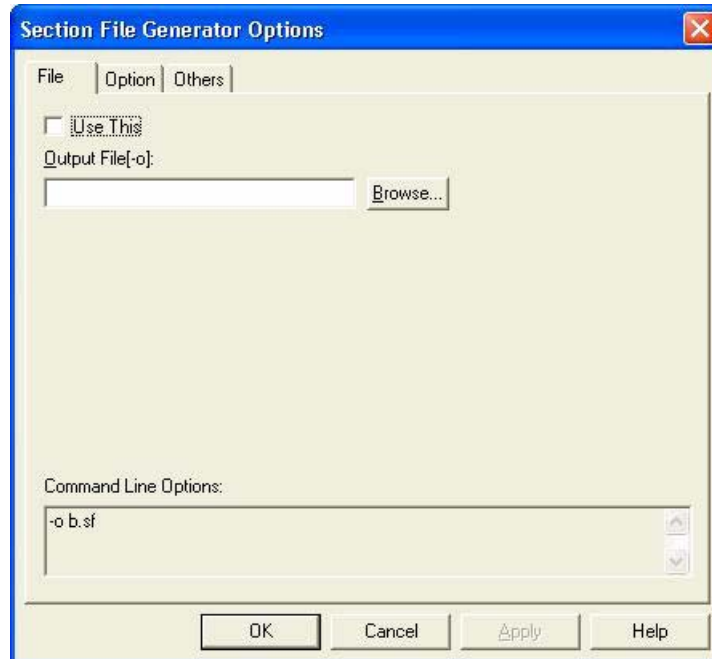

(1) Use This

This check box is used to specify whether a section file generator is used for build. If it is checked, the section file generator is used. If it is used, a frequency information file ".sec" is created for all C language source files in the project folder or work folder.

(2) Output File [-o]

This option specifies the name of the section file to output (extension ".sf"). Spaces cannot be used in the file name. Specifying a file name is the same as specifying it in the -o option.

If a file name is not specified, the project file name with the extension changed to ".sf" is regarded as having been specified.

A file also can be selected by using the dialog that is displayed by selecting the [Browse...] button.

(3) Command Line Options

This area displays the options set in this dialog box by command line options.

This area is for reference and cannot be written to.

[Option]

This tab is used to set sf850 options.

Figure 9 - 5 [Section File Generator Options] Dialog Box ([Option] Tab)

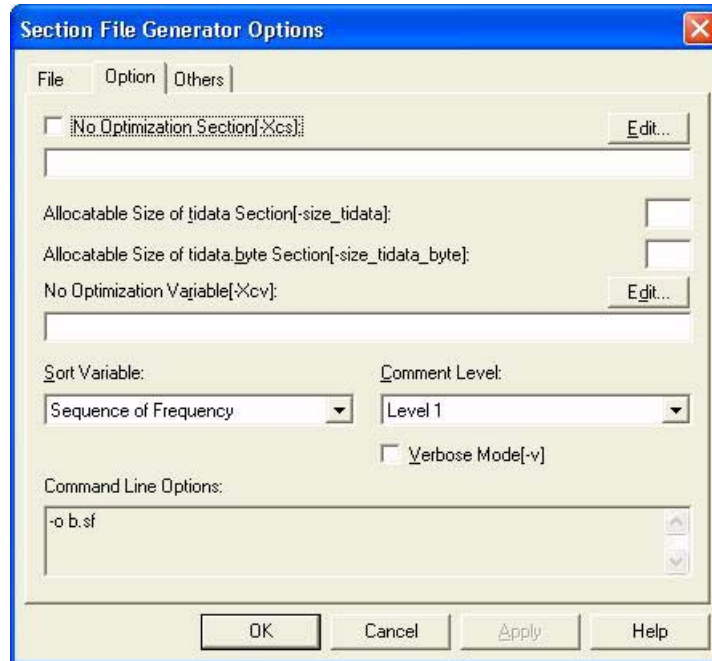

(1) No Optimization Section[-Xcs]

This option excludes variables allocated to a section from optimization when the "Optimize Location[-O]" is specified. If this check box is checked, it is assumed that all sections are specified. If a section is specified in the edit box below, the variable allocated to that section is excluded from optimization. To specify two or more sections, delimit each by ";" (semicolon). Selecting the [Edit...] button displays the [Edit Option] dialog box. Sections can be edited in this dialog box.

(2) Allocation Size of tidata Section[-size_tidata]

This option specifies the upper size limit of variables allocated to the tidata.word/tidata.byte section when the "Optimize Location[-O]" option is specified. Specify size in decimal numbers.

(3) Allocation Size of tidata.byte Section[-size_tidata_byte]

This option specifies the upper size limit of variables allocated to the tidata.byte section when the "Optimize Location[-O]" option is specified. Specify size in decimal numbers.

(4) No Optimization Variable[-Xcv]

This option excludes variables from optimization when the -O option is specified. To specify two or more variables, delimit each by ";" (semicolon). Selecting the [Edit...] button displays the [Edit Option] dialog box. Variables can be edited in this dialog box.

(5) Sort Variable

This option specifies options related to sorting variables.

(a) Does Not Sort[-ns]

Variable names in the output section file are not sorted, but are listed in the order in which they appeared.

(b) Sequence of Frequency

Variables are sorted in descending order of frequency of use (default). When the frequency of use is the same, variables are listed in ascending order of size.

(c) Variable Name[-sname]

The variable names in the output section file are listed in alphabetical order. When variable names are the same, they are listed in alphabetical order of file name and function name.

(d) Section Name[-ssection]

The names of sections to which the variable names in the output section file are allocated are listed in alphabetical order. When section names are the same, they are listed in descending order of frequency of use.

(e) Variable Size[-ssize]

The variable names in the output section file are listed in ascending order of size. When sizes are the same, they are listed in descending order of frequency of use.

(f) Optimize Location[-O]

Determine how many variables can be allocated to the .tidata.byte section or .tidata.word section and output them in descending order of frequency of use. 256 bytes can be allocated in the .tidata section and this is divided internally into the byte data of .tidata.byte (128 bytes) and the word data of .tidata.word. 8-bit data can be allocated only to the .tidata.byte area. The section file generator selects variables and outputs them in the section file until their total is 256 bytes. However, it terminates selection when 8-bit data reaches 128 bytes.

(6) Comment Level

This option specifies the comment level of the output section file.

(a) Not Output[-cl 0]

Do not output comments.

(b) Level 1

Output date and other file creation information, as well as variable information and its explanation (default). Variable information is section name, size, and frequency of use. If the section name is not determined for an external variable, "-" is output.

(c) Level 2[-cl 2]

In addition to Level 1, output a format guide. If "Optimize Location" is specified, variables determined not to be in the .tidata section also are output as comments.

(7) Verbose Mode[-v]

This option displays the execution status of the section file generator.

(8) Command Line Options

This area displays the options set in this dialog box by command line options.

This area is for reference and cannot be written to.

[Others]

This tab is used to set other options of the sf850.

Figure 9 - 6 [Section File Generator Options] Dialog Box ([Others] Tab)

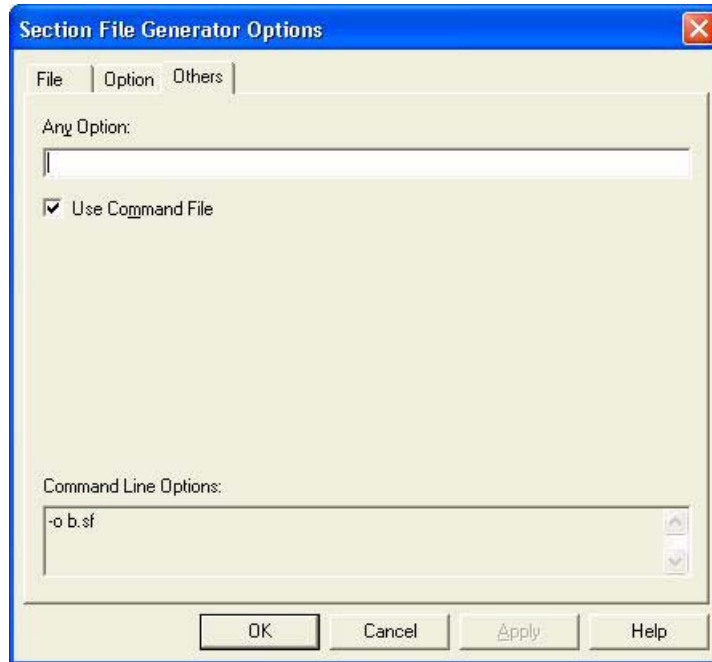

(1) Any Option

This edit box is used to specify an option other than one described above in the [Section File Generator Options] dialog box. Describe an option in this edit box in the same format as on the command line. At present, however, no option has to be specified in this edit box because all the options related to the section file generator can be specified in the [Section File Generator Options] dialog box.

(2) Use Command File

In the Windows environment, the length of character strings used to specify options for the ca850 is restricted. If this check box is selected, the option character string is output to a command file, which enables the operation to be completed without observing the restriction on the character string length. Check this check box if many options are set and not all of them can be recognized. Under the default setting, the check box is not checked.

For the details of command file, refer to "[3.7.2 Command file](#)".

(3) Command Line Options

This area displays the options set in this dialog box by command line options.

This area is for reference and cannot be written to.

CHAPTER 10 DUMP COMMAND

This chapter describes the outline, operation, and display format of the dump command (dump850).

10.1 Dump Command

A dump command displays the contents or information of a specified object file or archive file. It is used to check information such as the address, attribute, and symbol name of a section/segment in a created object file or archive file.

The dump command of the C compiler package is "dump850".

Figure 10 - 1 Operation Flow of dump850

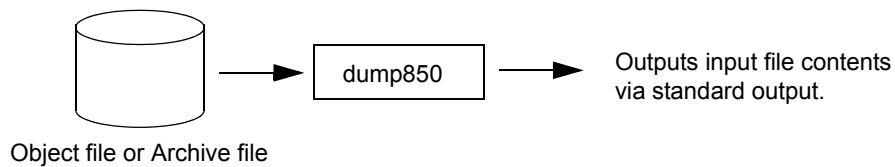

If an archive file is input to the dump command, and if a member that is not an object file exists in the archive file, a warning message is output and the next member is processed; except, however, when the -e option is specified.

For details of the options, refer to "[10.3 Types and Features of Options](#)".

10.2 Operation Method

This section describes how to operate the dump850 command.

10.2.1 Command input method

Enter the following from the command prompt.

```
dump850 [option] ... file1 [file2] ...  
[ ] : Can be omitted  
... : Pattern in [ ] immediately before can be repeated.
```

10.2.2 Method using PM+

The [\[Object Analysis Tool\] dialog box](#) that is used to activate the dump command can be displayed via the following methods once a project has been established under PM+.

- Select [Tool] - [Startup Object Analysis Tool...], then click the [\[Dump\]](#) tab

Since the dump command is activated once per project, there are no file-specific settings.

10.3 Types and Features of Options

The dump850 options are shown below.

-A

This option displays the entire contents of the specified object file or archive file. Specifying the -A option is the same as specifying "-abcfghiklmrst".

If no option is specified, it is assumed that the -A option is specified.

-T

This option does not display the member update date among the displayed archive header contents.

-v

This option outputs the dump850 version number to standard output and then terminates processing.

-a

This option displays the archive header contents of all members existing in the specified archive file.

-b

This option displays the contents of debug information.

-c

This option displays the contents of the string table.

-d *num*

This option displays data from the section indicated by the section header table index *num*.

+d *num*

This option displays data up to the section indicated by the section header table index *num*.

-e

This option displays the contents of members (other than archive symbol table, archive string table, or object file) existing in the specified archive file.

-f

This option displays the ELF header contents of all members existing in the specified archive file.

-g

This option displays the external symbol contents of the archive symbol table existing in the specified archive file.

-h

This option displays the contents of all section headers existing in the specified archive file.

-i

This option displays the contents of all program headers existing in the specified archive file.

-k

This option displays the contents of the global pointer table.

-l

This option displays the line number information.

-m

This option displays the contents of strings existing in the archive string table for the specified archive file.

-n *name*

This option displays the contents of the section indicated by section name *name*.

-p

This option does not display the title.

-r

This option displays the contents of relocation information.

-s

This option displays the contents of the section.

-t [*num*]

This option displays the contents of a symbol table starting from the *num*th symbol table entry. If *num* is omitted, the display starts from the first symbol table entry.

+t *num*

This option displays the contents of a symbol table up to the *num*th symbol table entry.

-v

This option displays a value, such as for a section attribute value, using a character string to indicate the meaning of the value rather than a number (refer to "[10.5.2 Element values and meanings](#)").

-z *name* [*num*]

This option displays contents of line number information for the function name, starting from the *num*th line number entry. If *num* is omitted, the display starts from the first line number entry.

+z *num*

This option displays contents of line number information, up to the *num*th line number entry.

@*cfile*

This option handles *cfile* as a command file. A command file specifies an option and a file name for a command not as arguments on the command line but by describing them in a file. On Windows, the length of a character string specified as an option of a command is limited. If many options are set and some of the options cannot be recognized, create a command file and specify this option.

For details of the command file, refer to "[3.7.2 Command file](#)".

10.4 Settings Made via PM+

This section describes the dialog box that is used to set the command options of the dump850 for the target project's C language source files.

10.4.1 [Object Analysis Tool] dialog box

At the upper part of this dialog box, the following three tabs are displayed.

The contents of this dialog box depend on selecting the following tab.

Table 10 - 1 [Object Analysis Tool] Dialog Box (dump850)

Tab	Description
[Dump]	Setting of options related to dump command
[Disassembler]	Setting of options related to disassembler
[RAM map]	Setting of options related to RAM map

[Dump]

For the dump command activation dialog box, set the project settings in the PM+, then select the [Dump] tab in the dialog opened by selecting [Tool] - [Startup Object Analysis Tool...].

Figure 10 - 2 [Object Analysis Tool] Dialog Box ([Dump] Tab)

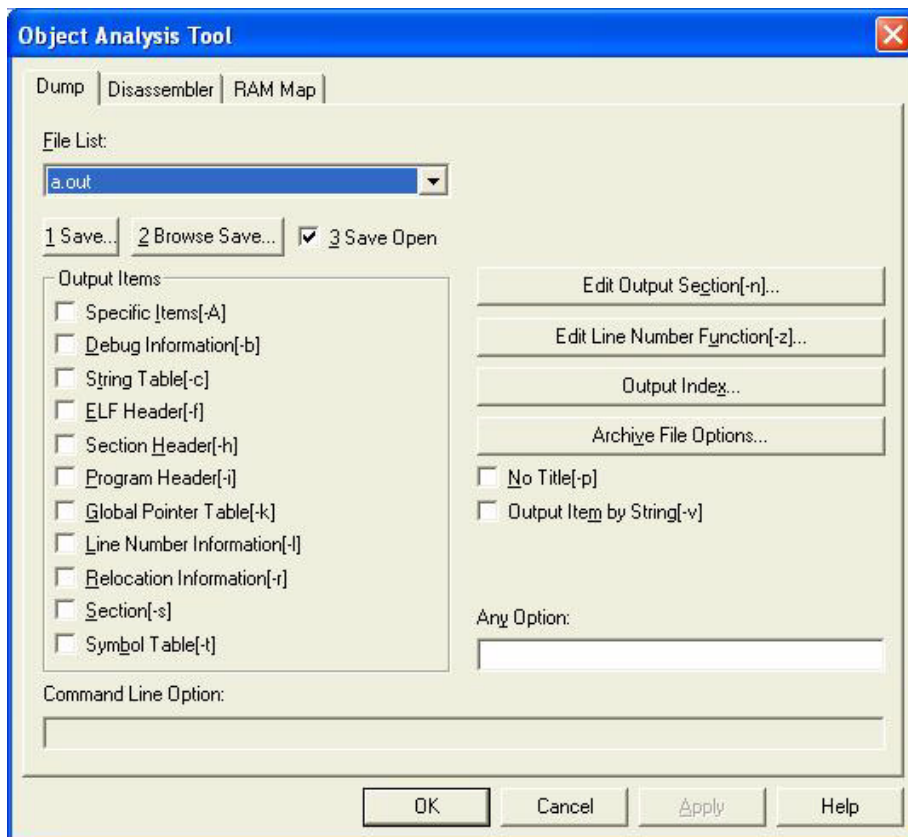

(1) File List

Object files for building in the project are displayed in the drop-down list. (Paths are not displayed in the list.)
The following files are displayed in the list.

- ROMization processor output files (only when ROMization is specified for projects in which executable object files are built)
- Linker output files (only for projects in which executable object files are built)
- Archiver output files (only for projects that output libraries)
- Compiler output files
- Assembler output files

Open the [Save As] dialog box with the [1 Save...] button and save the dump result of the object file specified in "File List". By default, it is saved as "object-file-name.dmp" in the same folder as the object file specified in "File List".

Also, with the [2 Browse Save...] button, the dump result can be saved by specifying the object file . In this case, the [Open] dialog box is opened, so specify the object file. By default, folders specified in previous [Open] dialog boxes or project folders are displayed.

When an object file is specified in the [Open] dialog box, the dump result for the specified object file is saved in the same way as clicking the [1 Save...] button.

(2) 3 Save Open

After saving the dump result with the [1 Save...] or [2 Browse Save...] button, this specifies whether or not to open the file which was saved with the editor set in PM+. It is selected by default.

(3) Output Items

Select items to be output as dump results using the check boxes.

(a) Specific Items[-A]

This outputs particular items specified with the -A option.

Selecting the box works the same as specifying with the -A option.

(b) Debug Information[-b]

This outputs debug information specified with the -b option.

Selecting the box works the same as specifying with the -b option.

This check box is unavailable when the -A option is specified.

(c) String Table[-c]

This outputs the string table specified with the -c option.

Selecting the box works the same as specifying with the -c option.

This check box is unavailable when the -A option is specified.

(d) ELF Header[-f]

This outputs the ELF header specified with the -f option.

Selecting the box works the same as specifying with the -f option.

This check box is unavailable when the -A option is specified.

(e) Section Header[-h]

This outputs the section header specified with the -h option.

Selecting the box works the same as specifying with the -h option.

This check box is unavailable when the -A option is specified.

(f) Program Header[-i]

This outputs the program header specified with the -i option.

Selecting the box works the same as specifying with the -i option.

This check box is unavailable when the -A option is specified.

(g) Global Pointer Table[-k]

This outputs the global pointer table specified with the -k option.

Selecting the box works the same as specifying with the -k option.

This check box is unavailable when the -A option is specified.

(h) Line Number Information[-l]

This outputs line number information specified with the -l option.

Selecting the box works the same as specifying with the -l option.

This check box is unavailable when the -A option is specified.

(i) Relocation Information[-r]

This outputs relocation information specified with the -r option.

Selecting the box works the same as specifying with the -r option.

This check box is unavailable when the -A option is specified.

(j) Section[-s]

This outputs the section specified with the -s option.

Selecting the box works the same as specifying with the -s option.

This check box is unavailable when the -A option is specified.

(k) Symbol Table[-t]

This outputs the symbol table specified with the -t option.

Selecting the box works the same as specifying with the -t option.

This check box is unavailable when the -A option is specified.

(4) No Title[-p]

This specifies whether or not to suppress output of the title specified with the -p option.

Selecting the box works the same as specifying with the -p option.

(5) Output Item by String[-v]

This specifies whether or not to output some items specified with the -v option as character strings.

Selecting the box works the same as specifying with the -v option.

(6) Any Option

This specifies options that cannot be set in the "dump850 command options" described before. Describe it into this edit box displays in the same format as described in the command line.

In addition, since all dump850 command-related options can be specified in this dialog box, it is not necessary to use any other options.

(7) Command Line Option

Options specified in the dialog box are displayed.

Since this area is for reference purposes, it cannot be written to.

[Buttons]

- (a) [Edit Output Section[-n]...] button
This opens the [\[Edit Option\] dialog box](#) for editing the output section specified with the -n option.
- (b) [Edit Line Number Function[-z]...] button
This opens the [\[Edit Option\] dialog box](#) for editing functions that output line number information specified with the -n option.
- (c) [Output Index...] button
This opens the [\[Output Index\] dialog box](#) for performing settings related to the output index.
- (d) [Archive File Options...] button
This opens the [\[Archive File Options\] dialog box](#) for performing settings for archive files.

10.4.2 [Output Index] dialog box

A dialog box for performing settings related to the output index.

Specify the various indexes in edit boxes with decimal or hexadecimal values.

Figure 10 - 3 [Output Index] Dialog Box

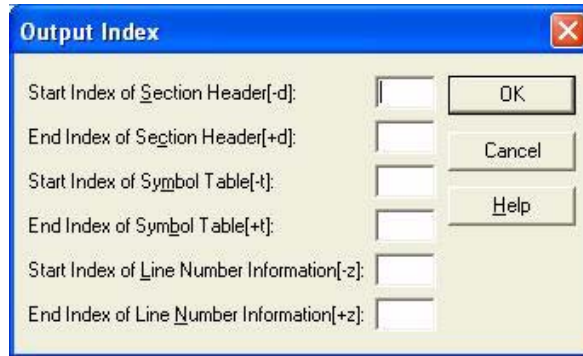

(1) Start Index of Section Header[-d]

This sets the section header start index specified with the -d option.

Specifying the value works the same as specifying with the -d option.

(2) End Index of Section Header[+d]

This sets the section header end index specified with the +d option.

Specifying the value works the same as specifying with the +d option.

(3) Start Index of Symbol Table[-t]

This sets the symbol table start index specified with the -t option.

Specifying the value works the same as specifying with the -t option.

(4) End Index of Symbol Table[+t]

This sets the symbol table end index specified with the +t option.

Specifying the value works the same as specifying with the +t option.

(5) Start Index of Line Number Information[-z]

This sets the line number information start index specified with the -z option.

Specifying the value works the same as specifying with the -z option.

(6) End Index of Line Number Information[+z]

This sets the line number information end index specified with the +z option.

Specifying the value works the same as specifying with the +z option.

10.4.3 [Archive File Options] dialog box

A dialog box for performing settings for archive files.

Figure 10 - 4 [Archive File Options] Dialog Box

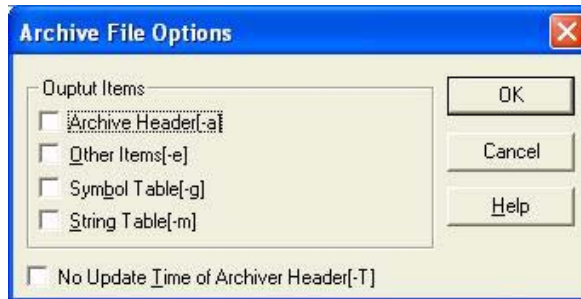

(1) Output Items

Select items to be output using the check boxes.

(a) Archive Header[-a]

This outputs the archive header specified with the -a option.

Selecting the box works the same as specifying with the -a option.

(b) Other Items[-e]

This outputs other archive file items specified with the -e option.

Selecting the box works the same as specifying with the -e option.

(c) Symbol Table[-g]

This outputs the archive file symbol table specified with the -g option.

Selecting the box works the same as specifying with the -g option.

This check box is unavailable when the -A option is specified.

(d) String Table[-m]

This outputs the archive file string table specified with the -m option.

Selecting the box works the same as specifying with the -m option.

This check box is unavailable when the -A option is specified.

(2) No Update Time of Archive Header[-T]

This suppresses output of the archive header updated date specified with the -T option.

Selecting the box works the same as specifying with the -T option.

10.5 Dump List

This section describes the display format of the dump850 command.

10.5.1 Dump list display contents

(1) Archive header

Display the contents of the archive header.

ARCHIVE HEADER					
Date (a)	Uid (b)	Gid (c)	Mode (d)	Size (e)	Member Name (f)
0x3158DE73	0	0	0100664	0x2B8	atof.o

- (a) Member updatedate
- (b) User ID
- (c) Group ID
- (d) File permission
- (e) Total number of bytes for members
- (f) Member name

(2) Archive symbol table

Display the contents of the archive symbol table.

ARCHIVE SYMBOL TABLE	
Offset (a)	Name (b)
0x1f3c	_abs

- (a) Offset in file to member including symbol
- (b) Symbol name

(3) Archive string table

Display the contents of the archive string table.

ARCHIVE STRING TABLE	
Offset (a)	Name (b)
0x1100	foo.o

- (a) Offset
- (b) Member name

(4) ELF header

Display the contents of the ELF header.

ELF HEADER				
Class (a)	Data (b)	Type (c)	Machine (d)	Version (e)
Entry (f)	Phoff (g)	Shoff (h)	Flags (i)	Ehsize (j)
Phentsize (k)	Phnum (l)	Shentsz (m)	Shnum (n)	Shstrndx (o)
1	1	1	070377	1
0x0	0x0	0x2A4	0x84	0x34
0x20	0	0x28	6	5

- (a) Class
- (b) Byte order
- (c) Type
- (d) Processor
- (e) Version number
- (f) Entry point address
- (g) Offset in file of program header table
- (h) Number of entries in section header table
- (i) Flag
- (j) Size of ELF header
- (k) Entry size of program header table
- (l) Number of entries in program header table
- (m) Entry size of section header table
- (n) Number of entries in section header table
- (o) Section header table index of string table containing section name

(5) Program header table

Display the contents of the program header table.

PROGRAM HEADER				
No. (a)	Type (b)	Offset (c)	Vaddr (d)	Paddr (e)
	Filesz (f)	Memsz (g)	Flags (h)	Align (i)
1.	0	0x0	0x0	0x0
	0x0	0x0	0x0	0x0

- (a) Index
- (b) Segment type
- (c) Offset in file
- (d) Virtual address
- (e) Physical address
- (f) File size
- (g) Memory size
- (h) Segment attribute
- (i) Alignment condition

(6) Section header table

Display the contents of the section header table.

SECTION HEADER						
No. (a)	Type (b)	Flags (c)	Addr (d)	Offset (e)	Size (f)	Name (g)
	Link (h)	Info (i)	Adralgn (j)	Entsize (k)		
1.	0x1	0x6	0x0	0x1	0x7556	.text
	0x0	0x0	0x4	0x0		

- (a) Index
- (b) Section type
- (c) Section attribute
- (d) Start address
- (e) Offset in file
- (f) Size
- (g) Section name
- (h) Section header table index link
- (i) Information
- (j) Alignment condition
- (k) Size of entry

(7) String table

Display the contents of the string table.

STRING TABLE INFORMATION	
Index (a)	String (b)
0x1	.text

- (a) Index
- (b) Character string

(8) Symbol table

Display the contents of the symbol table.

SYMBOL TABLE INFORMATION							
No.	Value	Size	Bind	Type	Other	Shndx	Name
1.	0x0	0x0	0	3	0	0x1	.text
(a)	(b)	(c)	(d)	(e)	(f)	(g)	(h)

- (a) Index
- (b) Value
- (c) Size
- (d) Binding class
- (e) Type
- (f) Other
- (g) Section header table index
- (h) Symbol name

(9) Relocation information

Display the contents of the relocation information (array of relocation entries).

SYMBOL TABLE INFORMATION			
Offset	Sym	Type	Addend
0x20	6	0x23	0x0
(a)	(b)	(c)	(d)

- (a) Offset
- (b) Symbol table index
- (c) Relocation type
- (d) Added constant

(10) Register mode information

Display the contents of the register mode information.

REGISTER MODE INFORMATION		
SymIdx	TmpReg	ParReg
0x1	0x5	0x5
(a)	(b)	(c)

- (a) Symbol table index
- (b) Number of working registers
- (c) Number of registers for register variables

(11) Global pointer table

Display the contents of the global pointer table.

GPTAB INFORMATION	
Gnum	Gsize
0x4	0xc
(a)	(b)

- (a) Size of *num/data* of *-Gnum*
- (b) Size when aligned by 0/word

(12) Line number information

Display the contents of the line number information.

LINE NUMBER INFORMATION									
Bfunc	Maddr	Daddr	Pad	Function Name	Num	Snum	Offset	Flags	
0x0	0xA2	0xE28	0x0	_main	0x5	0x0	0x0	0x1	
(a)	(b)	(c)	(d)	(e)	(f)	(g)	(h)	(i)	

- (a) start of subsection
- (b) Address of function
- (c) Address of debug information
- (d) Padding
- (e) Function name
- (f) Line number
- (g) Position of statement
- (h) Offset
- (i) Flag

(13) Debug information

Display the contents of the debug information.

DEBUG INFORMATION		
Tag	Attr	Aux
0x0016		
size	0x00000026	
	0x000c	0x00000E1C
(a)	(b)	(c)

- (a) Tag
- (b) Attribute
- (c) Auxiliary information

(14) PROGBITS data

PROGBITS DATA in HEX
0x00000000 : 40 0E 00 00 21 2E 00 00 ...

Display in hexadecimal numbers the raw data contents of the section having section type PROGBITS.

10.5.2 Element values and meanings

When the `-v` option has been specified, the following information indicates that character strings are used instead of numerical values to indicate the meanings of the values for some elements.

- ELF header
- Program header table
- Section header table
- Symbol table
- Relocation information
- Debug information

The following tables list values^{Note}, the display when `-v` is specified, and the meanings of the elements that are displayed as character strings when `-v` has been specified.

Note The value is displayed using the number base output by the `dump850` command.

(1) "Flags" in ELF headers

Value	Display When <code>-v</code> Is Specified	Meaning
0x1	L_____	.vline section exists
0x2	_D_____	.vdebug section exists
0x4	__P_____	Object is a PIC (Position Independent Code) object
0x10	___R_____	Register mode is 22-register mode or 26-register mode
0x20	____d_____	Different register modes are mixed
0x40	_____r_____	Object is output by <code>romp850</code>
0x80	_____N_____	Default function call specification (call does not use old specification).
0x100	_____M_____	Uses mask register function.
0x200	_____U_____	The prologue and epilogue runtime libraries use the <code>callt</code> instruction.
0x400	_____S_____	The prologue and epilogue runtime libraries use the CTBP for <code>callt</code> instruction.

(2) "Type" in program header table

Value	Display When <code>-v</code> Is Specified	Meaning
1	Load	Segment is loaded into memory
4	Note	Segment, including auxiliary information

(3) "Type" in section header table

Value	Display When -v Is Specified	Meaning
0x1	Progbits	Section that corresponds to an entity that contains an actual value in an object file (machine language instruction and data with default value)
0x2	Symtab	Symbol table
0x3	Strtab	String table
0x4	Rela	Relocation information
0x8	Nobits	Section that corresponds to an entity that does not contain an actual value in an object file (data without default value)
0x9	Rel	Relocation information
0x70000000	Gptab	Global pointer table (in which the first entry contains a num of - Gnum specified for ca850 or as, and the 0th, 2nd, and subsequent entries indicate the size when aligned with data size and word)
0x70000001	Regmode	Section that exists in a relocatable object file created using the register mode function (Information concerning the number of registers used internally by the CA850 is stored)

(4) "Bind" in symbol table

Value	Display When -v Is Specified	Meaning
0	Local	Symbol that is not used to resolve external reference
1	Global	Symbol that is used to resolve external reference

(5) "Type" in symbol table

Value	Display When -v Is Specified	Meaning
1	Object	Ordinary object (label)
2	Func	Function name
3	Section	Section
4	File	Ordinary file name
13	Devfile	Device file name

(6) "Shndx" in symbol table

Value	Display When -v Is Specified	Meaning
0x0	Undef	Undefined symbol
0xFF00	GpCommon	Undefined external symbol that is referenced by global pointer (gp) and 16-bit displacement
0xFFF1	Abs	Symbol indicating constant
0xFFF2	Common	Undefined external symbol that is referenced by global pointer (gp) and 32-bit displacement

For further description of object file formats, refer to "[APPENDIX A FORMAT OF OBJECT FILE](#)".

CHAPTER 11 DISASSEMBLER

This chapter describes the outline, operation, and display format of the disassembler (dis850).

11.1 Disassembler

A disassembler is a utility that converts the program codes of an object file that has been compiled or assembled or an archive file created with the ar850 into assembly-language codes for output. This utility is used to verify the codes of an object file.

The disassembler of the C compiler package is "dis850".

Figure 11 - 1 Operation Flow of dis850 Command

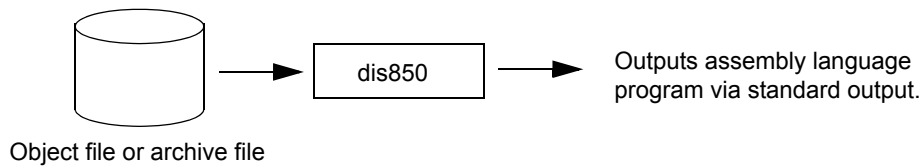

11.2 Operation Method

This section describes how to use the dis850 command.

11.2.1 Command input method

Enter the following from the command prompt.

```
dis850 [option] ... file1 [file2] ...  
[ ] : Can be omitted  
... : More than one input file can be specified.
```

11.2.2 Method using PM+

The [\[Object Analysis Tool\] dialog box](#) that is used to activate the disassembler can be displayed via the following methods once a project has been established under PM+.

- Select [Tool] - [Startup Object Analysis Tool...], then click the [\[Disassembler\]](#) tab

Since the disassembler is activated once per project, there are no file-specific settings.

11.3 Types and Features of Options

The dis850 options are shown below.

If no option is specified, it is assumed that the `-o` option has been specified.

-A

Specifying this option is the same as specifying the option `-aoptr`.

-F *devpath*

This option searches folder `devpath` for the device file. If this option is omitted, the standard folder is searched.

-V

dis850 handles the folder at the `..\dev` position from the dis850's installation folder as the standard folder of the device file.

-a

This option displays addresses.

-c

This option displays code (assembler instruction, data).

-e *address*

This option specifies an end address. The *address* is specified as a decimal number or as a hexadecimal number starting with `0x`. If this option is omitted, it is assumed that `0xffffffff` has been specified.

-l *size*

This option specifies the display size. *size* is specified as a decimal number or as a hexadecimal number starting with `0x`. If this option is omitted, it is assumed that `0xffffffff` has been specified.

-m

This option displays the assembly language source's format. If this option is omitted, it is displayed with a symbol offset, etc.

-o

This option displays the offset from symbols. If this option is omitted, symbols are displayed unless the `-a` option or the `-m` option has been specified.

-p

This option displays code that has been arranged according to the processor's instruction format. However, the `-c` option takes priority if it has been specified.

-r

This option displays registers `r0`, `r2`, `r3`, `r4`, `r5`, `r30`, and `r31` as `zero`, `hp`, `sp`, `gp`, `tp`, `ep`, and `lp`. If this option is omitted, all registers are displayed in `rnum` format, in which `num` is a value from 0 to 31.

-s *address*

This option specifies a start address. The *address* is specified as a decimal number or as a hexadecimal number starting with 0x. If this option is omitted, it is assumed that 0x0 has been specified.

-t

This option displays a title indicating the displayed contents.

-v

This option displays comments, etc.

@*cfile*

This option handles *cfile* as a command file. A command file specifies an option and a file name for a command not as arguments on the command line but by describing them in a file. On Windows, the length of a character string specified as an option of a command is limited. If many options are set and some of the options cannot be recognized, create a command file and specify this option.

For details of the command file, refer to "[3.7.2 Command file](#)".

11.4 Settings Made via PM+

This section describes dialog boxes that are used to set the command options of the dis850 for the target project's source file.

11.4.1 [Object Analysis Tool] dialog box

At the upper part of this dialog box, the following three tabs are displayed.

The contents of this dialog box depend on selecting the following tab.

Table 11 - 1 [Object Analysis Tool] Dialog Box (dis850)

Tab	Description
[Dump]	Setting of options related to dump command
[Disassembler]	Setting of options related to disassembler
[RAM map]	Setting of options related to RAM map

[Disassembler]

For the disassembler activation dialog box, set the project settings in the PM+, then select the [Disassembler] tab in the dialog opened by selecting [Tool] - [Startup Object Analysis Tool...].

Figure 11 - 2 [Object Analysis Tool] Dialog Box ([Disassembler] Tab)

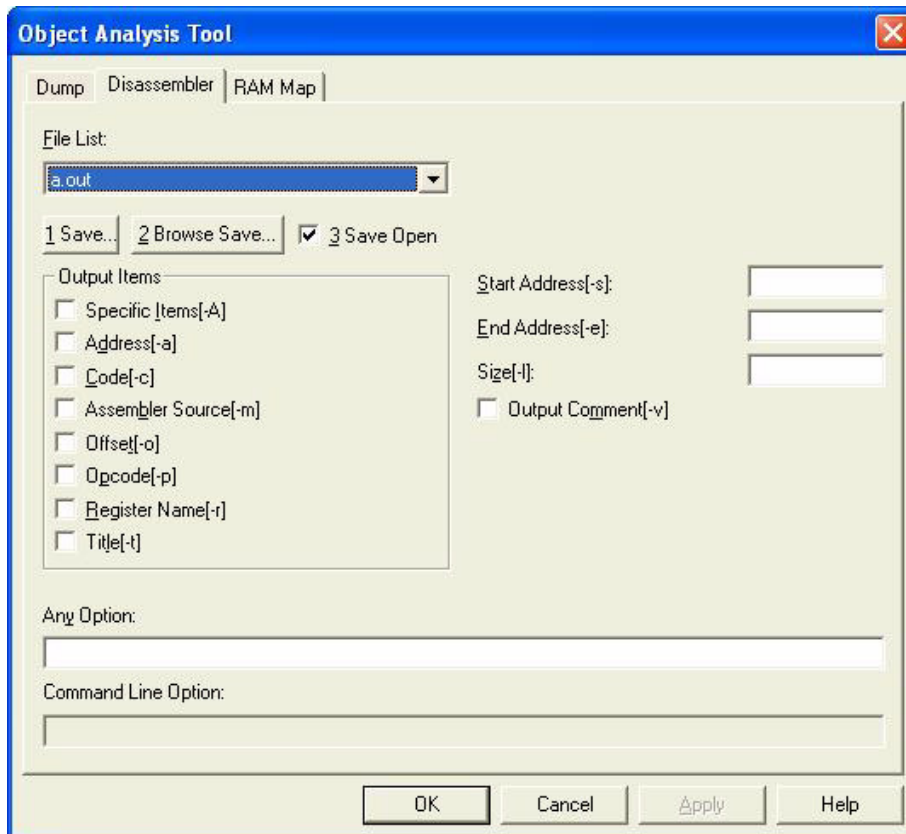

(1) File List

Object files for building in the project are displayed in the drop-down list. (Paths are not displayed in the list.)
The following files are displayed in the list.

- ROMization processor output files (only when ROMization is specified for projects in which executable object files are built)
- Linker output files (only for projects in which executable object files are built)
- Archiver output files (only for projects that output libraries)
- Compiler output files
- Assembler output files

Open the [Save As] dialog box with the [a Save...] button and save the disassemble result of the object file specified in "File List". By default, it is saved as "object-file-name.dis" in the same folder as the object file specified in "File List".

Also, with the [2 Browse Save...] button, the disassemble result can be saved by specifying the object file. In this case, the [Open] dialog box is opened, so specify the object file. By default, folders specified in previous [Open] dialog boxes or project folders are displayed.

When an object file is specified in the [Open] dialog box, the disassemble result for the specified object file is saved in the same way as clicking the [1 Save...] button.

(2) 3 Save Open

After saving the disassemble result with the [1 Save...] or [2 Browse Save...] button, this specifies whether or not to open the file which was saved with the editor set in PM+. It is selected by default.

(3) Output Items

Select items to be output as disassemble results using the check boxes.

(a) Specific Items[-A]

This outputs particular items specified with the -A option.

Selecting the box works the same as specifying with the -A option.

(b) Address[-a]

This outputs the address specified with the -a option.

Selecting the box works the same as specifying with the -a option.

This check box is unavailable when the -A option is specified.

(c) Code[-c]

This outputs the code specified with the -c option.

Selecting the box works the same as specifying with the -c option.

(d) Assembler Source[-m]

This outputs the assembler source specified with the -m option.

Selecting the box works the same as specifying with the -m option.

(e) Offset[-o]

This outputs the offset specified with the -o option.

Selecting the box works the same as specifying with the -o option.

This check box is unavailable when the -A option is specified.

(f) Opcode[-p]

This outputs the opcode specified with the -p option.

Selecting the box works the same as specifying with the -p option.

This check box is unavailable when the -A option is specified.

(g) Register Name[-r]

This outputs the register name specified with the -r option.

Selecting the box works the same as specifying with the -r option.

This check box is unavailable when the -A option is specified.

(h) Title[-t]

This outputs the title specified with the -t option.

Selecting the box works the same as specifying with the -t option.

This check box is unavailable when the -A option is specified.

(4) Start Address[-s]

This sets the start address specified with the -s option.

Specify the edit box with a decimal or hexadecimal value.

Specifying the value works the same as specifying with the -s option.

(5) End Address[-e]

This sets the end address specified with the -e option.

Specify the edit box with a decimal or hexadecimal value.

Specifying the value works the same as specifying with the -e option.

(6) Size[-l]

This sets the size of the output range specified with the -l option.

Specify the edit box with a decimal or hexadecimal value.

Specifying the value works the same as specifying with the -l option.

(7) Output Comment[-v]

This specifies whether or not to output comments specified with the -v option.

Selecting the box works the same as specifying with the -v option.

(8) Any Option

This specifies options that cannot be set in the "dis850 command options" described before. This edit box displays in the same format as the command line.

In addition, since all dis850 command-related options can be specified in this dialog box, it is not necessary to use any other options.

(9) Command Line Option

Options specified in the dialog box are displayed in the command line options.

Since this area is for reference purposes, it cannot be written to.

11.5 Cautions

- (1) If labels for the same address exist in the object file, the latter label in the symbol table takes priority.
- (2) If the program starts from address 0 and if output of the symbol at address 0 is required during output for an object that does not have a symbol indicating address 0, "__dummy" may be output as the symbol of address 0.

11.6 Output Format

The following are examples of dis850 output.

```
> dis850 -A a.out

      Address      Offset      Opcode
      _main:
0x00000000 : 0x00000000 : 45D5      br      _main + 0x8a
0x00000002 : 0x00000002 : D800      mov     zero, r27
0x00000004 : 0x00000004 : E6230000  movea  0, sp, r28
0x00000008 : 0x00000008 : 301C      mov     r28, r6
0x0000000A : 0x0000000A : FF800176  jarl   _getToken[pc], lp
0x0000000E : 0x0000000E : 580A      mov     r10, r11
0x00000010 : 0x00000010 : 5A7F      cmp    -0x1, r11
0x00000012 : 0x00000012 : 1D92      bz     _main + 0x44
0x00000014 : 0x00000014 : EE2003E8  movea  0x3e8, zero, r29
0x00000018 : 0x00000018 : D9FD      cmp    r29, r27
0x0000001A : 0x0000001A : 15DE      bge   _main + 0x44
0x0000001C : 0x0000001C : 301C      mov     r28, r6
0x0000001E : 0x0000001E : FF800000  jarl   0[pc], lp
0x00000022 : 0x00000022 : 580A      mov     r10, r11
0x00000024 : 0x00000024 : 501B      mov     r27, r10
0x00000026 : 0x00000026 : 52C2      shl    0x2, r10
0x00000028 : 0x00000028 : 66230020  movea  0x20, sp, r12
0x0000002C : 0x0000002C : 61CA      add    r10, r12
0x0000002E : 0x0000002E : 5F6C0001  st.w   r11, 0[r12]
0x00000032 : 0x00000032 : DA41      add    0x1, r27
0x00000034 : 0x00000034 : 301C      mov     r28, r6
0x00000036 : 0x00000036 : FF80014A  jarl   _getToken[pc], lp
0x0000003A : 0x0000003A : 580A      mov     r10, r11
0x0000003C : 0x0000003C : 5A7F      cmp    -0x1, r11
0x0000003E : 0x0000003E : 05B2      bz     _main + 0x44
...

```

Among the information in the file a.out, the dis850 displays addresses, offsets, codes (according to instruction format), and titles, along with assembly language instructions. Registers are displayed using aliases.

CHAPTER 12 CROSS REFERENCE TOOL

This chapter presents an overview of the cross reference tool (CXREF) and describes its operation, and output file format.

12.1 Cross Reference Tool

The cross reference tool "CXREF" is a tool that checks identifier references and definition locations based on the C language source file. The target identifiers, which are functions and variables (other than auto variables), also identify their storage class.

Cross reference information and tag jump information are output as the detection results. The analysis is performed for individual functions, and a call tree, function metrics, and call database can also be output.

In cross reference tool processing, a "reference" means that the identifier appears within an expression and a "definition" means that the identifier appears within a declaration statement. The cross reference tool handles an identifier for which it cannot determine whether it appears in an expression or a declaration statement as "unknown."

Call trees, function metrics, or call databases that are output by the cross reference tool have the following features.

- They do not depend on the target and the ca850 optimization.
- Standard output can be used by specifying an option.

Figure 12 - 1 Flow of Operation in cxref

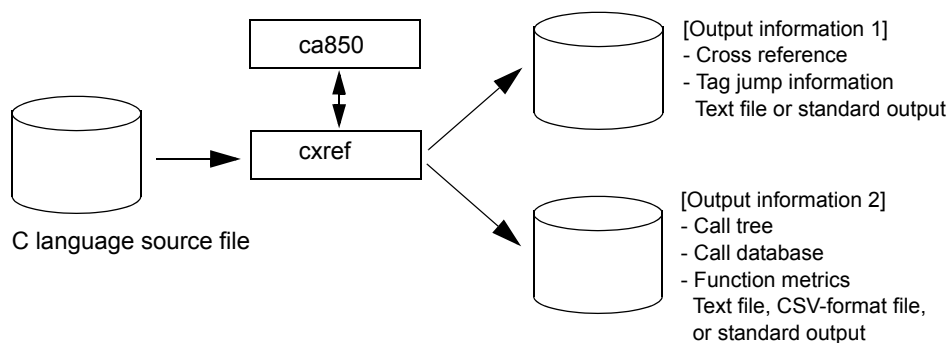

12.2 Input/Output

12.2.1 Input file

The CXREF input file is a C language source file. If the `-cpp850` option is specified when the cross reference tool is started, the cross reference tool processing is performed after the specified C language source file has passed through the preprocessor.

- (1) A prerequisite for CXREF processing is that the C language source file to be input contains no syntax errors. Confirm that compilation has been executed for the C language source file and that no syntax error was found.
- (2) The character set is assumed to be Shift JIS.
- (3) The cross reference tool performs its analysis by simply ignoring preprocessor instructions included in the C language source file, without performing any error handling for these instructions. Therefore, if a C language source file does not contain any of the following items, it can be processed directly without specifying the `-cpp850` option, even if the file has not passed through the `ca850`. This is effective when ignoring a header file, when subjecting false condition blocks to analysis, and when targeting macro names for cross reference.
 - Condition block in which braces `{ }` are not balanced
 - Macro created for a control structure
 - Macro created for a declaration statement
- (4) The input file can contain line number information and comment information.

12.2.2 Output information

The following information is output by cxref.

(1) [Cross reference](#)

The cross reference outputs cross reference information for variables and functions that are used within the file, for each file.

(2) [Tag information](#)

The tag information outputs the definition file name and line number information (tag jump information) for variables and functions.

(3) [Call tree](#)

The call tree outputs which functions are called by certain functions in tree format.

(4) [Function metrics](#)

The function metrics output information about the function such as the "number of lines" and "call frequency."

(5) [Call database](#)

The call database outputs the functions called by a given function and the number of times each function is called by that function.

For details about each kind of information, refer to "[12.6 Output Files](#)" and following.

12.3 Operation Method

This section explains operations for cxref.

12.3.1 Command input method

Enter the following from the command prompt (Windows).

```
cxref [option] ... [file] ...  
[ ] : Can be omitted.  
... : Pattern in preceding [ ] can be repeated.
```

12.3.2 Method using PM+

The [\[Static performance analyzer\] dialog box](#) that is used to set the cross reference options can be displayed via the following methods once a project has been established under PM+.

- Select [Tool] - [Static performance analyzer], then click the [\[Cross reference\]](#) tab

Since the cross reference tool is activated once per project, there are no file-specific settings.

12.4 Types and Features of Options

The cxref options are shown below.

These are presented separately for each kind of output information.

12.4.1 Common options

The cxref common options are shown below.

-v

This option outputs the version number of cxref and then terminates processing.

-all

This option outputs all information to a text-format file and CSV-format file.

This option has the same result as when "-x -t -c -cc -m -mc -b -bc" is specified.

-cpp850

This option processes the C language source file after it is passed through the ca850(preprocessor).

This option and all subsequent options are passed as the ca850 options. Therefore, this option must be specified as the last cross reference tool option.

Setting -c option that works to include comments of the source programs with the preprocessor is recommended so that line numbers are output correctly.

Example

```
> cxref -t -cpp850 -cpu 3201 -DDEBUG -I..\myinc main.c sub.c
```

The above operations are the same as the following operations.

```
> ca850 -cpu 3201 -E -DDEBUG -I..\myinc main.c > main.i
> ca850 -cpu 3201 -E -DDEBUG -I..\myinc sub.c > sub.i
> cxref -t main.i sub.i
```

-dident

This option specifies an identifier that is handled as a type name.

-d=file

This option specifies the name of a file in which an identifier that is handled as a type name is defined.

-file=file

This option specifies the name of a *file* in which the following information is defined.

- (1) File name that is not to be displayed in execution results
- (2) Identifier name that is not to be displayed in execution results
- (3) Identifier name that is to be handled as a type name

When -file=*file* and -ni are specified at the same time, the contents of "NoIncludeFile" in file of the previously specified -file=*file* option are invalid.

- File format specified as -ni/-i/-d/file options

The -ni/-i/-d options read the corresponding section information, and the -file option reads all the section information.

The three sections below can be described.

- [NoIncludeFile section](#)

- [DefinitionType section](#)

- IgnoreIdent section

If a line begins with //, the line is regarded as a comment.

(1) NoIncludeFile section

This section specifies information that is not displayed as an analysis result, for each file. This section mainly describes Include files. A file name specified in this section has the same effect as the same file name specified after the -ni option.

Describe one file name on one line. Wildcard characters can be used.

Example

```
[NoIncludeFile]
// All the * .h files
*.h
// common definition file
common.def
```

(2) DefinitionType section

This section specifies an identifier that is handled as a type name. A file name specified in this section has the same effect as the same file name specified after the -d option. Describe one identifier in one line.

Example

```
[DefinitionType]
// 1-byte type
BYTE
UBYTE
// 2-byte type
WORD
UWORD
```

(3) IgnoreIdent section

This section specifies information that is not displayed as an analysis result, for each identifier. A file name specified in this section has the same effect as the same file name specified after the -i option.

Describe one identifier in one line.

Example

```
[IgnoreIdent]
// Common area temporarily used in each process
tmp
buf
work
```

-h

-help

This option outputs an explanation of the options and then terminates processing.

-iident

This option specifies an identifier that is not to be displayed in the execution results.

-i=file

This option specifies the name of the *file* in which an identifier that is not to be displayed in the execution results is defined.

-ni

This option causes include file information not to be displayed.

-ni file

This option specifies a *file* name that is not to be displayed in the execution results. Wild cards can be used in *file*.

?	One arbitrary character
*	The arbitrary character sequences of zero or more characters

Example

r	File name that includes 'r'
e??	File name that includes 'e' and two or more subsequent characters
w?*.h	File name composed of two or more characters, which starts with 'w' and ends with '.h'

-ni=file

This option specifies the name of the *file* in which file names that are not to be displayed in the execution results are defined.

-o path

This option specifies the output file *path*.

If this option is omitted, the file is output to the current path.

@cfile

This option handles *cfile* as a command file. A command file specifies an option and a file name for a command not as arguments on the command line but by describing them in a file. On Windows, the length of a character string specified as an option of a command is limited. If many options are set and some of the options cannot be recognized, create a command file and specify this option.

For details of the command file, refer to "[3.7.2 Command file](#)".

12.4.2 Cross reference

The cxref cross reference options are shown below.

-x [=file]

This option outputs the cross reference in text format to the specified *file*. If [=file] is omitted, cxref is assumed for the file name.

-xstd

This option outputs the cross reference to standard output (default).

12.4.3 Tag information

The cxref tag information options are shown below.

-t [=file]

This option outputs tag information in text format to the specified *file*. If [=file] is omitted, ctags is assumed for the file name.

-tstd

This option outputs tag information to standard output.

12.4.4 Call tree

The cxref Call tree options are shown below.

-c [=file]

This option outputs the call tree in text format to the specified *file*.

If [=file] is omitted, ccalltre.lst is assumed for the file name.

-cc [=file]

This option outputs the call tree in CSV format to the specified *file*.

If [=file] is omitted, ccalltre.csv is assumed for the file name.

-call [=file]

This option outputs the call tree in text format and CSV format to the specified files.

The file names are file.lst and file.csv. If an extension is appended to the specification for file, that extension is ignored.

If [=file] is omitted, ccalltre.lst and ccalltre.csv are assumed for the file names.

-cenum

This option specifies the method of omitting output. Any of the following can be specified for num.

1	Output all information
2	Omit output for call trees at the same level
3	Omit output once the information has been output

If this option is omitted, -ce3 is assumed.

-cfstring

This option specifies for string the function name for which the call tree is to be output.

-cf=file

This option specifies the text *file*, which contains specifications of the function names for which a call tree is to be output.

-clnum

This option specifies the output level. Any number from 1 to 255 can be specified for num. If this option is omitted, 255 is assumed.

-cp

This option includes the arguments and return value in the output.

-cr

This option includes reference information in the output.

-cs

This option includes the source file name and description starting line in the output.

-cstd

This option outputs the text-format call tree to standard output.

-ct

This option outputs only the first tree.

12.4.5 Function metrics

The cxref function metrics options are shown below.

-m [=file]

This option outputs the function metrics in text format to the specified *file*.

If [=file] is omitted, cmeasure.lst is assumed for the file name.

-mc [=file]

This option outputs the function metrics in CSV format to the specified *file*. If [=file] is omitted, cmeasure.csv is assumed for the file name.

-m_{all} [=file]

This option outputs the function metrics in text format and CSV format to the specified *files*.

The file names are file.lst and file.csv. If an extension is appended to the specification for file, that extension is ignored.

If [=file] is omitted, cmeasure.lst and cmeasure.csv are assumed for the file names.

-ms [+ | -] num

This option specifies the output order. Any of the following can be specified for *num*.

1	Output the information sorted in alphabetical order of the function names.
2	Output the information sorted in alphabetical order of the file names and function names
3	Output the information without sorting.

If "+" is specified, the information is output in ascending order. If "-" is specified, the information is output in descending order. If this option is omitted, the information is output without sorting, in the order that the functions appeared.

-mstd

This option outputs the text-format function metrics to standard output.

12.4.6 Call database

The cxref call database options are shown below.

-b [=file]

This option outputs the call database in text format to the specified file.

If [=file] is omitted, cprofile.dat is assumed for the file name.

-bc [=file]

This option outputs the call database in CSV format to the specified file. If [=file] is omitted, cprofile.csv is assumed for the file name.

-ball [=file]

This option outputs the call database in text format and CSV format to the specified files.

The file names are file.lst and file.csv. If an extension is appended to the specification for file, that extension is ignored.

If [=file] is omitted, cprofile.dat and cprofile.csv are assumed for the file names.

-bstd

This option outputs the text-format call database to standard output.

12.5 Settings Made via PM+

This section describes the dialog box that is used to set command options of the cxref for a file of the targeted project.

12.5.1 [Static performance analyzer] dialog box

At the upper part of this dialog box, the following two tabs are displayed.

The contents of this dialog box depend on selecting the following tab.

Table 12 - 1 [Static performance analyzer] Dialog Box (cxref)

Tab	Description
[Cross reference]	Setting of cross reference options
[RAM map]	Setting of RAM map options

[Cross reference]

This tab is used to set the "Cross reference".

Figure 12 - 2 [Static performance analyzer] Dialog Box (Cross reference)

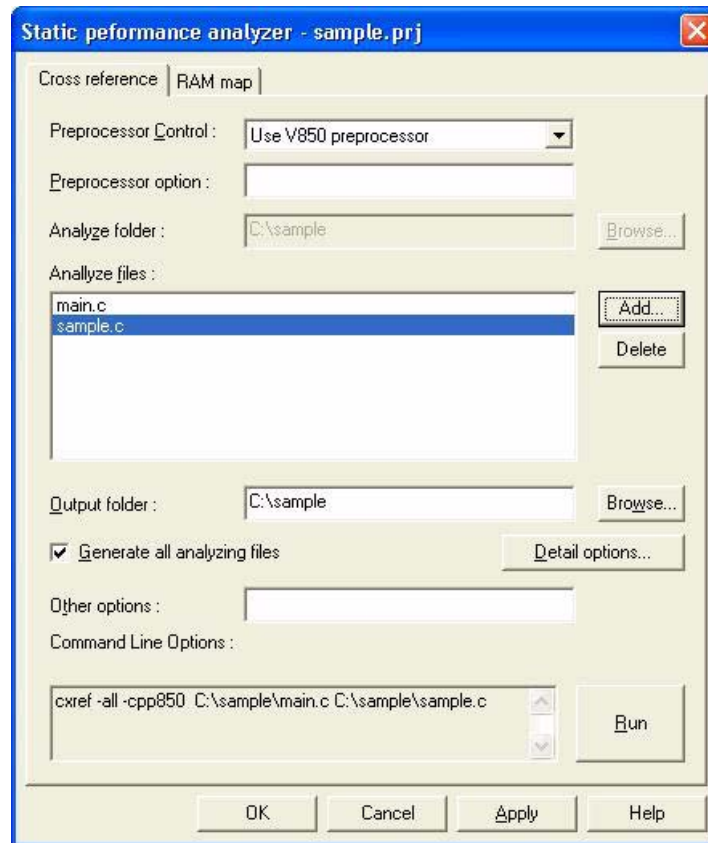

(1) Preprocessor Control

Select a preprocessor in the combo box.

The default assumption is as follows.

- If an option is saved, the specification of the saved preprocessor is displayed.
- If an option is not saved but there is information specified by a compiler option in the project file, "Use V850 preprocessor" is assumed.
- If an option is not saved and there is no information specified by a compiler option in the project file, "No use preprocessor" is assumed.

(2) Preprocessor option

Specify options of the preprocessor.

Setting -c option that works to include comments of the source programs with the preprocessor is recommended so that line numbers are output correctly.

(3) Analyze folder

Specify an analyze folder in the edit box.

The default assumption is as follows.

- If an option is saved, the saved analysis folder is used.
- If an option is not saved, the folder where the project file is placed is used.

(4) Analyze files

A list of analyze files is displayed in the list box.

The default assumption is as follows.

- If an option is saved, the saved file to be analyzed is used.
- If no option is saved, what is used is the C language source file specified in the project file corresponding to the source file registered in the project file.

Clicking the [Add...] button displays an additional file name. A file name cannot be directly input. Clicking the [Add...] button opens the [Set analyze file] dialog box where a file can be specified. The specified file is displayed in the list. If "Analyze folder" is blank, the path of the specified file is displayed in "Analyze folder".

In the [Set analyze file] dialog box, the default position is determined in the following sequence:

- (1) "Analyze folder" on this tab
- (2) "Output folder" on this tab
- (3) Path of "Analyze file" on the [RAM map] tab
- (4) Install folder

Clicking the Delete button deletes the file selected from the list.

This button can be selected only if a file is selected from the list.

(5) Output folder

Specify the analysis result output destination (folder) in the edit box.

The default assumption is as follows.

- If an option is saved, the saved analysis result output destination is assumed.
- If an option is not saved, the folder where the project file is placed is assumed.

This box is blank in the default condition. If the specified folder does not exist, clicking the [OK] or [Apply] button opens a folder creation dialog box, and clicking the [OK] button creates a folder.

Clicking the [Browse...] button opens the "Browse for Folder" dialog box where a folder to which the analysis result is to be output can be selected. The selected folder is displayed in "Output folder".

In the "Browse for Folder" dialog box, the default position is determined in the following sequence:

- (1) "Output folder" on this tab
- (2) "Analyze folder" on this tab
- (3) Path of "Analyze file" on the [RAM map] tab
- (4) Install folder

(6) Generate all analyzing files

If this is checked, the defaults of the options are set. It is checked in the default condition.

(7) Detail options

Clicking this button opens the [\[Cross reference Option\] dialog box](#) where the option of each function can be set.

(8) Other options

Options can be directly described in the edit box. This box is blank in the default condition.

(9) Command Line Options

A list of options is displayed. "cxref -all" is displayed in the default condition. Clicking the [Run] button starts analysis of the analyze file with the set option contents. The analysis command in install folder is started. If no analyze file is specified, a message box that indicates no analyze file is specified is opened. Depending on the result of analysis, a message box that indicates normal or abnormal termination is opened. The output message of the analysis command is output to file cxref.log in the folder at the analysis result output destination or that in the folder of the analysis folder.

12.5.2 [Cross reference Option] dialog box

This dialog box is displayed by clicking the "Detail options" button on the [Cross reference] tab in the [Static performance analyzer] dialog box.

At the upper part of this dialog box, the following six tabs are displayed.

The contents of this dialog box depend on selecting the following tab.

Table 12 - 2 [Cross reference Option] Dialog Box

Tab	Description
[Common option]	Setting of common options.
[Cross reference list]	Setting of the cross reference list.
[Tag information]	Setting of the tag information.
[Call graph]	Setting of the call graph.
[Function measure]	Setting of the function measure.
[Call database]	Setting of the call database.

[Common option]

This tab is used to set common options.

Figure 12 - 3 [Cross reference option] Dialog Box ([Common option] Tab)

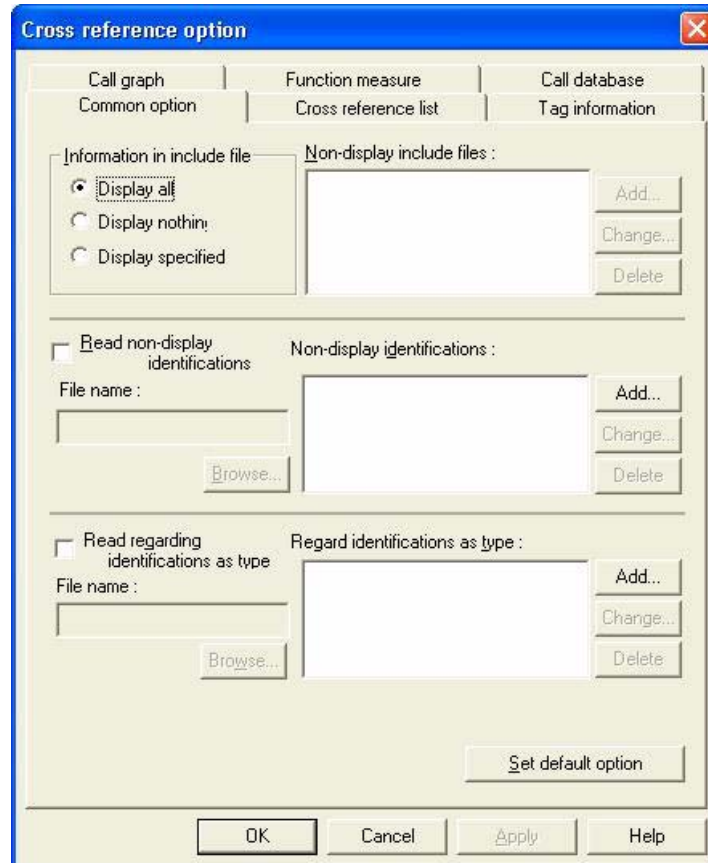

(1) Information in include file

Specify how the include file information is to be output to the execution result.

Display all	Displays all the information in the include file on the execution result (default).
Display nothing	Hides all the information in the include file.
Display specified	Makes "Non-display include files" and the [Add...] button selectable.

(2) Non-display include files

The include file name to be hidden is displayed.

A function name of 38 characters or more is displayed in the form of "first-18-characters...last-18-characters".

This can be selected if "Display specified" is selected for "Information in include file".

Clicking the [Add...] button opens the [Set analyze file] dialog box. If an include file is selected in this dialog box, it is added to the list.

In the [Set analyze file] dialog box, the default position is determined in the following sequence:

- (1) "Analyze folder" on the [Cross reference] tab
- (2) Path of "Analyze file" on the [RAM map] tab
- (3) Install folder

If an include file is selected from the list and the [Change...] button is clicked, the [Set analyze file] dialog box is opened, and the include file is changed into the one selected in the dialog box.

Clicking the [Delete] button deletes the include file selected from the list.

The [Change...] and [Delete] buttons can be selected only if an include file is specified in the list.

(3) Read non-display identifications

The name of the identifier whose information name is not to be output is displayed. By checking this check box and specifying a file name, the name of the identifier that is not displayed is read. "File name" is blank in the default condition.

When the [Apply] button at the lower part of the dialog box is selected, the name of the identifier in a selected file is displayed on the list of "Non-display identifications". If [Browse...] button is selected, the existing file name can be referenced on the [Browse for File] dialog box.

(4) Non-display identifications

The identifier name to be hidden is displayed.

A function name of 38 characters or more is displayed in the form of "first-18-characters...last-18-characters".

Clicking the [Add...] button opens the [Set analyze file] dialog box. If an identifier is selected in this dialog box, it is added to the list.

If an identifier is selected from the list and the [Change...] button is clicked, the [Set analyze file] dialog box is opened, and the identifier is changed into the one selected in the dialog box.

Clicking the [Delete] button deletes the identifier selected from the list.

The [Change...] and [Delete] buttons can be selected only if an identifier is specified in the list.

(5) Read regarding identifications as type

The identifier name that is treated as a type is displayed. By checking this check box and specifying a file name, the name of an identifier that is treated as a type is read. "File name" is blank in the default condition.

When the [Apply] button at the lower part of the dialog box is selected, the name of the identifier in the specified file is displayed on the list of "Regard identifications as type". If the [Browse...] button below is selected, the existing file name can be referenced on the [Browse for File] dialog box.

(6) Regard identifications as type

The identifier name that is treated as a type is displayed.

A function name of 38 characters or more is displayed in the form of "first-18-characters...last-18-characters".

Clicking the [Add...] button opens the [Set analyze file] dialog box. If an identifier file is selected in this dialog box, it is added to the list.

If an identifier is selected from the list and the [Change...] button is clicked, the [Set analyze file] dialog box is opened, and the identifier is changed into the one selected in the dialog box.

Clicking the Delete button deletes the identifier selected from the list.

The [Change...] and [Delete] buttons can be selected only if an identifier is specified in the list.

[Button]**(a) [Set default option] button**

This button returns the current setting of the dialog box to the default status.

[Cross reference list]

This tab is used to set the cross reference list.

Figure 12 - 4 [Cross reference option] Dialog Box ([Cross reference list] Tab)

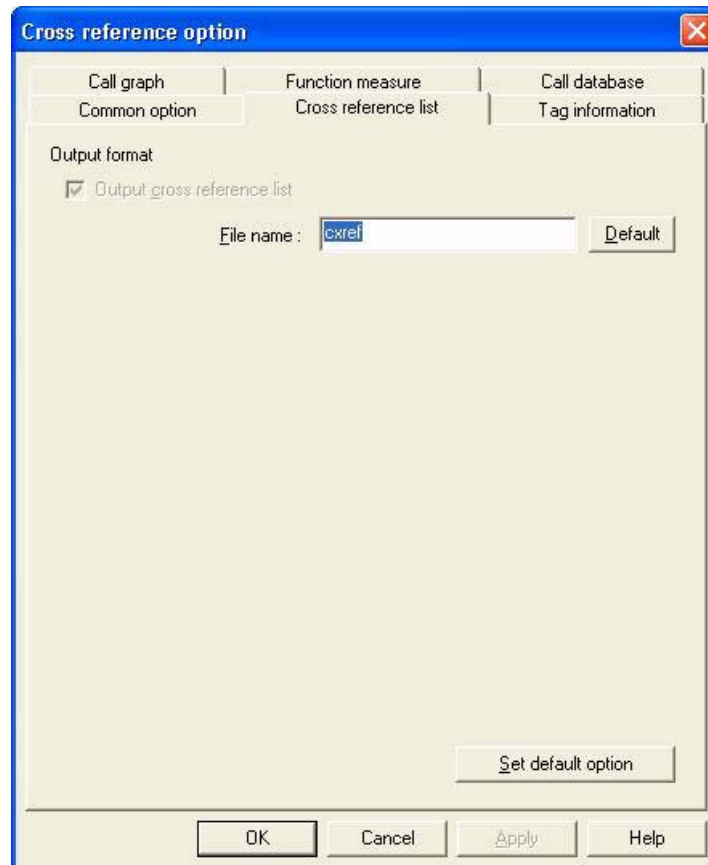

(1) Output format

If "Output cross reference list" is checked, the analysis result is output in the text format. This is not checked in the default condition.

Specify a file to which the analysis result is to be output in the text format, by using the "File name" edit box. The default file name is cxref. The default file name can also be specified by clicking the [Default] button

This setting box and the [Default] button can be selected only if "Output cross reference list" is selected.

If "Generate all analyzing files" is checked on the [Cross reference] tab, "Output cross reference list" remains on.

[Button]

(a) [Set default option] button

This button returns the current setting of the dialog box to the default status.

If "Generate all analyzing files" is checked on the [Cross reference] tab, "Output cross reference list" remains on.

[Tag information]

This tab is used to the tag information.

Figure 12 - 5 [Cross reference option] Dialog Box ([Tag information] Tab)

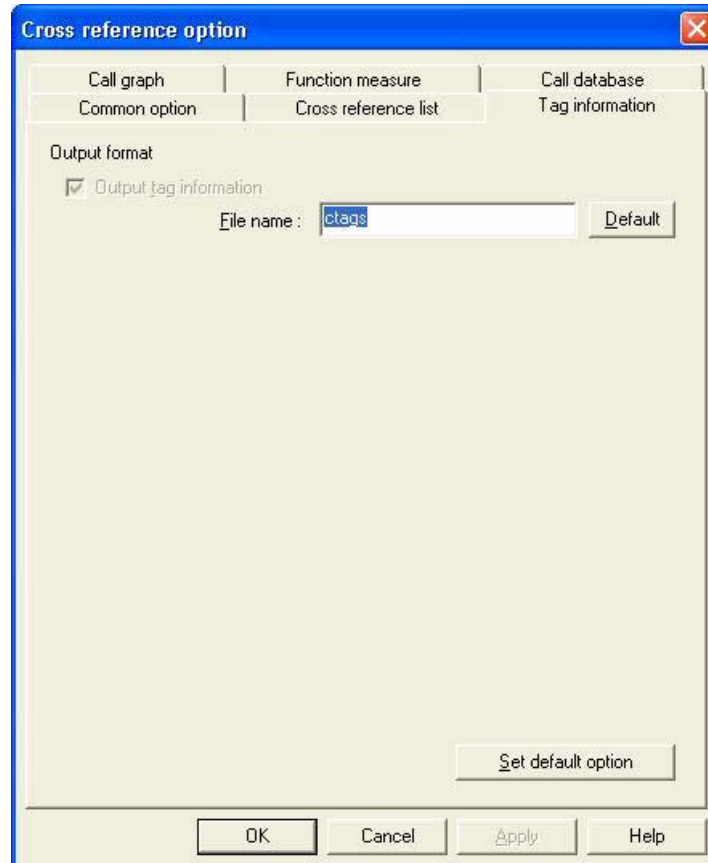

(1) Output format

If "Output tag information" is checked, the analysis result of the tag information is output in the text format. This is not checked in the default condition.

Specify a file to which the analysis result is to be output in the text format, by using the "File name" edit box. The default file name is ctags. The default file name can also be specified by clicking the Default button.

This setting box and the [Default] button can be selected only if "Output tag information" is selected.

If "Generate all analyzing files" is checked on the [Cross reference] tab, "Output cross reference list" remains on.

[Button]

(a) [Set default option] button

This button returns the current setting of the dialog box to the default status.

If "Generate all analyzing files" is checked on the [Cross reference] tab, "Output tag information" remains on.

[Call graph]

This tab is used to the call graph.

Figure 12 - 6 [Cross reference option] Dialog Box ([Call graph] Tab)

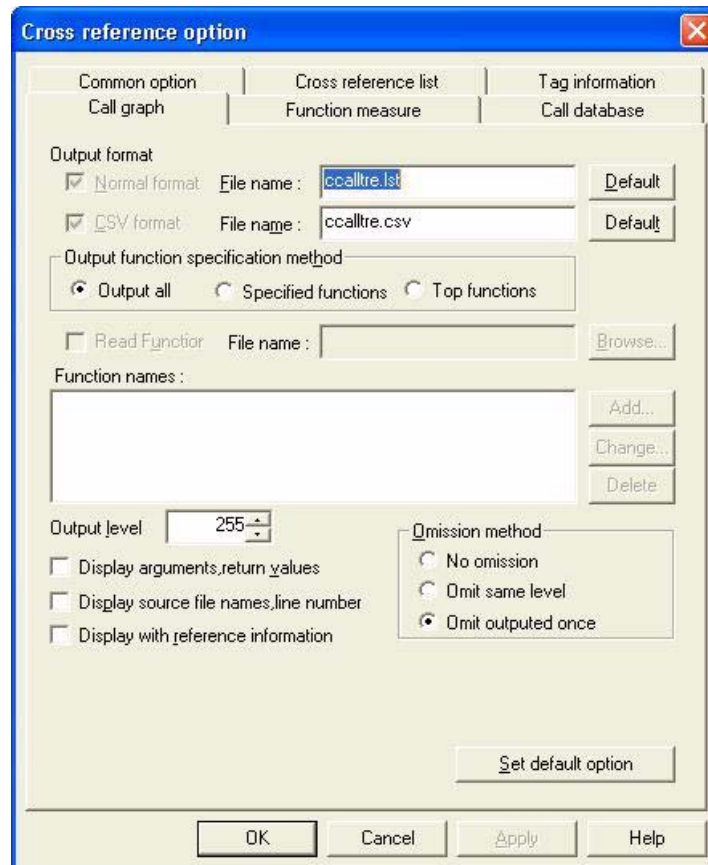

(1) Output format

If "Normal format" is checked, the analysis result of the leaf list is output in the text format. It is not checked in the default condition.

Specify a file to which the analysis result is to be output in the normal format, by using the "File name" edit box. The default file name is ccalltre.lst. The default file name can also be specified by clicking the [Default] button

This setting box and the [Default] button can be selected only when "Normal format" is selected.

If "CSV format" is checked, the analysis result of the leaf list is output in the CSV format. It is not checked in the default condition.

Specify a file to which the analysis result is to be output in the CSV format, by using the "File name" edit box. The default file name is ccalltre.csv. The default file name can also be specified by clicking the [Default] button

This setting box and the Default button can be selected only when "CSV format" is selected.

(2) Output function specification method

Select the method of specifying the functions to be output.

Output all:	All functions are output (default).
Specified functions:	Only the specified function is output. If this is selected, "Read Function", "Function names", and the [Add...] button of "Function names" can be selected.
Top functions:	Only the function at the top of the tree is output.

(3) Read Function

When this is checked, a function name is specified by using a file. This check box is not checked in the default condition.

"File name": Specifies a file in which functions are described on the edit box. This field is blank in the default condition.

When the [Browse...] button is clicked, the [Set analyze file] dialog box is opened and a file in which functions are described can be selected.

On the [Set analyze file] dialog box, the default positions are determined in the following order.

- (1) "Analyze folder" of the [\[Cross reference\]](#) tab
- (2) "Analyze file" of the [\[RAM map\]](#) tab
- (3) Install folder

Only when "Specified functions" is selected as "Output function specification method", this setting box, the "File name" edit box, and the [Browse...] button can be selected.

By clicking the [Apply] button after selecting a file, the functions specified in the specified file are displayed on the list of "Function names".

(4) Function names

An output function name is displayed on the list box. This box is blank in the default condition.

If a function name consists of more than 38 characters, the first 18 characters "..." + the last 18 characters of the function name are displayed.

If "Read function" is checked, this setting list box cannot be selected.

A function name is additionally displayed by clicking the [Add...] button. No function name can be directly input. When the [Add...] button is clicked, the [Set Function Name] dialog box is opened. Specify a function. The specified function is displayed on the list.

Select a function from the list and click the [Change...] button. The [Set Function Name] dialog box is opened, and the function is changed to the one selected on that dialog box.

When the [Delete] button is clicked, the function selected from the list is deleted.

The [Change] and [Delete] buttons can be selected only when a function is selected from the list.

(5) Output level

This specifies the output level of the analysis result on the edit box.

The output level can also be changed by using the spin button.

Only a numeric value can be specified in a range of 1 to 255. The default value is 255.

If the specified value is outside the range, a message box that indicates that the value is outside the range is opened by clicking the [OK] or [Apply] button

(6) Display arguments, return values

When this box is checked, the arguments and return value of the function are displayed. This box is not checked in the default condition.

(7) Display source file names, line number

When this box is checked, the source file name and description start line are displayed. This box is not checked in the default condition.

(8) Display with reference information

When this box is checked, the reference information of the function is displayed. This box is not checked in the default condition.

(9) Omission method

This field specifies the method of omission.

No omission	Does not omit the analysis result.
Omit same level	Does not output a function at the same level on the tree.
Omit output once	Does not output a function that has been output once (default).

[Button]**(a) [Set default option] button**

This button returns the current setting of the dialog box to the default status.

If "[Generate all analyzing files](#)" is checked on the [Cross reference] tab, however, "Normal format" and "CSV format" remain on.

[Function measure]

This tab is used to the function measure.

Figure 12 - 7 [Cross reference option] Dialog Box ([Function measure] Tab)

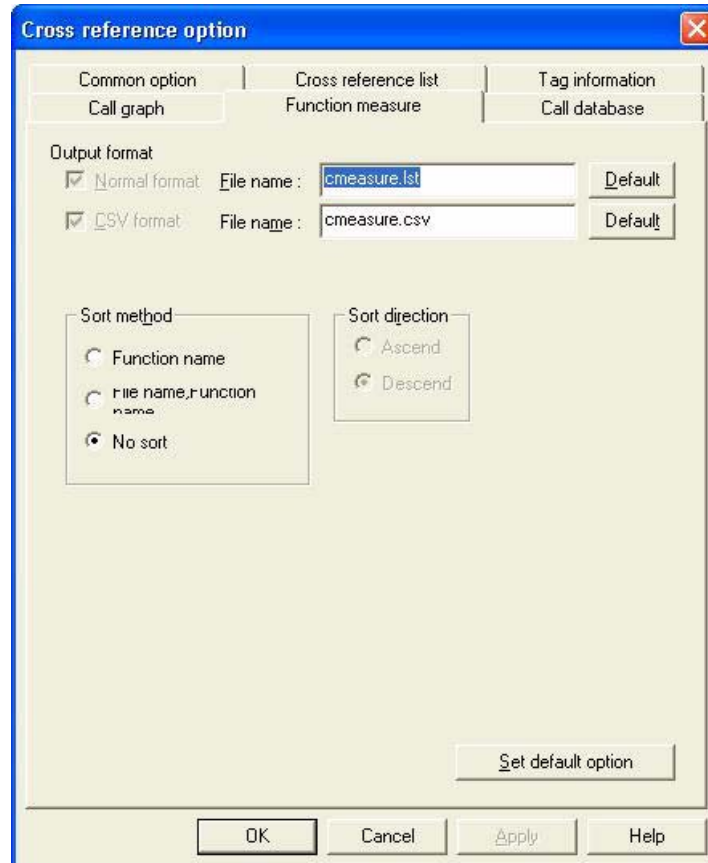

(1) Output format

If "Normal format" is checked, the analysis result of the leaf list is output in the text format. It is not checked in the default condition.

Specify a file to which the analysis result is to be output in the normal format, by using the "File name" edit box. The default file name is cmeasure.lst. The default file name can also be specified by clicking the [Default] button

This setting box and the Default button can be selected only when "Normal format" is selected. If "CSV format" is checked, the analysis result of the leaf list is output in the CSV format. It is not checked in the default condition.

Specify a file to which the analysis result is to be output in the CSV format, by using the "File name" edit box. The default file name is cmeasure.csv. The default file name can also be specified by clicking the [Default] button

This setting box and the Default button can be selected only when "CSV format" is selected. If "[Generate all analyzing files](#)" is checked on the [Cross reference] tab, however, "Normal format" and "CSV format" remain on.

(2) Sort method

Specify a method of sorting the analysis result. In the default condition, the result is not sorted (in appearance order).

If "No sort" is selected, the "Sort direction" setting box cannot be selected.

(3) Sort direction

Specify the direction in which the analysis result is to be sorted.

If "No sort" is selected, the "Sort direction" setting box cannot be selected.

Ascend	The analysis results are sorted in ascending order.
Descend	The analysis results are sorted in descending order (default).

[Button]**(a) [Set default option] button**

This button returns the current setting of the dialog box to the default status.

If "[Generate all analyzing files](#)" is checked on the [Cross reference] tab, however, "Normal format" and "CSV format" remain on.

[Call database]

This tab is used to the call database.

Figure 12 - 8 [Cross reference option] Dialog Box ([Call database] Tab)

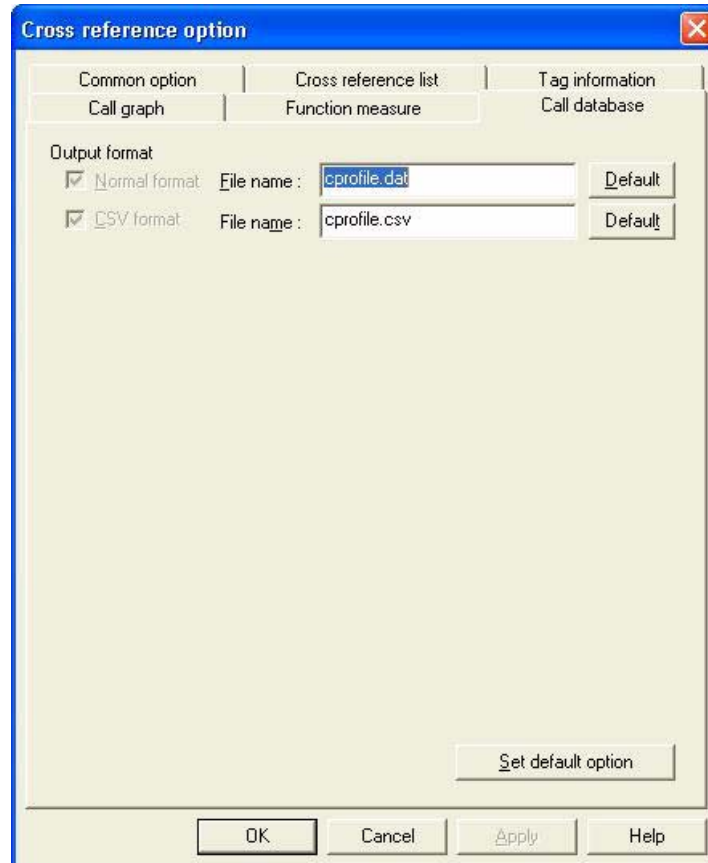

(1) Output format

If "Normal format" is checked, the analysis result of the call database is output in the text format. It is not checked in the default condition.

Specify a file to which the analysis result is to be output in the normal format, by using the "File name" edit box. The default file name is cprofile.dat. The default file name can also be specified by clicking the [Default] button

This setting box and the Default button can be selected only when "Normal format" is selected.

If "CSV format" is checked, the analysis result of the call database is output in the CSV format. It is not checked in the default condition.

Specify a file to which the analysis result is to be output in the CSV format, by using the "File name" edit box. The default file name is cprofile.csv. The default file name can also be specified by clicking the [Default] button

This setting box and the [Default] button can be selected only when "CSV format" is selected.

If "[Generate all analyzing files](#)" is checked on the [Cross reference] tab, however, "Normal format" and "CSV format" remain on.

[Button]

- (a) [Set default option] button

This button returns the current setting of the dialog box to the default status.

If "[Generate all analyzing files](#)" is checked on the [Cross reference] tab, however, "Normal format" and "CSV format" remain on.

12.6 Output Files

This section describes details about each output file.

12.6.1 Cross reference

Cxref outputs cross reference information of variables and functions that are used within the file, for each file.

The output destination is "standard output (default)" or a "text file." When information is output to a file, the default output file name is "cxref."

Figure 12 - 9 Cross Reference Output Example (cxref)

```
[Command input: cxref -x apli.c]

**** apli.c
G V NULL    20 30 43 90 91 199 204 205 235
G F combine #163 187 190
G F delete  #216 257
G V deleted #22 203 220 222
      ...
L V printtree:depth #232 236 242
G F removeitem #118 178 209
G F restore  #182 208 212
G V root    #20 42 113 115 115 221 223 224 224 224 261
      ...
```

The information is output in alphabetical order of the identifiers. Four types of information are output sequentially from left to right on each line.

(1) Linkage and storage class

The linkage and storage class are indicated by the following symbols.

G	Static external variable or function having external linkage
L	Static external variable, function, or static variable within a function, having internal linkage
?	Unknown

(2) Type

The type is indicated by the following symbols.

F	Function
V	Variable
?	Unknown

(3) Identifier name

The identifier name is the function name or variable name itself. However, since duplicate names may exist for variables that are defined within functions, identifier names are indicated in the format "function-name:variable-name".

(4) Line number

The definition line number and reference line numbers are listed with the following symbols appended.

!line-number ...	Declaration line
#line-number ...	Definition line
?line-number ...	Whether it is a declaration or definition or a reference is unknown
No symbol ...	Reference line

12.6.2 Tag information

Cxref outputs the definition file name and line number information (tag jump information) for variables and functions.

The output destination is "standard output (default)" or a "text file." When information is output to a file, the default output file name is "ctags."

Figure 12 - 10 Tag Information Output Example (cxref)

```
[Command input: cxref -t apli.c]

apli.c      163      G F combine
apli.c      216      G F delete
apli.c      22       G V deleted
apli.c      194      G F deletesub
apli.c      22       G V done
apli.c      108      G F insert
apli.c      54       G F insertitem
apli.c      86       G F insertsub
apli.c      21       G V key
...

```

The information is output in alphabetical order of the identifiers. Five types of information are output sequentially from left to right on each line.

(1) File name

Indicates the name of the file in which the variable or function is defined.

(2) Line number

Indicates the location of the variable or function definition.

(3) Linkage and storage class

The linkage and storage class are indicated by the following symbols.

G	Static external variable or function having external linkage
L	Static external variable, function, or static variable within a function, having internal linkage
?	Unknown

(4) Type

The type is indicated by the following symbols.

F	Function
V	Variable
?	Unknown

(5) Identifier name

The identifier name is the function name or variable name itself. However, since duplicate names may exist for variables that are defined within functions, identifier names are indicated in the format "function-name:variable-name."

(6) Line number

The definition line number and reference line numbers are listed with the following symbols appended.

!line-number	Declaration line
#line-number	Definition line
?line-number	Whether it is a declaration or definition or a reference is unknown
No symbol	Reference line

12.6.3 Call tree

When a call tree information output option such as `-c` is specified for `cxref`, the functions called by certain functions are output in tree format.

The output file format is text format or CSV format. To directly reference the main important information, output the data in text format. To reference detailed information in tabular form, output the data in CSV format.

(1) Text-format output example

If the `-c` option is specified, the call tree is output in text format.

The default output file name is "ccalltre.lst". The text-format output is as follows.

Figure 12 - 11 Call Tree Text-Format Output Example (cxref)

```
[Command input: cxref -c appli.c]

1  @newpage
2  |---malloc?
3  |---printf?
4  +---exit?
5  @search
6  @insertitem
7  @split
8  |---newpage...(1)
9  |---insertitem...(6)
10 +---insertitem...(6)
11 @insertsub
12 |---insertsub*
13 |---insertitem...(6)
14 +---split...(7)
    ...
```

- The group of functions to be processed are output in tree format.
- An ampersand "@" is appended to the front of a function name that is the tree root.
- Functions of provided libraries are also included in the tree.
- The meanings of symbols that are displayed after function names are as follows.

? ...	Indicates a function that is not defined in the file to be processed.
... (numerical value) ...	Indicates that subsequent outputs are omitted because it was output once. The numerical value indicates the line number for the first output.
* ...	Indicates that subsequent outputs were suspended because a recursive function was calling itself.

(2) CSV-format output example

If the `-cc` option is specified, the call tree is output in CSV format. A CSV-format file can be read by spreadsheet software such as Microsoft Excel.

The default output file name is "ccalltre.csv". The CSV-format output is as follows.

Figure 12 - 12 Call Tree CSV-Format Output Example (cxref)

```
[Command input: cxref -cc apli.c]

[SrcFileList]
No,SrcFileName,FilePath
1,apli.c,

[Funcs]
No,FuncName,SrcFileNo,LineNo,Ret1,Arg1,Ret2,Arg2
1,free,0,0,,,,
2,main,1,248,int,(),,
3,scanf,0,0,,,,
4,delete,1,217,void,(void),,
5,search,1,38,void,(void),,
...

[Calltree]
No,FuncNo,FuncAttr,TopFlg,ElimNo,ChildPtr,ChildCnt,RefFileNo,RefLine
1,8,0,1,0,1,3,0,0
2,7,0x21,0,0,0,0,1,30
3,12,0x21,0,0,0,0,1,31
4,9,0x21,0,0,0,0,1,32

[ChildFuncs]
No,CalltreeNo
1,2
2,3
3,4
4,8
5,9
6,10
7,12
8,13
9,14
10,16
...
```

[Explanation of Output Contents]**(1) [SrcFileList]**

The name of the source file in which the functions used by the program are defined is output.

FileName ...	Source file name.
FilePath ...	Source file path. This is output only when the path was specified for the file that was input.

(2) [Funcs]

All of the functions used by the program are output.

FuncName ...	Function name.
SrcFileNo ...	Source file number. Uses the "No" value in [SrcFileList] to indicate the source file in which that function is defined.
LineNo ...	Line number. Indicates the line at which that function's definition begins in the source file.
Ret1,Ret2 ...	Return values of the function. When the analysis cannot be performed, nothing is output.
Arg1,Arg2 ...	Arguments of the function. When the analysis cannot be performed, nothing is output.

(3) [Calltree]

The call tree is output.

FuncNo ...	Function number. Uses the "No" value in [Funcs] to indicate the function.
FuncAttr ...	Function attribute. Indicates the tree attributes by using a combination of the following numerical values. If there is no attribute, 0 is output. 0x0001 There is no program description. 0x0002 It is a recursive function. 0x0004 Omits subsequent tree output. 0x0008 Outputs source file name and description starting line. 0x0010 Outputs return values and arguments. 0x0020 Outputs reference information.
TopFlag ...	Top flag. When the function is the tree root, 1 is output. When it is not the tree root, 0 is output.
ElimNo ...	Tree number for previous output. When the function corresponds to "0x0004" for "FuncAttr," this uses "No" in [Calltree] to indicate the tree in which that function was previously output. If it does not correspond to "0x0004," 0 is output.
ChildPtr ...	Starting position of child function display. Uses "No" in [ChildFuncs] to indicate the position at which the first child function of the function is output.
ChildCnt ...	Number of child functions. Indicates the number of child functions registered in [ChildFuncs]. If there is no child function, 0 is output.

(4) [ChildFuncs]

The tree in which that child function exists is output as child function information.

CallTreeNo ...	Tree number. Uses "No" in [Calltree] to indicate the tree in which that child function exists.
----------------	--

12.6.4 Function metrics

When a function metrics information output option such as `-m` is specified for `cxref`, the information is output in terms of individual functions.

The output file format is text format or CSV format. To directly reference the main important information, output the data in text format. To reference detailed information in tabular form, output the data in CSV format.

(1) Text-format output example

If the `-m` option is specified, the function metrics are output in text format.

The default output file name is "cmeasure.lst". The text-format output is as follows.

Figure 12 - 13 Function Metrics Text-Format Output Example (cxref)

```
[Command input: cxref -m apli.c]
      Flie   Line   Called
newpage  apli.c   27      2
search   apli.c   38      1
insertitem apli.c   55      3
split    apli.c   68      1
insertsub apli.c   87      2
insert   apli.c  109     1
removeitem apli.c  119     2
moveright apli.c  128     1
moveleft  apli.c  146     1
combin    apli.c  164     2
restore   apli.c  183     2
deletesub apli.c  195     3
delete    apli.c  217     1
printtree apli.c  231     3
main      apli.c  248     0
      ...
```

[Explanation of Output Contents]

(1) Flie

File name. Indicates the name of the source file in which that function is defined.

(2) Line

Starting line. Indicates the line number in the source file at which that function is defined.

(3) Called

Call histogram. Indicates the frequency with which that function was called. The frequencies that are output are based on the assumption that the function is called once for each function call description.

(2) CSV-format output example

If the `-mc` option is specified, the function metrics are output in CSV format. A CSV-format file can be read by spreadsheet software such as Microsoft Excel.

The default output file name is "cmeasure.csv". The CSV-format output is as follows.

Figure 12 - 14 Function Metrics CSV-Format Output Example (cxref)

```
[Command input: cxref -mc apli.c]

[SrcFileList]
No,SrcFileName,FilePath
1,apli.c,

[Funcs]
No,FuncName,SrcFileNo,LineNo,Ret1,Arg1,Ret2,Arg2
1,free,0,0,,,,
2,main,1,248,int,(),,
3,scanf,0,0,,,,
4,delete,1,217,void,(void),,
5,search,1,38,void,(void),,
...

[Measure]
No,FuncNo,FuncSz,Clk,TClk,Stk,TStk,CalledCnt,StkUp,StkUpPtr,StkUpCnt,ClkUp,
ClkUpPtr,ClkUpCnt,StkDw,StkDwPtr,StkDwCnt,ClkDw,ClkDwPtr,ClkDwCnt
1,8,64,37,37,12,68,2,68,1,4,496,5,4,12,0,0,37,0,0
2,5,208,118,118,12,24,1,24,9,1,237,10,1,12,0,0,118,0,0
3,19,148,71,71,16,72,3,72,11,4,530,15,4,16,0,0,71,0,0
...
```

[Explanation of Output Contents]**(1) [SrcFileList]**

The name of the source file in which the functions used by the program are defined is output.

FileName ...	Source file name.
FilePath ...	Source file path. This is output only when the path was specified for the file that was input.

(2) [Funcs]

All of the functions used by the program are output.

FuncName ...	Function name.
SrcFileNo ...	Source file number. Uses the "No" value in [SrcFileList] to indicate the source file in which that function is defined.
LineNo ...	Line number. Indicates the line at which that function's definition begins in the source file.
Ret1,Ret2 ...	Return values of the function. When the analysis cannot be performed, nothing is output.
Arg1,Arg2 ...	Arguments of the function. When the analysis cannot be performed, nothing is output.

(3) [Measure]

Function metrics information is output.

FuncNo ...	Function number. The "No" value in [Funcs] is used to indicate the function.
CalledCnt ...	Call histogram. Indicates the frequency with which that function was called. The frequencies that are output are based on the assumption that the function is called once for each function call description.

12.6.5 Call database

When a call database information output option such as `-b` is specified for `cxref`, the functions called by a given function and the number of times each function is called by that function are output.

The output file format is text format or CSV format. To directly reference the main important information, output the data in text format. To reference detailed information in tabular form, output the data in CSV format.

(1) Text-format output example

If the `-b` option is specified, the call database is output in text format.

The default output file name is "cprofile.dat". The text-format output is as follows.

Figure 12 - 15 Call Database Text-Format Output Example (cxref)

```
[Command input: cxref -b apli.c]

newpage,apli.c,malloc,0,1
newpage,apli.c,printf,0,1
newpage,apli.c,exit,0,1
split,apli.c,newpage,apli.c,1
split,apli.c,insertitem,apli.c,2
insertsub,apli.c,insertsub,apli.c,1
insertsub,apli.c,insertitem,apli.c,1
insertsub,apli.c,split,apli.c,1
insert,apli.c,insertsub,apli.c,1
insert,apli.c,newpage,apli.c,1
combine,apli.c,removeitem,apli.c,1
combine,apli.c,free,0,1
...
```

Five types of information are output sequentially from left to right on each line.

- (1) Calling function name.
- (2) Name of source file in which calling function is defined. If no analysis can be performed, "???" is output.
- (3) Called function name.
- (4) Name of source file in which called function is defined. Since the source file name is unknown for a function in a library, 0 is output.
- (5) Number of times called function is called within calling function.

(2) CSV-format output example

If the `-bc` option is specified, the call database is output in CSV format. A CSV-format file can be read by spreadsheet software such as Microsoft Excel.

The default output file name is "cprofile.csv". The CSV-format output is as follows.

Figure 12 - 16 Call Database CSV-Format Output Example (cxref)

```
[Command input: cxref -bc apli.c]

[SrcFileList]
No,SrcFileName,FilePath
1,apli.c,

[Funcs]
No,FuncName,SrcFileNo,LineNo,Ret1,Arg1,Ret2,Arg2
1,free,0,0,,,
2,main,1,248,int,(),,
3,scanf,0,0,,,
4,delete,1,217,void,(void),,
5,search,1,38,void,(void),,
...
[CallDataBase]
No,FuncNo,ChildFuncNo,CallCnt
1,8,7,1
2,8,12,1
3,8,9,1
4,11,8,1
5,11,19,2
...
```

[Explanation of Output Contents]**(1) [SrcFileList]**

The name of the source file in which the functions used by the program are defined is output.

FileName ...	Source file name.
FilePath ...	Source file path. This is output only when the <code>-p</code> option is specified.

(2) [Funcs]

All of the functions used by the program are output.

FuncName ...	Function name.
SrcFileNo ...	Source file number. Uses the "No" value in [SrcFileList] to indicate the source file in which that function is defined.
LineNo ...	Line number. Indicates the line at which that function's definition begins in the source file.
Ret1,Ret2 ...	Return values of the function. When the analysis cannot be performed, nothing is output.
Arg1,Arg2 ...	Arguments of the function. When the analysis cannot be performed, nothing is output.

CHAPTER 13 MEMORY LAYOUT VISUALIZATION TOOL

This chapter presents an overview of the memory layout visualization tool (rammap) and describes its operation, and output file format.

13.1 Memory Layout Visualization Tool

The memory layout visualization tool displays the memory map information of a specified executable object file. The memory layout visualization tool of the C compiler package is "rammap".

This tool outputs the memory map information of values to a text-format file and CSV-format file.

Figure 13 - 1 Flow of Operation in rammap

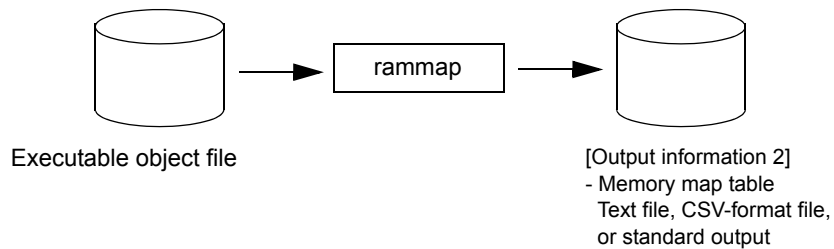

13.2 Input/Output

13.2.1 Input file

The input file of rammap is an executable object file^{Note} (.out file) output by the ld850.

Note Does not include a re-linkable object file or a file (.out file) output by the romp850.

13.2.2 Output information

The information that is output by rammap is a memory map that shows the variable names, sizes, and memory layout.

(1) [Memory map table](#)

A memory map that shows the variable names, sizes, and memory layout is output.

For details about this information, refer to "[13.6 Output Files](#)" and following.

13.3 Operation Method

This section explains operations for rammap.

13.3.1 Command input method

Enter the following from the command prompt (Windows).

```
rammap [option] [file]
[ ] : Can be omitted.
```

13.3.2 Method using PM+

The RAM map can be used in PM+ with the following two methods.

(1) Using in the [\[Static performance analyzer\] dialog box](#)

The RAM map setting dialog box is displayed through the following operation after configuring the project in PM+.

- Select [Tool] - [Static performance analyzer], then click the [\[RAM map\]](#) tab

(2) Using in the [\[Object Analysis Tool\] dialog box](#)

The RAM map activation dialog box is displayed through the following operation after configuring the project in PM+.

- Select [Tool] - [Startup Object Analysis Tool...], then click the [\[RAM map\]](#) tab

Since the memory layout visualization tool is activated once per project, there are no file-specific settings.

13.4 Types and Features of Options

The rammap options are shown below.

-v

This option outputs the version number of rammap and then terminates processing.

-all

This option outputs all information to a text-format file and CSV-format file.

This option has the same result as when "-mall" is specified.

-h

-help

This option outputs an explanation of the options and then terminates processing.

-m [=file]

This option outputs a memory map table to the specified file in text format.

If [=file] is omitted, rammap.txt is assumed for the file name.

-mall [=file]

This option outputs a memory map table to the specified file in text format and CSV format.

The file names are file.lst and file.csv. If an extension is appended to the specification for file, that extension is ignored.

If [=file] is omitted, rammap.txt and rammap.csv are assumed for the file names.

-mc [=file]

This option outputs a memory map table to the specified file in CSV format. If [=file] is omitted, rammap.csv is assumed for the file name.

-mrange

This option specifies the range for outputting the memory map table.

[Specification method]

The output range for the memory map table can be specified by using the following three methods.

- (1) Specify the starting address and ending address.

```
rammap a.out -mr0x10000-0x20000
```

- (2) Specify only the starting address. In this case, the ending address will be 0xffffffff.

```
rammap a.out -mr0x10000-
```

- (3) Specify only the ending address. In this case, the starting address will be 0x0.

```
rammap a.out -mr-0x20000
```

- Do not insert a space between "-mr" and the range.
- Octal, decimal, or hexadecimal numbers can be specified for the addresses.

Octal specification format	-mr0200000-0400000
Decimal specification format	-mr65536-131072
Hexadecimal specification format	-mr0x10000-0x20000

[Multiple range specification]

Multiple ranges can be specified. To specify multiple ranges, either specify multiple -mr options or separate each of the ranges with commas.

(1) Method of specifying multiple -mr options

```
rammap a.out -mr0x10000-0x20000 -mr0x30000-0x40000
```

(2) Method of separating ranges with commas

```
rammap a.out -mr0x10000-0x20000,0x30000-0x40000
```

- When specified ranges overlap, they are handled as follows.

Example1

```
a ----- b   c ----- d
```

This case is handled as one in which the two ranges a to b and c to d are specified.

Example2

```
a ----- b
           c ----- d
```

This case is handled as one in which the one range a to d is specified.

Example3

```
a ----- b
           c ----- d
```

This case is handled as one in which the one range a to d is specified.

Example4

```
a ----- b
           c ----- d
```

This case is handled as one in which the one range a to b is specified.

Cautions1 The actual address range is aligned at 16 bytes. For the starting address, the specified value is rounded to 16 bytes (logical AND with 0xfffff0). For the ending address, the specified value is rounded to 16 bytes and added to 0xF.

-mr0x10000-0x20000	0x10000-0x2000f
-mr0x10004-	0x10000-0xffffffff
-mr-0x20005	0x0-0x2000f

Cautions2 If the range specification is illegal, an error message is output, and processing is interrupted.

-mstd

This option outputs a text-format memory map table to standard output.

-o path

This option specifies the path of the output file. If this option is omitted, the information is output to the current path.

@cfile

This option handles *cfile* as a command file. A command file specifies an option and a file name for a command not as arguments on the command line but by describing them in a file. On Windows, the length of a character string specified as an option of a command is limited. If many options are set and some of the options cannot be recognized, create a command file and specify this option.

For details of the command file, refer to "[3.7.2 Command file](#)".

13.5 Settings Made via PM+

This section explains the respective dialog boxes that are used to set command options of the rammap for a file of the targeted project.

13.5.1 [Static performance analyzer] dialog box

At the upper part of this dialog box, the following two tabs are displayed.

The contents of this dialog box depend on selecting the following tab.

Table 13 - 1 [Static performance analyzer] Dialog Box (rammap)

Tab	Description
[Cross reference]	Setting of cross reference options
[RAM map]	Setting of RAM map options

[RAM map]

This tab is used to set the "RAM map".

Figure 13 - 2 [Static performance analyzer] Dialog Box ([RAM map] Tab)

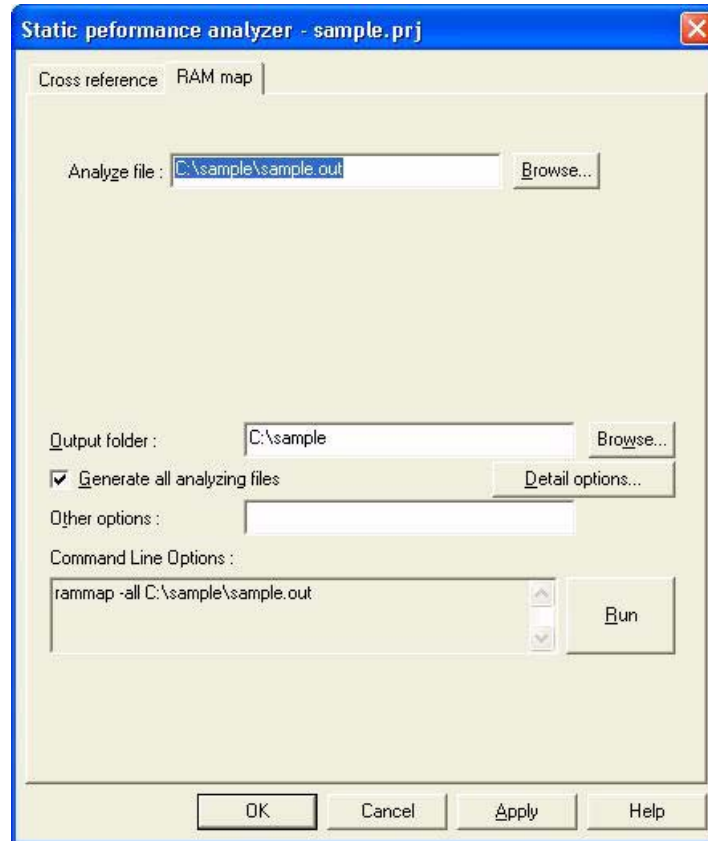

(1) Analyze file

Specify the file subject to analysis by using the edit box.

Specify the object file (*.out) output by the linker. The default assumption is as follows.

- If an option is saved, the file to which the option is saved is assumed as the file subject to analysis.
- If an option is not saved, the target information registered to the project file is displayed.

Clicking the [Browse...] button displays the [Browse for Folder] dialog box in which the file subject to analysis can be selected. The selected file is displayed in "Analyze file".

In the [Browse for Folder] dialog box, the default position is determined in the following sequence:

- (1) Folder of "Analyze file" on this tab
- (2) Path of "Output folder" on this tab
- (3) "Analyze folder" on the [\[Cross reference\]](#) tab
- (4) Install folder

(2) Output folder

Specify the analysis result output destination (folder) in the edit box.

The default assumption is as follows.

- If an option is saved, the output destination of the saved analysis result is assumed.
- If an option is not saved, the folder in which the project file is placed is assumed.

If the specified folder does not exist, clicking the [OK] or [Apply] button opens the folder creation dialog box.

When the [OK] button is selected on this dialog box, a folder is created.

Clicking the [Browse...] button opens the [Browse for Folder] dialog box where the folder to which the analysis result is to be output can be selected. The selected folder is displayed in "Output folder".

In the [Browse for Folder] dialog box, the default position is determined in the following sequence:

- (1) Folder of "Analyze file" on this tab
- (2) Path of "Output folder" on this tab
- (3) "Analyze folder" on the [\[Cross reference\]](#) tab
- (4) Install folder

(3) Generate all analyzing files

If this is checked, the option contents are set as default contents. This check box is checked in the default condition.

(4) Detail options

Clicking this button opens the [\[RAM map option\] dialog box](#) for setting the RAM map options where the option of each function can be set.

(5) Other options

Options can be directly specified in the edit box. This box is blank in the default condition.

(6) Command Line Options

A list of options is displayed. "rammap-all" is displayed in the default condition.

Clicking the [Run] button analyzes the specified file with the set options. The analysis command in install folder is executed.

If no file is specified for analysis, a message box is opened, displaying a message indicating that no file is specified.

Depending on the result of the analysis, a message box reporting normal or abnormal termination is opened.

The output message of the analysis command is output to file rammap.log in the folder at the analysis result output destination or that in the folder of the analysis folder.

13.5.2 [RAM map option] dialog box

This dialog box is displayed by clicking the "Detail options" button on the [RAM map] tab in the [Static performance analyzer] dialog box

At the upper part of this dialog box, the following one tab is displayed.

Table 13 - 2 [RAM map option] Dialog Box

Tab	Description
[Common option]	Setting of common options.

[Common option]

This tab is used to set common options.

Figure 13 - 3 [RAM map option] Dialog Box ([Common option] Tab)

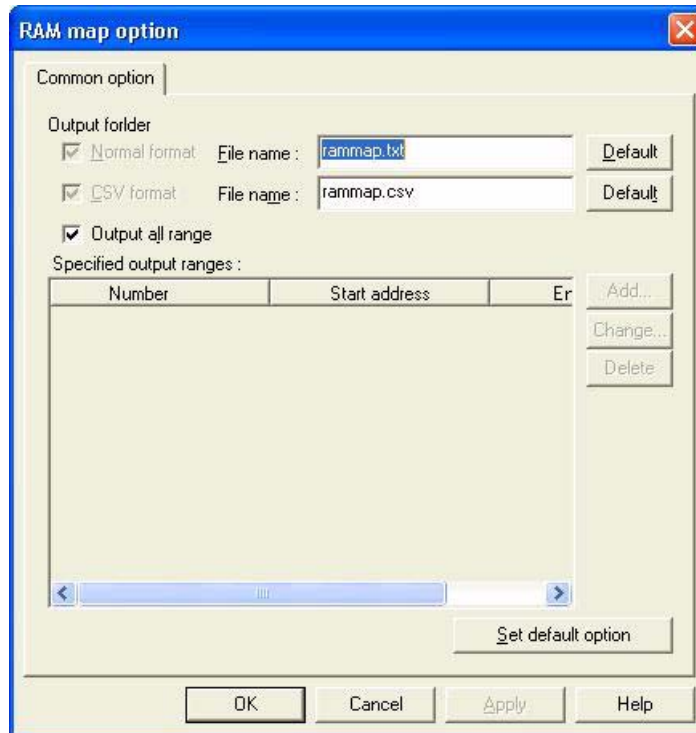

(1) Output folder

Checking "Normal format" outputs the analysis result of the RAM map in the text format. This is not checked in the default condition.

Specify the name of a file to which the analysis result in the normal format is to be output by using the "File name" edit box. The default file name is rammap.txt. The default file name can also be selected by clicking the [Default] button

This setting box and the [Default] button can be selected only when "Normal format" is selected.

If "CSV format" is checked, the result of analysis of the RAM map is output in the CSV format. This is not checked in the default condition.

Specify the name of a file to which the analysis result in the CSV format is to be output, by using the "File name" edit box. The default file name is rammap.csv. The default file name can also be selected by clicking the [Default] button

This setting box and the Default button can be selected only when "CSV format" is selected.

If "Generate all analyzing files" is checked on the [RAM map], however, "Normal format" and "CSV format" remain on.

(2) Output all range

If this is checked, a function name can be specified by using a file. It is not checked in the default condition.

If it is checked, "Specified output ranges" and the [Add...] button cannot be selected.

(3) Specified output ranges

An output range is displayed in the list box that is blank in the default condition.

Clicking the [Add...] button displays the start address and end address. Addresses cannot be directly input.

Clicking the [Add...] button opens the [Set output range] dialog box in which the start address and the end address can be specified. The specified start and end addresses are displayed in the list.

In the [Set output range] dialog box, data can be input in hexadecimal number, and can be set in the range of 0 to 0xffffffff. No range is displayed in the default condition. If a value outside the range is specified, a message box indicating that the specified value is outside the range is opened.

If the start and end addresses are selected from the list and then the [Change...] button is clicked, the [Set output range] dialog box is opened, and the addresses are changed into the start and end addresses selected in this dialog box. The default addresses are the start and end addresses selected from "Specified output ranges".

In the [Set output range] dialog box, data can be input in hexadecimal number, and can be set in the range of 0 to 0xffffffff. No range is displayed in the default condition. If a value outside the range is specified, a message box indicating that the specified value is outside the range is opened, and the value is ignored.

Clicking the Delete button deletes the function selected from the list.

The [Change...] and [Delete] buttons can be selected only if the start and end addresses are selected from the list.

If "Output all range" is selected, this setting box and the [Add], [Change...], and [Delete] buttons cannot be selected.

[Button]**(a) [Set default option] button**

This button returns the current setting of the dialog box to the default status.

If "Generate all analyzing files" is checked on the [RAM map], however, "Normal format" and "CSV format" remain on.

13.5.3 [Object Analysis Tool] dialog box

At the upper part of this dialog box, the following three tabs are displayed.

The contents of this dialog box depend on selecting the following tab.

Table 13 - 3 [Object Analysis Tool] Dialog Box (rammap)

Tab	Description
[Dump]	Setting of options related to dump command
[Disassembler]	Setting of options related to disassembler
[RAM map]	Setting of options related to RAM map

[RAM map]

For the RAM map activation dialog box, set the project settings in the PM+, then select the [RAM map] tab in the dialog opened by selecting [Tool] - [Startup Object Analysis Tool...].

Figure 13 - 4 [Object Analysis Tool] Dialog Box ([RAM map] Tab)

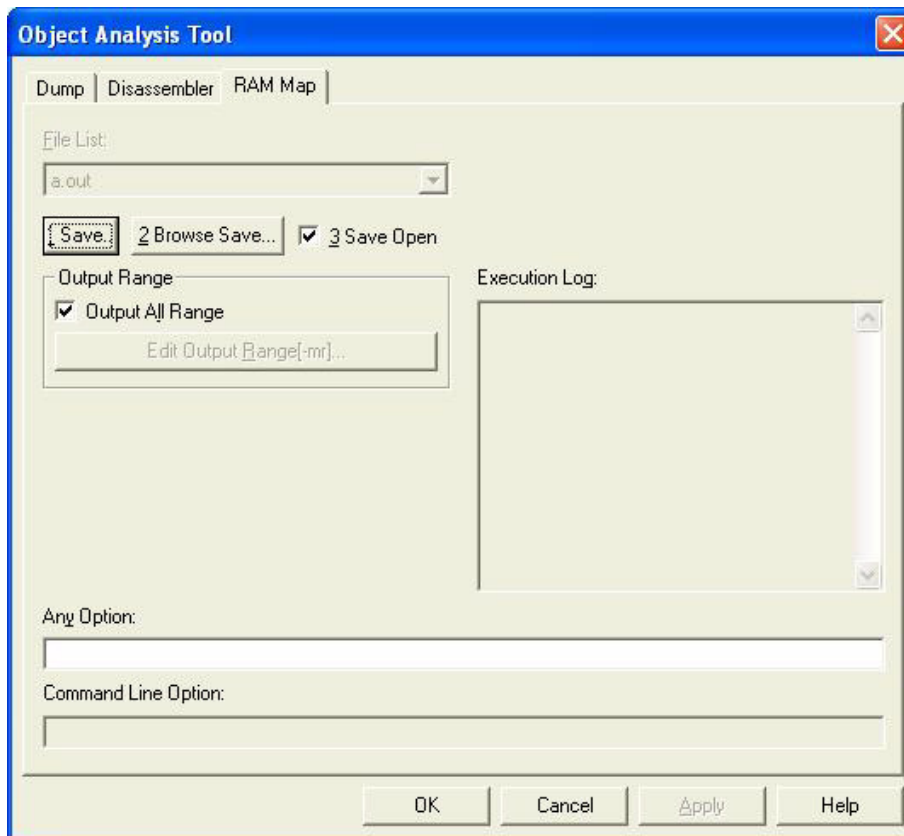

(1) File List

Object files for building in the project are displayed in the drop-down list. (Paths are not displayed in the list.)

The following files are displayed in the list (This drop-down list is usually unavailable).

- Linker output files (only for projects in which executable object files are built)

Open the [Save As] dialog box with the [1 Save...] button and save the RAM map of the object file specified in "File List". By default, it is saved as "object-file-name.txt" in the same folder as the object file specified in "File List".

Also, if "*.csv" is specified in the [Save As] dialog box, it will be saved in CSV format (otherwise it will be saved in text format.)

This button is unavailable for projects in which libraries are built.

With the [2 Brows Save...] button, the RAM map can be saved by specifying the object file. In this case, the [Open] dialog box is opened, so specify the object file. By default, folders specified in previous [Open] dialog boxes or project folders are displayed.

When an object file is specified in the [Open] dialog box, the RAM map for the specified object file is saved in text format.

(2) 3 Save Open

After saving the RAM map with the [1 Save...] or [2 Browse Save...] button, this specifies whether or not to open the file which was saved with the editor or affiliated application (for CSV format) set in PM+.

It is selected by default.

(3) Output Range**(a) Output All Range**

Checking this box invalidates the -mr option.

It is selected by default.

(b) [Edit Output Range[-mr]...] button

This opens the [\[Edit Option\] dialog box](#) for editing the output range specified with the -mr option.

(4) Execution Log

This displays the RAM map execution log.

Since this area is for reference purposes, it cannot be written to.

(5) Any Option

This specifies options that cannot be set in the "rammap command options" described before. This edit box displays in the same format as the command line.

In addition, since all rammap command-related options can be specified in this dialog box, it is not necessary to use any other options.

(6) Command Line Option

Options specified in the dialog box are displayed in the command line options.

Since this area is for reference purposes, it cannot be written to.

13.6 Output Files

This section describes details about output files.

13.6.1 Memory map table

rammap outputs a memory map table that shows variable names, sizes, and the memory layout.

The output destination is "standard output" or a "file." When information is output to a file, the output file format is text format or CSV format. To directly reference the main important information, output the data in text format. To reference detailed information in tabular form, output the data in CSV format.

- The memory map table has 16 bytes per line.
- For a variable name, the name in the C language source file is displayed in the following format (when the variable name is assumed to be "name").

External variable	<code>_name</code>
Local variable within file	<code>file@_name</code>
Static variable or string constant within function	<code>file@LL-number</code>

- The size is displayed in the format "(number of bytes in decimal notation)" following the variable name.

(1) Text-format output example

If the `-m` option is specified, the memory map table is output in text format.

The default output file name is "rammap.txt". The text-format output is as follows.

Figure 13 - 5 Memory Map Table Text-Format Output Example (rammap)

```
[Command input: rammap -m a.out]

Address  +0  +1  +2  +3  +4  +5  +6  +7  +8  +9  +A  +B  +C  +D  +E  +F
-----+--+-----+--+-----+--+-----+--+-----+--+-----+--+-----+
0x00000000 |
:
0x00FFE000 | crtN.s@__argc (> | crtN.s@__argv (> | test.c@LL29 (5) -
0x00FFE010 | --> | test.c@svar (4> | _var (4) -----> | _gAppName (8) ---
0x00FFE020 | -----> | _c> | _tmp (4) -----> | _buf (100) -----
:
0x00FFE080 | -----> |
0x00FFE090 | _var2 (4) -----> | _c> | crtN.s@__stack (512) -----
:
0x00FFE290 | -----> |
:
0xFFFFFFFF0 |
-----+--+-----+--+-----+--+-----+--+-----+--+-----+
...
```

- The variable name and size are displayed left-justified at the start of the relevant address.
- A variable name that cannot fit in the memory layout frame is displayed as far as it fits.
- A colon (:) is output for a line that has no variable name, and the line is omitted. Unused area, the text attribute section, and the interior of large variables correspond to these kinds of lines.

(2) CSV-format output example

If the `-mc` option is specified, the memory map table is output in CSV format. A CSV-format file can be read by spreadsheet software such as Microsoft Excel.

The default output file name is "rammap.csv". The CSV-format output is as follows.

Figure 13 - 6 Memory Map Table CSV-Format Output Example (rammap)

```
[Command input: rammap -mc a.out]

Address,0,1,2,3,4,5,6,7,8,9,A,B,C,D,E,F
0x00000000,,,,,,,,,,,,,
:
0x00FFE000,crtN.s@__argc(4),,,,crtN.s@__argv(4),,,,,,test.c@LL29(5),,,
0x00FFE010,,,,,test.c@_svar(4),,,,_var(4),,,,_gAppName(8),,,
0x00FFE020,,,,,_cInput(1),,,,_tmp(4),,,,_buf(100),,,
:
0x00FFE090,_var2(4),,,,_c(1),,,,crtN.s@__stack(512),,,,,,
:
0xFFFFFFFF,,,,,,,,,,,,,
...
```

- A colon (:) is output for a line that has no variable name, and the line is omitted. Unused area, the text attribute section, and the interior of large variables correspond to these kinds of lines.

CHAPTER 14 STACK USAGE TRACER

This chapter explains the outline, operation method, and output format of the stack usage tracer (stk850).

14.1 Flow of Operation

The stack usage tracer "stk850" is a tool that calculates statically the amount of the stack each function may use during execution and displays the result in tree form, based on the intermediate assembly language file (.s) output by the ca850.

The stk850 has the following features:

- It works with PM+.
- The result of calculating the stack size is displayed in GUI.
- It provides an easy user interface to specify additional stack size information.

Figure 14 - 1 Estimation Flow in stk850

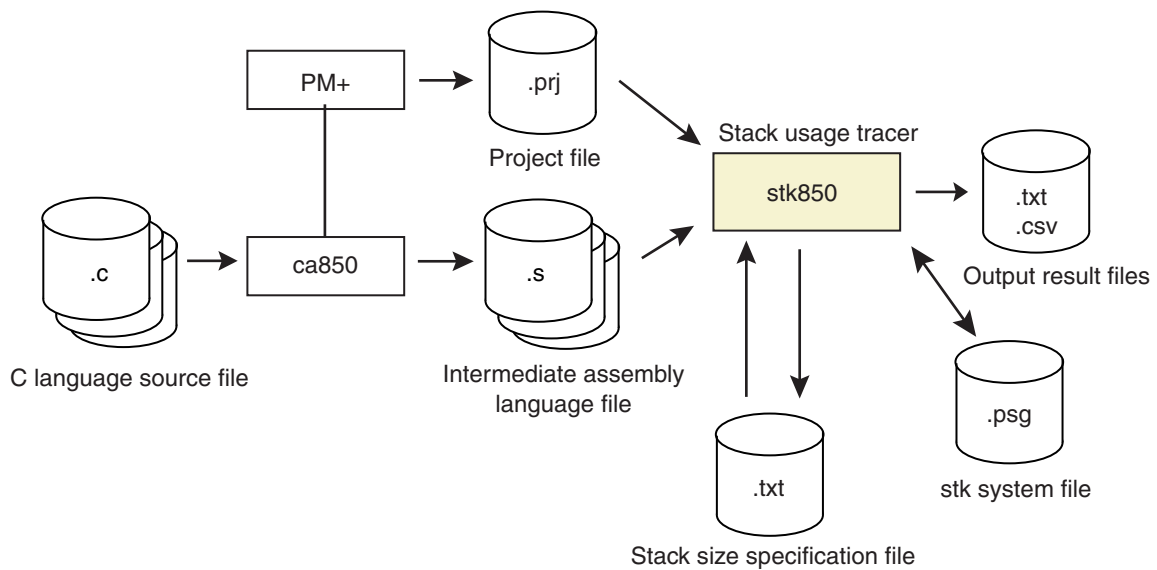

14.2 Input/Output Files

14.2.1 Input files

The following files are input to the stk850.

(1) Project file

The stk850 automatically reads the information of the active project in PM+.

(2) Intermediate assembly language file

An intermediate assembly language file is an intermediate assembly language source that the ca850 outputs from the C language source file registered in the project file. Based on the intermediate assembly language files, the stk850 analyzes the amount of the stack used. Users cannot specify an individual intermediate assembly language file.

(3) [Stack size specification file](#)

The stk850 accepts a user-written file which contains additional stack size information.

Besides, the stk850 uses (installation folder of the stk850)\dat850*.txt as the stack size specification file for the standard library functions.

Refer to "[14.6.2 Stack size specification file](#)".

(4) [stk system file](#)

Refer to "[14.6.3 stk system file](#)".

14.2.2 Output file

The following files are output from the stk850.

(1) [Output result files](#)

Refer to "[14.6.1 Output result files](#)".

(2) [Stack size specification file](#)

Refer to "[14.6.2 Stack size specification file](#)".

(3) [stk system file](#)

Refer to "[14.6.3 stk system file](#)".

14.3 Operation Method

This section describes the operation methods for the stk850.

Follow the steps below to start the stk850 from PM+.

- (1) Specify the "[Assembler Source\[-Fs\]](#)" in the [\[General\]](#) tab of the [\[Compiler Options\]](#) dialog box, and then rebuild.
- (2) Select [\[Tool\]](#) - [\[Startup STK850\]](#).

The [Main window](#) of the stk850 then appears, showing the result of stack size calculation for the current project.

Caution To calculate the stack sizes, the intermediate assembly language files are required.

14.4 Window Reference

The stk850 has following windows and dialog boxes.

Table 14 - 1 Windows and Dialog Boxes of stk850

Window/Dialog Box Name	Description
Main window	Window that appears first after the stk850 starts up. Displays the stack size for each function.
[Adjust Stack Size] dialog box	Dialog box to specify additional stack size information of functions.
[Stack Size Unknown / Adjusted Function Lists] dialog box	Dialog box that shows stack size unknown functions and adjusted functions.
[About stk850] dialog box	Dialog box that shows the version of the stk850.

Main window

The Main window appears first after the stk850 starts up. It displays the call tree and the stack size for each function.

Figure 14 - 2 Main Window of st850

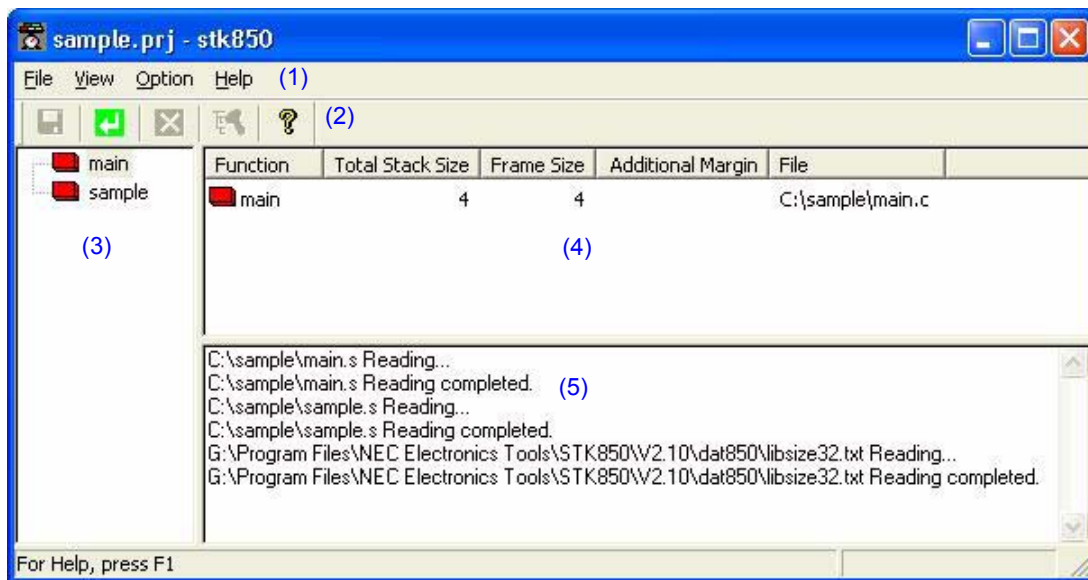

(1) Menu bar

(a) [File]

Open Project...	Opens a project file and recalculates the stack size.
Save Call Chain with Maximum Stack from Selected Function...	Saves the stack size of the largest path of the selected function's stack size to the file.
Save All Call Chains from Selected Function...	Saves the stack sizes of all the paths under the selected function to the file.
Save Call Chain with Maximum Stack from Every Root...	Saves the stack size of the largest path of all the root function stack sizes to the file.
Save All Call Chains from Every Root...	Saves the stack sizes of all paths to the file.
Load Stack Size Specification File...	Reads the information of in a stack size specification file.
Save Stack Size Specification File...	Saves the stack size specification information into a file.
Exit stk850	Terminates the stk850.

(b) [View]

Recalculate Stack Size	Recalculates the stack size.
Stop	Aborts the currently running jobs.
Sort List by	Sorts the list display area according to the selected menu.
Function Name	Sorts the list display area in the order of function names.
Icon Type	Sorts the list display area by icon types.
Stack Size	Sorts the list display area in the order of total stack sizes.
Frame Size	Sorts the list display area in the order of frame sizes.
Additional Margin	Sorts the list display area in the order of additional margins.
File Name	Sorts the list display area in the order of file names.





(c) [Option]

[Stack Size Unknown / Adjusted Function Lists] dialog box	Opens the [Stack Size Unknown / Adjusted Function Lists] dialog box .
[Adjust Stack Size] dialog box	Opens the [Adjust Stack Size] dialog box .
Reset Function	Cancels the adjustments to the selected function.
Reset All Functions	Cancels the adjustments to all the functions

(d) [Help]

stk850 Help	Opens the online help for the stk850.
[About stk850] dialog box	Opens the [About stk850] dialog box .

(2) Tool bar







	Same operation as [File] -[Save Call Chain with Maximum Stack from Selected Function...] Saves the call chain with the maximum stack starting with the selected function, to a file.
	Same operation as [View] -[Recalculate Stack Size] Recalculates the stack size.
	Same operation as [View] -[Stop] Stops the currently running jobs.
	Same operation as [Option] -[[Adjust Stack Size] dialog box] Opens the [Adjust Stack Size] dialog box .
	Same operation as [Help] -[stk850 Help] Opens Help for the stk850.

(3) Tree display area

This area displays the function call tree. Icons are not sortable or movable using drag and drop in this area.

The following icons indicate function conditions (in the order of precedence). For example, the icon of the function, whose stack size was modified and becomes the maximum in the callee functions, is not light blue but red.

Table 14 - 2 Function Icons for stk850

Icon		Description
	Red	Function whose stack size is maximum in the callee functions.
	Light blue	Function whose stack size is changed or to which a callee function is added.
	Green	Recursive function or function in the chain of recursion.
	Yellow	Function whose stack size is not determined.
	White	Other function.
	Task	Task declared with #pragma rtos_tsk.

[Context menu]

[Adjust Stack Size] dialog box	Opens the [Adjust Stack Size] dialog box according to the selected function.
--	--

(4) List display area

This area displays the functions selected in the tree display area and its callee functions in the form of a list. Functions are not movable using drag and drop in this area.

(a) Function

This part displays the function names. Click [Function] to sort the list display areapart in the order of the function names. One or more of the indications below appears depending on the type of function.

<code>[func]</code>	When the file including the definition of the function is unknown, the function name is bracketed.
<code>file.c#func</code>	In the case of a static function, "file-name#function-name" composed of the file name with no paths, #, and the function name appears.
<code>func*</code>	In the case of a recursive function, "*" follows the function name.
<code>func&</code>	When the function contains an indirect function call using a pointer, "&" follows the function name.

(b) Total Stack Size

This part displays the total size of the stack which may be used during the execution of the function, including those of its callee functions. "?" is displayed when the stack size is unknown, and "SIZEOVER" is displayed when the stack size value exceeds the limit value.

Click [Total Stack Size] to sort the list display area in the order of the stack sizes.

The stack size is calculated by the following formula, the frame size + the maximum stack size among those of callee functions + the additional margin. If the function is recursive, the value is then multiplied by its recursion depth.

(c) Frame Size

This part displays the size of the function's own stack frame, excluding those of its callee functions. "?" is displayed when the stack size is unknown, and "SIZEOVER" is displayed when the stack size value exceeds the limit value.

Click [Frame Size] to sort the list display area in the order of the frame sizes.

(d) Additional Margin

This part displays the value to be added to the stack size, which is specified by a user or set automatically by the stk850 if it is a system library function. It is blank if no value is provided. If the function is recursive and specified the recursion depth, the value is also displayed with the prefix "**".

Click [Additional Margin] to sort the list display area in the order of the additional margins.

(e) File

This part displays the name of the C language source file in which the function is defined. It is black if the source file is not found.

Click [File] to sort the list display area in the order of the file names.

[Context menu]

[Adjust Stack Size] dialog box	Opens the [Adjust Stack Size] dialog box according to the selected function
Sort List by	Sorts the list display area according to the selected menu.
Function Name	Sorts the list display area in the order of function names.
Icon Type	Sorts the list display area by icon types
Stack Size	Sorts the list display area in the order of total stack sizes.
Frame Size	Sorts the list display area in the order of frame sizes.
Additional Margin	Sorts the list display area in the order of additional margins.
File Name	Sorts the list display area in the order of file names.

(5) Message display area

This area displays warning messages and the execution status.

[Context menu]

Copy	Copies the selected part to the clipboard.
Clear	Clears the message display area

[Adjust Stack Size] dialog box

This dialog box is used to specify additional stack size information of a function.

Figure 14 - 3 [Adjust Stack Size] Dialog Box

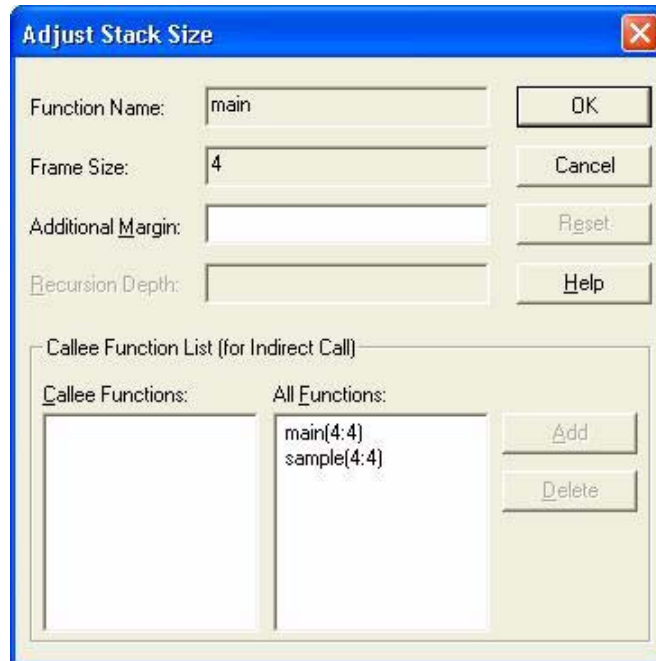

(1) Function Name

This field displays the name of the selected function.

(2) Frame Size

This field displays the size of the function's own stack frame, excluding those of its callee functions. "?" is displayed when the frame size is unknown. "?" is regarded as size 0 in the calculation formula.

(3) Additional Margin

In this field, enter the value that is to be added to the stack size.

- Specify a non-negative decimal number or a hexadecimal number that starts with "0x".
- If this is specified for a function whose stack size is unknown ("?"), the stack size changes from "?" to the following value, (the frame size + the maximum stack size among those of callee functions + the additional margin). If the function is recursive, the value is then multiplied by its recursion depth.

(4) Recursion Depth

In this field, specify the recursion depth, which is the number of times the recursive function is to be called in the recursive call chain. The value should be a positive decimal number or a hexadecimal number prefixed with "0x". The stack size is set to the size multiplied by the specified value.

(5) Callee Function List [for Indirect Call]

(a) Callee Functions

This list shows the functions to be called from the selected function. Added functions are displayed with "+" at the beginning of their names.

(b) All Functions

This list shows the functions defined or called explicitly (not through function pointers) in the registered intermediate assembly language files.

(c) [Add] button

Adds the selected function in the [All Functions](#) to the [Callee Functions](#).

(d) [Delete] button

Deletes the selected function from the [Callee Functions](#). Functions that are explicitly called cannot be deleted.

(6) Other buttons

OK	To save the specification to the stk system file and to close the dialog box.
Cancel	To close the dialog box without saving the specification.
Reset	To cancel all adjustments by the user to the current function.
Help	To open help for the dialog box.

[Stack Size Unknown / Adjusted Function Lists] dialog box

This dialog box shows lists of functions whose stack size is unknown or changed.

Figure 14 - 4 [Stack Size Unknown / Adjusted Function Lists] Dialog Box

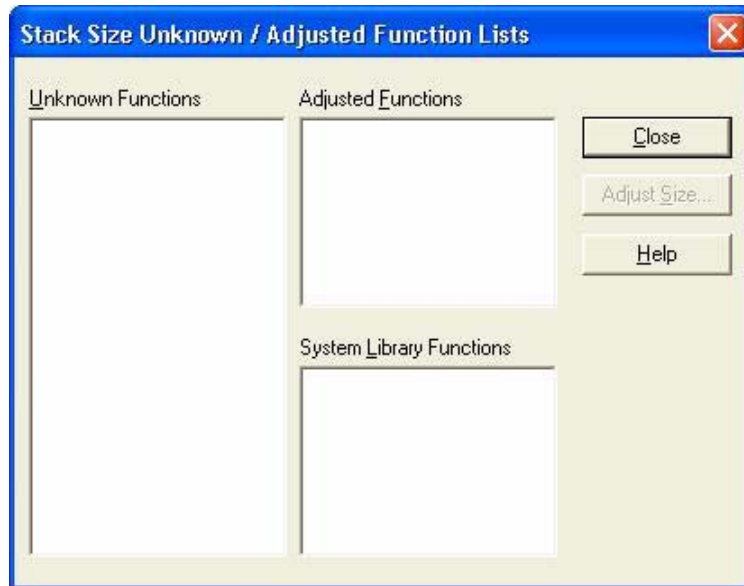

(1) Unknown Functions

This list shows functions whose stack size is unknown and undetermined.

Below are the functions whose stack size is unknown.

- Library functions
- Functions written in assembly language
- Recursive functions
- Functions containing an indirect function call using a function pointer

When the function is a static function, "file-name#function-name" composed of the file name with no paths, #, and the function name is indicated. When the definition file is unknown, "[function-name]" is displayed.

(2) Adjusted Functions

This list shows functions whose stack size/call function has been changed.

A function is displayed in the form of "function name (stack size: frame stack size: change information)". The addition size (+ size) and the recursion count (* count) are displayed as the change information. If a function without change information is displayed, the setting of the call function is changed.

When the function is a static function, its name is displayed in the form of "file-name#function-name", where the file name excludes the path. If the file including the definition of the function is unknown, the function name is bracketed.

(3) System Library Functions

This list shows standard library functions used in the registered intermediate assembly language file. If

"Reset" operations are executed, the stk850 automatically retrieves the predefined setting for these functions. If the stack size information is changed from the default setting, the function is moved to the "[Adjusted Functions](#)".

(4) Other buttons

Close	To close the dialog box.
Adjust Size	To open the [Adjust Stack Size] dialog box for the selected function.
Help	To open the help for this dialog box.

[About stk850] dialog box

This dialog box is used to display the stk850 version information.

Figure 14 - 5 [About stk850] Dialog Box



(1) Button

OK	To close the dialog box.
----	--------------------------

14.5 Cautions

This section describes cautions for the stk850.

14.5.1 Quantitative limit of the stk850

(1) Project file related upper limit values

The upper limit values related to project files are listed below.

Table 14 - 3 Project File Related Upper Limit Values

Item	Limit
Number of files	1
Length of file name	255
Number of characters per line	5119
Number of lines per line	2097152

(2) Intermediate assembly language related upper limit values

The upper limit values related to intermediate assembly language files are listed below.

Table 14 - 4 Intermediate Assembly Language File Related Upper Limit Values

Item	Limit
Number of files	2048
Length of file name	255
Length of symbol name	1022
Number of characters per line	5119
Number of lines per file	65535

(3) Stack size specification file related upper limit values

The upper limit values related to stack size specification files are listed below.

Table 14 - 5 Stack Size Specification File Related Upper Limit Values

Item	Limit
Number of files read simultaneously	1
Length of file name	255
Number of characters per line	5119
Number of functions specified in one line	1
Number of parameters specified for one function	1024
Number of lines per file	32767
Number of functions registered	32767

(4) Output file related upper limit values

The upper limit values related to output files are listed below.

Table 14 - 6 Output File Related Upper Limit Values

Item	Limit
Length of file name	255
Number of characters per line	5119
Number of lines per file	32767

(5) Stack size related limit

The limits related to stack sizes are listed below.

Table 14 - 7 Stack Size Related Limit

Item	Limit
Number of parameters	1 - 1024
Value of additional margin	0 - 2147483647
Value of recursion depth (after multiplication with the stack size)	0 - 2147483647
Value of stack size	2147483647

(6) Message display area

The upper limit values in the message display area are listed below.

Table 14 - 8 Upper Limit Values in Message Display Area

Item	Limit
Number of characters per line	5119
Number of lines	32767

14.6 Output File Formats

This section describes the formats of the following output files.

- [Output result files](#)
- [Stack size specification file](#)
- [stk system file](#)

14.6.1 Output result files

There are two choices of output level, either all the call chains or the chain with maximum stack.

- In the [Main window](#), select [\[File\] - \[Save All Call Chains from Selected Function...\]](#) to output the stack size information of all the call chain starting with the selected function.
- In the [Main window](#), select [\[File\] - \[Save Call Chain with Maximum Stack from Selected Function...\]](#) to output the stack size information of only the call chain, for which stack size is maximum, starting with the selected function.

In both the case, the output format can also be chosen from text or CSV, by specifying the file type in the [\[Save As\]](#) dialog box. By default, the text format is selected.

(1) Text format

If the text format is selected, the result is output in the form of call tree. If there are multiple callee functions, "+--" is placed between the caller and the callee. If there is only one callee, "---" is placed.

Each line can contain up to 5119 characters; the 5120th and subsequent characters are displayed in a new line. The maximum number of output lines is 32767. If there are 32768 lines or more, a warning message is displayed, and output is aborted.

Information of each function is output in the following format. Parameters in brackets are not output if unnecessary.

- [Function](#)[\[Auxiliary Mark\]](#) ([Total Stack Size](#), [Frame Size](#)[\[](#), [Adjustment Information](#)])

Table 14 - 9 Description for Each Parameter

Parameter	Description
Function	This parameter indicates the function name defined in the C language source. If the corresponding C source file is not found, the name is bracketed, or in the form of "[Symbol]", where Symbol is the symbol name in the intermediate assembly language file from which the prefix "_" removed. When the function is a static function, the function name is preceded with the file name (without path) and "#", or "file-name # function-name".

Table 14 - 9 Description for Each Parameter

Parameter	Description
Auxiliary Mark	As shown below, there are two auxiliary marks to indicate that the feature of the function. "*" : Recursive function "&" : Function with a indirect call using a function pointer To specify a certain function name as a candidate for the callee of the indirect call, use " Callee Function List [for Indirect Call] " in the [Adjust Stack Size] dialog box . The specified function is treated as the same as functions which are called directly.
Total Stack Size	This parameter indicates the maximum size of the stack which may be used during the execution of the function. The formula for calculating the total stack size is as follows: (frame size + maximum stack size among those of the callees + additional margin) * recursion depth "?" is output if the stack size is unknown, and "SIZEOVER" is output if the stack size exceeds the limit.
Frame Size	A frame size is the size of the function's own stack frame, excluding those of its callee functions. If the size is unknown, "?" is output.
Adjustment Information	This parameter indicates additional information about stack size specified to the function. It is either or both of the additional margin (+size) and the recursion depth (*time).

Table 14 - 10 Output Format and Content of Adjustment Information

Output Format	Description
+size	"size" is the " Additional Margin " in [Adjust Stack Size] dialog box or the size specified with "ADD=" in the stack size specification file, and shown in the form of a decimal number.
*time	"time" is the recursion depth of a recursive function. It is the " Recursion Depth " in the [Adjust Stack Size] dialog box or the value specified with "RECTIME=" in the stack size specification file, and shown in the form of a decimal number.

(a) Example in which all the call chains are output

```
main(800, 80) +--sub1(720, 240) ---sub2(480, 200) +--sub3(280, 280)
|
|                                     +--sub31(160, 160)
+--sub11*(500, 30, +20*10) ---sub11*(500, 30, +20*10)
+--sub12&(400, 200) ---sub21(200, 200)
+--f.c#sub13(300, 250, +50)
+--sub14(50, ?, +50)
+--sub15(?, ?)
```

(b) Example in which the call chain with the maximum stack is output

```
main(800, 80) ---sub1(720, 240) ---sub2(480, 200) ---sub3(280, 280)
```

(2) CSV format

If the CSV format is selected, the content is the same as that in the text format but in the following form, where a call chain is composed of function names, each element of their information separated by ",". Unlike the text format, however, the CSV format outputs a warning message without starting a new line when the number of characters per line or the number of lines exceeds the limit, and output is aborted.

Information of each functions is output in the following format.

- **Function**[Auxiliary Mark],**Total Stack Size**, **Frame Size**, **Adjustment Information**

The content of each parameter is the same as in the [Text format](#). In the case of the CSV format, however, "0" is output for the adjustment information of functions to which no additional information is specified.

(a) Example in which all the call chains are output

```
Function,Total Stack Size,Frame Size,Adjustment Information
main, 800, 80, 0, sub1, 720, 240, 0, sub2, 480, 200, 0, sub3, 280, 280, 0
main, 800, 80, 0, sub1, 720, 240, 0, sub2, 480, 200, 0, sub31, 160, 160, 0
main, 800, 80, 0, sub11*, 500, 30, +20*10, sub11*, 500, 30, +20*10
main, 800, 80, 0, sub12&, 400, 200, 0, sub21, 200, 200, 0
main, 800, 80, 0, f.c#sub13, 300, 250, +50
main, 800, 80, 0, sub14, 50, ?, +50
```

(b) Example in which the call chain with the maximum stack is output

```
Function,Total Stack Size,Frame Size,Adjustment Information
main, 800, 80, 0, sub1, 720, 240, 0, sub2, 480, 200, 0, sub3, 280, 280, 0
```

14.6.2 Stack size specification file

A stack size specification file is a text files (with an extension ".txt") for collectively specifying information about stack sizes for functions (e.g. functions written in assembly language, library functions, functions that include a indirect call and recursive functions) whose stack sizes cannot be obtained from intermediate assembly language files.

(1) Reading a stack size specification files

The method for reading a stack size specification files is as follows.

- Select [File] - [Load Stack Size Specification File...]

After a file is read, the stack size is recalculated to reflect the information. If some adjustment information has already specified, it is overwritten and read information becomes valid.

(2) Saving a stack size specification files

The method for saving a stack size specification files is as follows.

- Select [File] - [Save Stack Size Specification File...]

The specified information and information abouton undetermined functions, or functions whose stack sizes are not determined are saved to a file. For a undetermined function, only the function name is output.

(3) Format of at stack size specification files

The format of a stack size specification file is composed the function name and each of the parameter separated with ",".

White spaces (spaces and tabs) are not regarded as delimiters. Only the spaces immediately before and after "," are ignored; spaces cannot be placed before and after "=".

In one line, information for one function can be specified. A line starting with "#" is regarded as a comment line, and blank lines are ignored. If only a function name is specified, nothing happens.

- `Function[, ADD=size][, RECTIME=time][, CALL=func]`

Table 14 - 11 Description for Each Parameter

Parameter	Description
Function	This parameter specifies the name of a function whose stack size to be adjusted, in the same form as displayed by the stk850 or in the form of a symbol name in intermediate assembly language source. The name displayed by the stk850 is a function name defined in C language source files. If the C source file which includes the definition of the function is not found, e.g. in the case that the function is written in assembly language or a library function, the function name is placed in brackets. If the function is a static function, the function name is preceded with the file name (without path) and "#", or "file-name#function-name"
ADD=size	This parameter specifies the value to be added to the stack size analyzed by the stk850. For <i>size</i> , specify a non-negative decimal number or a hexadecimal number that starts with "0x". The value is added to the stack size. If 0 is specified for a function whose stack size is unknown, the result of calculation does not change but the function becomes the same as to have the stack whose size is 0.

Table 14 - 11 Description for Each Parameter

Parameter	Description
RECTIME= <i>time</i>	This parameter specifies recursion depth, which is the number of times the function is to be called in a recursive call chain, for a recursive function. For <i>time</i> , specify a positive a decimal number or a hexadecimal number that starts with "0x". The stack size is multiplied by the value (<i>time</i>).
CALL= <i>func</i>	This parameter specifies an additional callee function. Specify a function name as <i>func</i> . The form of the function name is the same as for the "Function" parameter. The specified function is added to the callee functions. Up to 1024 function names can be specified, but the only function with maximum stack makes sense.

Examples of a stack size specification file and output before/after a stack size specification file is read are shown below.

(a) Example of a stack size specification file

```
# sample.txt
# Specify 50 as the stack size of "_flib".
[flib], ADD=50
# Set 0 to the stack size of "_flib_zero".
# The purpose is to make "_flib_zero" not unknown.
[flib_zero], ADD=0
# Add 10 (in hexadecimal) to stack size and specify
# recursion depth (3 times).
sub2, ADD=0xa, RECTIME=3
# Append "sub4" and "_flib" to the callee functions
# called through function pointer
sub3, CALL=sub.c#sub4, CALL=[flib]
# Specify nothing.
sub.c#sub4
```

(b) Output image before stack size specification file is read

```
main(310, 100)---sub1(210, 200)---sub2*(10, 10)---sub2*(10, 10)
      +---sub3&(200, 200)---[flib_zero](?, ?)
      +---sub.c#sub4(50, 50)---[flib](?, ?)
task1(100, 100)---[_cre_tsk](0, 0)
```

(c) Output image after stack size specification file (sample.txt) is read

```
main(400, 100)---sub3&(300, 200)---sub.c#sub4(100, 50)---[flib](50, ?, +50)
      |
      |           +---[flib](50, ?, +50)
      |           +---[flib_zero](0, ?, +0)
      +---sub1(260, 200)---sub2*(60, 10, +10*3)---sub2*(60, 10, +10*3)
      +---sub.c#sub4(100, 50)---[flib](50, ?, +50)
task1(172, 100, +72)---[_cre_tsk](0, 0)
```

The followings are incorrect specifications for stack size information. If the number of lines in a file exceeds the limit, a dialog box appears and an error message is output to the dialog box and the message display area, then the reading operation is aborted.

- limit value, e.g. the number of lines in a file, characters per line, the length of a function name, the number of parameters for one function, and the value of the stack size, is exceeded
- When function names that are not defined or called explicitly in C source are specified
- When multiple specifications for one function exists in a file
- When an argument is not specified for ADD, RECTIME, or CALL
- When there is any other parameter than ADD, RECTIME, and CALL
- When an incorrect argument (other than decimal numbers and hexadecimal numbers that starts with "0x") is specified for ADD or RECTIME
- When an incorrect argument (function name) is specified for CALL
- When RECTIME is specified for a non-recursive function
- When multiple function names are specified for onea CALL

14.6.3 stk system file

The stk system file is a file for saving stack size adjustment information, and it is read and saved automatically by the stk850.

The file name is "project file name .psg", and the format is the same as that of stack size specification files. However, the information to be saved is limited to those of functions whose size has been changed.

Caution Even though the stk system file is a text file, it must not be modified.

APPENDIX A FORMAT OF OBJECT FILE

This appendix describes the format of the object file used with the CA850 compiler package.

A.1 Structure of Object File

The format of the object file used with the CA850 compiler package conforms to the ELF format, a standard object file format.

The structure of an object file in this format differs somewhat between relocatable object files and executable object files (refer to [Figure A - 1](#)). A relocatable object file contains the information that is needed to create an executable object file, and an executable object file contains the information needed to execute the object file.

The following sections describe the ELF header, program header table, section header table, section, and segment, which are constituent elements in ELF-format object files.

Figure A - 1 Object File Structures

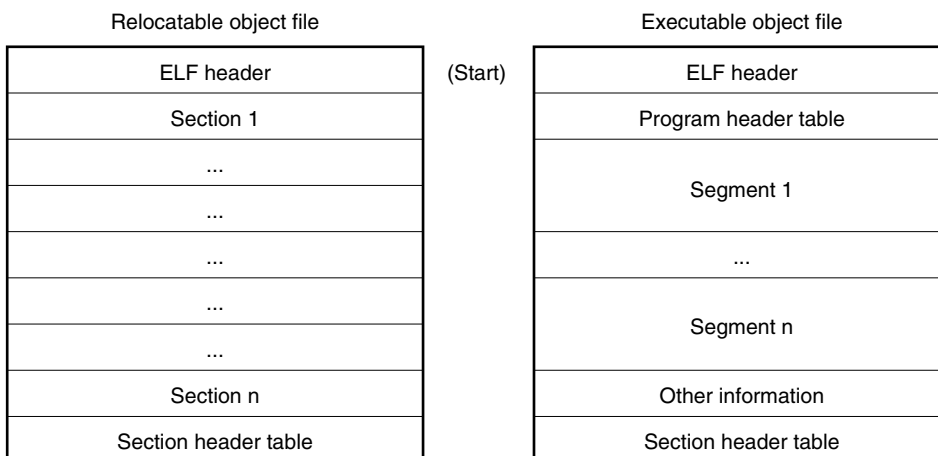

A.2 ELF Header

This section describes the ELF header, which is a constituent element in ELF-format object files.

The ELF header is at the start of the object file and contains the information needed to interpret the object file or to access the other constituent elements in the object file (refer to [Table A - 1](#)).

Table A - 1 Constituent Elements of ELF Header and Their Meanings

Constituent Elements	Meaning
ident[CLASS]	Class of this object file
ident[DATA]	Byte order of data in this object file (2MSB if big endian or 2LSB if little endian)
type	Type of this object file
machine	Target processor of this object file
version	Version number of this object file
entry	Entry point address
phoff	Offset in file of program header table
shoff	Offset in file of section header table
flags	Unique flag for processor that this object file runs on
ehsize	Byte size of this ELF header
phentsize	Size of program header table entry
phnum	Number of program header table entries
shentsize	Size of section header table entries
shnum	Number of section header table entries
shstrndx	Section header table index of string table .shstrtab that contains the section name

A.3 Program Header Table

This section describes the program header table, which is a constituent element in ELF-format object files.

The program header table is an array of program header table entries that contain information about all the segments included in the object file (refer to [Table A - 2](#)).

An index (i.e. a subscript) to this array is called a program header table index, which is used to reference the program header table entries.

Table A - 2 Constituent Elements of Program Header Table Entries and Their Meanings

Constituent Element	Meaning
type	Segment type of corresponding segment (type is LOAD if segment is loaded to memory, or NOTE if segment has auxiliary information)
offset	Offset in file of corresponding segment
vaddr	Virtual address of corresponding segment
paddr	Physical address of corresponding segment
filesz	Size of corresponding segment in file ^{Note}
memsz	Size of corresponding segment in memory
flags	Segment attribute of corresponding segment (attribute is R for segment that can be read, W for segment that can be written, or X for executable segment)
align	Alignment condition of corresponding segment

Note If a section having section type NOBITS (section not having an actual value in the object file) is allocated to the corresponding segment, a value other than the memsz value is set.

A.4 Section Header Table

This section describes the section header table that is a constituent element in ELF-format object files.

The section header table is an array of section header table entries that contain information about all of the sections included in the object file (refer to [Table A - 3](#)). An index (i.e. a subscript) to this array is called a section header table index, which is used to reference the section header table entries.

Table A - 3 Constituent Elements of Section Header Table Entries and Their Meanings

Constituent Element	Meaning
name	Name of corresponding section (index to string table .shstrtab that contains the section name)
type	Section type of corresponding section (refer to " A.4.1 Section types ").
flags	Section attribute of corresponding section (attribute is A for a section occupying memory, W for a section that can be written, X for an executable section, and G for a section that is allocated to a memory range that can be referenced using global pointer (gp) with 16-bit displacement)
addr	Start address of corresponding section
offset	Offset in file of corresponding section
size	Size of corresponding section
link	Section header table index link of corresponding section (refer to " A.4.2 Constituent elements (link/info) dependent on section type ").
info	Information dependent on section type of corresponding section (refer to " A.4.2 Constituent elements (link/info) dependent on section type ").
addralign	Alignment condition of corresponding section
entsize	Size of entries in corresponding section

A.4.1 Section types

The section types indicated by the constituent element *type* in the section header table are shown with an explanation of their meanings in the following table.

Table A - 4 Section Types and Their Meanings

Section Type	Meaning
GPTAB	Global pointer table (size with first entry aligned with num of -Gnum specified for compiler and assembler and entries 0, 2 and subsequent entries aligned with data size and word units)
NOBITS	Section for data that does not have an actual value in the object file (e.g., data for which no initial value is specified)
PROGBITS	Section for data that has an actual value in the object file (e.g., data for which a machine language instruction or initial value has been specified)
REGMODE	Section existing in relocatable object file created using the register mode function ^{Note} (stores information on the number of registers internally used by the ca850)
REL (not supported)	Relocation information
RELA	Relocation information
SYMTAB	Symbol table (refer to A.4.1).
STRTAB	String table (refer to A.4.2).

Note Refer to the explanation of the CA850's -reg option.

A.4.2 Constituent elements (link/info) dependent on section type

The meanings of the section header table's constituent elements link and info, which are dependent on section type *type*, are shown in [Table A - 5](#).

Table A - 5 Meanings of Link and Info

Section Type	Meaning of Link	Meaning of Info
GPTAB	---	Section header table index of section to which corresponding data is allocated
REL (not supported)	Section header table index of corresponding symbol table	Section header table index of section to be relocated (This section type is not supported in the CA850 compiler package.)
RELA	Section header table index of corresponding symbol table	Section header table index of section to be relocated
SYMTAB	Section header table index of corresponding string table	Symbol table index of symbol that appears first when table is not local

A.5 Sections

The following describes the sections that are constituent elements in ELF-format object files.

A section is a main constituent element of object files. Its contents include machine language instructions, data, symbol tables, string tables, debug information, and line number information.

A section must meet the following conditions.

- (1) One section header table entry corresponding to the section header table must exist in each section.
- (2) In some cases (such as a section having section type NOBITS), a section may have only a section header table entry but no actual value exists in the object file.
- (3) A section that has an actual value in the object file occupies a contiguous area in the object file.
- (4) Sections do not share an area in the object file. In other words, there is no area that belongs to more than one section.

A.5.1 Symbol table

The following describes the symbol table, a type of section.

The symbol table, a section of section type SYMTAB, is an array of symbol table entries containing information about all of the symbols included in the object file (refer to [Table A - 6](#)). An index (i.e. a subscript) to this array is called a symbol table index, and the symbol table entries are referenced using this symbol table index^{Note}.

Note An entry with symbol table index 0 is reserved, and each constituent element's value is 0.

Table A - 6 Constituent Elements of Symbol Table Entries and Their Meanings

Constituent Element	Meaning
name	Name of corresponding symbol (index to string table .strtab)
value	Value of corresponding symbol
size	Size of corresponding symbol
BIND (info)	Binding class of corresponding symbol (binding class is GLOBAL for a symbol used to resolve an external reference or LOCAL for a symbol not used to resolve an external reference)
TYPE (info)	Type of corresponding symbol (type is FILE for a normal file name, FUNC for a function name, NOTYPE for an undefined symbol, OBJECT for a symbol indicating a normal label, SECTION for a section name, or DEVFILE for a device file name)
other	---
shndx	Section header table index of section for corresponding symbol (which takes one of the following values: ABS for a symbol indicating a constant, COMMON for an undefined external symbol that is referenced using a global pointer (gp) with 32-bit displacement, GPCOMMON for an undefined external symbol that is referenced using a global pointer (gp) with 16-bit displacement, or UNDEF for an undefined symbol)

A.5.2 String table

The following describes the string table, a type of section.

The string table, a section of section type STRTAB, consists of a character string that ends with a null character (\0). This character string is referenced using an index that is an offset from the beginning of the string table^{Note} (refer to [Table A - 7](#)).

An ELF-format object file uses this character string to hold the names of symbols and sections. For example, the constituent element *name* in the section header table entry has an index to the string table .shstrtab which holds a section name.

Note The rule is that the first byte expressed by index 0 is a null character.

Table A - 7 Relationship Between Indexes and Character Strings in String Table

Index	+0	+1	+2	+3	+4	+5	+6	+7	+8	+9
0	\0	n	a	m	e	.	\0	V	a	r
+10	i	a	b	l	e	\0	a	b	l	e
+20	\0	\0	x	x	\0					

Index	String
0	null string
+1	name.
+7	Variable
+11	able
+16	able
+24	null string

A.5.3 Reserved sections

In ELF-format object files, several sections are reserved as reserved sections.

The following table lists the names, section types, and section attributes of these reserved sections

Table A - 8 Reserved Sections

Name ^{Note 1}	Description	Section Type	Section Attribute
.az_info_j .az_info_r .az_info_ri	Information section for AZ850	PROGBITS	None
.bss	.bss section	NOBITS	AW
.const	.const section	PROGBITS	A
.data	.data section	PROGBITS	AW
.ext_info	Information section for flash/external ROM re-link function	PROGBITS	None
.ext_table	Branch table section for flash/external ROM re-link function	PROGBITS	AX
.ext_tgsym	Information section for flash/external ROM re-link function	PROGBITS	None
.gptabname	Global pointer table ^{Note 2}	GPTAB	None
.pro_epi_runtime	Prologue/epilogue run-time call section	PROGBITS	AX
.regmode	Register mode information	REGMODE	None
.relname	Relocation information	REL	None
.relaname	Relocation information	RELA	None
.sbss	.sbss section	NOBITS	AWG
.sconst	.sconst section	PROGBITS	A
.sdata	.sdata section	PROGBITS	AWG
.sebss	.sebss section	NOBITS	AW
.sedata	.sedata section	PROGBITS	AW
.shstrtab	String table containing section names	STRTAB	None
.sibss	.sibss section	NOBITS	AW
.sidata	.sidata section	PROGBITS	AW
.strtab	String table	STRTAB	None
.symtab	Symbol table	SYMTAB	None
.text	.text section	PROGBITS	AX
.tibss	.tibss section	NOBITS	AW
.tibss.byte	.tibss.byte section	NOBITS	AW
.tibss.word	.tibss.word section	NOBITS	AW
.tidata	.tidata section	PROGBITS	AW

Table A - 8 Reserved Sections

Name ^{Note 1}	Description	Section Type	Section Attribute
.tidata.byte	.tidata.byte section	PROGBITS	AW
.tidata.word	.tidata.word section	PROGBITS	AW
.vdbstrtab	Symbol table for debug information	STRTAB	None
.vdebug	Debug information	PROGBITS	None
.version	Version information section	PROGBITS	None
.vline	Line number information	PROGBITS	None

Notes 1 The name part of .gptabname, .relname, and .relaname indicates the name of the section corresponding to each respective section.

2 This is information that is used when processing the linker's -A option.

APPENDIX B MESSAGE

This appendix describes the messages used in the CA850.

B.1 Output Message

This section describes the messages output by the CA850.

B.1.1 Message format

[Example]

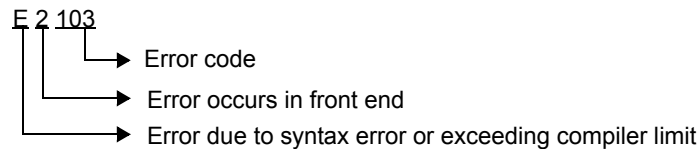

The name of the module responsible for the error is appended to the message output by the ca850. If the file name or line number where the error occurred can be identified, it is appended also along with a message number.

The message number indicates the level of the error that has occurred and the module in which the error occurred.

The initial character of a message number, which indicates the error level, has one of the following meanings:

C ... Internal error.

Compilation is always stopped.

E ... Error due to syntax error or over compiler limit.

If errors of this type occur beyond the specified number, compilation is stopped.

[Example]

Undefined variable

F ... Fatal error.

Compilation is always stopped.

[Example]:

Insufficient memory

W ... Warning.

Compilation continues.

[Example]

A variable is referenced before a value is assigned to it.

The number following the above-mentioned characters indicates the module where the error occurred.

1	CA850 driver module (ca850)
2	front end (cafe)
3	Assembler (as850)
4	Linker (ld850)
5	global optimization module (opt)
6	code generation module (cgen) [6000 - 6499] machine-dependent optimization module (impr) [6500 - 6999]
7	pre-optimizer (popt)
8 -	Others

B.1.2 Compiler

Cxxxx: Internal error (xxxx indicates the number of the error.)

Check that this is not a restriction. If not, contact NEC Electronics Technical Support.

E1305: cannot remove temporary directory '*dir*'

The work folder *dir* prepared for creating a temporary file cannot be deleted.

E1307: cannot unlink temporary file '*file*'

Temporary file *file* cannot be deleted.

E2043: illegal argument for function

The argument of function *function* is illegal.

E2103: illegal header name

The character string of the header name specified by #include is incorrect.

E2104: cannot find include file '*file*'

The file *file* specified by the #include directive cannot be found.

E2111: illegal token '*token*'

An illegal token *token* is recognized.

E2113: unexpected EOF

The file ends at a position not permitted by syntax.

E2114: non-terminated comment

"/" that closes the comment is missing.

E2116: illegal expression syntax

The description of the expression in preprocessing control is incorrect.

E2117: compiler limit: too long identifier '*name...*' [*num*]

The identifier *name* is too long. The maximum value for this processing system is 1023 for the internal identifier and 1022 for the external identifier.

E2118: compiler limit: too many characters in string literal [*num*]

The character string literal is too long. The maximum value for this processing system is 4045.

E2123: compiler limit: too many macro parameters [*num*]

Too many macro parameters are used. The maximum value for this processing system is 127.

E2124: illegal macro name '*name*'

The macro name *name* is incorrect.

E2125: System reserved macro '*name*' must not be redefined.

The macro *name* must not be redefined because it is reserved for the system.

E2126: System reserved macro '*name*' must not be undefined.

A macro *name* definition reserved for the system cannot be canceled.

E2129: illegal macro parameter '*name*'

The macro's parameter *name* is incorrect.

E2130: macro '*name*': mismatch number of parameters

The number of parameters of macro *name* does not match.

E2131: macro '*name*': missing ')'

")" is missing from the macro *name* definition that has a parameter.

E2133: illegal operand for '#' operator

Something other than a parameter is specified for the '#' operator in a macro definition.

E2134: compiler limit: too long stringizing result [*num*]

The character string is too long. The maximum value for this processing system is 32766.

E2135: illegal operand for '##' operator

The description of token concatenation in this macro definition is incorrect.

E2136: illegal pasting result

The result of token concatenation is incorrect.

E2137: compiler limit: too long pasting result [*num*]

The result of token concatenation is too long. The maximum value for this processing system is 32766.

E2138: macro '*name*' illegal parameter syntax

The parameter of macro *name* is incorrect.

E2151: illegal preprocessing directive syntax

The description of the preprocessing directive contains an error.

E2152: illegal number '*name*' in conditional inclusion.

name that is not an integer must not be specified in an expression following #if.

E2155: compiler limit: too many conditional inclusion nestings [*num*]

The number of nesting levels between "#if" and "#endif" exceeds the limit. The maximum value for this processing system is 255.

E2156: misplaced '#else' or '#elif'

The position of "#else" or "#elif" is inappropriate.

E2157: misplaced '#endif'

The position of "#endif" is inappropriate.

E2159: illegal include directive syntax

The description of "#include" is incorrect.

E2164: unexpected non-whitespace before preprocessing directive

A character other than a blank character exists before the preprocessing command.

E2165: unrecognized pragma directive '#pragma *directive*', ignored

#pragma *directive* is not recognized. This pragma directive is ignored.

E2170: illegal integral/floating constant

The notation of the integer/floating-point constant is incorrect.

E2171: constant out of range

The specified constant value exceeds the specifiable range.

E2173: illegal octal digit

The coding of an octal number contains an error.

E2174: illegal hexadecimal digit

The coding of a hexadecimal number contains an error.

E2175: octal digit out of range

The specified octal number exceeds the specifiable range.

E2177: empty character constant

The character constant is vacant.

E2178: illegal binary digit

The coding of a binary number contains an error.

E2210: *name*: not defined

name is not defined.

E2211: redeclaration of *name*

name has been redeclared.

E2213: Nothing is declared.

No declarator is specified.

E2214: Void object is not allowed.

void object is not allowed.

E2217: Undeclared function '*function*' is called.

Function *function* without declaration has been called.

E2220: Both 'signed' and 'unsigned' are specified.

Both "signed" and "unsigned" have been specified.

E2221: illegal type specifier combination

The combination of type-specifiers is incorrect.

E2236: Typedef declaration must not have initializer.

The typedef declaration cannot include an initializer.

E2237: too many initializers

Too many initializers are used.

E2238: illegal initializer

The initializer is incorrect.

E2240: Local static function is not allowed.

A static function cannot be declared in the local scope.

E2250: Array size is not given.

The size of the array is not given.

E2251: Array size must be greater than zero.

The size of the array must be greater than zero.

E2252: Array type has incomplete element type.

The type of the array element is incomplete.

E2253: compiler limit: array size is too large [0xffffffff]

The size of the array is too large. Maximum value is 0xffffffff.

E2260: compiler limit: complicated type modifiers [num]

Too many derivative modifiers are used. The maximum value for this processing system is 16.

E2261: illegal storage class specifier combination

The combination of storage class specifiers is incorrect.

E2262: illegal use of 'enum'

The type specifier "enum" is used incorrectly.

E2263: illegal use of 'struct'

The type specifier "struct" is used incorrectly.

E2265: illegal use of 'union'

The type specifier "union" is used incorrectly.

E2266: illegal use of '*specifier*'

The storage area class specifier "*specifier*" is used incorrectly.

E2274: illegal use of 'typedef'

The storage area class specifier "typedef" is used incorrectly.

E2280: Void function cannot return value.

A return value is specified for a void type function.

E2281: Function has illegal storage class.

The storage class specified for the function is incorrect.

E2282: Array of function is not allowed.

An array of functions is not allowed.

E2283: illegal return type: function

The return value of a function must not be used as a function type.

E2284: illegal return type: array

The return value of a function must not be used as an array type.

E2285: 'Void' in parameter list

The void type is specified within the arrangement of the argument declaration of the function declaration.

Only one void type can be used.

E2286: Function requires return value.

No return value is specified for a function having a return value.

E2288: return type mismatch *type1* (*type2*)

The type of return value *type2* indicated by the return statement does not match return type *type1* of the function.

E2290: argument type mismatch *type1* (*type2*)

The type of actual argument *type2* does not match the type of dummy argument *type1* at the time of the function declaration.

E2292: Argument *name* is missing.

Dummy argument name *name* declared in the function definition cannot be found.

E2296: illegal first argument '...', requires a named argument

"..." cannot be used as the first argument of a function.

E2300: 'Struct'/'union' size must not be zero.

The size of a structure/union must not be zero.

E2301: illegal bit-field type

A type which must not be specified for a bit field has been specified.

E2303: illegal bit-field size

The value of a constant expression that specifies the width of a bit field must not exceed the number of bits constituting the object of the specified type.

E2304: '*name*' has incomplete type.

The type of *name* is incomplete.

E2305: Field '*name*' declared as a function.

The type of member *name* is a function type.

E2347: Local extern '*symbol*' is put into the next unit.

The externally linked declarator *symbol* was initialized by the local scope.

E2349: Initialization of non-auto pointer using non-number initializer is not position independent.

The code for an initialization command using a default value other than the value of a pointer variable other than an automatic variable is not position-independent.

E2361: New style function definition has old style parameter declaration(s).

An old argument declaration format is used in a new function definition format.

E2374: The bit-field object '*name*' is put into the next unit.

Bit field *name* is located in the next field because it exceeds the boundary.

E2401: syntax error

The syntax is incorrect.

E2402: Label '*label*' not defined

The label *label* is not defined.

E2411: label is not in switch

The case label or default label is missing from the switch statement.

E2412: duplicate '*case num:*' in switch

The case label *num* in the switch statement is duplicated. *num* may be expanded as a numeric value.

E2413: duplicate '*default:*' in switch

The default label is duplicated in the switch statement.

E2414: '*break*' not in loop nor switch

"break" is outside an iteration statement or a switch statement.

E2415: '*continue*' not in loop

"continue" is outside an iteration statement.

E2420: argument *num* expected for function call *function*

The argument following *num* is not specified in function call *function*.

E2421: unexpected argument *num* for function call *function*

An excess argument is specified after *num* in function call *function*.

E2422: undefined static function '*function*'

The called static function *function* is not defined in a file.

E2510: cannot cast: *type1* to *type2*

Casting from *type1* to *type2* cannot be executed.

E2511: *expression* must be arithmetic or pointer type.

Specify *expression* as arithmetic or pointer type.

E2512: *expression* must be arithmetic type.

Specify *expression* as arithmetic type.

E2513: *expression* must be pointer type or zero.

Specify *expression* as pointer type or zero.

E2515: *expression* must be integral type.

Specify *expression* as integer type.

E2516: *expression* must be constant expression.

Specify *expression* as a constant expression.

E2517: One of the operands for '[' must be pointer type and the other must be of integral type.

One of the operands for '[' must be of pointer type and the other must be of integer type.

E2518: illegal operand for unary '&'

The operand of the unary operator "&" is incorrect.

E2519: *exception* has occurred at compile time.

The exception *exception* related to floating-point operation occurred at compile time.

E2522: *name* is not a member.

name is not a member of an aggregate.

E2523: illegal LHS of '*operator*' operator(must be modifiable Lvalue)

An illegal substitution destination is coded to the left of operator *operator*.

E2524: illegal type combination for '*operator*' (*type1*, *type2*)

The combination of types for the operator *operator* (*type1* and *type2*) is incorrect.

E2526: Operands of '*operator*' operator must have same type(*type1*, *type2*).

Use the same type (*type1* and *type2*) for the right and left of the operator *operator*.

E2529: invalid use of void expression

The void expression is incorrect.

E2530: Operand of '()' must be function type.

The operand of the "()" operator must be a function.

E2532: Operand of '*operator*' must be pointer type.

The operand of the operator *operator* must be of pointer type.

E2533: Operand of '.' must be 'struct'/'union' object.

Use the "." operator for a structure or union.

E2535: Operand of '`->`' must be pointer to '`struct`'/'`union`' object.

Use the "`->`" operator for the pointer to a structure or union.

E2550: Operand of '`sizeof`' must not be type.

The operand of "`sizeof`" cannot specify type.

E2551: unknown size('struct', 'union' or array

An aggregate with unknown size is specified for an operator that requires an object size.

E2552: unknown size(*function*)

A *function* with unknown size is specified for an operator that requires an object size.

E2553: cannot convert non-Lvalue array to pointer

An array which is not a left-side value cannot be converted into a pointer.

E2556: unknown size('enum')

An enumerator with unknown size is specified for an operator that requires an object size.

E2630: unrecognized interrupt request name '*name*'

An illegal interrupt request is specified by the `#pragma` directive.

E2631: Interrupt request name '*name*' is already specified.

The interrupt request name *name* has already been specified.

E2632: illegal directive '`#pragma directive`', function name must be specified

A function name is required for the directive `#pragma directive`.

E2633: cannot specify interrupt attribute '`direct`', function '*function*' is already defined.

An interrupt handler cannot be directly located and specified after function definition.

E2636: Multiple interrupt request names are specified for function '*function*', '`direct`' cannot be specified.

Two or more interrupt requests are specified for function *function*. Direct location (`direct`) cannot be specified for a function for which two or more interrupts are specified.

E2638: Interrupt function must be void type.

The return type of a function declared as an interrupt must be of void type.

E2639: illegal function type for software interrupt function, must be void(unsigned int).

A function declared as a software exception interrupt (trap interrupt) can only have one unsigned int type as the argument.

E2640: illegal function type for interrupt function, must be void(void).

A function declared as an interrupt (except software exception) cannot have an argument.

E2641: cannot call interrupt function

A function declared as an interrupt cannot be called.

E2642: Function '*function*' is already defined, 'block_interrupt' must be specified before function definition.

Interrupts cannot be disabled after the function definition.

E2644: Function '*function*' is already defined without '__interrupt'.

Although the function *function* is specified as an interrupt handler, function has been already defined without an interrupt specification.

E2646: Both interrupt and RTOS interrupt attributes are specified.

The normal interrupt and RTOS interrupt must not be specified at the same time.

E2647: Specifying interrupt name '*name*' is not allowed.

RESET and RST must not be specified as an interrupt request *name*.

E2648: unknown cpu type, cannot use interrupt request name

An interrupt request name cannot be used because no device is specified.

E2649: Interrupt function '*function*' with 'direct' is undefined.

Function *function* that is specified to be located directly is not defined in the file.

E2650: illegal directive '#pragma section', section name must be specified

A section name is not specified in section allocation by the #pragma directive.

E2651: illegal directive '#pragma section', unrecognized section name '*name*'

An illegal section name *name* is specified in section allocation by the #pragma directive.

E2652: illegal directive '#pragma section', 'begin' or 'end' must be specified

"begin" and "end" are necessary for section allocation by the #pragma directive.

E2653: Directive '#pragma section' is nested.

Section allocation specification by the #pragma directive is nested.

E2654: inconsistent section for '*symbol*'

The section contradicts the symbol *symbol*.

E2655: misplaced '#pragma section *section* end'

The position of "#pragma section *section* end" is inappropriate.

E2660: cannot write, read only I/O register '*regname*'

Data cannot be written to the internal peripheral function register *regname*, which has only a read attribute.

E2661: cannot read, write only I/O register '*regname*'

Data cannot be read from the internal peripheral function register *regname*, which has only a write attribute.

E2662: cannot access for I/O register bit number '*regname*'

A position that cannot be accessed is specified in the description of the bit access to the internal peripheral function register *regname*.

E2663: I/O register bit number must be integral type.

Describe the specification of the bit position for an internal peripheral function register with an integer value.

E2664: Specifying bit number for I/O register '*regname*' is not allowed.

Bit access cannot be specified for a bit of the internal peripheral function register *regname*.

E2665: unknown cpu type, cannot use I/O register

The internal peripheral function register cannot be used because the target device is unknown.

E2666: illegal operand (I/O register '*regname*') for unary '&'

The address of the internal peripheral function register *regname* cannot be obtained.

E2670: unexpected EOF, missing '#pragma endasm'

Specification of the final assembler insertion cannot be found.

E2681: First argument for `__set_il` is out of range.

The value of an interrupt level exceeds the range that can be specified. An integer of -1 to +8 can be specified as an interrupt level.

E2682: Second argument for `__set_il` must be string literal ("Interrupt Request Name")

Specify a character string indicating an interrupt request name as the second argument of the function that sets an interrupt level.

E2685: illegal argument for `__set_il(int, "Interrupt Request Name")`

The argument of the function that sets an interrupt level contains an error. Specify an integer type as the first argument and an interrupt request name as the second argument.

E2692: Both interrupt attribute and '*rtos_task*' are specified.

An RTOS task and an interrupt cannot be specified for a function at the same time.

E2693: Function '*function*' is already defined, '*rtos_task*' must be specified before function definition.

A function must not be specified as an RTOS task after the function definition.

E2694: Function '*function*' is already defined without '`__rtos_interrupt`'.

Although function *function* is specified as an interrupt handler, function has been already defined without an interrupt specification for RTOS.

E2695: cannot call *rtos_task* function

A function that is specified as an RTOS task cannot be called.

E2696: Rtos system call '*function*' is already defined, cannot specify '`#pragma kind`'

A function having the same name as function *function* has already been defined or declared. The RTOS system call cannot be validated by the pragma specification of the RTOS function.

E2697: Rtos system call '*name*' is called in the function, for which *rtos* interrupt attribute is not specified.

RTOS system call *name* is called by a function for which an RTOS interrupt is not specified. *name* is regarded as a normal function call.

E2698: cannot call `rtos_interrupt` function

A function that is specified as an RTOS interrupt handler cannot be called.

E2701: Duplicated GP symbol for RTOS interrupt function '*function*'

Another gp symbol has already been allocated to function *function* specified as an RTOS interrupt handler.

E2702: Specifying interrupt name '*name*' is not allowed for `rtos_interrupt`.

name must not be specified as an interrupt request name.

E2712: unexpected end-of-line(missing ']')

Enclose a section name in a section file with "[]".

E2713: unexpected character(s) '*token*'

An unnecessary token *token* exists in the section file. Check the format of the section file.

E2714: Variable, function or file name is missing.

The description of the variable information of the section file is illegal.

E2715: illegal function/variable name '*symbol*'

Symbol *symbol* is an illegal function name or variable name.

E2716: Section name is not specified.

A section name is not specified.

E2717: unrecognized section name '*section*'

Illegal section name *section* is specified.

E2746: Too long section name[256]

The section name is too long. Specify the name using no more than 256 characters.

E2747: inconsistent section name for '*symbol*'

The section name contradicts the symbol *symbol*.

E2749: Function '*function*' is already defined without '`__multi_interrupt`'.

Although the function *function* is specified as multiple interrupt function, function has been already defined without a multiple interrupt specification.

E2750: Both interrupt and multi interrupt attributes are specified.

Normal interrupt and multiple interrupt must not be specified at the same time.

E2751: Both RTOS interrupt and multi interrupt attributes are specified.

RTOS interrupt and multiple interrupt must not be specified at the same time.

E2752: cannot call function *function*

Function *function* cannot be called.

E2760: unknown cpu type, cannot use *directive*

directive cannot be used because a target device is not specified.

E2781: result of comparison is always false

The result of the comparison expression is false.

E2783: statement with no effect

There is a statement without meaning.

E2785: Conversion may lose significant digit

The data may be lost.

E7201: multiple defined symbol '*symbol*'

Multiple-defined symbol *symbol* exists.

E7202: redeclaration of '*symbol*'

symbol is redeclared.

E7203: undefined symbol '*symbol*'

symbol is undefined.

E7204: undefined label (*.Lnum*)

The label *.Lnum* is undefined.

E7205: Argument type mismatch is detected where '*caller*' calls '*callee*'.

The argument types of *caller* and *callee* differ during inline expansion.

E7206: Return value type mismatch is detected where '*caller*' calls '*callee*'.

The types of the return values of *caller* and *callee* differ during inline expansion.

E7207: interrupt request '*name*' already specified

Interrupt request name *name* has already been specified.

E7208: inconsistent section for '*symbol*'

The section contradicts symbol.

F1001: out of memory

Memory capacity is insufficient.

F1002: cannot recover from previous errors

Processing cannot continue due an error that occurred previously.

F1102: invalid argument of option '*option*'

The argument of option *option* is illegal.

F1103: nested command file '*file*'

The command file *file* is nested. It must not be nested.

F1104: Argument of -reg option requires 26 or 22.

Specify either 26 or 22 as the argument of the -reg option.

F1105: cannot use '*option1*' option with '*option2*' option

Options *option1* and *option2* must not be specified at the same time.

F1106: cannot specify output file name of -Xcre_sec_data with many source files.

When inputting two or more source files, the output file name of option -Xcre_sec_data must not be specified.

F1107: Register 'rnum' is reserved for compiler system.

Register *rnum* is reserved for the compiler system.

F1202: module: not found

The module *module* that must be started cannot be found.

F1203: module: exec failed

Execution of the module *module* has failed.

F1292: too long argument

Arguments exceeded 128 bytes when starting module. The arguments must be in a command file.

F1302: 'file': illegal output file name

The output file name *file* specified by the -o option must not be the same as an input file name. Change the file name.

F1303: cannot open file 'file'

The file *file* cannot be opened.

F1304: cannot create temporary directory

A working folder for creating temporary files cannot be created.

F1306: cannot open temporary file 'file'

Temporary file *file* cannot be opened.

F1309: 'file': illegal output file name of -Xcre_sec_data

The output file name *file* specified by option -Xcre_sec_data must not be the same as an input file name. Change the file name.

F1310: cannot create directory 'dir'

folder *dir* cannot be created.

F1311: cannot find device file

The device file cannot be found.

F2001: illegal command path

The specified command path is incorrect.

F2002: compiler limit: too long command path [num]

Compiler limit: The length of the specified path exceeds the limit. The maximum value for this processing system is 1024.

F2003: out of memory

The memory capacity is insufficient.

F2004: too many errors

Compiling has stopped because errors exceeding the specified error count have occurred.

F2005: cannot open output file 'file'

Output file *file* cannot be opened.

F2006: cannot open input file '*file*'

Input file *file* cannot be opened.

F2007: cannot write file '*file*' (errno = *num*)

Error of error number *num* occurred during write to file *file*.

F2010: illegal option '*option*'

The specification of option *option* is not correct.

F2011: compiler limit: too many option potions [*num*]

The number of times option *option* is specified exceeds the limit. The maximum value for this processing system is *num*.

F2014: Both '*option1*' and '*option2*' cannot be specified.

option1 and *option2* cannot be specified at the same time.

F2020: compiler limit: scope level too deep [*num*]

The scope level depth exceeds the limit. The maximum depth value for this processing system is 255 levels.

F2040: compiler limit: too many parameters [*num*]

The function has too many dummy arguments. The maximum number of dummy arguments for this processing system is 255.

F2105: compiler limit: too long file name '*file*' [*num*]

The name of the file *file* is too long. The maximum file name length for this processing system is 1024.

F2106: Non empty file must end in new-line character.

A file that is not empty must be terminated with a carriage return.

F2110: unknown character '*character*'

An illegal character *character* is used.

F2112: compiler limit: too many characters in logical source line [*num*]

The number of characters in the logical source line exceeds the limit. The maximum number of characters for this processing system is 32768.

F2115: non-terminated string literal

(") symbol for closing a string literal is missing.

F2119: compiler limit: string buffer overflow [*num*]

Compiler limit: The character string buffer has overflown. The maximum value for this processing system is 32768.

F2120: compiler limit: preprocessor token buffer overflow [*num*]

The length of the expanded character string in the macro definition exceeds the limit (the buffer capacity is *num* characters too small).

[Remark]

This message is output if the length of an expanded character string of a macro definition exceeds the limit. Change the limit value by using the option `-Xmnum` (*num* is 2047 if `-Xm` is omitted. It can be up to 32767 if `-Xmnum` is specified) that increases the upper-limit number of macro definitions. This option increases the size of the buffer used by the preprocessor; it does not specify the exact capacity of a buffer to be secured, such as how many characters.

F2121: compiler limit: too many macro definitions [*num*]

The number of macro definitions exceeds the limit. The maximum number of macro definitions for this processing system is *num*.

F2122: compiler limit: too long macro name '*name*' [*num*]

The length of the macro name *name* is too long. The maximum macro name length for this processing system is 1023.

F2128: redeclared macro parameter '*name*'

The parameter name of a macro is redefined.

F2153: unexpected non-whitespace before preprocessing directive

A character other than a blank character exists before a preprocessing directive.

F2154: undefined control

The description of the preprocessing directive following `"#"` is incorrect.

F2158: compiler limit: too many include nestings [*num*]

The number of nesting levels in the `#include` directive exceeds the limit. The maximum number of nesting levels for this processing system is 50.

F2160: errmsg

The error indicated by `errmsg` has occurred. This message is displayed if the `#error` directive is used in the source program.

F2230: compiler limit: initialization nests too deep [*num*]

The nesting of the initializer list is too deep. The maximum depth value for this processing system is 100 levels.

F2410: compiler limit: too many case labels [*num*]

The number of case labels in the switch statement exceeds the limit. The maximum value for this processing system is 1025.

F2608: cannot recover from earlier errors

The processing cannot continue due to an error that occurred previously.

F2620: unknown cpu type, cannot compile

Compilation cannot be executed because a target device is not specified.

F2622: duplicated cpu type

A target device specifications is duplicated by an option or the `#pragma` directive.

F2623: cannot find device file

A device file corresponding to the specified target device was not found, or an incorrect target device has been specified.

F2624: device file read error

Reading of the device file has failed. The device file may have been corrupted.

F2625: illegal placement '`#pragma cpu`'

The position of the `#pragma` directive that specifies a device name is illegal. Place the device specification code before the syntax of the C language.

F2626: illegal cpu type: type

Correspondence of device specification is not established. Specify a device corresponding to the ca850 that is used.

F2628: device file version mismatch, cannot use version '*version*'

Format version of device file is invalid.

F5001: unknown option '*option*'

An illegal option *option* is specified.

F5005: invalid argument of option '*option*'

The argument of option *option* is illegal.

F5104: out of memory

Memory capacity is insufficient.

F5106: exception exception has occurred at compile time.

An exception exception related to floating-point operations occurred at compile time.

F5601: cannot allocate register to '*symbol*'

The value *symbol* cannot be allocated to the register.

F5901: cannot open file '*file*'

File *file* cannot be opened.

F5902: cannot write file '*file*' (errno = *num*)

Error having error number *num* occurred during write to file *file*.

F6000: cannot open file '*file*'

File *file* cannot be opened.

F6002: cannot unlink file '*file*'

File *file* cannot be deleted.

F6003: -wreg *num* is out of range(*num1* = <*num* = <*num2*)

The value of *num* specified for the -wreg option is outside of the specifiable range. Specify a value that is greater than *num1* and less than *num2*.

F6004: -rreg *num* is out of range(*num1* = <*num* = <*num2*).

The value of *num* specified for the -rreg option is outside of the specifiable range. Specify a value that is greater than *num1* and less than *num2*.

F6005: cannot write file '*file*' (errno = *num*)

Error having error number *num* occurred during write to file *file*.

F6203: out of memory

Memory capacity is insufficient.

F6500: unknown option '*option*'

An illegal option *option* is specified.

F6510: too many files

Too many file names are specified.

F6520: out of memory

The memory capacity is insufficient.

F6530: cannot open file '*file*'

File *file* cannot be opened.

F6540: cannot write file '*file*'

An error occurred while file *file* was being written.

F6550: cannot read file '*file*'

An error occurred while file *file* was being read.

F6560: cannot create file '*file*'

File *file* cannot be generated.

F6580: input line is too long

One line of the input file is too long.

F7000: too many errors

Compilation has stopped because errors exceeding the specified error count have occurred.

F7001: unknown option '*option*'

An illegal option *option* has been specified.

F7002: invalid argument of option '*option*'

The argument of the option *option* is illegal.

F7003: nested command file '*file*'

The command file *file* is nested. It must not be nested.

- F7004: no input file
No input file is specified.
- F7005: cannot open file '*file*'
File *file* cannot be opened.
- F7006: archive symbol table and archive member mismatch
An abnormality occurred in the archive symbol table.
- F7007: unknown file type '*file*'
The file type of *file* is not known.
- F7009: out of memory
Memory capacity is insufficient.
- F7010: multiple defined symbol '*symbol*'
Multiple-defined symbol *symbol* exists.
- F7011: duplicated cpu type
A target device is specified in duplicate by an option or the #pragma directive.
- F7012: cannot write file '*file*' (errno = *num*)
Error of error number *num* occurred during write to file *file*.
- W1111: sorry, not implemented option '*option*', ignored
Option *option* is not supported. It is ignored.
- W1112: -G option needs size(>=0): ignored
A size must be specified for the -G option. It is assumed that • has been specified.
- W1114: file '*file*' with unknown suffix passed to ld
File *file* is a file with an unknown suffix. It is passed to the ld850.
- W1116: sorry, '*suffix*' file not supported, ignored
File with suffix *suffix* is not supported. It is ignored.
- W1119: *option1* option overrides *option2* option.
Option *option2* becomes invalid because option *option1* is specified.
- W1120: *option1* option obsolete, use *option2* instead
Option *option1* is an option from an older version. Use option *option2* instead.
- W1123: '-Xcre_sec_data' option ignored, for '-Xcre_sec_data_only' option
-Xcre_sec_data option becomes invalid because -Xcre_sec_data_only option is specified.
- W1126: -cn option must be used with V850 core, used -cnv850e option instead
Option -cn must be used with a V850 core device. Instead, option -cnv850e is used.
- W1127: '*option*' option is not supported for V850 core.
Option *option* is not supported by a V850 core device.

- W1128: cannot find programmable peripheral I/O registers, ignored
A programmable peripheral I/O register cannot be found. The option is ignored.
- W1129: -cnv850e option must be used with V850E core, used -cnv850e2 option instead
Option -cn must be used with a V850 core device. Option -cnv850e2 is used instead.
- W1130: -cnv850e option must be used with V850E core, used -cnv850e2 option instead
Option -cnv850e must be used with a V850Ex core device. Option -cnv850e2 is used instead.
- W1308: output file of *option1* overrides output file of *option2*
The output file of option *option1* is overwritten because the output file of option *option2* is specified.
- W2015: illegal warning message number '*num*' specified by '*option*'
num specified by option is not a correct warning message number.
- W2042: illegal argument for `_rcopy`
The argument of copy routine `_rcopy` is illegal.
- W2107: Non empty file is expected to end in new-line character.
A file that is not empty must be terminated with a carriage return.
- W2127: redefined macro name '*name*'
Macro name *name* is redefined. The name defined afterward is valid.
- W2132: macro recursion '*name*'.Macro is expanded only one time.
Macro recursion was found. The macro is expanded only once.
- W2150: unexpected character(s) following directive '*directive*'
An unnecessary token was found after preprocessing directive *directive*. The unnecessary token is ignored.
- W2161: unexpected non-whitespace before preprocessing directive
A character other than a blank character exists before a processing directive.
- W2162: unrecognized pragma directive '`#pragma directive`', ignored
`#pragma directive` is not recognized. This pragma directive is ignored.
- W2163: Digit sequence after '`#line`' is interpreted as a decimal integer.
A numeric string following `#line` is interpreted as a decimal number.
- W2166: recognized pragma directive '`#pragma directive`'
The preprocessing directive is recognized as the `#pragma directive`.
- W2172: constant out of range
The constant value exceeds the specifiable range. It is assumed that only the lower valid number of digits has been specified.
- [Remark]
This message is output if the constant value exceeds the range that can be expressed for a type.
- [Example]
Assignment of a value 0xff or greater to a char variable

W2176: hexadecimal digit out of range

The specifiable range of a hexadecimal value was exceeded. The last two characters are valid for this processing system.

W2180: cannot convert *code1* code into *code2* code (*data data1 data2 data3*)

code1 cannot be converted into *code2*.

code1 : Character code of host environment

code2 : Character code of execution environment

*data** : Data that could not be converted (in hexadecimal)

W2212: Declaration of name hides parameter.

Because a symbol name identical to that of the argument is declared, the symbol is assumed to be valid, and declaration of the argument is hidden. This warning message is error message E2211 when the `-ansi` option is specified.

W2215: Undeclared function '*function*' is called.

Function *function* that is not declared is called. This warning message is output only when `-w2` is specified.

W2216: Nothing is declared.

No declarator was specified.

W2222: Plain int bitfield is treated as unsigned int.

The bit field of plain int is regarded as unsigned int.

W2231: Initialization of non-auto pointer using non-number initializer is not position independent.

The code for an initialization directive using an initial value other than that of a pointer variable that is not an automatic variable is not position-independent. This message is output only when `-w2` is specified.

[Remark]

This message is output when a code for an initialization command using the default value other than the value of a pointer variable that is not a dynamic variable exists. This warning message is supported for a position independent code (PIC).

[Example]

```
int *ip = &I;
```

If this is initialized and if *ip* is an automatic variable, a value is assigned during execution. Therefore, this is a PIC. If *ip* is not an automatic variable, a value is determined during compilation, and this code is not a PIC. Consequently, this warning message is output. If a program is allocated to the TEXT segment and a variable is allocated to the DATA segment with the CA850, the program branch and variable reference is a TP register- or GP register-relative code. Even if the code is copied to a different address from the address allocated during linking, during execution, the program correctly runs if the set values of the TP and GP registers are changed.

PIC is a code that is not dependent upon an allocated address. To assign an address to an external pointer variable as a default value, an address for linking is assigned. If an address is changed during execution, therefore, the program does not run correctly. This means that the code is not a PIC, and

therefore, this warning message is output.

If an r0-relative code (such as a CONST segment) is used, however, the code is not a PIC because the address is an absolute address (relative from address 0).

W2244: 'asm' used out of function is not supported completely.

Use of assembler description asm described outside the function, and the assembler description between #pragma asm and #pragma endasm is limited (refer to CA850 for C Language User's Manual).

W2267: illegal use of 'specifier'

Storage area class specifier "*specifier*" is not used correctly.

W2287: Function requires return value.

No return value is specified for a function having a return value. It is assumed that 0 is specified as the return value.

W2289: return type mismatch *type1* (*type2*)

Type *type2* of the return value indicated by the return statement does not agree with the return type *type1* of the function.

W2291: argument type mismatch *type1* (*type2*)

Type *type2* of an actual argument does not agree with *type1* of the dummy argument upon declaration of a function.

W2293: Type specifier of argument name is missing.

The type specifier of dummy argument name declared in the function definition is omitted. int type is assumed. This warning message is error message E2292 when the -ansi option is specified.

W2302: illegal bit-field type

A type that cannot be specified with the ANSI specifications is specified for a bit field. Padding is executed under the alignment condition of the specified type. This warning message is error message E2301 when the -ansi option is specified. This warning message is output only when -w2 is specified.

W2306: The bit-field object '*name*' is put into the next unit.

The bit field name is located in the next area because it exceeds the boundary. This warning message is output only when -w2 is specified.

W2373: used '&' for member of packed structure

An address is used for a member of the structure that has been packed.

[Remark]

If either of the conditions below apply to structural packing performed, data loss or truncation could arise in accessing structure member addresses since data access is performed by masking addresses according to the device's data alignment.

- Using a device that does not support misaligned access
- Using a device that supports misaligned access but prohibits it

[Example]

```

struct test {
    char c;      /* offset 0 */
    int i;      /* offset 1-4 */
} test;
int *ip, i;
void func(){
    i = *ip;
}
void func2(){
    ip = &(test.i);
}

```

W2380: function returns address of local variable

The address of an automatic variable is specified as the return value of a function. Do not return the address of an automatic variable.

Do not use the address of an automatic variable as a return value as follows.

[Example]

```

void* func(void)
{
    int i;
    return &i;
}

```

W2416: over 0x2000 tables, ignored -Xcase=table option

Because the number of tables exceeds 0x2000, they are output in the if-else format. -Xcase=table is ignored.

W2520: Immediate for shift operator is out of range.

The immediate value specified for the shift directive exceeds the value of the range that can be specified. It is assumed that only the lower valid digits have been specified.

W2521: division by zero

Division by zero is executed during the operation of a constant expression that is executed upon compiling. It is assumed that 0 is specified for the constant expression.

W2525: illegal type combination for 'operator' (type1, type2)

The combination of *types* (*type1*, *type2*) for operator *operator* is not correct. Type-conversion is executed and processing continues. This warning message is error message E2524 when the -ansi option is specified.

W2527: Operands of 'operator' operator must have same type (type1, type2).

The types to the left and the right of operator *operator* must be the same (*type1*, *type2*).

W2554: cannot convert non-lvalue array to pointer

An array that is not at the left side cannot be converted into a pointer. This warning message is error message E2553 when the -ansi option is specified.

W2555: *expression* *expression* must have enumeration type.

expression must be of enum type.

W2600: ignored option '*option*'

Option *option* is ignored.

W2601: *category* is not supported now.

The feature indicated by *category* is not supported at present.

W2606: Wide-character is not supported.

Wide characters are not supported and are ignored.

W2607: Multibyte-character is not supported.

Multi-byte characters are not supported and are ignored.

W2609: Specified warning message number '*num*' is not supported. Warning message number W2000-W2999 is supported now.

The specified warning message number *num* is not supported. The supported warning message numbers are 2000 to 2999.

W2621: duplicated *cpu* type, command line option is used

A target device is specified in duplicate. The target device specified at project file setup or by the `-cpu` option is valid.

W2634: Interrupt attribute is specified for function '*function*', previously specified '`block_interrupt`' is ignored.

Function *function* that is interrupt-inhibited is specified as an interrupt handler. Because the interrupt handler is interrupt-inhibited, unnecessary interrupt inhibit specification is ignored.

W2635: Interrupt attribute is already specified for function '*function*', '`block_interrupt`' is ignored.

Function *function* has been already declared as an interrupt handler. Because the interrupt handler is interrupt-inhibited, unnecessary interrupt inhibit specification is ignored.

W2637: Interrupt function cannot be inlined, '`inline`' is ignored.

"inline" must not be specified for a function declared as an interrupt. The inline specification is ignored.

W2643: Interrupt attribute is specified for function '*function*', previously specified '`inline`' is ignored.

Function *function* for which inline was specified is specified as an interrupt handler. The inline specification is ignored.

W2656: unknown size, cannot specified `const/sconst` section

A `const/sconst` section must not be specified for a variable with unknown size.

W2671: Function '*function*' is already defined, directive '`#pragma inline`' is ignored.

The inline specification must be described before the function definition. The inline specification is ignored.

- W2683: Second argument *'name'* for `__set_il` is not interrupt request name.
name specified as the second argument of a function that sets an interrupt level is not an interrupt request name. The interrupt level is not set.
- W2684: cannot set interrupt level for *'name'*
An interrupt level cannot be set for interrupt request name *name*. The interrupt level is not set.
- W2690: *'Rtos_task'* is specified for function *'function'*, previously specified *'inline'* is ignored.
A function for which inline is specified is specified as a task for the RTOS. The inline specification is ignored.
- W2691: Startup routine for RTOS task cannot be inlined, *'inline'* is ignored.
Inline expansion must not be specified for a function specified as a task for the RTOS. The inline specification is ignored.
- W2699: Function *'function'* is undefined, previously specified GP symbol for `rtos_interrupt` is ignored.
The function specified as an interrupt handler with a gp symbol specified is not defined in the file.
The interrupt handler specification is invalid.
- W2700: cannot specify GP symbol, function *'function'* is already defined
The gp symbol cannot be specified for a function already defined. The gp symbol specification is ignored.
- W2703: GP symbol is not specified for RTOS interrupt function *'function'*
A gp symbol is not specified for a function *function* specified as an RTOS interrupt handler.
- W2704: Function *'function'* is undefined, previously specified *'rtos_task'* is ignored.
Function *function* specified as an RTOS task is not defined in the file. The `rtos_task` specification is invalid.
- W2710: Section *'section1'* is already specified for *'symbol'*. *'section2'* is ignored.
section1 has been already specified in a section file for symbol *symbol*. *section2* that has been specified later is ignored.
- W2711: Different section is specified for *'symbol'* in source file(*section1*) and section file(*section2*). Source file specification is ignored.
Section specification (*section1*) for the source file and section specification (*section2*) for the section file for symbol *symbol* differ. The section specification (*section1*) for the source file is ignored.
- W2730: Block interrupt function cannot be installed, *'inline'* is ignored.
"inline" must not be specified for a function declared to disable interrupts. inline specification is ignored.
- W2731: Block interrupt attribute is specified for function *'function'*, previously specified *'inline'* is ignored.
Function *function* specified as "inline" is specified to disable interrupts. inline specification is ignored.
- W2740: `#pragma text function-name` must be placed before the function's

definition. '#pragma text *function*' is ignored.

The text section must be specified before the function definition. The text section specification for a function *function* is ignored.

W2741: Function specified as 'direct' can not be allocated in text. '#pragma text *function*' is ignored.

The text section cannot be specified for a function specified as interrupt in direct location (direct). The text section specification for a function *function* is ignored.

W2742: Function allocated in text can not be specified as 'direct'. Previously specified '#pragma text *function*' is ignored.

Function specified as text section cannot be specified as interrupt in direct location (direct). The text section specification for a function *function* already specified is invalid.

W2743: Function allocated in text can not be inlined. '#pragma inline *function*' is ignored.

"inline" cannot be specified for a function specified as text section. The inline specification for a function *function* is ignored.

W2744: Function allocated in text can not be inlined. Previously specified '#pragma inline *function*' is ignored.

text section is specified to a function specified as inline. The inline specification for a function *function* already specified is invalid.

W2748: Section name is not specified.

The section name is not specified between single quotes (") when specifying the section name of a #pragma section. It is assumed that no section name is specified, and allocated to the reserved section of the specified attribute.

W2761: unrecognized specifier '*specifier*', ignored

Specifier *specifier* cannot be recognized. This specifier is ignored.

W2780: result of comparison is always false

The result of the comparison expression is false.

W2782: statement with no effect

There is a statement without meaning.

W2784: Conversion may lose significant digit

The data may have been lost.

W5009: sorry, not implemented option '*option*', ignored

Option *option* is not supported at present and is ignored.

W5501: The section of variable '*symbol*' was changed from '*old*' to '*new*'.

The section of variable *symbol* has been changed from '*old*' to '*new*'.

W5502: The size of variable '*symbol*' was changed from *old* to *new*.

The size of variable *symbol* has been changed from '*old*' to '*new*'.

W5503: The alignment of variable '*symbol*' was changed from *old* to *new*.

The alignment of variable *symbol* has been changed from 'old' to 'new'.

W5504: The initial value of variable '*symbol*' was changed.

The default value of variable *symbol* has been changed.

W6101: immediate for shift operator is out of range

The value of the immediate value specified for the shift directive exceeds the specifiable range. It is assumed that only the lower valid digits have been specified, and processing continues.

W6102: first argument of `_rcopy()` is illegal

The first argument of copy routine `_rcopy()` is illegal.

W7101: sorry, not implemented option '*option*', ignored

Option *option* is not supported at present and is ignored.

W7102: redeclaration of '*symbol*'

symbol is redeclared.

W7103: Symbol '*symbol*' has different size (*num1* and *num2*).

Different sizes (*num1* and *num2*) of data symbol *symbol* have been merged.

W7104: Symbol '*symbol*' has different alignment size (*num1* and *num2*). Changed to least common multiple value (*num3*).

Different alignment size (*num1* and *num2*) of data symbol *symbol* have been merged. The size is changed to the maximum common multiple *num3*.

W7105: cannot hide symbol '*symbol*'

Symbol *symbol* cannot be hidden.

W7106: Argument type mismatch is detected where '*caller*' calls '*callee*'.

The types of the arguments of *caller* and *callee* differ during inline expansion. If the types can be changed, they are converted into the types for definition. If not, the inline expansion is ignored.

W7107: Return value type mismatch is detected where '*caller*' calls '*callee*'.

The types of the return values of *caller* and *callee* differ during inline expansion. If the type of *callee* can be changed, it is converted into the type of *caller*. If not, the inline expansion is ignored.

B.1.3 Assembler

E3200: illegal alignment value

The specified alignment condition is incorrect.

E3201: illegal character

A character that cannot be handled has been found.

E3202: illegal expression

The syntax of the expression is incorrect.

E3203: illegal expression (*string*)

Element *string* of the expression is incorrect.

E3204: illegal expression (-label)

An expression in the format (-label) is used.

E3205: illegal expression (-label -label)

An expression in the format (-label -label) is used.

E3206: illegal expression (label + label)

An expression in the format (label + label) is used.

E3207: illegal expression (labels have different reference types)

An operation is specified between label references in different formats (#label, label, and \$label).

E3208: illegal expression (labels in different sections)

An operation is specified between labels belonging to different sections.

E3209: illegal expression (labels must be defined)

Define an option between labels in the same file.

E3210: illegal expression (not + nor -)

An operator other than + or - is used.

E3211: floating exception (*function*)

The floating-point operation of function *function* of the floating-point operation library internally used by the as850 is incorrect.

E3212: symbol already defined as label

The specified symbol has already been defined as a label.

E3213: label *identifier* redefined

Label *identifier* has been defined more than once.

E3214: *identifier* redefined

identifier has been defined more than once.

E3215: illegal operand (access width mismatch)

On-chip peripheral I/O registers with different access widths are specified as operands.

- E3216: illegal operand (cannot read I/O register which does not have read access)
Reading the on-chip peripheral I/O register specified as the operand is prohibited.
- E3217: illegal operand (cannot use bit I/O register)
A bit of the flag of an on-chip peripheral I/O register must not be specified as an operand.
- E3218: illegal operand (cannot write I/O register which does not have write access)
Writing the on-chip peripheral I/O register specified as the operand is prohibited.
- E3219: illegal operand (inconsistent bit position)
The bit position specified by the bit manipulation instruction is contradictory.
- E3220: illegal operand (*identifier* is reserved word)
Reserved word *identifier* is used in a name.
- E3221: illegal operand (label - label)
An expression in the format of (label - label) is specified for a branch instruction.
- E3222: illegal operand (label not allowed)
A label is specified for an instruction for which a label must not be specified as an operand.
- E3223: illegal operand (label not allowed for setf/shl...)
A label is specified for the setf or shift instruction.
- E3224: illegal operand (label reference for jmp must be #label)
An absolute address reference (#label) is not specified for the jmp instruction.
- E3225: illegal operand (must be evaluated positive or zero)
The result of evaluating the expression is negative.
- E3226: illegal operand (must be even displacement)
An odd displacement is specified.
- E3227: illegal operand (must be immediate, label or symbol for hi/lo/hi1)
Immediate, label, or symbol is not specified for hi, lo, and hi1.
- E3228: illegal operand (must be register)
A register is not specified.
- E3229: illegal operand (needs base register)
A base register must be specified.
- E3230: illegal operand (range error in displacement)
The value specified as displacement exceeds the range of specifiable values.
- E3231: illegal operand (range error in immediate)
The value specified as immediate exceeds the range of specifiable values.
- E3232: illegal operand (.local parameter)
The parameter specified for the .local quasi directive is illegal.

E3233: illegal operand (local symbol parameter)

The parameter specified for the `.local` quasi directive is not a symbol.

E3234: illegal operand (macro parameter)

The parameter specified for the `.macro` quasi directive is illegal.

E3235: illegal operand (macro name)

The macro name specified for the `.macro` quasi directive is illegal.

E3236: illegal operand (macro argument)

The parameter specified for the macro call is illegal.

E3237: illegal operand (`.irepeat` argument)

The argument specified for the `.irepeat` quasi directive is illegal.

E3228: illegal operand (`.irepeat` parameter)

The parameter specified for the `.irepeat` quasi directive is illegal.

E3239: illegal operand (can not use `r0` as source in V850E mode)

`r0` must not be specified as the source operand when the V850Ex core is specified.

E3240: illegal operand (can not use `r0` as destination in V850E mode)

`r0` must not be specified as the destination operand when the V850Ex core is specified.

E3241: illegal operand (too many registers)

Too many registers are specified for the `pushm/popm` instruction.

E3242: illegal operand (label is already defined on *section*)

The label specified for `.option sdata/.option data` has already been defined in section *section*.

E3244: illegal origin value(*value*)

The value(*value*) specified for the `.org` quasi directive is incorrect.

E3245: *identifier* is reserved word

Reserved word *identifier* is used where a reserved word should not be used.

E3246: illegal section

An instruction that must not be described in a section is described.

E3247: illegal size value

The specified size is incorrect.

E3248: illegal symbol reference (`$symbol`)

"\$" or "#" is specified for a symbol.

E3249: illegal syntax

The syntax is incorrect.

E3250: illegal syntax string

The syntax of string is incorrect.

E3251: illegal id value

The specified ID value is incorrect. Specify an integer.

E3252: id already defined as symbol "*identifier*"

The specified ID value has already been reserved as symbol name "*identifier*".

E3253: symbol "*identifier*" already defined as another id

The specified symbol name "*identifier*" has already been reserved as a different ID value.

E3254: can not reference .ext_func symbol "*identifier*"

The symbol specified by using the .ext_func quasi directive cannot be referenced by any instruction other than a branch instruction.

E3255: cannot access for I/O register bit number "*I/O register*"

The bit number specified for I/O register name "*I/O register*" is incorrect.

E3258: cannot access I/O register ("*I/O register*")

Accessing the on-chip peripheral I/O register "*I/O register*" specified as an operand is prohibited.

E3259: can not use r1 as destination in mul/mulu.

An assembler-reserved register (r1) must not be specified as the destination register of the mul/mulu instruction.

E3260: token too long

The length of the token exceeds the limit. The limit value is 1037.

E3261: illegal condition code.

The specified condition code is illegal.

Oxd cannot be specified to the condition codes for adf and sbf commands [V850E2].

F3500: too many files

More than one file must not be specified.

F3501: illegal bit width

The bit width specified for the .byte, .hword, or .word quasi directive is illegal.

F3502: illegal file name (must be .s file)

The extension of the input file is illegal. Use extension .s.

F3503: can not open file *file*

File *file* cannot be opened.

F3504: illegal section kind

The type of the section specified for the .section quasi directive is incorrect.

F3505: memory allocation fault

The memory capacity is insufficient.

F3506: memory allocation fault (*string*)

Allocating an internal data area (*string*) has failed.

F3507: overflow error (*string*)

The work area is insufficient for processing the expression.
Simplify the expression.

F3508: *identifier* undefined

An undefined identifier *identifier* is referenced.

F3509: illegal pseudo (*string*) found

An unexpected quasi directive string has been found.

F3510: *string* unexpected

No quasi directive corresponding to the string quasi directive has been found.

F3511: *string* unmatched

Quasi directive *string* corresponding to a conditional assembly quasi directive does not exist.

F3512: .if, .ifn, etc. too deeply nested

Conditional assembly quasi directives are nested 17 times or more.

F3513: unexpected EOF in *string*

The .endm quasi directive corresponding to the *string* quasi directive was not found.

F3514: parameter table overflow

Thirty-three or more actual parameters are used.

F3515: *string* not in .repeat/.irepeat

The *string* quasi directive is not enclosed by repeat assemble quasi directives.

F3516: local symbol value overflow

The number of symbols generated by the .local quasi directive has exceeded the limit (65536).

F3517: *string* nest over

string is nested more than nine times.

F3518: unreasonable macro_call nesting

A macro currently being defined is called in a macro body.

F3519: argument mismatch

The argument specified for the macro call is illegal.

F3520: \$ must be followed by defined symbol

An identifier name or undefined symbol name other than a symbol is specified after "\$".

F3521: too many errors

The number of fatal errors has reached 30. Assembly is stopped.

F3522: unknown cpu type

Assembly cannot be executed because no target device is specified.

F3523: duplicated cpu type

Target devices are specified in duplicate by an option or quasi directive.

F3524: can not find devicefile

A device file corresponding to the specified target device is missing, the specified device is incorrect, or no device is specified.

F3525: illegal cpu family

The specified device file is not for the V850 microcontrollers.

F3526: devicefile version mismatch, cannot use version *version*

The version of the specified device file is illegal.

Version *version* must not be specified.

F3527:nested command file *file*

Command file *file* is nested. It must not be nested.

F3528: .tidata.byte/.tibss.byte size overflow(size > 128).

The total size of the .tidata.byte section and .tibss.byte section exceeds 128 bytes.

F3529: .tidata.word/.tibss.word size overflow(size > 256).

The total size of the .tidata.word section and .tibss.word section exceeds 256 bytes.

F3530: .tidata/.tibss size overflow (size > 256).

The total size of the .tidata.byte section, .tibss.byte section, .tidata.word section, .tibss.word section, .tidata section, and .tibss section exceeds 256 bytes.

F3531: too many symbols

The number of symbols that can be described in one file has been exceeded.

The maximum number of symbols that can be described is 16,777,215, including those registered internally by the assembler.

F3532: illegal object file (*string*)

An error dependent upon the file system has occurred in the course of generating a linkable object file.

W3000: .option *az_info_kind* unmatched, ignored.

.option *az_info_kind* is specified at an illegal position. It is ignored.

W3001: too many actual parameter .

Too many actual parameters are specified for the macro call.

W3002: can not use *option1* with *option2*, *option2* ignored.

Options *option1* and *option2* must not be specified at the same time. Option *option2* is ignored.

W3003: "*option*" option needs argument, ignored.

An argument must be specified for option *option*. The specified option is ignored.

W3004: illegal "*option*" option's value, ignored.

The value specified for option *option* is illegal. The specified option is ignored.

W3005: illegal "*option*" option's symbol "*symbol*", ignored.

Symbol *symbol* specified for option *option* is illegal. The specified option is ignored.

W3006: illegal "*option*" *option*'s argument, ignored.

The argument specified for option *option* is illegal. The specified option is ignored.

W3007: *option*, -cpu mismatch, ignore -cpu, output *core* common object.

Option *option* that specifies generation of an object common to core *core* and the device file specified by the -cpu option do not match. The -cpu option is ignored, and an object common to core *core* is generated.

W3008: *option* option is not supported for *core* *core*.

Option *option* is not supported by core *core*. The specified option is ignored.

W3009: can not find programmable peripheral I/O registers, ignored -bpc option.

Information of the programmable peripheral I/O register does not exist. The -bpc option is ignored.

W3010: illegal displacement in *inst* instruction.

The value of displacement exceeds the specifiable range. It is assumed that only the valid lower digits have been specified and assembly is continued.

W3011: illegal operand (range error in immediate).

The value of immediate exceeds the specifiable range. It is assumed that only the valid lower digits have been specified and assembly is continued.

W3012: hword overflow.

The value specified for .hword/.shword exceeds the specifiable range. It is assumed that only the valid lower digits have been specified and assembly is continued.

W3013: *register* used as *kind* register.

A mask register (r20 or r21) is specified for operand as the *kind* register when the register (r0), assembler-reserved register (r1), or mask register function is used.

W3014: illegal list value, ignored.

The value specified for the register list of the prepare/dispose instruction is illegal. It is assumed that only the valid lower digits have been specified and assembly is continued.

W3015: illegal register number, ignored.

The register specified for the register list of the prepare/dispose instruction is illegal. It is assumed that only the valid lower digits have been specified and assembly is continued.

W3016: illegal operand (access width mismatch).

An on-chip peripheral I/O register with a different access width is specified as an operand.

W3017: base register is ep(r30) only.

ep is not specified for the base register of the sld/sst instruction.

W3018: illegal regID for *inst*.

Accessing the system register of the number specified for the *inst* instruction is prohibited.

W3019: illegal operand (immediate must be multiple of 4).

The value specified as the operand must be a multiple of 4. Fractions are rounded down and assembly is continued.

W3020: duplicated *cpu type*, ignored *.option cpu*.

The target device specified by the *-cpu* option is different from that specified by the *.option quasi* directive. The *-cpu* option takes precedence, and the target device specified by the *.option quasi* directive is ignored.

W3021: *string* already specified, ignored.

A number different from the number of registers previously specified is specified for *string*. The number already specified is used and this specification is ignored.

W3022: duplicated *option*, ignored.

option is specified more than once. The option already specified is used. This specification is ignored.

W3023: BPC value is out of range (*0x0-value*), ignored *-bpc option*.

The value specified for *-bpc* is outside the permissible range (*0x0-value*) of the device. The specified value is ignored, and the default value of the device is used.

W3024: sorry, *option option* not implemented, ignored.

Option *option* is not implemented. It is ignored.

W3025: sorry, *option option* not implemented, ignored.

Option *option* is not implemented. It is ignored.

W3026: illegal register number, aligned odd register(*rXX*) to be even register(*rYY*).

A register with an odd number (*r1, r3, ... r31*) was specified.

Only general-purpose registers with even numbers (*r0, r2, r4, ... r30*) can be specified.

Assembly will continue as if a register with an even number (*r0, r2, r4, ... r30*) has been specified.

B.1.4 Linker

E4231: ';' is expected at the end of directive.

"," is required at the end of the directive.

E4232: '}' is expected.

"}" is required.

E4233: name is expected at the beginning of directive.

Start a directive with a name (segment, section, or symbol name).

E4234: section name is expected at the beginning of section directive.

Start a section directive with a section name.

E4235: ':', '=' or '@' is expected to follow name.

The name that begins a directive must be followed by ":", "=", or "@".

E4236: '=' is expected to follow section name.

"=" is required at the end of an output section name.

E4237: too many '}'.

Too many "}" are specified for "{".

E4238: illegal character (*number*).

An illegal character (*number*) exists in the link directive.

E4239: *string* needs effective parameter.

A valid parameter is necessary for *string*.

E4240: *string* is illegal in segment directive.

string must not be specified in the segment directive.

E4241: *string* is illegal in section directive.

string must not be specified in the section directive.

E4242: *string* is illegal in symbol directive.

string must not be specified in the symbol directive.

E4243: *string* is illegal in file specification field.

string must not be specified in the portion that specifies a file name.

E4244: *string* illegal in segment name field.

string must not be specified in the portion that specifies a segment name.

E4245: *string* specified to segment "*segment*" more than once in same or other directive.

string has been specified more than once in the same segment directive or another segment directive for segment *segment*.

E4246: *string* specified to section "*section*" more than once in same or other directive.

string has been specified more than once in the same section directive or another section directive for section *section*.

E4247: *string* specified to symbol "*symbol*" more than once in same or other directive.

string has been specified more than once in the same symbol directive or another symbol directive for symbol *symbol*.

E4248: segment "*segment*" already defined.

Segment *segment* has been already defined.

E4249: section "*section*" already defined at line(*number*).

Section *section* has been already defined on the *numberth* line.

E4250: symbol "*symbol*" already defined at line(*number*).

Symbol *symbol* has been already defined on the *numberth* line.

E4251: illegal segment type "*string*".

string was specified; it must not be specified as a segment type.

E4252: illegal section type "*string*".

string was specified; it must not be specified as a section type.

E4253: illegal section attribute '*character*'

character was specified; it must not be specified as a section attribute.

E4254: *string* in segment directive of non LOAD segment is illegal.

string must not be specified in a segment directive that does not specify LOAD as the segment type.

E4267: unknown symbol kind "*string*".

string has been specified; it must not be specified as a symbol type.

E4268: symbol kind "*string*" specified more than once in same or other directive.

Symbol type *string* has been defined more than once in the same or another directive.

E4271: section attribute '*attribute*' of section "*section*" and segment attribute '*attribute*' of segment "*segment*" do not match.

The section attribute *attribute* of section *section* does not match the segment attribute of segment *segment* to which this section is specified to be allocated.

F4001: cannot open command file "*file*".

The command file *file* cannot be opened.

F4002: cannot open input file "*file*".

Input file *file* cannot be opened.

F4003: cannot open output file "*file*".

Output file *file* cannot be opened.

F4004: cannot create output file "*file*".

Output file *file* cannot be created.

F4005: cannot open directive file "*file*".

The directive file *file* cannot be opened.

F4006: cannot get size of directive file "*file*".

Retrieval of the size of directive file *file* has failed.

F4007: cannot read directive file "*file*".

Directive file *file* cannot be read.

F4008: cannot truncate output file "*file*" to have size(*number*).

The size of the output file *file* cannot be changed to *number* bytes.

F4009: cannot seek output file "*file*".

Output file *file* cannot be sought.

F4010: cannot write output file "*file*".

The output file *file* cannot be written.

F4011: cannot find device file "*string*".

The device file *string* cannot be found.

F4012: illegal device file "*string*".

The device file *string* is illegal.

F4013: cannot open device file "*string*",

The device file *string* cannot be opened.

F4014: cannot read device file "*string*".

The device file *string* cannot be read.

F4015: illegal object file (Error Number:*number*).

The object file is illegal.

F4031: illegal ELF version.

The ELF version of the specified object file is not a version that can be handled by the ld850.

F4032: illegal target machine type.

The type of the input file cannot be handled by the ld850.

F4033: illegal target machine class.

The class of the input file cannot be handled by the ld850.

F4034: illegal target machine byte order.

The byte order of the input file is not a byte order that can be handled by the ld850.

F4035: illegal ELF file type, must be relocatable or shared library file.

The relocatable object file and shared library file are the only types of object file that can be treated as an input file.

F4036: unknown format type file "*file*".

The specified file *file* has an illegal file format.

F4037: illegal devicefile. different family "*number*".

The device file is incorrect. Microcontrollers *number* is incorrect.

F4038: "*file*" is not executable file.

The boot file *file* specified by the `-zf` option is not in an executable format. Specify an executable file output by the ld850.

F4039: "*file*" is rom packed file.

The boot file *file* specified by the `-zf` option is ROMized. Specify an executable file output by the ld850 that is not ROMized.

F4051: fail to get symbol name string.

Retrieval of a symbol name character string has failed.

F4052: failed to get *number* th symbol name string.

Retrieval of the *number*th symbol name character string has failed.

F4053: symbol "*symbol*" has unknown binding class(*number*).

The symbol *symbol* has an illegal binding class *number*.

F4054: weak symbol "*symbol*" not supported.

A symbol *symbol* having binding class WEAK is not supported.

F4058: symbol "*symbol*" multiply defined.

The symbol *symbol* is defined more than once.

[Caution]

If PM+ is used or if the startup file is registered as the source file of the project, the following message is displayed.

```
symbol "__start" multiply defined.
```

When PM+ is used, it is assumed that the default startup module is specified if nothing is specified as [Startup File](#) on the [\[Compiler Common Options\] dialog box](#).

Take either of the following actions.

- (1) Delete the startup file from the source file registration, and specify a startup file as [Startup File](#) on the [\[Compiler Common Options\] dialog box](#).
- (2) Create a dummy assembler file, assemble it and create ".o file", and specify it as [Startup File](#) on the [\[Compiler Common Options\] dialog box](#).

F4059: linking of symbol "*symbol*" in sdata of sbss attribute section in "*file1*" and in other attribute section in "*file2*" is attempted.

Symbol *symbol* defined in *file1* contradicts the section location of the symbol of the same name defined in *file2*.

F4060: cannot find entry point symbol "*symbol*" specified with "-e" option.

The symbol *symbol* specified by the entry point address specification option (-e) cannot be found.

F4063: ".ext_func ID, *symbol*" is already defined as ".ext_func ID, *symbol*" in other file.

The *symbol* name and ID value specified by the .ext_func quasi directive are inconsistent.

F4065: too many symbols.

The limit on the number of symbols has been exceeded. The upper limit on the number of symbols for relocatable object files created via the -r or -ro option is 16,777,125 symbols.

F4101: failed to get section name string table section.

Retrieval of the string table section of the section name has failed.

F4102: failed to get symbol name string table section.

Retrieval of a string table section has failed.

F4103: failed to get section header.

Retrieval of a section header has failed.

F4104: failed to get section name string.

Retrieval of a section name has failed.

F4106: section "*section*" has unknown section type(*number*).

The section *section* has an illegal section type *number*.

F4107: cannot get raw data of section "*section*".

Raw data retrieval of section *section* has failed.

F4109: interrupt function section "*section*" is already defined.

Interrupt handler section *section* has already been defined. Description of this section to the link directive is unnecessary because the ld850 automatically generates an interrupt handler section from the specified device file.

F4110: special section "*section*" is already defined.

Special section *section* is already defined.

F4112: illegal "*section*" section size.

The size of section *section* is illegal.

F4155: cannot find GP-symbol in segment "*segment*" of illegal label reference for local symbol in file "*file2*" (section:*section2*, offset:*offset*, type:relocation type). local symbol is allocated in section "*section1*" (file:*file1*).

The GP symbol cannot be found in the segment *segment*. Or, there is a contradiction in the location/reference method of the local symbol.

[Supplement]

If a section to be allocated by a #pragma section specification is changed by a variable definition, change a section for the extern declaration of the variable in another file in the same way. The local symbol is

allocated to *section1* of file *file1*. The reference to the local symbol exists at offset *offset* of section *section2* of file *file2*.

F4156: cannot find GP-symbol in segment "*segment*" of illegal label reference for "*symbol*" in file "*file2*" (section:*section2*, offset:*offset*, type:*relocation type*). "*symbol*" is allocated in section "*section1*"(file:*file1*).

The GP symbol was not specified in the segment *segment*. Or, there is a contradiction in the location/reference method of the symbol *symbol*.

[Supplement]

If a section to be allocated by a *#pragma* section specification is changed by a variable definition, change a section for the extern declaration of the variable in another file in the same way. The symbol *symbol* is located at *section1* of file *file1*. The reference to the symbol *symbol* exists at offset *offset* of section *section2* of file *file2*.

F4157: cannot find GP-symbol in section "*section*" of file "*file1*" or illegal label reference for symbol "*symbol*" in file "*file2*" (section:*section2*, offset:*offset*, type:*relocation type*). "*symbol*" is allocated in section "*section1*"(file:*file1*).

GP symbol is not defined in section *section* of executable file *file1* at the boot side. Or, there is a contradiction in the location/reference method of the symbol *symbol*.

[Supplement]

If a section to be located by *#pragma* section specification is changed by variable definition, change a section for the extern declaration of the variable in another file in the same way. Symbol *symbol* is located at *section1* of file *file1*. Reference to symbol *symbol* exists at offset *offset* of section *section2* of file *file2*.

F4158: relocated value(*value*) of relocation entry(symbol: *symbol*, file: *file*, section: *section*, offset: *offset*, type: *relocation type*) for branch command become odd value.

The value *value*, relocated by a branch relocation entry (symbol *symbol*, file *file*, section *section*, offset *offset*, relocation type *relocation type*) is an odd number.

F4160: EP symbol is needed for using SIDATA/SEDATA segment.

The ep symbol was not created. Create the ep symbol to use the SIDATA or SEDATA segment.

F4161: symbol "*symbol*" (output section *sectin1*) is too far from output section "*section2*".(value: *value*, file: *file*, input section: *section3*, offset: *offset*, type: *relocation type*).

The branch instruction from output section *section2* to the symbol *symbol* allocated to output section *section1* exceeds the branch destination range. The branch instruction exists at offset position *offset* for section *section3* in file *file*.

F4162: output section "*section1*" is too far from output section "*section2*". (value: value, file: *file*, input section: *section3*, offset: *offset*, type: *relocation type*).

The branch instruction from output section *section2* to the local symbol allocated to output section *section1* exceeds the branch destination range. The branch instruction exists at offset position *offset* for section *section3* in file *file*.

F4163: output section "*section1*" overflowed or illegal label reference for symbol "*symbol*" in file "*file2*" (value: value, file: *file*, input section: *section2*, offset: *offset*, type: *relocation type*). "*symbol*" is allocated in section "*section1*" (file: *file1*).

Output section *section1* overflowed. In addition, the section where symbol *symbol* was allocated and the label referencing method are illegal. *symbol* is allocated to *section1* by file *file1*. The illegal reference exists at offset *offset* for section *section2* of file *file2*.

F4164: output section "*section1*" overflowed or illegal label reference for local symbol in file "*file2*" (value: value, file: *file*, input section: *section2*, offset: *offset*, type: *relocation type*). local symbol is allocated in section "*section1*" (file: *file1*).

Output section *section1* overflowed. In addition, the section where a local symbol was allocated and the label referencing method are illegal. The local symbol is allocated to *section1* by file *file1*. The illegal reference exists at offset *offset* for section *section2* of file *file2*.

F4165: cannot reference extern symbol "*symbol*" by *string*.

The flash area's symbol *symbol* cannot be referenced by *string* when creating files on the boot area side using the flash/external ROM relink function.

F4166: no symbol information in boot file "*file*".

Base symbol information is not included in boot file *file* specified by the *-zf* option. Check if *-ext_table* is specified when the boot file is linked.

F4203: cannot find archive member at offset(*offset*) specified in archive symbol table entry.

An archive member is not found at the position of the offset *offset* specified by the archive symbol table entry. The contents of the archive symbol table may have been destroyed.

F4204: library path length is too long. path maximum size is 576.

The library path is too long. The path specification must be 576 characters or less.

F4257: segment "*segment*" overflowed highest address of target machine.

The area to which segment *segment* is specified to be allocated exceeds the target machine's internal memory range.

[Supplement]

This message is changed to a warning message by specifying *-Ximem_overflow=warning* option. This message can be erased by specifying the *-rom_less* option only if the cause of the error is related to the internal ROM.

F4258: segment directive of segment *"segment"* needs *string*.

A *string* is required for the segment directive of segment *segment*.

F4259: section directive of section *"section"* needs *string*.

A *string* is required for the section directive.

F4260: symbol directive of symbol *"symbol"* needs *string*.

A *string* is required for the symbol directive of symbol *symbol*.

F4263: start address(*number1*) of segment *"segment1"* overlaps previous segment *"segment2"* ended before address(*number2*).

The start address *number1* of segment *segment1* overlaps the area of segment *segment2* allocated up to address *number2*.

[Caution]

If a segment that must not overlap overlaps during linking and thus an error occurs, check that the segment of the higher address is described first in the specification of the link directive. Here is an example of the error.

[Example]

```
DATA1: !LOAD ?RW V0x300000 {
    .data= $PROGBITS?AW;
    .sdata= $PROGBITS?AWG;
    .sbss = $NOBITS?AWG;
    .bss= $NOBITS?AW;
};
TEXT : !LOAD ?RX V0x100000 L0x100000 {
    .text = $PROGBITS ?AX .text;
};
```

Sequentially specify the addresses of the segment, starting from the lowest address. Therefore, describe a segment to be allocated to the lower address first.

F4264: start address(*number1*) of section *"section1"* overlaps previous section *"section2"* ended before address(*number2*).

The start address *number1* of section *section1* overlaps the area of section *section2* allocated up to address *number2*.

F4265: start address(*number1*) of section *"section1"* overflowed start address(*number2*) of segment *"segment"*.

The start address *number1* of section *section* is allocated before the start address *number2* of segment *segment* to which it belongs.

F4266: memory size(*number1*) of segment *"segment"* overflowed specified or default maximum memory size(*number2*).

Memory size *number1* of segment *segment* exceeds the explicitly specified maximum memory size or default maximum memory size.

F4276: TP symbol "*symbol*" specified as GP symbol "*symbol2*"'s base symbol is not found.

The tp symbol *symbol1* specified as the base symbol of gp symbol *symbol2* is not found.

F4279: end address of section "*section*" overflowed maximum memory address(*number*).

The end address of section *section* overflows the maximum memory size *number*.

F4280: end address of segment "*section*" overflowed maximum memory address(*number*).

The end address of segment *segment* overflows the maximum memory size *number*.

F4282: segment "*segment*" (*number1-number2*) overflowed highest or lowest address of internal memory (*number3-number4*).

The area to which segment *segment* is specified to be allocated (*number1-number2*) exceeds the target machine's internal memory range (*number3-number4*).

[Supplement]

This message is changed to a warning message by specifying `-Ximem_overflow=warning` option. This message can be erased by specifying `-rom_less` option only if the cause of the error is related to the internal ROM.

F4286: section "*section*" must be specified in link directive.

The section *section* must be specified in a directive file.

F4287: description of section "*section*" in mapping directive is illegal.

The description (code entry) of section *section* in the directive file is illegal.

F4333: cannot allocate memory (builtin new error).

Securing a memory area has failed.

F4351: unknown option "*string*".

An illegal option *string* is specified.

F4353: '-' is illegal.

Cannot specify only "-".

F4355: nesting of command file "*file*" in command file is not supported.

Command file *file* is specified in a command file. Nesting of command files is not supported.

F4356: "*string1*" option is illegal when "*string2*" option is specified.

string1 option must not be specified when *string2* option is specified.

F4359: "*string*" option needs hexadecimal argument.

string option needs a hexadecimal argument.

F4361: illegal character (*number*) in "*string*" field.

An illegal character *number* (ASCII code) is used to specify the option string.

F4363: unknown cpu type.

Specify a target device.

[Supplement]

This message is output if creation of an executable object file is attempted by linking only the file that specifies the `-cn/-cnv850e/-cnv850e2` option of the `as850` when an object file which can be linked is created.

F4364: duplicated cpu type.

A target device has been specified two or more times. Different target devices are specified in the object files to be linked.

F4369: "*string1*" is illegal when "*string2*" option is specified.

string1 cannot be specified when option *string2* has been specified.

F4370: "*string1*" option needs "*string2*" option.

The *string2* option is needed by the *string1* option.

F4374: "*string*" option's value overflowed.

The value specified for the string option has overflowed.

F4404: symbol table overflow.

The symbol table area is insufficient.

F4409: sorry, shared library not supported.

A shared library is not supported.

F4411: multiple inclusion of same file attempted, ignored.

The same file is specified more than once as an input file.

[Caution]

If the boot object file name specified by `-zf` is the same as the input file name of the linker when a flash supporting object of the linker is created, this error occurs. In this case, change either of the file names.

F4412: command line length is too long. path maximum size is 512.

Too many characters are specified on the command line. The maximum number of characters that can be specified is 512 bytes.

F4413: *file* has different `.ext_ent_size`.

`.ext_ent_size` different from the others is specified for input file *file*. Make specification of `.ext_ent_size` in input files the same.

F4414: `CallTBasePointer(CTBP)` is not set. CTBP must be set when compiler option "`-Ot`" (or "`-Xpro_epi_runtime=off`") is not specified.

The `CallTBasePointer(CTBP)` was not set. Set CTBP when the option setting of the prologue/epilogue runtime library is not used (`-Xpro_epi_runtime=off`) or when level 2 advanced optimization (execution speed priority) "`-Ot`" is not specified.

[Note on calling prologue/epilogue runtime library]

The prologue/epilogue runtime library is included in the standard library. This error also occurs if link specification (`-lc`) of the standard library is not made. Check the link specification of the library.

F4415: S-JIS code (*number1*, *number2*) is broken in string.

S-JIS code specified for string is illegal.

F4451: multiple defined symbol.

```
symbol      defined file previous defiend file
symbol      file1          file2
```

Symbol *symbol* specified in *file1* has been already defined in *file2*.

F4452: undefined symbol.

```
symbol      referenced in "file"
```

The symbol *symbol* referenced in file *file* is not defined.

[Caution]

- (1) If this error occurs in the runtime library even when the link specification of the runtime library is made, check the sequence of the link specification of the library. The option `-l` must be specified after the archiver file to be specified only for external reference that has not been resolved when this option is specified. When this option `-rescan` is specified, symbols left unresolved because of the link sequence of the library can be prevented.

[Example]

[Example]

```
-lm -lc a.o b.o c.o
|
a.o b.o c.o -lm -lc
```

- (2) If the following error message is output while the library for storage management (`calloc`, `malloc`, `free`, `realloc`) is being used, secure the heap memory.

```
F4452: undfined symbol.
__sysheap(refrenced in "heapcom.o(c:\nectool32\lib850\r22\libc.a)")
__sizeof__sysheap(refrenced in "heapcom.o(c:\nectool32\lib850\r22\libc.a)")
```

- (3) If the peripheral function register name is an undefined symbol, the peripheral function register name may be used for extern declaration. To use a peripheral function register, delete the extern declaration and specify the register name using `#pragma ioreg`.

F4453: device file version mismatch, cannot use version *string*.

The specified device file version is illegal. The version *string* cannot be specified.

F4454: cannot link V850E(2) common objects with V850(E) objects. "file" is V850E(2) common object.

The files cannot be linked in the following combinations.

The file "file" is a V850Ex core common object file.

- V850E1/V850ES core common object files and V850 core object files
- V850E2 core common object files and V850 core object files
- V850E2 core common object files and V850E1/V850ES core object files

F4455: cannot link old_fcall objects with new_fcall object. "file" is old_fcall object

An object file that uses the new function call specifications cannot be linked with an object file that uses the old function call specifications. File *file* is an object file that uses the old function call specifications.

F4456: cannot link mask reg using objects with mask reg not using objects. "file" is mask reg using object.

An object file that uses the mask register cannot be linked with an object file that does not use the mask register. File *file* is an object file using the mask register.

F4457: input files have different BPC value.

Files with a different BPC values has been input.

W4504: cannot create output file "file".

Output file *file* cannot be created.

W4555: symbol "symbol" has incompatible type in file "file".

A link occurs in symbol *symbol* but the symbol has a different symbol type than the symbol having the same name defined in file.

W4556: symbol "symbol" has different size in file "file".

A link occurs in symbol *symbol* but the symbol has a different size than the symbol having the same name defined in file.

W4557: symbol "symbol" has different align-size in file "file".

A link occurs in symbol *symbol* but the symbol has a different alignment condition than the symbol having the same name defined in file.

W4562: size zero sbss or bss attribute symbol "symbol".

The size of symbol to be allocated to the sbss- or bss-attribute section is 0.

W4564: undefined global symbol *symbol* specified with "ext_func".

The global symbol *symbol*, specified by the .ext_func quasi directive, is not defined.

[Supplement]

The possible causes of this message are the following.

- (1) The function *symbol* is not defined.
- (2) The function *symbol* is specified as static.
- (3) The .ext_func quasi directive specified symbol is not described source of function defined.

In this case, branch instruction of function in branch table is unsolved.

W4605: section "section" with section type(*section type*) not supported, ignored.

The section with section name *section* having section type *section type* is not supported by the ld850. This entry is ignored.

W4608: input files have different register modes. use -rc option for more information.

A file with a different register mode has been input. Detailed information is output when the -rc option is

specified.

[Caution]

If an assembler file is included in the source file in a register mode other than the 32-register mode, this warning message may be displayed. To specify the register mode of an assembler file, use the `.option` quasi directive in the assembler file to specify the register mode. Enter the one of following descriptions in the assembler file.

When using 22-register mode:

```
.option reg_mode 5 5
```

When using 26-register mode:

```
.option reg_mode 7 7
```

W4611: "*string*" option overrides "*section*" section.

Section *section* is overwritten by the *string* option.

W4613: illegal flash mask option access (file: "*file*" address:*num1* bit:*num2*).

A function of the option byte which is prohibited from being set is set.

W4614: section "*section*" alignment must be 4 in internal instruction RAM.

Specify a multiple of 4 for the alignment condition of section *section* allocated in the internal instruction RAM.

W4615: section "*section*" attribute is illegal in internal ROM/internal instruction RAM.

Allocating section *section* having a write attribute in the internal ROM/RAM is illegal.

W4651: relocation entry in section "*section*" has unknown relocation type (*number*), ignored this entry.

The relocation entry in section *section* has an illegal relocation type *number*. This entry is ignored.

W4652: cannot find *number* th symbol table entry for relocation of reference at *offset(offset)* in "*section*" section, this relocation is ignored.

The *number*th symbol table entry to relocate a reference existing in *offset offset* of section *section* is not found. This relocation was ignored.

W4653: relocation entry in relocation section "*section1*" used to relocate section "*section2*" has illegal *r_offset(offset)*, ignored.

The entry in relocation information section *section1* used for relocation of section *section2* has illegal relocation *offset offset*. This entry is ignored.

W4655: cannot find GP-symbol in segment "*segment*" or illegal label reference for local symbol in file "*file2*"(section: *section2*, offset: *offset*, type: *relocation type*). local symbol is allocated in section "*section1*"(file: *file1*).

The GP symbol cannot be found in the segment *segment*. Or, there is a contradiction in the location/reference method of the local symbol.

[Supplement]

If a section to be located by #pragma section specification is changed by variable definition, change a section for the extern declaration of the variable in another file in the same way. The local symbol is located at *section1* of file *file1*. Reference to the local symbol exists at offset *offset* of section *section2* of file *file2*.

W4656: cannot find GP-symbol in segment "*segment*" or illegal label reference for symbol "*symbol*" in file "*file2*"(section: *section2*, offset: *offset*, type: *relocation type*). "*symbol*" is allocated in section "*section1*"(file: *file1*).

The GP symbol was not specified in the segment *segment*. Or, there is a contradiction in the location/reference method of the segment *segment*.

[Supplement]

If a section to be located by #pragma section specification is changed by variable definition, change a section for the extern declaration of the variable in another file in the same way. The symbol *symbol* is located at *section1* of file *file1*. Reference to the symbol *symbol* exists at offset *offset* of section *section2* of file *file2*.

W4657: cannot find GP-symbol in section "*section*" of file "*file1*" or illegal label reference for symbol "*symbol*" in file "*file2*"(section: *section2*, offset: *offset*, type: *relocation type*). "*symbol*" is allocated in section "*section1*"(file: *file1*).

GP symbol is not defined in section *section* of executable file *file1* at the boot side. Or, there is a contradiction in the location/reference method of the symbol *symbol*.

[Supplement]

If a section to be located by #pragma section specification is changed by variable definition, change a section for the extern declaration of the variable in another file in the same way. Symbol *symbol* is located at *section1* of file *file1*. Reference to symbol *symbol* exists at offset *offset* of section *section2* of file *file2*.

W4658: relocated value(*value*) of relocation entry(symbol: *symbol*, file: *file*, section: *section*, offset: *offset*, type: *relocation type*) for branch command become odd value.

The value *value*, relocated by a branch relocation entry (symbol *symbol*, file *file*, section *section*, offset *offset*, relocation type *relocation type*) is an odd number.

W4659: relocated value(*value*) of relocation entry (symbol: *symbol*, file: *file*, section: *section*, offset: *offset*, type: *relocation type*) for load/store command become odd value.

The value relocated by relocation entry (symbol *symbol*, file *file*, section *section*, offset *offset*, relocation type *relocation type*) of a load/store instruction is odd.

W4661: symbol "*symbol*" (output section *section1*) is too far from output section "*section2*". (value: *value*, file: *file*, input section: *section3*, offset: *offset*, type: *relocation type*).

The branch instruction from output section *section2* to the symbol *symbol* allocated to output section *section1* exceeds the branch destination range. The branch instruction exists at offset position *offset* for section *section3* in file *file*.

W4662: output section "*section1*" is too far from output section "*section2*". (value: *value*, file: *file*, input section: *section3*, offset: *offset*, type: *relocation type*).

The branch instruction from output section *section2* to the local symbol allocated to output section *section1* exceeds the branch destination range. The branch instruction exists at offset position *offset* for section *section3* in file *file*.

W4663: output section "*section1*" overflowed or illegal label reference for symbol "*symbol*" in file "*file2*" (value: *value*, input section: *section2*, offset: *offset*, type: *relocation type*). "*symbol*" is allocated in section "*section1*" (file: *file1*).

Output section *section1* overflowed. In addition, the section where symbol *symbol* was allocated and the label referencing method are illegal. *symbol* is allocated to *section1* by file *file1*. The illegal reference exists at offset *offset* for section *section2* of file *file2*.

W4664: output section "*section1*" overflowed or illegal label reference for local symbol in file "*file2*" (value: *value*, input section: *section2*, offset: *offset*, type: *relocation type*). local symbol is allocated in section "*section1*" (file: *file1*).

Output section *section1* overflowed. In addition, the section where a local symbol was allocated and the label referencing method are illegal. The local symbol is allocated to *section1* by file *file1*. The illegal reference exists at offset *offset* for section *section2* of file *file2*.

W4702: no archive symbol table, ignored this archive file.

An archive symbol table does not exist in the specified archive file. Specification of this archive file is ignored.

W4755: aligned odd value(*number1*) to be even value(*number2*).

Odd value *number1* is aligned to even value *number2*.

W4757: segment "*segment*" overflowed highest address of target machine.

The area to which segment *segment* is specified to be allocated exceeds the target machine's internal memory range.

[Supplement]

This message is changed to an error message by clearing `-Ximem_overflow=warning` option. This message can be erased by specifying the `-rom_less` option only if the cause of the warning is related to the internal ROM.

W4769: *string* in segment directive is illegal when "-r" option specified, ignored.
string must not be specified in the segment directive and is ignored if the -r or -ro option is specified.

W4770: *string* in section directive is illegal when "-r" option specified, ignored.
string must not be specified in the section directive and is ignored if the -r or -ro option is specified.

W4772: no LOAD segments exist for mapping input section "*section*" in file "*file*",
this section is mapped to non-LOAD *DUMMY* segment with no program header.
There are no LOAD segments for which section *section* can be mapped to in file *file*. This section is mapped to an unloadable dummy segment with no program header.

W4773: *string* is illegal in 1pass-mode, ignored, try in 2pass-mode ("-B" option).
string must not be specified in one-pass mode and is ignored. Use the -B option to specify two-pass mode.

W4774: *string* is illegal when "-f" option specified, ignored.
string must not be specified and is ignored when the fill value specification option (-f) is specified.

W4775: *string* symbol multiply defined to segment "*segment*", first defined symbol "*symbol*" used.
The *string* symbol is defined more than once for segment *segment*. The symbol *symbol* that is defined first is used as string symbol for segment *segment*.

W4777: *string* symbol multiply defined, first defined symbol "*symbol*" used.
The *string* symbol is defined more than once. The string symbol *symbol* that is defined first is used.

W4781: segment "*segment*" (*number1-number2*) must be in string-relative-address-able range (*number3-number4*).
The area to which segment *segment* is specified to be allocated (*number1-number2*) exceeds the range that can be referenced by string relative (*number3-number4*).

[Supplement]

If this message is output, the correct memory address may not be referenced. Be sure to change to the correct allocation when referencing a segment.

W4782: segment "*segment*" (*number1-number2*) overflowed highest or lowest address of internal memory (*number3-number4*).
The area to which segment *segment* is specified to be allocated (*number1-number2*) exceeds the target machine's internal memory range (*number3-number4*).

[Supplement]

This message is changed to an error message by clearing -Ximem_overflow=warning option. This message can be erased by specifying -rom_less option only if the cause of the warning is related to the internal ROM.

W4783: *string* specified in EP symbol directive, ignored.
string must not be specified in ep symbol directive and is ignored.

W4784: segment "*segment*" (*number1-number2*) overlaps guarded area (*number3-number4*).
The area to which segment *segment* is specified to be allocated (*number1-number2*) overlaps the guard (use prohibited) (*number3-number4*).

W4785: segment "*segment*" (*number1-number2*) overlaps programmable peripheral I/O area (*number3-number4*).

The area to which segment *segment* is to be allocated (*number1-number2*) overlaps the programmable peripheral I/O area (*number3-number4*).

W4788: section address specification is illegal when address of segment "*segment*" is not specified.

No address is specified for segment *segment*. If an address is specified for a section in a segment, specify an address also for the segment.

W4852: "*string*" option needs argument, ignored.

The string option needs an argument and is ignored.

W4854: "*string*" option is ignored.

The string option is ignored.

W4857: "*string1*" option is illegal when "*string2*" option is specified, ignored "*string1*" option.

The *string1* option must not be specified when *string2* option is specified. *string1* option is ignored.

W4860: "*string1*" option's argument is illegal, ignored "*string2*" option.

The argument specified for the *string1* option is illegal. *string2* and the specified option are ignored.

W4865: duplicated "*string*" option, ignored.

The string option has been specified two or more times. The specification is ignored.

W4866: duplicated "*string1*" option, ignored "*string2*" option.

The *string1* option has been specified two or more times. *string2* and the specified option are ignored.

W4867: duplicated "*string1*" option, ignored "*string2*" option.

The *string1* option has been specified two or more times. *string2* and the specified option are ignored.

W4868: "*string*" option aligned odd value(*value1*) to be even value(*value2*).

Odd value *value1*, specified for string option, was aligned with even value *value2*.

W4871: "*string*" option is not supported for V850 core.

string option is not supported by the device of the V850 core.

W4872: segment sort function is active, because new vector type exist in device file.

Segments are sorted in address order because a device file having a new interrupt type is specified. This message is output if an old link directive convention of CA850 Ver. 2.50 or earlier is specified by the `-Xolddir` option.

W4873: "*string*" option is not supported for this device.

The string option is not supported by the specified device. The specified option is ignored.

W4911: multiple inclusion of same file attempted, ignored.

The same file is specified more than once as an input file.

[Caution]

When PM+ is used, and if the assembler file of the startup file is registered as a source file and the object file of the startup file is specified by a linker option as a startup file, this warning message is output.

Take either of the following actions.

- (1) Delete the startup file from the source file registration, and specify a startup file as [\[Startup\]](#) tab on the [\[Compiler Common Options\] dialog box](#).
- (2) Create a dummy assembler file, assemble it and create ".o file", and specify it as [\[Startup\]](#) tab on the [\[Compiler Common Options\] dialog box](#).

B.1.5 ROMization process

F8400: b option needs argument.

The number of arguments for the -b option is not enough.

F8401: o option needs argument.

The number of arguments for the -o option is not enough.

F8402: p option needs argument.

The number of arguments for the -p option is not enough.

F8403: t option needs argument.

The number of arguments for the -t option is not enough.

F8404: F option needs argument.

The number of arguments for the -F option is not enough.

F8405: unknown option argument.

An argument that must not be specified for an option is specified.

F8406: -*option* unknown option.

Option *option* must not be specified.

F8407: b option is specified more than once.

-b option is specified more than once.

F8411: *file*: illegal input file name.

Input file *file* cannot be input because its file name is the same as an output file name.

F8412: illegal input file type, *file(file)* is archive file.

Input file *file* cannot be input because it is an archive file.

F8413: file bad magic.

Input file *file* cannot be input because it is illegal.

F8414: cannot open command file *file*.

Command file *file* cannot be opened.

F8415: nested command file *file*.

Command file *file* is nested.

It must not be nested.

F8416: file name *name* is too long.

The length of file name *name* exceeds the limit.

F8417: cannot find device file.

The device file cannot be found.

F8419: memory allocation fault.

The memory is insufficient.

F8420: *file*: illegal section type "*section*" specified with -p option.

Section *section* specified by the -p option in *file* has a section attribute that must not be specified for the -p option.

F8421: *file*: illegal section type "*section*" specified with -t option.

Section *section* specified by the -t option in *file* has a section attribute that must not be specified for the -t option.

F8422: address of *symbol* symbol must be same in all files.

The address of *symbol* must be the same in all input files.

F8423: *file*: not absolute object.

Relocatable object file *file* is specified as an input file.

F8424: *file*: "*symbol*" symbol not found.

Specified symbol cannot be found in object file *file*.

F8425: rompssec section overflowed highest address of target machine.

The upper limit of the memory was exceeded when rompssec section was created.

[Remarks]

(1) An warning message can be output by specifying -Ximem_overflow=warning option if an error occurs.

(2) This message can be deleted by specifying the -rom_less option.

F8426: *section1* section and *section2* section overlapped.

Sections *section1* and *section2* overlap.

F8427: processor type must be same in all files.

An illegal input file is specified.

F8428: symbol(*start_label*) must be word alignment.

Label *start_label* must be an address at a 4-byte boundary.

F8429: packing section not found.

The specified section cannot be found in the object file.

F8430: *section* section not found.

Section *section* specified by the -p option cannot be found.

F8432: illegal object file(*string*).

This is an illegal object file.

W8508: duplicated -*option1* option, ignored -*option2* option.

Option *option1* is specified more than once. Option *option2* is ignored.

W8509: section *section* is already defined by -p option and therefore this section is ignored.

Section *section* is ignored because it is already specified for the -p option.

W8510: *section* section is already defined by -t option and therefore this section is ignored.

Section *section* is ignored because it is already specified for the -t option.

W8518: @ option needs argument, ignored.

Option @ is ignored because the number of its arguments is not enough.

W8525: rompssec section overflowed highest address of target machine.

The upper limit of the memory was exceeded when rompssec section was created.

[Remark]

(1) This message can be deleted by specifying the -rom_less option.

W8533: *string* option needs argument, ignored.

The number of options for the *string* option is not enough. The option is ignored.

W8534: *string* option's argument is illegal, ignored.

The argument of the *string* option is illegal. The option is ignored.

B.1.6 Hexadecimal converter

F8600: too many input files

Two or more input files must not be specified.

F8601: too many output files

Two or more output files must not be specified.

F8602: illegal option *-character*

-character must not be specified as an option.

F8603: expect format type [ITSS] after *-f*

Specify I, T, S, or s after *-f*.

F8604: expect section name after *-l*

Specify a section name after *-l*.

F8605: expect block length after *-b*

Specify a block length after *-b*.

F8606: expect disp value after *-d*

Specify an offset value after *-d*.

F8607: expect input file

Specify an input file name.

F8608: expect output file after *-o*

Specify an output file name after *-o*.

F8609: expect device file path after *-F*

Specify a device file path after *-F*.

F8610: illegal use of *option* option

Option *option* is specified illegally.

F8611: nested command file *file*

Command file *file* is nested.

It must not be nested.

F8612: no section data exists in specified address area (*address1-address2*)

No section is in the area (*address1-address2*) specified by the *-U* option.

F8613: file name *name* is too long

The length of file name *name* exceeds the limit.

F8620: cannot open file *file*

File *file* cannot be opened.

F8621: cannot open output file *file*

Output file *file* cannot be opened.

F8622: cannot get *section* section

Section *section* cannot be found.

F8623: cannot find device file

The device file cannot be found.

F8624: cannot find device information

Information of the device cannot be found.

F8625: *file* is not ELF file

File *file* is not an object file in the ELF format.

F8626: *file* is archive file

File *file* is an archive file. No archive file can be specified.

F8627: illegal target machine type

The type of the target machine is illegal.

F8628: illegal object file(*string*)

The object file is illegal.

F8629: cannot create HEX rom data, because there is no memory information

ROM data cannot be created because memory information is missing.

F8630: *section* section overflowed lowest address of internal memory

Section *section* falls below the lower limit of the internal ROM area or the area specified by the -U option.

F8639: *section*: no such section

Specified section *section* cannot be found.

F8640: illegal block length *length*

The value *length* of the block length specified by the -b option is illegal.

F8641: illegal disp value *value*

The value *value* of the offset specified by the -d option is illegal.

F8642: illegal fill value

The fill value specified by the -U option is illegal.

F8643: illegal start address value

The value *value* of the start address specified by the -U option is illegal.

F8644: illegal size value *value*

The value *value* of the size specified by the -U option is illegal.

F8645: size must not be 0

The size specified by the -U option must not be 0.

F8646: memory allocation fault

The memory is insufficient.

W8713: file name *name* is too long

The length of file name *name* exceeds the limit.

W8714: expect command file after @, ignored.

Specify a command file after @. Option @ is ignored.

W8715: *section* section is already defined by -l option, ignored.

Section *section* is ignored because it has already been specified by the -l option.

W8716: -S and -x expect -fT

Options -S and -x are valid only when the extended Tektronix hex format is specified.

W8717: -S expect -fT

Option -S is valid only when the extended Tektronix hex format is specified.

W8718: -x expect -S and -fT

Option -x is valid only when it is specified together with options -S and -fT.

W8719: *option1* option overrides *option2* option

Option *option2* is invalid because option *option1* is specified.

W8730: *section* section overflowed lowest address of internal memory

Section *section* falls below the lower limit of the internal ROM area or the area specified by the -U option.

W8731: *section* section overflowed highest address of internal memory

Section *section* exceeds the range of the internal memory space.

W8732: *section* section overflowed lowest address of program memory

Section *section* falls below the lower limit of the program memory.

W8733: *section* section is converted from its midst

Hex conversion is performed from the specified address in the middle of section *section*.

W8734: *section* section is converted until its midst

Hex conversion is performed to the specified area in the middle of section *section*.

W8735: The address of convert area exceeds the maximum value of the address that can be expressed in the Intel expanded hex format

The address exceeds the maximum value (20 bits) of an address that can be expressed in the Intel extended hex format. Processing is continued with the range that can be expressed output as addresses.

[Supplement]

The possible causes of this message are the following.

(1) ROMization was skipped.

It is possible that an attempt was made to execute hex conversion of a section in internal RAM together with a section allocated to ROM. Execute ROMization before hex conversion.

(2) Wrong section is specified for hex conversion.

The addresses of the sections that are to be converted into the hex format at the same time may be widely apart. If two or more ROMs are used, execute hex conversion on each ROM. Check if the section to be converted into hex format is correct and if the allocation address of the section is correct.

(3) The section itself is too large.

If the area to be converted into hex format is too large and the range that can be expressed is exceeded, hex conversion cannot be executed. Either divide the area into segments within the range that can be expressed, or use another hex format.

[Caution]

Although the maximum value of an address is 20 bits, it is actually around 20 bits. The 20-bit address expression in the Intel extended hex format that causes this message to be output is calculated from the extended address record having a higher address and a data record having an offset from that higher address. If the higher address of the extended address record fits in 20 bits, output is normal as the Intel extended hex format and no error occurs even if the result of adding the offset of the data record exceeds 20 bits.

W8736: The address of convert area exceeds the maximum value of the address that can be expressed in the Motorola S type hex format (standard address).

The address exceeds the maximum value (24 bits) of an address that can be expressed in the Motorola S type hex format (standard address). Processing is continued with the range that can be expressed output as addresses.

[Supplement]

The possible causes of this message are the following.

- (1) ROMization was skipped.

It is possible that an attempt was made to execute hex conversion of a section in internal RAM together with a section allocated to ROM. Execute ROMization before hex conversion.

- (2) Wrong section is specified for hex conversion.

The addresses of the sections that are to be converted into hex format at the same time may be widely apart. If two or more ROMs are used, execute hex conversion on each ROM. Check if the section to be converted into hex format is correct and if the allocation address of the section is correct.

- (3) The section itself is too large.

If the area to be converted into hex format is too large and the range that can be expressed is exceeded, hex conversion cannot be executed. Either divide the area into segments within the range that can be expressed, or use another hex format.

W8737: The start address of convert area exceeds the maximum value of the address that can be expressed in the Intel expanded hex format.

The first address exceeds the maximum value (20 bits) of the address that can be expressed in the Intel extended hex format. Processing is continued with the range that can be expressed output as addresses.

[Supplement]

The possible causes of this message are the following.

- (1) The address of the section is too large.

The address where the section is allocated may exceed the range that can be expressed. Specify the start address of the area to be converted into hex format, by using the -d option, and use an offset from that address.

- (2) The value specified by the -d option is incorrect.

By specifying the -d option, an offset from a value specified as an address can be used. The offset from this value may exceed the range that can be expressed. Specify an appropriate value.

W8738: The start address of convert area exceeds the maximum value of the address that can be expressed in the Motorola S type hex format (standard address).

The start address exceeds the maximum value (24 bits) of the address that can be expressed in the Motorola S type hex format (standard address). Processing is continued with the range that can be expressed output as addresses.

[Supplement]

The possible causes of this message are the following.

(1) The address of the section is too large.

The address where the section is allocated may exceed the range that can be expressed. Specify the start address of the area to be converted into hex format, by using the -d option, and use an offset from that address.

(2) The value specified by the -d option is incorrect.

By specifying the -d option, an offset from a value specified as an address can be used. The offset from this value may exceed the range that can be expressed. Specify an appropriate value.

W8747: too small block length. Length => *length*

The maximum value of the specified block length is too small. It is changed to the default value, *length*, and processing is continued.

W8748: too large block length. Length => *length*

The maximum value of the specified block length is too large. It is changed to the maximum value, *length*, of the value that can be specified, and processing is continued.

W8749: block length is set. Length => *length*

The maximum value of the block length is changed from the default value to *length* and processing is continued. This message is output if a value that must not be specified for the -b option is specified.

W8750: symbol block length exceed default value

The block length of the symbol block exceeds the maximum value of the specified block.

B.1.7 Archiver

F8200: memory allocation fault

The memory is insufficient.

F8201: bad key *character* -- use [dm(a|b)qr(a|b|u)txV]

character must not be specified as a key.

F8202: bad option *character* -- use [cv]

character must not be specified as an option.

F8203: bad option *string*

string must not be specified as an option.

F8204: can not create file *file*

File *file* cannot be created.

F8205: file name *name*... is too long

The length of file name *name* exceeds the limit.

F8206: can not open file *file*

File *file* cannot be opened.

F8207: can not close file *file*

File *file* cannot be closed.

F8208: can not read file *file*

Nothing can be read from file *file*.

F8209: can not write file *file*

Nothing can be written to file *file*.

F8210: can not seek file *file*

File *file* cannot be sought.

F8212: can not nest command file *file*

Command file *file* is nested.

It must not be nested.

F8213: *file* is not archive file

File *file* is not an archive file.

F8214: malformed archive file *file*

The contents of archive file *file* may have been lost.

F8215: can not find member *member*

Member *member* does not exist in the archive file.

F8216: symbol table limit error *file* (*number1*) -- limit is *number2*

The number of symbols *number1* in archive file *file* exceeds the limit. The limit value is *number2*.

F8217: symbol table error *file*

The contents of the archive string table in archive file *file* may have been lost.

F8218: string table error *file*

Creating an archive symbol table in archive file *file* has failed.

F8219: *file* has no member

No member exists in archive file *file*.

F8220: version error *file*

The version of the format of specified file *file* is not a version that can be handled by this archiver.

F8221: can not read archive header *file*

The header of archive file *file* cannot be read.

W8306: can not open file *file*

File *file* cannot be opened.

W8307: can not close file *file*

File *file* cannot be closed.

W8308: can not read file *file*

Nothing can be read from file *file*.

W8309: can not write file *file*

Nothing can be written to file *file*.

W8310: can not seek file *file*

File *file* cannot be sought.

W8311: can not find file *file*

File *file* cannot be read.

W8315: can not find member member

Member member does not exist in the archive file.

W8322: this symbol offset not true

The symbol offset of the archive file is illegal.

B.1.8 Section file generator

F8000: cannot open output file *file*

Output file *file* cannot be created.

F8010: cannot open input file *file*

Input file *file* cannot be opened.

F8020: cannot write file '*file*'

Nothing can be written to output file *file*.

F8030: unknown option *option*

Option *option* that is not an option of the sf850 is specified.

F8040: -cl level out of range (0 - 2)

A wrong value is specified by the -cl option.

F8050: *option* option need sub argument

An argument is necessary for option *option*.

F8080: not enough memory

The memory is insufficient.

W8101: cannot calculate *name*'s frequency

The frequency of use of variable *name* cannot be calculated. This message is output when the variable is not used and when the -v option is specified. This warning message may be ignored.

W8111: you use -O option, sorting option ignored

A sorting option and the -O option are specified at the same time. The sorting option is ignored.

W8121: unrecognized option *option*, ignored

Option *option* is ignored because it cannot be recognized.

B.1.9 Dump command

F9001: can not open file *file*

File *file* cannot be opened.

F9003: nested command file *file*

Command file *file* is nested.

It must not be nested.

F9024: memory allocation error

The memory is insufficient.

W9102: illegal object file(*string*)

The object file is incorrect.

W9121: buffer number error

The buffer number is incorrect.

W9122: illegal option *-c*

-c must not be specified as an option.

W9123: illegal option *+c*

+c must not be specified as an option.

W9125: not enough argument

The number of arguments is insufficient.

W9126: not enough argument for string

The number of arguments for option string is insufficient.

F9127: Size error

The size is incorrect.

B.1.10 Disassembler

F8801: bad magic file *file*

The specified *file* is not an object file of the V850 microcontrollers.

F8802: cannot find device file

The device file cannot be found.

F8803: cannot open file *file*

File *file* cannot be opened.

F8804: illegal object(*string*)

The object file is incorrect.

F8805: nested command file *file*

Command file *file* is nested.

It must not be nested.

F8821: memory allocation error

The memory is insufficient.

B.1.11 Cross reference tool

F9600: %s

Error detected.

F9601: '%s' can't open

File failed to open.

F9602: '%s' can't seek

File seek failed.

F9603: '%s' can't read

File read failed.

F9604: '%s' can't write

File write failed.

F9605: no memory

Memory securement failed.

F9606: '%s' not found

Preprocessor cannot detect file %s.

F9607: '%s' failed

Preprocessor has detected error in file %s.

F9608: input file nothing

Input file not specified.

F9609: '%s' not specified file name

File name not specified by option %s.

F9610: '%s' not specified identifier

Identifier not specified by option %s.

F9611: '%s' not specified symbol

Symbol not specified by option %s.

F9612: '%s' range over

Value beyond range specified in option %s.

F9613: '%s' not specified path

Path not specified in option %s.

F9614: multiple declaration function '%s'

Function name %s redundant.

W9651: '%s' invalid option, ignored

Invalid option %s specified.

W9652: too long identifier '%s...' [%d]

Identifier %s exceeds %d characters

W9653: specified function '%s' not found

No description related to specified function %s.

W9654: section not found in '%s'

No description related to section in file %s specified by -file=%s.

W9655: DefinitionType section not found in '%s'

No description related to DefinitionType section in file %s specified by -d=%s.

W9656: Ignoreldent section not found in '%s'

No description related to Ignoreldent section in file %s specified by -i=%s.

W9657: NoIncludeFile section not found in '%s'

No description related to NotIncludeFile section in file %s specified by -ni=%s.

C9690: %s

Compile error %s generated.

C9691: null pointer access

Access to NULL pointer attempted.

C9692: index out of range

Access beyond array range attempted.

B.1.12 Memory layout visualization tool

F9700: %s

Error detected.

F9701: '%s' can't open

File failed to open.

F9702: '%s' can't seek

File seek failed.

F9703: '%s' can't read

File read failed.

F9704: '%s' can't write

File write failed.

F9705: no memory

Memory securement failed.

F9706: '%s' is not ELF executable file

File %s not ELF executable format.

F9707: input file nothing

Input file not specified.

F9708: too many files

File to be analyzed is redundantly specified.

F9709: Executable file does not provide symbol information

Symbol table does not exist for file to be analyzed.

F9710: Executable file does not provide data-object information

No variable exists for file to be analyzed.

F9711: '%s' not found range

Range not specified by -r option.

F9712: '%s' invalid range

Value beyond option range specified by -r option.

F9713: '%s' invalid end-address

End address specified by -r option illegal.

F9714: '%s' not spevified path

Output path not specified by -r option.

F9715: '%s' not specified file name

Output file not specified by -r option.

W9751: '%s' invalid option, ignored

Invalid option %s specified.

C9790: %s

Compile error %s generated.

C9791: null pointer access

Access to NULL pointer attempted.

C9792: index out of range

Access beyond array range attempted.

B.2 Messages from PM+

This section explains the message dialog box that is displayed when the CA850 package is activated from PM+.

B.2.1 Format of message

The message dialog box shown in [Figure B - 1](#) displays messages when the CA850 package is activated from PM+.

Figure B - 1 Example of Message Dialog Box

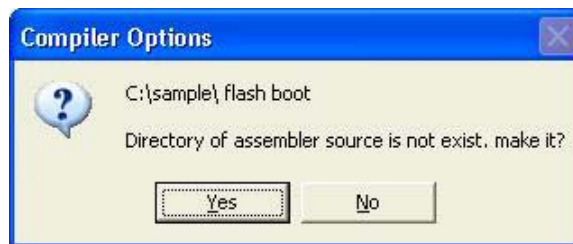

B.2.2 Messages common to compiler

'Boot Object File' is illegal.

Do not use blanks in the file name of a boot object file.

'Branch Table Address' is illegal.

Do not use any characters other than hexadecimal numbers in the address of a branch table.

'Link Directive File' is illegal.

Do not use blanks in the file name of a link directive file.

'Security ID' is illegal.

Do not use characters other than hexadecimal numbers in a security ID. Or, the security ID exceeds the prescribed range.

The final output folder does not exist. Check if a folder should be created.

'Startup File' is illegal.

Do not use blanks in the file name of the startup file. Or, do not use a file name that is the same as the source file name of the startup file, excluding the extension, in the source file list.

'Value of BPC Register' is illegal.

Do not use any characters other than integers for the BPC register. Or, the value of the BPC register exceeds the prescribed range of the device.

'rompct File' is illegal.

Do not use blanks in the file name of the rompct file. Or, do not use a file name that is the same as the source file name of the rompct file, excluding the extension, in the source file list.

Final output directory is not exist. make it?

Intermediate output directory is not exist. make it?

The intermediate output folder does not exist. Check if a folder should be created.

The extension of the file does not exist.

Build might not be executed correctly.

An extension is necessary for a file name. Without an extension, build processing may not be executed correctly.

cannot create directory

The folder cannot be created.

B.2.3 Compiler

'Code Size Threshold of Automatic Inline Expansion' is illegal.

Do not use any characters other than numerals as the upper limit of the size of a code to be expanded inline.

'Far Jump File Name' is illegal.

Do not use blanks in the file name of a Far Jump file.

'Limit of Number of Error' is illegal.

Do not use any characters other than numerals as the upper limit of the number of errors.

'Limit of Number of Macro' is illegal.

Do not use any characters other than numerals as the upper limit of a macro.

'Number of Loop Unrolling' is illegal.

Do not use any characters other than numerals as the number of times a loop is to be expanded.

'Section File Name' is illegal.

Do not use blanks in the file name of a section file.

'Sort External Variable' is illegal.

Do not use the same file name excluding the extension, illegal characters in the extension, and comma in the name of a file that sorts external variables.

'Stack Size Threshold of Automatic Inline Expansion' is illegal.

Do not use any characters other than numerals as the upper limit of the size of a stack to be expanded inline.

'sconst Allocation Size Threshold' is illegal.

Do not use any characters other than numerals in the specification of the length of data to be allocated to sconst.

'sdata/sbss Allocation Size Threshold' is illegal.

Do not use any characters other than numerals in the specification of the length of data to be allocated to sdata/sbss.

Directory of assembler source is not exist. make it?

The folder of the assembly language source does not exist. Check if a folder should be created.

Directory of assemble list is not exist. make it?

The folder of the assembler list does not exist. Check if a folder should be created.

Directory of frequency information file is not exist. make it?

An extension is necessary for a file name. Without an extension, build processing may not be executed correctly.

Do you want to set your changed option for sources?

Check if all the modification contents of an individual source option are to be reflected in the source.

Temporary Directory is not exist. make it?

The temporary folder does not exist. Check if a folder should be created.

The extension of the file does not exist.

Build might not be executed correctly.

An extension is necessary for a file name. Without an extension, build processing may not be executed correctly.

cannot create directory

The folder cannot be created.

cannot use semicolon

Do not use ";" (semicolon) for an option for which two or more items can be input.

B.2.4 Assembler

'sdata/sbss Allocation Size Threshold' is illegal.

Do not use any characters other than numerals as the length of data to be allocated to sdata/sbss.

Do you want to set your changed option for sources?

Check if all the modification contents of an individual source option are to be reflected in the source.

cannot use semicolon

Do not use ";" (semicolon) for an option for which two or more items can be input.

B.2.5 Linker

'Filling Number of Hole' is illegal.

Do not use any characters other than hexadecimal numbers as the filling value of a hole.

'Output File' is illegal.

Do not use romp.out, illegal characters in the extension, and blanks in an output file name.

'Startup File' is illegal.

Do not use a file name that is the same as the source file name of the startup file, excluding the extension, in the source file list. The default startup file is specified.

'rompcrt File' is illegal.

Do not use a file name that is the same as the source file name of the rompcrt file, excluding the extension, in the source file list. The default rompcrt file is specified.

This project does not need boot object file.

The boot object file is not necessary for a project for which a flash-supporting object is not specified.

This project does not need rompcrt file.

The rompcrt file is not necessary for a project for which ROMization is not specified.

You cannot delete your selected file from this project.

The startup file and rompcrt file cannot be deleted from a project.

cannot use semicolon

Do not use ";" (semicolon) for an option for which two or more items can be input.

B.2.6 ROMization processor

'Output File' is illegal.

Do not use a.out, illegal characters in the extension, and blanks in an output file name.

In ROM section file, same macro name is exist.

Do not use the same macro name in the ROMization section file. The file cannot be output correctly.

Output of ROM section file is faild.

The ROMization section file has not been output correctly.

Output of ROM section file is succeeded.

The ROMization section file has been output correctly.

cannot use semicolon

Do not use ";" (semicolon) for an option for which two or more items can be input.

B.2.7 Hexadecimal converter

'Filling Number of ROM Area' is illegal.

Do not use any characters other than hexadecimal numbers or a value exceeding the range as the filling value of a ROM area.

'Maximum Length of Block/Record' is illegal.

Do not use any characters other than decimal numbers or a value exceeding the range as the maximum length of a block or record.

'Offset of Output Address' is illegal.

Do not use any characters other than hexadecimal numbers or decimal numbers as the offset of an address to be output.

'Output File' is illegal.

Do not use illegal characters in the extension and blanks in an output file name.

'Size of ROM Area' is illegal.

Do not use any characters other than hexadecimal numbers or a value exceeding the range as the size of a ROM area.

'Start Address of ROM Area' is illegal.

Do not use any characters other than hexadecimal numbers or a value exceeding the range as the start address of a ROM area.

cannot use semicolon

Do not use ";" (semicolon) for an option for which two or more items can be input.

B.2.8 Archiver

'Archive File' is illegal.

Do not use an illegal character in the extension and blanks in an archive file name.

B.2.9 Section file generator

'Allocatable Size of tidata Section' is illegal.

Do not use any characters other than decimal numbers as the allocation size of the tidata section.

'Allocatable Size of tidata.byte Section' is illegal.

Do not use any characters other than decimal numbers as the allocation size of the tidata.byte section.

'Output File' is illegal.

Do not use illegal characters in the extension and blanks in an output file name.

The extension of the file does not exist.

Build might not be executed correctly.

An extension is necessary for a file name. Without an extension, build processing may not be executed correctly.

cannot open device file

The device file cannot be opened correctly.

B.2.10 Cross reference tool and memory layout visualization tool

F102: Reading the specified file has failed.

The name of the file in which an error has occurred is displayed because reading the specified file has failed. Check that the specified file has not been damaged.

F106: The specified folder does not exist and is not created. Do you want to create it?

The specified folder does not exist.

F107: The specified folder was not found. Check that the correct folder name has been specified.

The specified folder was not found. Check the folder name and specify the correct folder name.

F108: Creating the specified folder has failed. Check that the correct folder name has been specified.

Creating the specified folder has failed. Check the specified folder and specify the correct folder.

F109: The specified file could not be opened. Select an application to open the file using Explorer.

An attempt was made to display the analysis result but executing the program failed because the program was not associated. Associate the program using Explorer.

F110: The specified file is a ReadOnly file. Save the data to another file.

The project file specified when it was saved has a ReadOnly attribute. Save the data to another file, or clear the ReadOnly attribute and then save it to that file.

F120: A file to be analyzed is not specified.

A file to be analyzed is not specified. Specify a file.

F121: An output file is not specified. Specify the format and name of the file to be output, by using "Detailed Option Setting".

The type and name of the file to which the analysis result is to be output are not specified. Set an output file by using "Detailed Option Setting".

F122: xxxx is illegal. Input a value up to yyyy.

The specified value is outside the range. Or, a symbol was input. xxxx indicates the name of the edit box on which the illegal value is set, and yyyy indicates the range of values that can be input. Input a correct value.

F123: The start address is illegal. Input a value in a range of 0 to 0xffffffff.

The specified start address is incorrect. Input a correct value.

F124: The end address is illegal. Input a value in a range of 0 to 0xffffffff.

The specified end address is incorrect. Input a correct value.

F125: The address range is invalid.

The specified address range is incorrect. Input a correct value.

F126: Analysis result has failed. Do you want to open the log file?

Analysis has failed. Open the log file to identify the cause of the error, take corrective action, and then execute analysis again.

F128: Specify the name of a file to read the function name.

Analysis has failed. No file to read the function name is specified. Specify a file.

F129: Specify an output file name.

No output file name is specified. Specify a file.

F130: The output range is not set. The entire output range will be set. OK?

An output range of the RAM map is not specified. Set an output range of RAM map or select output of the entire range.

F131: Specify the name of a file to read identifier names.

A file to read identifier names is not specified by a cross reference option. Specify a file.

B.3 Messages from stk850

This section describes the messages output by the stk850.

B.3.1 Message formats

The stk850 messages are displayed in the message display area in the following formats.

Table B - 1 Formats of Messages Output by stk850

Number	Description
E93xx	Error message
W940x	Warning message for all the files
W941x, W942x	Stack size specification file related warning messages
W943x	Intermediate assembly language file related warning message
W945x	Output file related warning messages
W946x	Stack size specification related warning message
I95xx	Confirmation message

B.3.2 Messages

E9300: Cannot find project file(*path*).

The specified project files is not found. Check that the file exists.

E9301: Cannot open file(*path*). Check the properties.

This message appears when the project file or the stk system file is prohibited from being read, or when a folder is specified in the *path*.

E9302: Illegal format at line(*line:string*) in file(*path*). Check the file.

line:string in the file is an incorrect format. This message appears when an incorrect format is found in the project file or the stk system file.

E9303: Failed to invoke file(*path*).

The stk850 did not start. This message appears when exe did not start from the DLL. The message means installation was executed unsuccessfully or the exe file has been corrupted. Reinstallation is required.

W9400: Cannot find file(*path*). Check that the specified file name is correct.

The specified file cannot be found. Specify the correct file name.

W9401: Cannot open file to read(*path*). Check that the file is readable.

The file is prohibited from being read. Enable the file read.

W9402: Cannot open file to write(*path*). Check that both the file and the folder are writable.

The file is a read-only file. Set a write enable attribute to the file or the folder.

W9404: File write error(*path*).

An error occurred while the file was written. Check that writing files is enabled.

W9405: Too many characters in one line in file(*path:line line*). The limit is *num*.

The file (*path:line*) exceeds the maximum number of characters per line (*num*).

For the upper limit value of each file, refer to "[14.5.1 Quantitative limit of the stk850](#)".

W9406: Too many lines in file(*path:line*). The limit is *num*.

The file (*path:line*) exceeds the maximum number of lines per file (*num*).

For the upper limit value of each file, refer to "[14.5.1 Quantitative limit of the stk850](#)".

W9407: Too long file name(*path*). The limit is 255.

The file name (*path*) is too long. A file whose name contains 255 characters or more cannot be used.

W9408: Illegal file format(*path:line line*) as *type*.

The specified file is not correct as *type*. Specify the correct file. This message appears when the project file specified in the menu after the stk850 starts is incorrect, the stk system file is incorrect, or an incorrect file is specified as a stack size specification file.

W9410: Unknown function name(*function*) in file(*path:line line*). Only functions explicitly referred to in the project are allowed.

In the stack size specification file, a setting for a function (*function*) that is not used in the project was found. Check the function name. A [\[Do you want to stop reading?\] Dialog Box](#) is output.

Table B - 2 [\[Do you want to stop reading?\] Dialog Box](#)

Button	Description
Stop	To stop reading.
Restart	To ignore the error line and start reading the next line.
Ignore	To ignore the error line and start reading the next line. Display of the dialog box is suppressed for subsequent warnings (W9410 to W9426); however the warnings are output to the message display area.

W9411: Too long file name qualifying static function name in file(*path:line line*).

The limit is 255.

In the stack size specification file, a file name for which a static function is declared and which is too long was found. Reduce the number of characters to 255 or less. The [\[Do you want to stop reading?\] Dialog Box](#) is output.

W9412: Too long callee function name in file(*path:line line*). The limit is 1022.

In the stack size specification file, a function name that is too long to be specified as a callee function was found. Reduce the number of characters to 1022 or less. The [\[Do you want to stop reading?\] Dialog Box](#) is output.

W9413: Illegal value(*value*) after "ADD=" in file(*path:line line*).

In the stack size specification file, specification of an incorrect additional margin was found. Specify the addition margin as follows: "ADD=" followed by a non-negative decimal number or a hexadecimal number that starts with "0x".

For details, refer to "[14.6.2 Stack size specification file](#)". The [\[Do you want to stop reading?\] Dialog Box](#) is output.

W9414: Multiple "ADD="s for one function in file(*path:line line*). Only one is allowed for one function.

In the stack size specification file, multiple specifications of additional margin for one function were found. Only one can be specified for one function.

For details, refer to "[14.6.2 Stack size specification file](#)". The [\[Do you want to stop reading?\] Dialog Box](#) is output.

W9415: Illegal value(*value*) after "RECTIME=" in file(*path:line line*).

In the stack size specification file, an incorrect value for recursion depth was found. Specify the recursive depth as follows: "RECTIME=" followed by a positive decimal number or a hexadecimal number that starts with "0x".

For details, refer to "[14.6.2 Stack size specification file](#)". The [\[Do you want to stop reading?\] Dialog Box](#) is output.

W9416: Multiple "RECTIME="s for one function in file(*path:line line*). Only one is allowed.

In the stack size specification file, multiple specifications of recursion depth were found. Only one can be specified for one function.

For details, refer to "[14.6.2 Stack size specification file](#)". The [\[Do you want to stop reading?\] Dialog Box](#) is output.

W9417: Illegal "RECTIME=" for non-recursive function in file(*path:line line*). It shall be specified for recursive functions.

In the stack size specification file, an incorrect specification of recursion depth was found.

"RECTIME=" (specification of recursion depth) can be used only for recursive functions.

For details, refer to "[14.6.2 Stack size specification file](#)". The [\[Do you want to stop reading?\] Dialog Box](#) is output.

W9418: Missing function name after "CALL=" in file(*path:line line*).

In the stack size specification file, an incorrect specification of a callee function incorrect counting information was found. Specify the callee function as follows: "CALL=" followed by the function name. The function names that are not defined or called explicitly in the project cannot be registered.

For details, refer to "[14.6.2 Stack size specification file](#)". The [\[Do you want to stop reading?\] Dialog Box](#) is output.

W9419: Multiple function names after "CALL=" in file(*path:line line*). Place "CALL=" before each functions

In the stack size specification file, an incorrect specification of a callee function was found. Only one function can be specified after "CALL=". When specifying multiple callee functions, specify multiple number of "CALL=".

For details, refer to "[14.6.2 Stack size specification file](#)". The [\[Do you want to stop reading?\] Dialog Box](#) is output.

W9424: Multiple specifications for one function in file(*path:line:line1, line:line2*). Only one is allowed.

In the stack size specification file, specification for the same function was found in *line1* and *line2*. Delete the specification in either one of the lines.

For details, refer to "[14.6.2 Stack size specification file](#)". The [\[Do you want to stop reading?\] Dialog Box](#) is output.

W9425: Too many characters in one line in file(*path:line line*). The limit is *num*.

The file (*path:line*) exceeds the maximum number of characters per line (*num*). Accordingly, reduce the number of characters in one line.

For details, refer to "[14.5.1 Quantitative limit of the stk850](#)". The [\[Do you want to stop reading?\] Dialog Box](#) is output.

W9427: Cannot find stack size specification file for system library functions(*path*). Default values (as same as libsize32.txt) are used.

The stack size specification file (*path*) for the standard library was not found. The stk850 uses the default information (which is the same as libsize32.txt). Installation may have been executed unsuccessfully.

W9430: Cannot find CA850 generated assembly language source file. Select PM+'s menu([Tool]-[Compiler Options]) and check "Assembler Source" in [General] tab.

The intermediate assembler file cannot be found. Register the C language source file in PM+, specify the "[Assembler Source\[-Fs\]](#)" in the [\[General\]](#) tab of the [\[Compiler Options\] dialog box](#), and then rebuild.

W9450: Number of lines reached limit(32767) in output.

The output result contains more than 32767 lines. Change the selection of the function or output only the call chain with maximum stack.

W9451: Number of characters in one line reached limit(5119) in output.

A line of the output result contains more than 5119 characters. Change the selection of the function or output the result in the text format, in which the line is split into two or more lines.

W9460: Too many callee functions. The limit is 1024.

The number of callee functions for one function exceeds 1024. Reduce the number of them. Even if all the callee functions are registered, only the function whose stack size becomes the maximum is added to the stack size.

W9461: Too many characters in specification for one function. The limit is 5119.

The number of characters per line exceeds 5119. Reduce the number of the callee functions. The 5119 characters include parameter names and separators.

W9462: Illegal value(*character*) for additional margin.

The additional margin includes an incorrect character. Specify a non-negative decimal number or a hexadecimal number that starts with "0x".

W9463: Illegal value(*character*) for recursion depth.

The recursion depth includes an incorrect character. Specify a positive decimal number or a hexadecimal number that starts with "0x".

W9464: Too big additional margin. The limit is 2147483647.

A value greater than 2147483647 is specified as the additional margin. Specify a value smaller than 2147483647.

W9465: Total stack size exceeds 2147483647 in function(*function*). Reduce recursion depth.

The amount of the stack to be used in the function exceeds 2147483647. Reduce the value of the recursion depth.

W9466: Total stack size exceeds 2147483647 in function(*function*). Reduce stack size in the maximum call chain.

The amount of the stack to be used in the function exceeds 2147483647. Reduce the stack size of functions in the call chain with maximum stack.

I9500: Exit stk850.

Click the [OK] button to endexit the stk850.

I9501: Do you want to overwrite it?

Click the [Yes] button to overwrite the existing file.

Click the [No] button to cancel.

I9502: Do you want to cancel adjustments to the selected function(*function*)?

Click the [Yes] button to cancel adjustments to the selected function.

Click the [No] button to do nothing.

I9503: Do you want to cancel adjustments to all functions?

Click the [Yes] button to cancel adjustments to all functions.

Click the [No] button to do nothing.

APPENDIX C INDEX

Numerics

256M Byte Mode ... 76

A

-A ... 194
[About stk850] dialog box ... 396
[Adjust Stack Size] dialog box ... 392
ANSI ... 57, 88
[Archive File Options] dialog box ... 303
Archive Files ... 197
Archive Header ... 304
Archive String Table ... 304
Archive Symbol Table ... 304
Archiver ... 263
 Keys ... 266
 Operation Method ... 264
 Options ... 268
Archiver Options ... 269
[Archiver Options] dialog box ... 269
Assemble List ... 83, 99, 138, 143
[Assembler] ... 107
Assembler ... 124
 Device ... 131
 File ... 128
 Flow of Operation ... 124
 Input/Output Files ... 125
 Option ... 129
 Other ... 133
Assembler Options ... 136
[Assembler Options] dialog box ... 136
Assembler Source ... 82, 98

B

Bit Field ... 88
Boot Object ... 75
BPC ... 76
Branch Instruction ... 48
Branch Table ... 75

C

[C Language] ... 88
C++ Style Comment ... 87
Call database ... 363
[Call graph] ... 346
Call tree ... 357
CC78K ... 88
char ... 88
Coding Format ... 24
Command File ... 62, 110, 116
Comment ... 56, 83
[Common option] ... 341, 376
Compiler Common Options ... 69
[Compiler Common Options] dialog box ... 69
Compiler Options ... 80
[Compiler Options] dialog box ... 80
Compiler Package ... 20
Copy routine ... 218
[Cross reference] ... 337

Cross reference ... 331, 353
[Cross reference list] ... 344
Cross reference Option ... 340
[Cross reference Option] dialog box ... 340
Cross Reference Tool ... 323
 Call Database ... 335
 Call tree ... 333
 Common options ... 328
 Function Metrics ... 334
 Input File ... 324
 Operation Method ... 326
 Output Information ... 325
 Tag information ... 332

D

Debug Information ... 82, 108, 138, 175, 309
Define Macro ... 83, 87, 107, 138
Delete Source Option ... 83
[Detail of Optimization] ... 92
[Device] ... 76
Device Specification ... 38
[Difference] ... 111, 141
[Disassembler] ... 318
Disassembler ... 313
 Operation Method ... 314
 Options ... 315
 Output Format ... 322
[Dump] ... 298
Dump Command ... 293
 Operation Method ... 294
 Options ... 295
Dump List ... 304

E

[Edit Option] dialog box ... 113
ELF Header ... 305, 310, 407
Entry Label ... 235
enum ... 88
Error File ... 70
Error Output ... 43
Executable Object ... 30
Expanded Tek ... 259
[External Register] ... 96
External Symbol ... 176
External Variable Register ... 97
External Variable Sort ... 48
.ext_func quasi directive ... 185

F

Far Jump ... 56, 84
[File] ... 70, 171, 232, 248, 288
Filling Number of Hole ... 174
Final Output Directory ... 70
[Flash] ... 75, 79
Flash Memory ... 181
Flash ROM ... 162
Folder Organization ... 24
Format ... 249

- Format of Object File ... 406
 - Frequency Information ... 99
 - [Function measure] ... 349
 - Function metrics ... 360
- G**
- [General] ... 81
 - Global Pointer Table ... 308
- H**
- Hexa Converter Options ... 247
 - [Hexa Converter Options] dialog box ... 247
 - Hexadecimal Converter ... 238
 - File ... 242
 - Flow of Operation ... 238
 - Format ... 243
 - Input/Output Files ... 239
 - Operation Method ... 240
 - Other ... 246
 - Output File Formats ... 253
- I**
- Include ... 86, 107, 137
 - Individual Warnings ... 106
 - Inline Expansion ... 45
 - [Input File] ... 84
 - Input/Output Files ... 29
 - Installation ... 23
 - Intel expanded ... 253
 - Intermediate Output Directory ... 70
 - Internal ROM ... 176
- L**
- [Library] ... 172
 - Library ... 59
 - Line Number Information ... 308
 - [Link Directive] ... 73
 - Link Directive ... 189
 - Link Map ... 171, 175, 178
 - Linker ... 153
 - Device ... 164
 - Flow of Operation ... 153
 - Input File ... 159
 - Library ... 161
 - Operation Method ... 157
 - Option ... 165
 - Other ... 168
 - Output File ... 160
 - Linker Options ... 170
 - [Linker Options] dialog box ... 170
 - Loop Expansion Optimization ... 47
- M**
- Magic number ... 146
 - main function ... 199
 - Mask Register ... 103, 139, 176
 - Mathematics Library ... 173, 199
 - Memory Layout Visualization Tool ... 366
 - Input File ... 367
 - Operation Method ... 368
 - Options ... 369
 - Output Files ... 381
 - Output Information ... 367
 - Memory Map ... 235
 - [Message] ... 105
 - Message ... 415
 - Message Dialog Box ... 486
 - Message Format ... 415
 - Motorola S type ... 257
- N**
- NOBITS ... 251
- O**
- O ... 119
 - Ob ... 118
 - [Object Analysis Tool] dialog box ... 297, 317, 378
 - Od ... 118
 - Og ... 119
 - Operating Environments ... 22
 - Operation Method ... 32
 - Optimization ... 44, 91
 - [Optimization and Debug Information] ... 90
 - Optimization Level ... 81
 - [Option] ... 137, 174, 235, 249, 270, 289
 - Option Byte ... 203
 - Options ... 33
 - Os ... 120
 - Ot ... 120
 - Other ... 62
 - [Others] ... 109, 177, 237, 252, 292
 - [Output Code] ... 100
 - [Output File] ... 98
 - Output File ... 35, 171
 - [Output Index] dialog box ... 302
- P**
- Package Configuration ... 21
 - Packing of Structs ... 102
 - PM+ ... 32
 - [Preprocessor] ... 86
 - Preprocessor ... 41
 - PROGBITS Data ... 309
 - Program Header Table ... 306, 310, 408
 - Programmable Peripheral I/O Register ... 202
 - Prologue/Epilogue Runtime ... 50, 101, 200
- R**
- [RAM map] ... 373, 379
 - RAM map option ... 375
 - [RAM map option] dialog box ... 375
 - _rcopy ... 219
 - _rcopy1 ... 220
 - _rcopy2 ... 221
 - _rcopy4 ... 222
 - Register ... 49
 - Register Mode ... 101, 176
 - Register Mode Information ... 308
 - Relink function ... 181
 - Relocation Error ... 175
 - Relocation Information ... 307
 - Rescan ... 176
 - Reserved Register ... 108, 139
 - Reserved Sections ... 413
 - Reserved Symbols ... 198
 - [ROM] ... 74, 78

- ROM Area ... 250
 - [ROM Processor Options] dialog box ... 231
 - ROM Processor Options ... 231
 - ROMization ... 40, 201
 - ROMization Processor ... 204
 - Copy Functions ... 218
 - Creating Object ... 212
 - File ... 227
 - Flow of Operation ... 204
 - Input/Output Files ... 207
 - Operation Method ... 225
 - Options ... 228
 - Other ... 230
 - rompct ... 74
 - rompsec Section ... 208
- S**
- sconst ... 101
 - sdata/sbss ... 138
 - [Section] ... 233
 - Section File ... 84
 - Section File Format ... 275
 - Section File Generator ... 272
 - Operation Method ... 280
 - Options ... 284
 - Section File Generator Options ... 287
 - [Section File Generator Options] dialog box ... 287
 - Section Files ... 272
 - Section Header Table ... 306, 311, 409
 - Section Types ... 410
 - Sections ... 411
 - Security ID ... 77
 - Signed ... 53
 - Source Debugger ... 37
 - [Stack Size Unknown / Adjusted Function Lists] dialog box ... 394
 - Standard Folder ... 24
 - Standard Library ... 172
 - [Startup] ... 72
 - Startup File ... 72
 - Startup Routine ... 188
 - Static performance analyzer ... 336, 372
 - [Static performance analyzer] dialog box ... 336, 372
 - strcmp Expansio ... 48
 - strcpy ... 103
 - strcpy Expansion ... 48
 - Strict Integer Extension ... 89
 - String Table ... 307, 412
 - Structure of Object File ... 406
 - Structure Packing ... 55
 - Suppress Warning ... 175
 - switch ... 54, 102
 - Symbol Table ... 249, 307, 311, 411
- T**
- [Tag information] ... 345
 - Tag information ... 355
 - Temporary Directory ... 109
 - tidata Section ... 289
 - tidata.byte Section ... 289
- U**
- Undefine Macro ... 87
 - Uninstallation ... 26
 - Use Individual Option ... 72
- V**
- V850 core ... 199
 - V850E2 core ... 199
 - V850Ex core ... 199
 - Variable Placement ... 51
- W**
- Warning Level ... 82, 105
 - Warning Message ... 60
 - Windows version ... 22
- Z**
- Zero Register ... 108, 139

*For further information,
please contact:*

NEC Electronics Corporation
1753, Shimonumabe, Nakahara-ku,
Kawasaki, Kanagawa 211-8668,
Japan
Tel: 044-435-5111
<http://www.necel.com/>

[America]

NEC Electronics America, Inc.
2880 Scott Blvd.
Santa Clara, CA 95050-2554, U.S.A.
Tel: 408-588-6000
800-366-9782
<http://www.am.necel.com/>

[Europe]

NEC Electronics (Europe) GmbH
Arcadiastrasse 10
40472 Düsseldorf, Germany
Tel: 0211-65030
<http://www.eu.necel.com/>

Hanover Office
Podbielskistrasse 166 B
30177 Hannover
Tel: 0 511 33 40 2-0

Munich Office
Werner-Eckert-Strasse 9
81829 München
Tel: 0 89 92 10 03-0

Stuttgart Office
Industriestrasse 3
70565 Stuttgart
Tel: 0 711 99 01 0-0

United Kingdom Branch
Cygnus House, Sunrise Parkway
Linford Wood, Milton Keynes
MK14 6NP, U.K.
Tel: 01908-691-133

Succursale Française
9, rue Paul Dautier, B.P. 52
78142 Velizy-Villacoublay Cédex
France
Tel: 01-3067-5800

Sucursal en España
Juan Esplandiu, 15
28007 Madrid, Spain
Tel: 091-504-2787

Tyskland Filial
Täby Centrum
Entrance S (7th floor)
18322 Täby, Sweden
Tel: 08 638 72 00

Filiale Italiana
Via Fabio Filzi, 25/A
20124 Milano, Italy
Tel: 02-667541

Branch The Netherlands
Steijgerweg 6
5616 HS Eindhoven
The Netherlands
Tel: 040 265 40 10

[Asia & Oceania]

NEC Electronics (China) Co., Ltd
7th Floor, Quantum Plaza, No. 27 ZhiChunLu Haidian
District, Beijing 100083, P.R.China
Tel: 010-8235-1155
<http://www.cn.necel.com/>

NEC Electronics Shanghai Ltd.
Room 2511-2512, Bank of China Tower,
200 Yincheng Road Central,
Pudong New Area, Shanghai P.R. China P.C:200120
Tel: 021-5888-5400
<http://www.cn.necel.com/>

NEC Electronics Hong Kong Ltd.
Unit 1601-1613, 16/F., Tower 2, Grand Century Place,
193 Prince Edward Road West, Mongkok, Kowloon, Hong Kong
Tel: 2886-9318
<http://www.hk.necel.com/>

NEC Electronics Taiwan Ltd.
7F, No. 363 Fu Shing North Road
Taipei, Taiwan, R. O. C.
Tel: 02-8175-9600
<http://www.tw.necel.com/>

NEC Electronics Singapore Pte. Ltd.
238A Thomson Road,
#12-08 Novena Square,
Singapore 307684
Tel: 6253-8311
<http://www.sg.necel.com/>

NEC Electronics Korea Ltd.
11F., Samik Lavied'or Bldg., 720-2,
Yeoksam-Dong, Kangnam-Ku,
Seoul, 135-080, Korea
Tel: 02-558-3737
<http://www.kr.necel.com/>