

White Paper

Powering Automotive Cockpit Electronics

Introduction

The growth of automotive cockpit electronics has exploded over the past decade. Previously, self-contained systems such as steering, braking, traction, and other safety devices, along with entertainment equipment and navigation aids, have evolved into integrated infotainment systems, increasingly overlaid with advanced driver assistance systems (ADAS). The latter in particular have become the latest consumer “must-have” and a point of differentiation that’s helping car salesmen ratchet the buyer up the price ladder. And the evolution doesn’t stop here; these systems are the first stepping-stones toward driverless cars.

What differentiates these much more sophisticated systems is the processing power they employ. For example, smart forward looking cameras use DSPs to analyze their images, while infotainment head units and instrument cluster displays feature GPUs, SOCs and FPGAs to implement specific functions.

All of these processors, logic devices, memory and interface circuits demand point-of-load (POL) power at ever-lower voltages and higher currents. Figure 1 shows an electronic control unit’s typical power tree. The car battery commonly specifies a full operation range from 9V to 18V, with short transients that can exceed 40V and dip below 5V DC. The varying load needs of entry level to luxury cars require flexible solutions provided by secondary rail POL buck regulators that can deliver higher current power supply regulation at lower voltages.

There are many different ways to implement a buck regulator. In order to determine which solution delivers the performance and features needed for a given requirement, it is important for system designers to understand the architectural choices that lie behind the various IC designs. This article examines the asynchronous buck versus synchronous buck configuration. It also reviews the tradeoffs between the N-channel or P-channel transistors used for the switches in a synchronous buck configuration. A family of fully optimized 3A, 4A and 5A sync buck regulators is highlighted, and their wettable flank thin quad flat no-lead (WFQFN) package is examined.

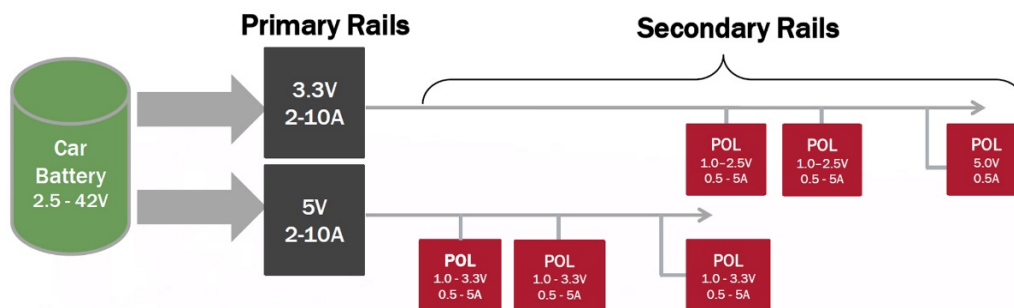

Figure 1. Typical automotive power supply architecture

The Asynchronous Buck Regulator

As can be seen in Figure 2, the asynchronous buck DC/DC converter has one switch (S1) that is driven on and off to control the duty cycle ratio. The circuit includes a diode that acts as a secondary switch when the

potential across it causes forward biasing. When switch S1 is on, the input voltage is connected to the inductor, causing current to build up in the inductor until switch S1 is shut off. When S1 is switched off, the current flowing through the switch to the inductor is interrupted.

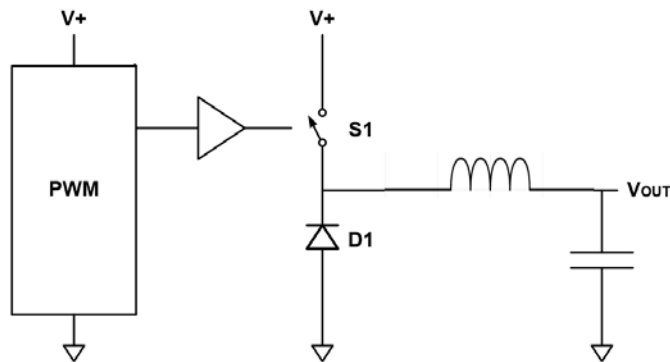

Figure 2. Asynchronous buck implementation

However, due to the nature of the inductor, the current flowing through it wants to continue flowing in the same direction. For this to happen, the voltage polarity across the inductor changes, allowing the current to flow through in the same direction. When this occurs, the diode is forward biased, allowing the pass through current. Regulation of the output voltage is performed by feedback (not shown in Figure 2) to control the duty cycle of switch S1.

The Synchronous Buck Regulator

The synchronous buck DC/DC converter is illustrated in Figure 3. In this configuration, the diode is replaced with a switch. The switch is a FET, which is designed to have very low on-resistance ($R_{DS(on)}$) that allows the FET switch to exhibit lower voltage drop when current flows through it. This results in the circuit having much higher efficiency in comparison to when a diode is used. For example, if the average current in the system is 5A, the power loss in the diode would be 0.5 volts x 5A = 2.5 watts (this assumes a Schottky diode with a forward voltage of 0.5 volts at 5A), versus 5A x 5A x 0.011 ohms = 0.275 watts with a transistor having 11 mohm of on-resistance. The transistor achieves better than a 9x reduction in power dissipation.

However, with switch-2 integrated onto the die, the S2 losses will be on the die. This will require better thermal design of the die, but the overall improvement in efficiency will result in less total heat generated. The die will require more silicon area when switch S2 and its drive circuitry are included, but this will reduce the board area and component count since the external diode is no longer required.

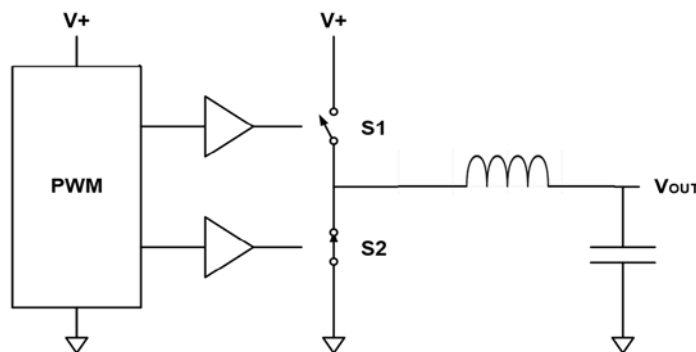

Figure 3. Synchronous buck implementation

There is another benefit to the synchronous circuit over the asynchronous circuit that is not obvious to many engineers. When the output load is very low, the inductor current may become discontinuous, meaning the current falls to zero. In the asynchronous configuration, the discontinuous current can result in electromagnetic interference (EMI) emissions. A minimum load may be required for the asynchronous circuit to prevent discontinuous current operation. The synchronous configuration can be designed to enable switch S2 to be turned on under light load conditions. This will allow negative inductor current to flow. While this decreases efficiency at light loads, it allows continuous current flow and prevents EMI.

Therefore, the buck regulator, implemented as a synchronous buck, can provide higher efficiency and lower EMI while occupying less board space than the asynchronous version using a diode. The synchronous buck provides even more benefits if its implementation is optimized for the specific voltage regulation applications.

A circuit implementation of the synchronous buck would use FET transistors for the upper and lower switches. The lower FET is always an N-channel FET. N-channel devices offer higher electron mobility, and therefore lower resistance for a given size. Nevertheless, the upper FET in a synchronous buck converter can be implemented as either an N-channel or a P-channel. Each has its own advantages and disadvantages.

N-Channel vs. P-Channel High-Side FET Switch

To examine why employing buck regulators using a P-channel device as the upper FET can be better in some applications, it is necessary to look at the switching section of a synchronous converter with an upper N-channel FET as shown in Figure 4.

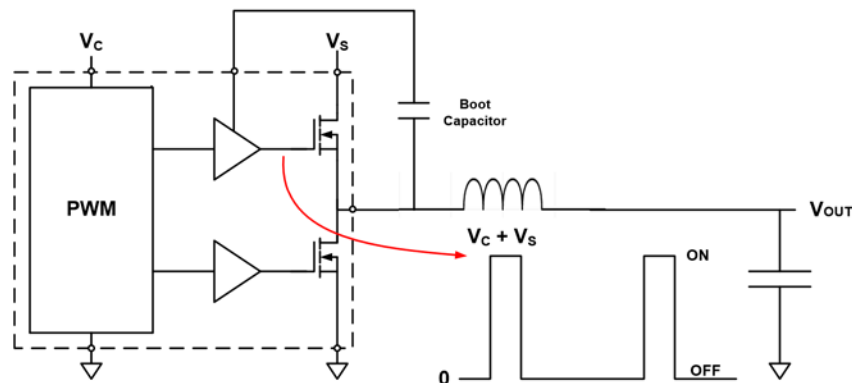

Figure 4. Synchronous buck with N-channel high-side FET switch

When an N-channel FET is used for the upper switch, there must be a voltage supply source greater than the voltage supplying the drain of the upper switch. For the N-channel FET to turn on with its source voltage at V_s , its gate voltage must be several volts higher than V_s . This higher voltage is typically generated by using a boot capacitor. When the lower FET is on and the upper FET is off, the boot capacitor is charged by the V_c supply. Note that V_s and V_c may be equal or different in the buck converter that uses an N-channel FET for the upper switch. If V_s is higher than V_c , the IC will need to include a level shifter to level shift the PWM signal up to the drive stage that operates at the higher V_c and boot voltage level.

When the lower FET turns off and upper FET turns on, the bottom side of the boot capacitor increases to the V_s voltage on the inductor's input. When this occurs, the top side of the boot capacitor has an approximate voltage of $V_s + V_c$ relative to ground. The upper FET's gate and the voltage swing on the boot capacitor's top side both swing from ground at their lowest potential to $V_s + V_c$ when the upper FET is switched on.

Table 1. Upper high-side FET N-channel advantages vs. disadvantages

Advantages	Disadvantages
Lower R_{DSon} for given FET size, enables lower losses with high current	Operates from higher supply voltage, requires larger IC process geometry/die size, adds cost
	Needs boot capacitor, no 100% duty ratio
	Larger voltage swings, longer switching times and higher potential for EMI

In some applications, it's better to use a synchronous buck converter like the one shown in Figure 5. It uses a P-channel FET as the upper switch. In this circuit, the gate of the upper FET needs only to switch between ground when the upper FET is on, and V_c when the upper FET is off. There is no need for a boot capacitor and the entire circuit can operate at the V_c supply voltage potential.

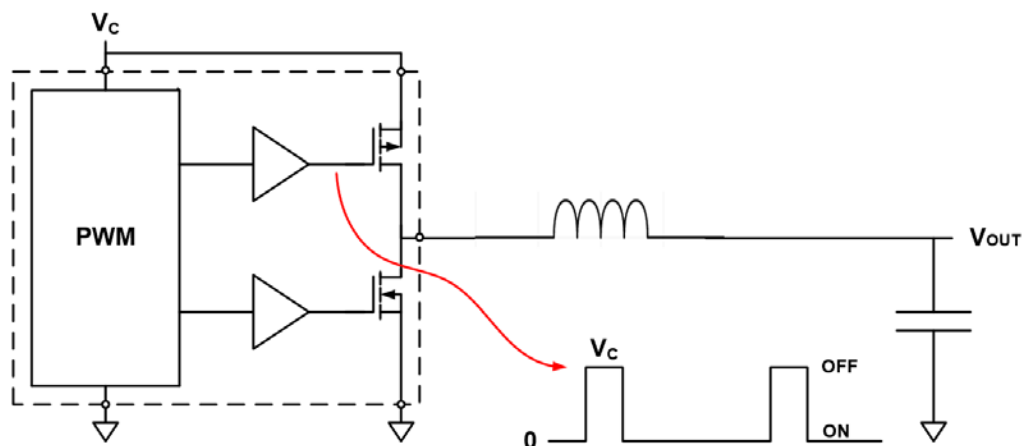

Figure 5. Synchronous buck with P-channel high-side FET switch

Table 2. Upper high-side P-channel FET advantages vs. disadvantages

Advantages	Disadvantages
Operates from lower voltage supplies, and smaller geometry silicon process results in smaller transistors	Requires larger FET to achieve same R_{DSon} as N-channel, results in higher cost for FET area
Lower voltage swings enable faster switching, lower voltage signals make EMI less likely	
Operates at higher frequency above AM radio band	
Operates at 100% duty ratio, and no boot capacitor lowers cost/saves board space	

Automotive-Grade Buck Regulator Family

The ISL78233, ISL78234 and ISL78235 pin compatible devices use the P-channel configuration. They integrate a low on-resistance P-channel (35mΩ, typical) high-side FET and N-channel (11mΩ, typical) low-side FET to maximize efficiency. At 100% duty cycle operation, there is less than 250mV drop across the P-channel FET at 5A output current. Most of the time, the devices will be converting 5 volts down to a voltage as low as 0.6 volts, and the duty ratio will be below 50%. Therefore, even though the P-channel FET has higher resistance than the N-channel FET, the P-channel will be switched on for much less time, and will have less impact on efficiency.

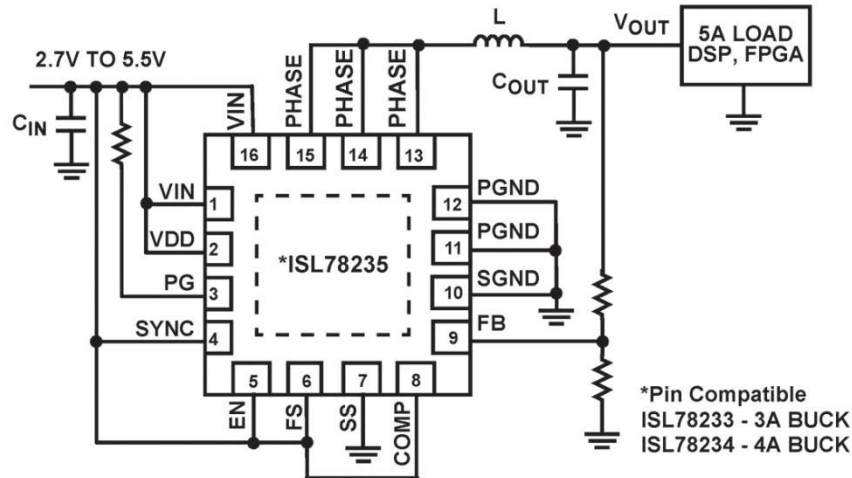

Figure 6. Typical application for ISL78235 5A sync buck regulator

The ISL7823x devices shown in Figure 6 are designed to operate from lower input voltages (5.5V down to 2.7V). As a result, most of their transistors use a smaller geometry, take up less die area and can switch at higher speeds. And since the gate of the upper P-channel FET is driven with the same supply, the signal swing is lower than if an N-channel arrangement is used. This also enables faster switching. The devices can operate with a clock as high as 4MHz, and when set to switch at 2MHz, they can achieve a guaranteed minimum on time of only 100ns. Since 2MHz has a period of 500ns, the devices can down convert with a guaranteed 20% minimum duty ratio. This enables the regulators to output a wide range of voltages while operating at a high frequency.

A 100% duty ratio is possible because no time is required to charge a boot capacitor (the ISL7823x devices do not use one). Moreover, no boot capacitor equates to no radiated fields. The high 2MHz switching frequency also enables the use of a smaller power inductor and lower valued capacitors on the regulator's input and output. It's also above the AM radio band and helps prevent EMI at these frequencies.

Wettable Flank Package Allows Optical Inspections

The ISL7823x devices are available in 5mm x 5mm 16-lead WFQFN packages with an exposed pad for improved thermal performance. Because they offer 3A, 4A or 5A output current options, it's easy to upgrade a design just by dropping in a new IC with no change in the PCB layout. This saves development costs and time. In addition, the WFQFN shown in Figure 7 permits verification of automotive manufacturing quality by allowing optical inspections to verify proper soldering joints.

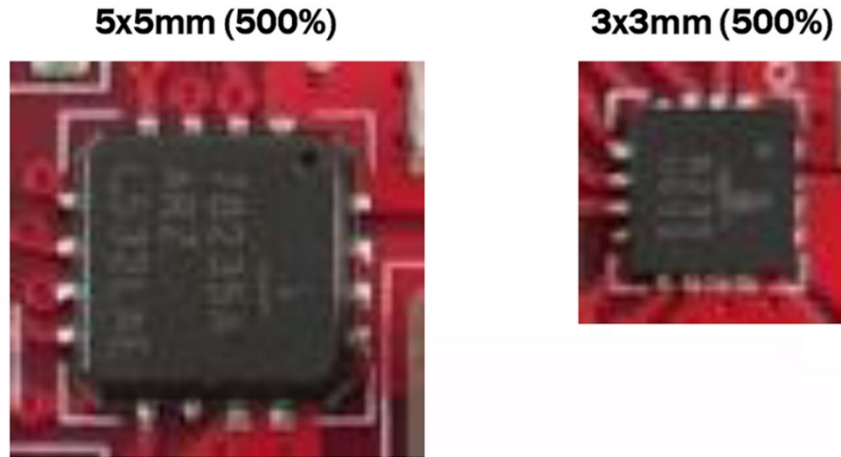

Figure 7. Magnification shows more prominent solder joints on the ISL78235 5x5mm WFQFN, compared with the QFN version

Conclusion

The evolution of automotive cockpit electronics into highly integrated driver assistance systems provides today's drivers with more safety, comfort, and infotainment features than ever imagined. This is placing new demands on secondary rail power supplies. The varying loads require flexible solutions that can deliver higher current power supply regulation at lower voltages. System designers also want to be able to use the same POL devices across a range of vehicle designs, from entry level to luxury cars.

This goal is met with a synchronous buck regulator design that uses high-side P-channel MOSFETs and other architectural enhancements to deliver an optimized secondary power rail solution. As vehicle manufacturers continue to innovate, they need to be able to rely on semiconductor suppliers to deliver the flexible, rugged and higher performance ICs that help them realize their system design goals.

Next Steps

- [Learn more about the ISL78233/34/35](#)
- [Get the datasheet](#)
- [Simulate an ISL78235](#)

#

About Renesas Electronics Corporation

Renesas Electronics Corporation delivers trusted embedded design innovation with complete semiconductor solutions that enable billions of connected, intelligent devices to enhance the way people work and live—securely and safely. A global leader in microcontrollers, analog, power, and SoC products, Renesas provides the expertise, quality, and comprehensive solutions for a broad range of Automotive, Industrial, Home Electronics, Office Automation and Information Communication Technology applications to help shape a limitless future. Learn more at [renesas.com](https://www.renesas.com)

+1 408-432-8888 | © Renesas Electronics America. All rights reserved. Renesas (and design) are trademarks owned by Renesas Electronics Corporation or one of its subsidiaries. All other trademarks mentioned are the property of their respective owners.