

Introduction

Levitorator is a device used to make an object float in space by means of a dynamic equilibrium between gravity and the magnetic force simultaneously acting on the object. It is to be noted that only the dynamic magnetic field and electronics (acting as the feedback) make such a control possible. Unfortunately, static magnetic fields cannot be used in such systems, since the object will be in a state of unstable equilibrium that will invariably lead to its downfall.

This app note demonstrates how the GreenPAK is used as a linear system regulating element with the feedback.

Levitorator Design Analysis

Consider the system performance using the block circuit as an example (see Figure 1). When the permanent magnet approaches the Hall sensor (SS495 type), its output voltage increases linearly with the magnetic field strength. In the initial state, when there is no magnetic field, the sensor output voltage is half of the supply voltage (please see datasheet for SS495 sensor).

The signal of the instantaneous value of the magnetic field strength, created by a permanent magnet, enters the PWM signal regulation and generation circuit, which, in turn, controls the solenoid coil. In such a way, feedback appears and the solenoid coil creates a magnetic field, which keeps the permanent magnet in equilibrium with the force of gravity.

The simplified control process is as follows:

1. Magnet is absent - signal from the sensor is maximal - control unit sets the maximal duration of the PWM signal (~ 100%), maximal current flows through the solenoid coil and the solenoid magnetic field strength is at the maximum level.
2. Magnet approaches the sensor - the magnetic field strength of the permanent magnet increases and the input signal of the control unit decreases. Respectively, the PWM signal duration and the solenoid coil current decreases. Consequently, the solenoid magnetic field, which attracted permanent magnet, decreases as well.
3. At the maximal application of the permanent magnet to the sensor - the PWM signal duration is minimal; current hardly flows through the solenoid coil and its magnetic field is almost absent - only gravity acts on the permanent magnet and it falls down.

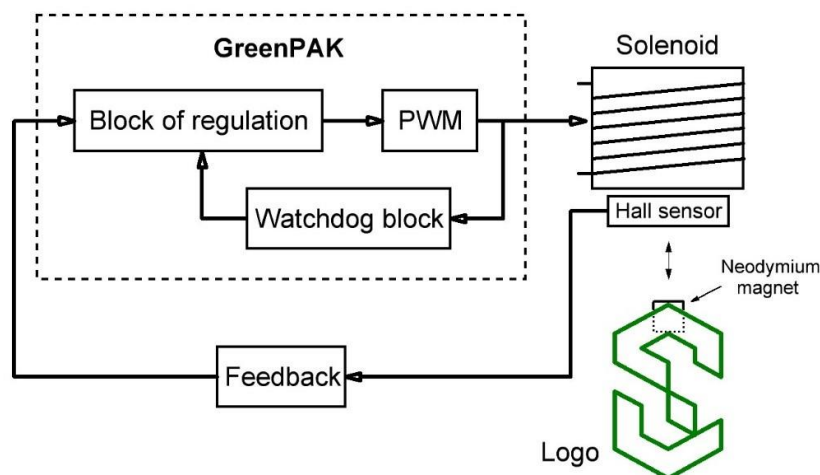

Figure 1. Block circuit of Levitorator system

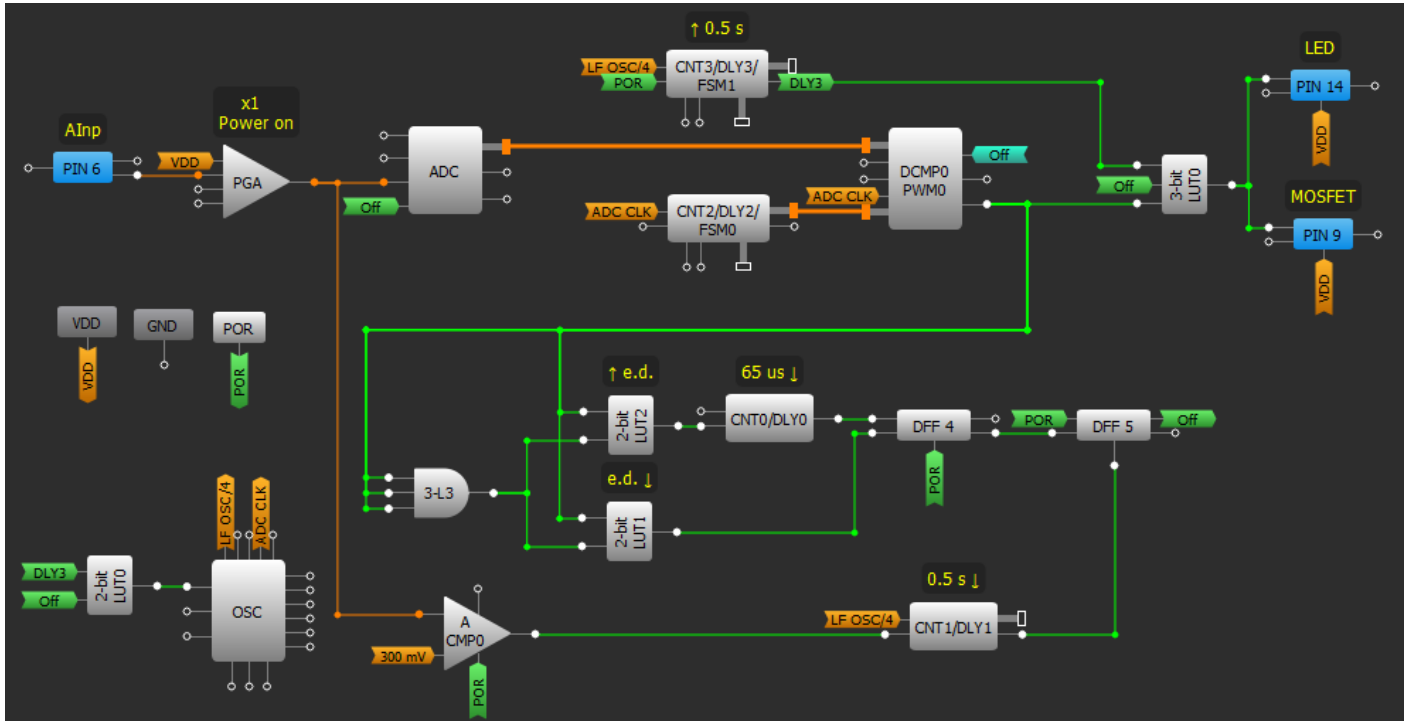

Figure 2. GreenPAK designer schematic view

The process is repeated and the permanent magnet is not falling down (it is also not being attracted) – it falls down and attracts several thousand times per second, i.e. there is a dynamic equilibrium between the gravity force and the magnetic adhesion - permanent magnet hangs in the air (see Figure 3).

It can be observed that this control method has a drawback; when the permanent magnet is absent (i.e. the levitation object is absent). In this case, current that flows through the solenoid coil is maximal (the system tries to attract the currently absent permanent magnet by increasing the field to the maximum possible).

The best solution in this situation is to turn the solenoid coil off. This function is performed by the Watchdog block, built on elements such as 3-bit LUT3, 2-bit LUT2, 2-bit LUT1, DLY0, DFF4 and DFF5 (See appendix 1).

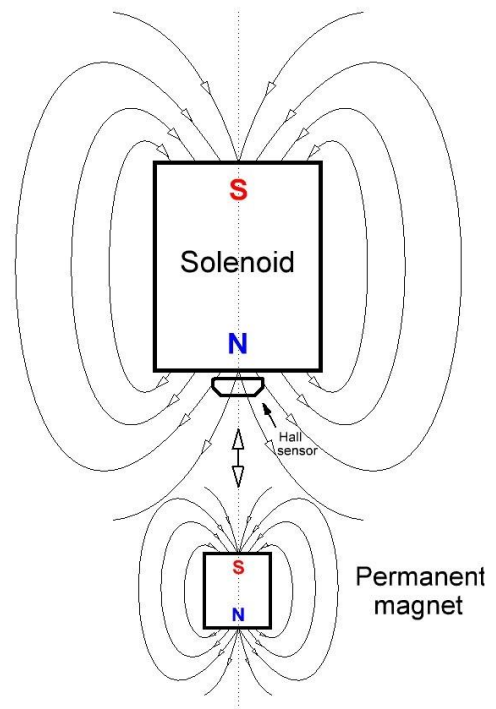

Figure 3. Magnetic field geometry scheme

This unit constantly monitors the PWM generator output signal duration (DCMP0/PWM0) and if it exceeds a specified duration (DLY0), which corresponds to the situation when the magnet is missing (and the Hall sensor signal is maximal), the DFF5 switches to the HIGH level and turns the whole system off. The system will be turned on only if a magnet is held up close to the sensor. The ACMP0 comparator monitors the sensor signal voltage level and when it decreases below the ACMP0 Vref threshold and does not increase over 0.5 seconds (time DLY1) (i.e. a magnet is held near the sensor for at least half a second), the DFF5 will be reset and the whole system will be activated (see Figure 4, a). Besides, when the system powers up, first it is blocked for 0.5 seconds (DLY3) in order to prevent false operation during the turn-on period. The PWM generator is composed of the classical scheme and consists of the ADC, DCMP0 digital comparator and CNT2 counter.

- Channel 1 (yellow/top line) – PIN#1 (VDD)
- Channel 2 (light blue/2nd line) – PIN#6 (AInp)
- Channel 3 (magenta/3rd line) – PIN#9 (MOSFET)

Levigator Circuit Analysis

The electrical circuit of the device is presented in Appendix 2. Power supply voltage of the entire system is 12 volts. The system uses the 78L05 linear regulator, which reduces the voltage to a stable 5 volts, to power the Hall sensor and GreenPAK chip. Power control of the solenoid coil is produced through the power N-channel MOSFET, LR120N transistor. The protective diode must be connected in parallel to the solenoid coil. The protective diode protects the transistor from excess voltage (when the solenoid is switched off) through self-induction.



a)

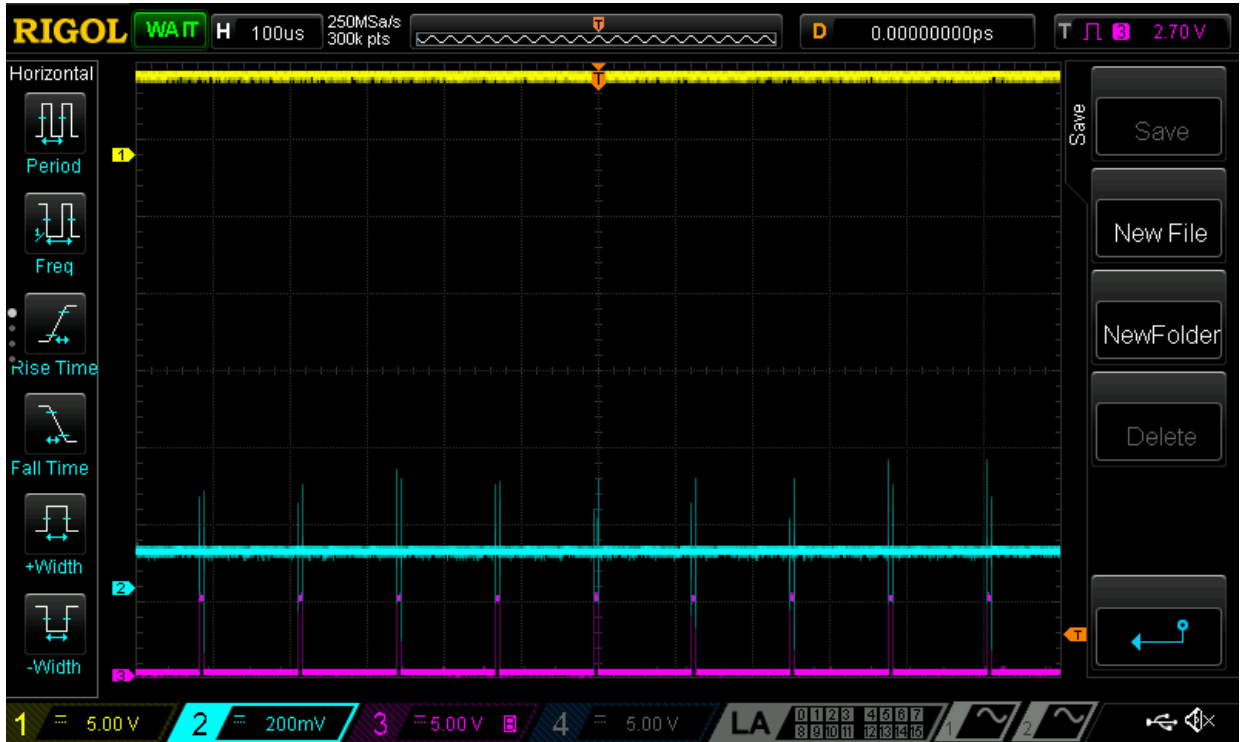

b) PWM signal is minimum

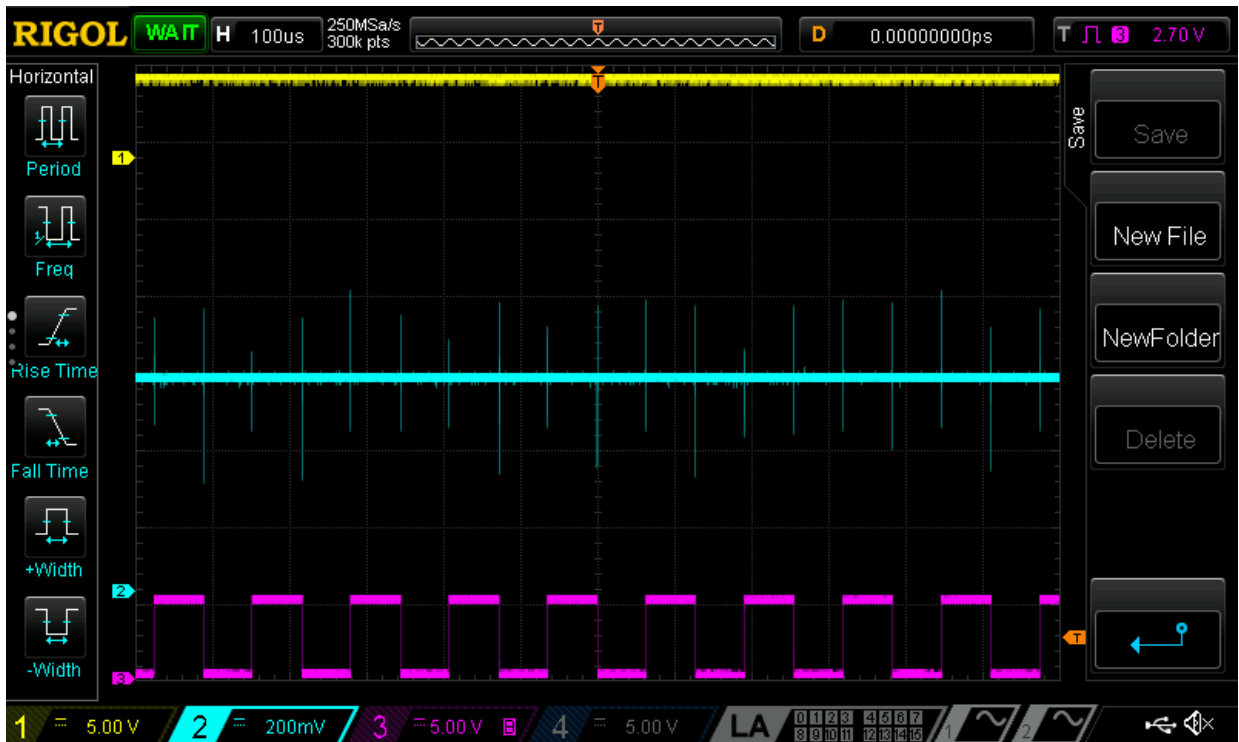

c) PWM signal is maximum

Figure 4. Example, system operates for 10 s

The C7, R3 and R4 elements are the peculiar features of this circuit, which allow the achievement of full stability of the levitating object. The lower frequency component of the Hall signal passes through the R3 R4 voltage divider and is attenuated ~ 2.2 times, so the ADC input signal could be within acceptable limits. The full signal component passes through the C7, R3 and R4 filter almost without getting attenuated. But what kind of component is this signal component and where does it come from? The low frequency component of the signal depends on the position of the magnet towards the sensor, i.e. the distance between them.



Figure 4. The demo for use

The full signal component results from the magnet fluctuations around the equilibrium point, i.e. due to changes in the position of the magnet in time (speed). The magnet velocity should be equal to 0, that is, it should be fixed.

Thus, the control signal consists of two components: a lower frequency component responsible for the position of the magnet and full signal one, for its stability.

LED1 - LED3 are indicators that report:

- the presence of 12V voltage (LED1);
- the presence of 5V voltage (LED2);
- the current state of the power transistor control (LED3).

The solenoid coil shown is custom made using copper wire (0.8 mm thickness). When the control unit sets the maximum PWM signal duration ($\sim 100\%$), the maximum current of 0.5A flows through the solenoid coil.

This corresponds to 6 watts of power, when supplied with 12 V. Such a high current is due to the fact that our levitating object has a mass of 15 to 20 grams and requires a relatively large magnetic field to be levitated. However, there is a drawback - the solenoid coil may get hot during extended operation. In other words, it is necessary to do a trade-off; the heavier the object is, the greater the magnetic field (and current) is needed for its levitating and vice versa.

Conclusion

GreenPAK contains a large number of functional elements to implement various circuit solutions that significantly reduce the number of external circuit elements. Hence, it is an ideal solution for the development of different kinds of control systems with feedback, as shown by this example of a levitator device. Low power consumption and small chip size are other benefits of GreenPAK.

Appendix 1

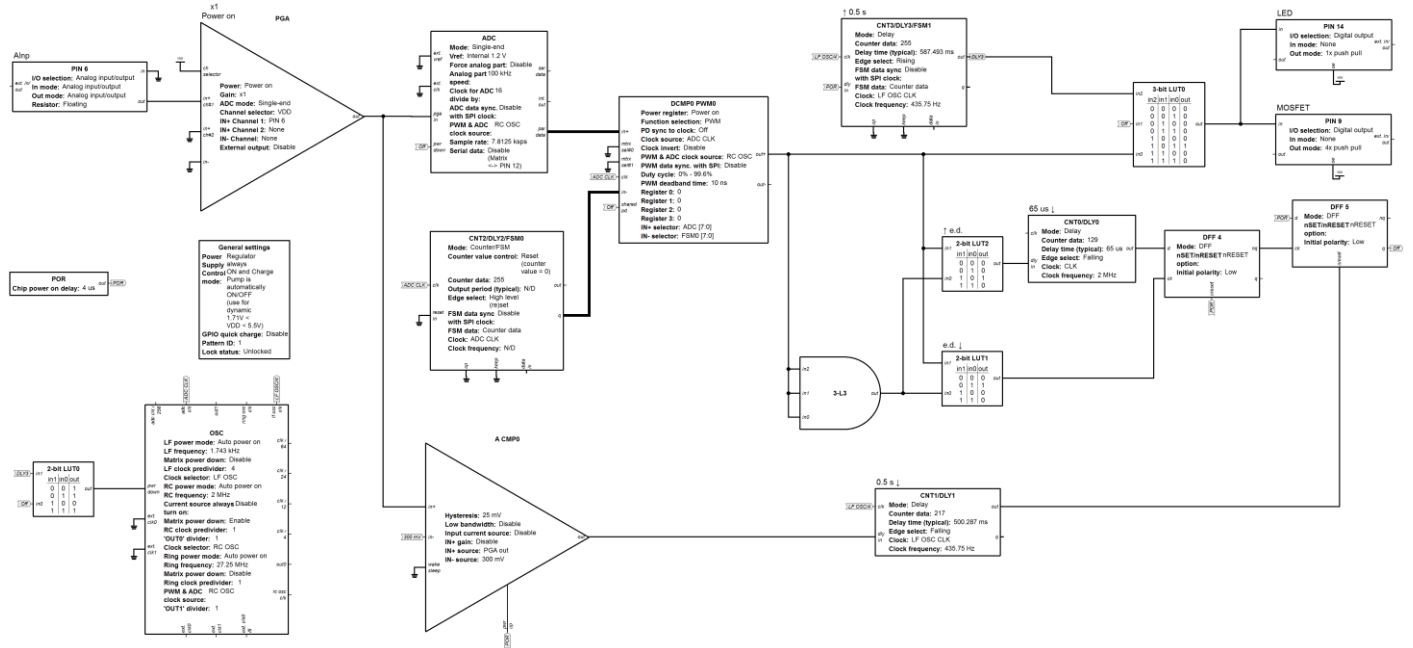

Block Diagram for Design

Appendix 2

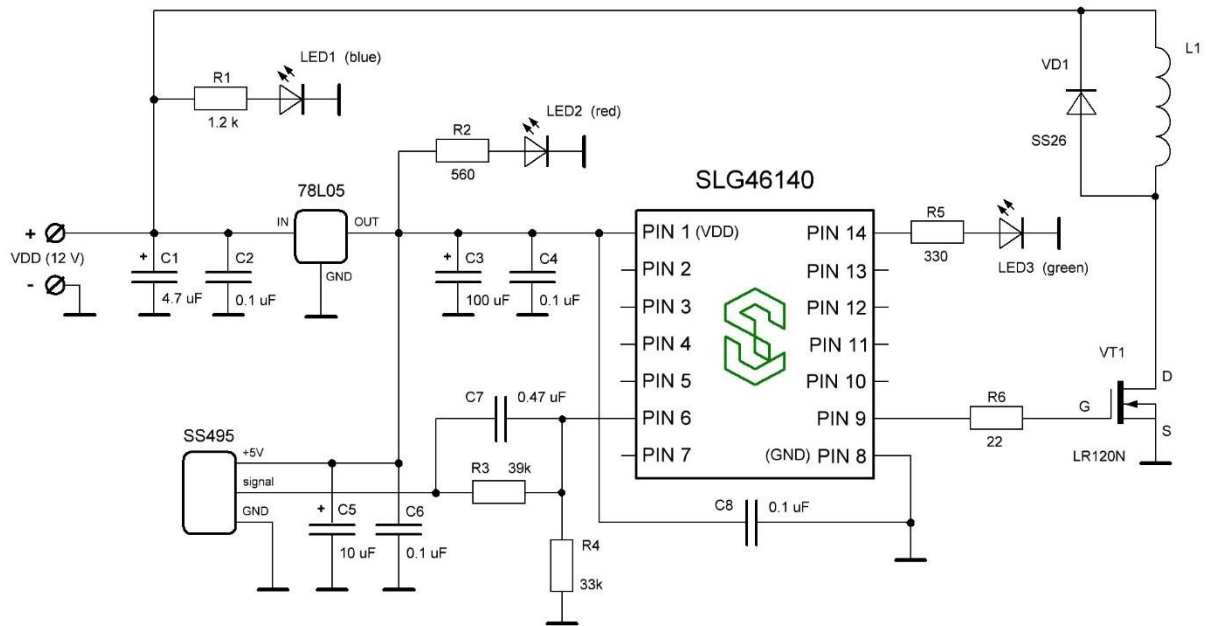

Electrical circuit of Levigator system

IMPORTANT NOTICE AND DISCLAIMER

RENESAS ELECTRONICS CORPORATION AND ITS SUBSIDIARIES (“RENESAS”) PROVIDES TECHNICAL SPECIFICATIONS AND RELIABILITY DATA (INCLUDING DATASHEETS), DESIGN RESOURCES (INCLUDING REFERENCE DESIGNS), APPLICATION OR OTHER DESIGN ADVICE, WEB TOOLS, SAFETY INFORMATION, AND OTHER RESOURCES “AS IS” AND WITH ALL FAULTS, AND DISCLAIMS ALL WARRANTIES, EXPRESS OR IMPLIED, INCLUDING, WITHOUT LIMITATION, ANY IMPLIED WARRANTIES OF MERCHANTABILITY, FITNESS FOR A PARTICULAR PURPOSE, OR NON-INFRINGEMENT OF THIRD-PARTY INTELLECTUAL PROPERTY RIGHTS.

These resources are intended for developers who are designing with Renesas products. You are solely responsible for (1) selecting the appropriate products for your application, (2) designing, validating, and testing your application, and (3) ensuring your application meets applicable standards, and any other safety, security, or other requirements. These resources are subject to change without notice. Renesas grants you permission to use these resources only to develop an application that uses Renesas products. Other reproduction or use of these resources is strictly prohibited. No license is granted to any other Renesas intellectual property or to any third-party intellectual property. Renesas disclaims responsibility for, and you will fully indemnify Renesas and its representatives against, any claims, damages, costs, losses, or liabilities arising from your use of these resources. Renesas' products are provided only subject to Renesas' Terms and Conditions of Sale or other applicable terms agreed to in writing. No use of any Renesas resources expands or otherwise alters any applicable warranties or warranty disclaimers for these products.

(Disclaimer Rev.1.01)

Corporate Headquarters

TOYOSU FORESIA, 3-2-24 Toyosu,
Koto-ku, Tokyo 135-0061, Japan
www.renesas.com

Trademarks

Renesas and the Renesas logo are trademarks of Renesas Electronics Corporation. All trademarks and registered trademarks are the property of their respective owners.

Contact Information

For further information on a product, technology, the most up-to-date version of a document, or your nearest sales office, please visit www.renesas.com/contact-us/.