

Lead Forming and Taping

Taping

Radial taping standard packaging specifications

Radial taping standard zigzag box packaging specifications

| | |
|-------------|-------------------|
| Designation | Product name + TZ |
|-------------|-------------------|

Dimensions and External View

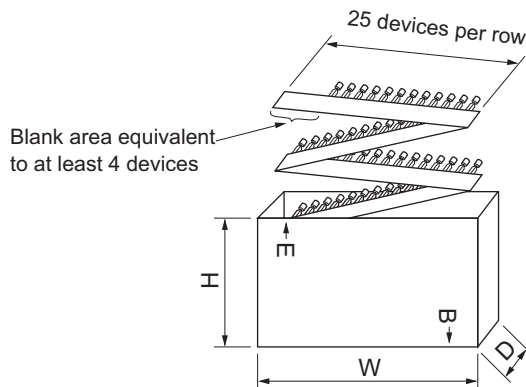

| Product package | Quantity | |
|-------------------|------------|----------------|
| TO-92 TO-92MOD | Zigzag box | 2,500 per reel |
| SPAK | Zigzag box | 2,500 per reel |

TO-92 (Reel capacity: 2,000 devices)

Product name indication

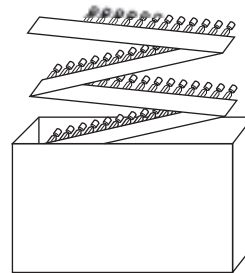
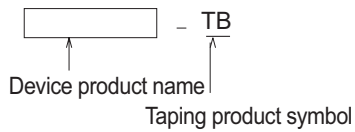

Lead Forming and Taping

Applies to packaging with the marking side uppermost, and the CMPAK center pin on the right facing the direction in which the tape is pulled.

CMPAK standard taping packaging specifications (JEITA standard RC-1009A compliant)

| | | |
|-------------|-------------------------|-----------------|
| Designation | Product name+ Mark + TR | 3,000 per reel |
| | Product name+ Mark + UR | 12,000 per reel |

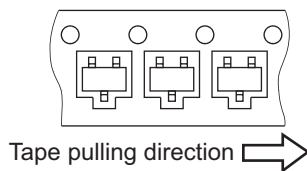

| | | |
|-------------|-------------------------|-----------------|
| Designation | Product name+ Mark + TL | 3,000 per reel |
| | Product name+ Mark + UL | 12,000 per reel |

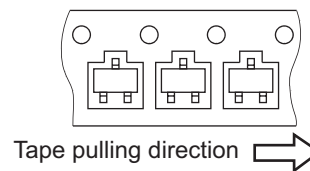

SMPAK standard taping packaging specifications (JEITA standard RC-1009A compliant)

| | | |
|-------------|-------------------------|----------------|
| Designation | Product name+ Mark + TR | 3,000 per reel |
|-------------|-------------------------|----------------|

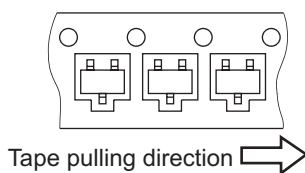

| | | |
|-------------|-------------------------|----------------|
| Designation | Product name+ Mark + TL | 3,000 per reel |
|-------------|-------------------------|----------------|

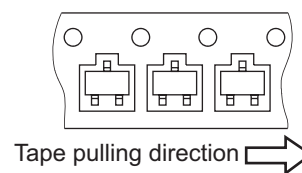

MPAK taping packaging specifications (JEITA standard RC-1009A compliant)

| | | |
|-------------|-------------------------|-----------------|
| Designation | Product name+ Mark + TR | 3,000 per reel |
| | Product name+ Mark + UR | 12,000 per reel |

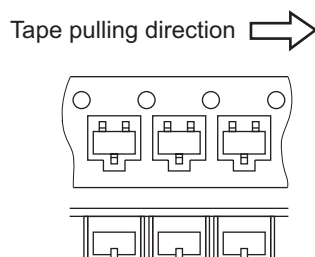

| | | |
|-------------|-------------------------|-----------------|
| Designation | Product name+ Mark + TL | 3,000 per reel |
| | Product name+ Mark + UL | 12,000 per reel |

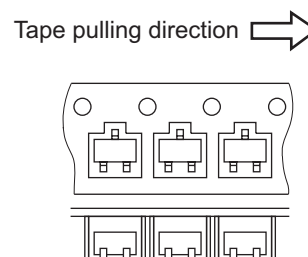

Lead Forming and Taping

Taping

SC-59 (Reel capacity: 3,000 devices)

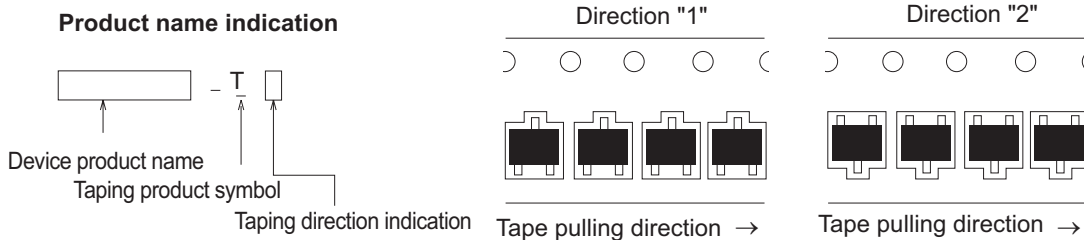

UPAK taping packaging specifications (JEITA standard RC-1009A compliant)

| | | |
|-------------|--------------------------|----------------|
| Designation | Product name + Mark + TR | 1,000 per reel |
| | Product name + Mark + UR | 4,000 per reel |

| | | |
|-------------|--------------------------|----------------|
| Designation | Product name + Mark + TL | 1,000 per reel |
| | Product name + Mark + UL | 4,000 per reel |

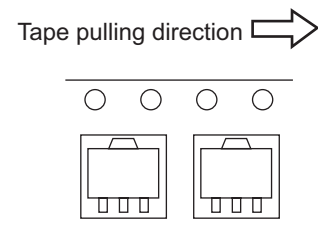
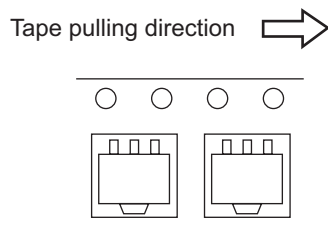

SOT-89 (Reel capacity: 3,000 devices/1,000 devices)

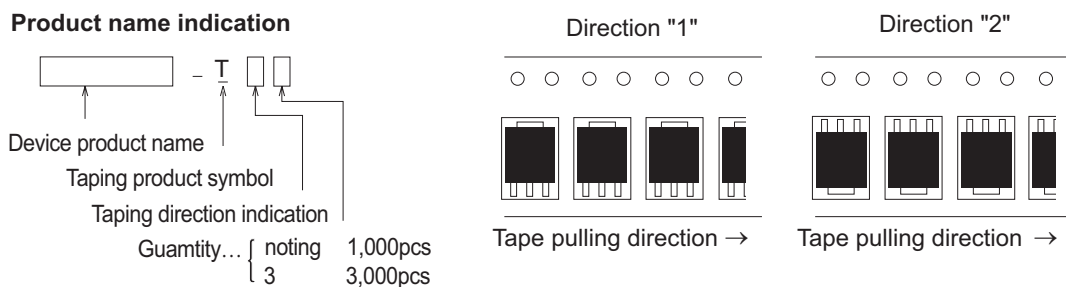

TSOP-6 taping packaging specifications

| | | |
|-------------|-------------------|----------------|
| Designation | Product name + EL | 3,000 per reel |
|-------------|-------------------|----------------|

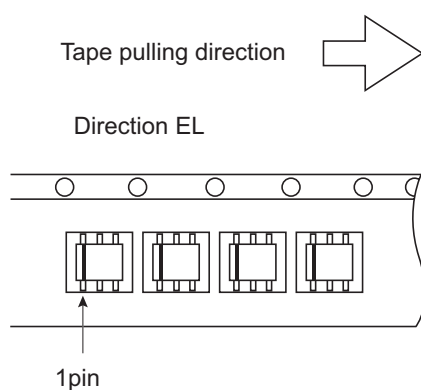

TSSOP-taping packaging specifications (JIS standard C0806 compliant)

| | | |
|-------------|-------------------|----------------|
| Designation | Product name + EL | 3,000 per reel |
|-------------|-------------------|----------------|

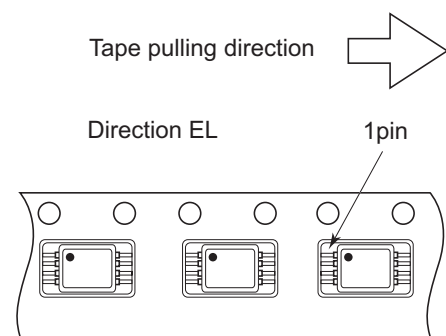

Lead Forming and Taping

TSSOP-8 (Reel capacity: 3,000 devices)

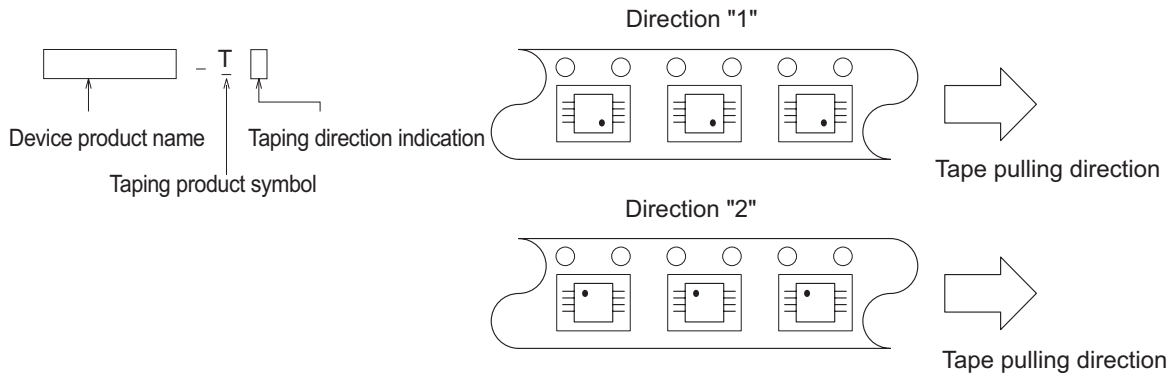

SOP-taping packaging specifications (JIS standard C0806 compliant)

| | | |
|-------------|-------------------|----------------|
| Designation | Product name + EL | 2,500 per reel |
|-------------|-------------------|----------------|

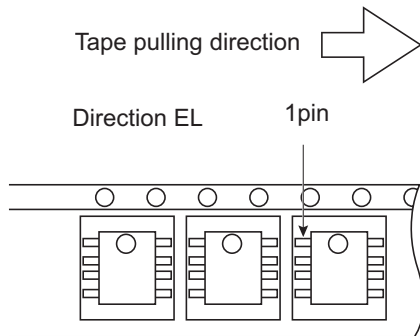

SOP-8 (Reel capacity: 3,000 devices)

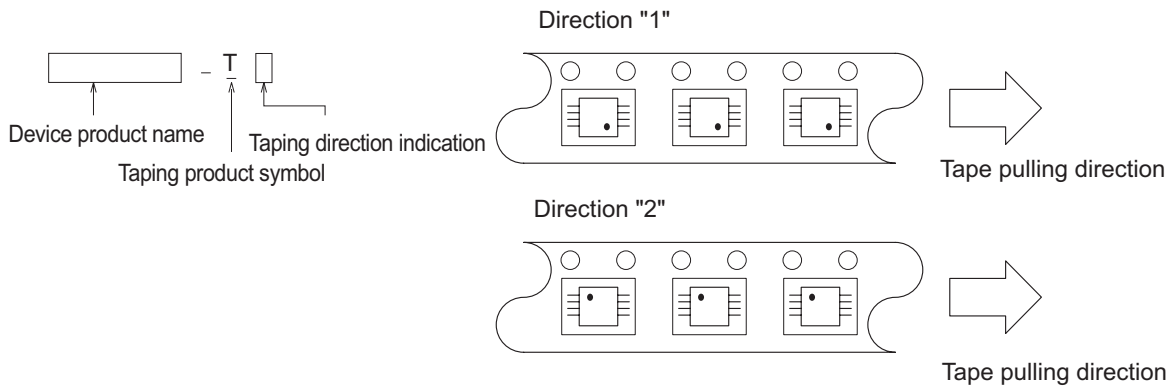

Lead Forming and Taping

Taping

Applies to packaging with the marking side uppermost, and the DPAK radiation fin on the right facing the direction in which the tape is pulled.

DPAK taping packaging specifications (JEITA standard RC-1009B compliant)

| | | |
|-------------|-------------------|----------------|
| Designation | Product name + TR | 3,000 per reel |
|-------------|-------------------|----------------|

Tape pulling direction →

Direction TR

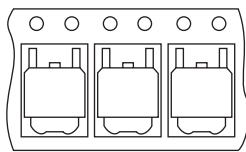

| | | |
|-------------|-------------------|----------------|
| Designation | Product name + TL | 3,000 per reel |
|-------------|-------------------|----------------|

Tape pulling direction →

Direction TL

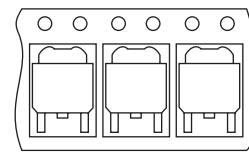

MP-3 (Reel capacity: 3,000 devices)

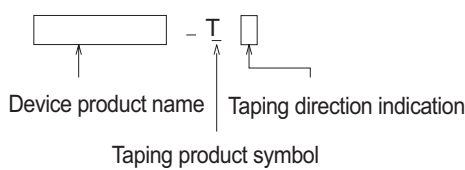

Direction "1"

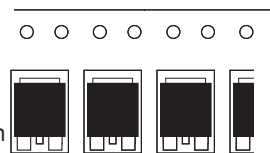

Tape pulling direction →

Direction "2"

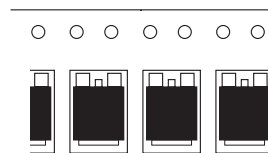

Tape pulling direction →

LPAK taping packaging specifications (JEITA standard RC-1009B compliant)

| | | |
|-------------|-------------------|----------------|
| Designation | Product name + TR | 1,000 per reel |
|-------------|-------------------|----------------|

Tape pulling direction →

Direction TR

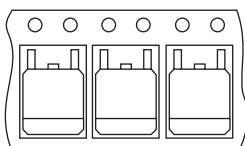

| | | |
|-------------|-------------------|----------------|
| Designation | Product name + TL | 1,000 per reel |
|-------------|-------------------|----------------|

Tape pulling direction →

Direction TL

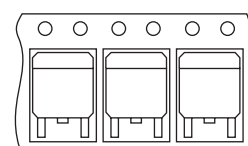

Lead Forming and Taping

TO-220S (Reel capacity: 1,000 devices)

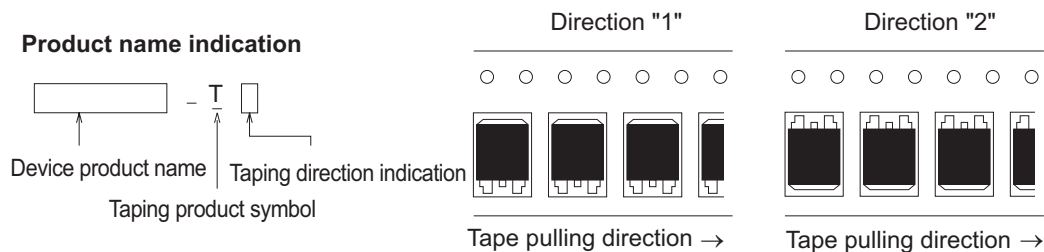

LFAK taping packaging specifications

| | | |
|-------------|-------------------|----------------|
| Designation | Product name + EL | 2,500 per reel |
|-------------|-------------------|----------------|

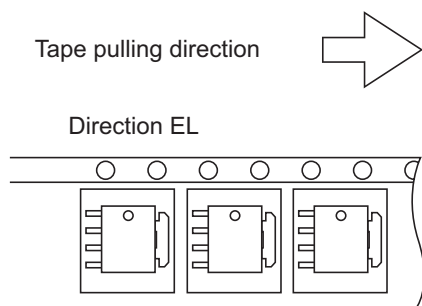

HSOP-11 taping packaging specifications

| | | |
|-------------|-------------------|----------------|
| Designation | Product name + EL | 2,500 per reel |
|-------------|-------------------|----------------|

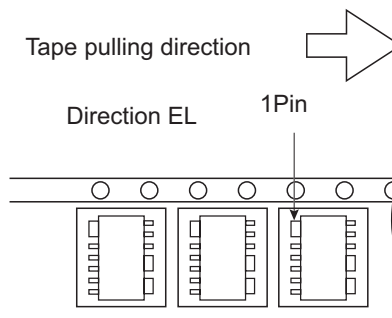

CMPAK-6 taping packaging specifications

| | | |
|-------------|-------------------|----------------|
| Designation | Product name + TL | 3,000 per reel |
|-------------|-------------------|----------------|

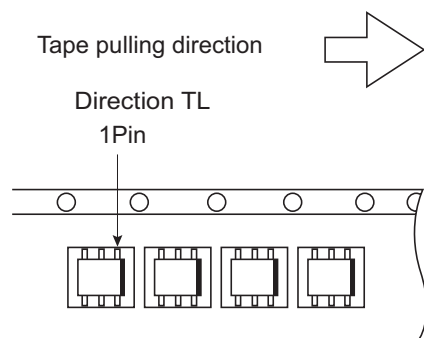

CMFPAK-6 taping packaging specifications

| | | |
|-------------|-------------------|----------------|
| Designation | Product name + EL | 3,000 per reel |
|-------------|-------------------|----------------|

